

ASSEMBLY INSTRUCTION

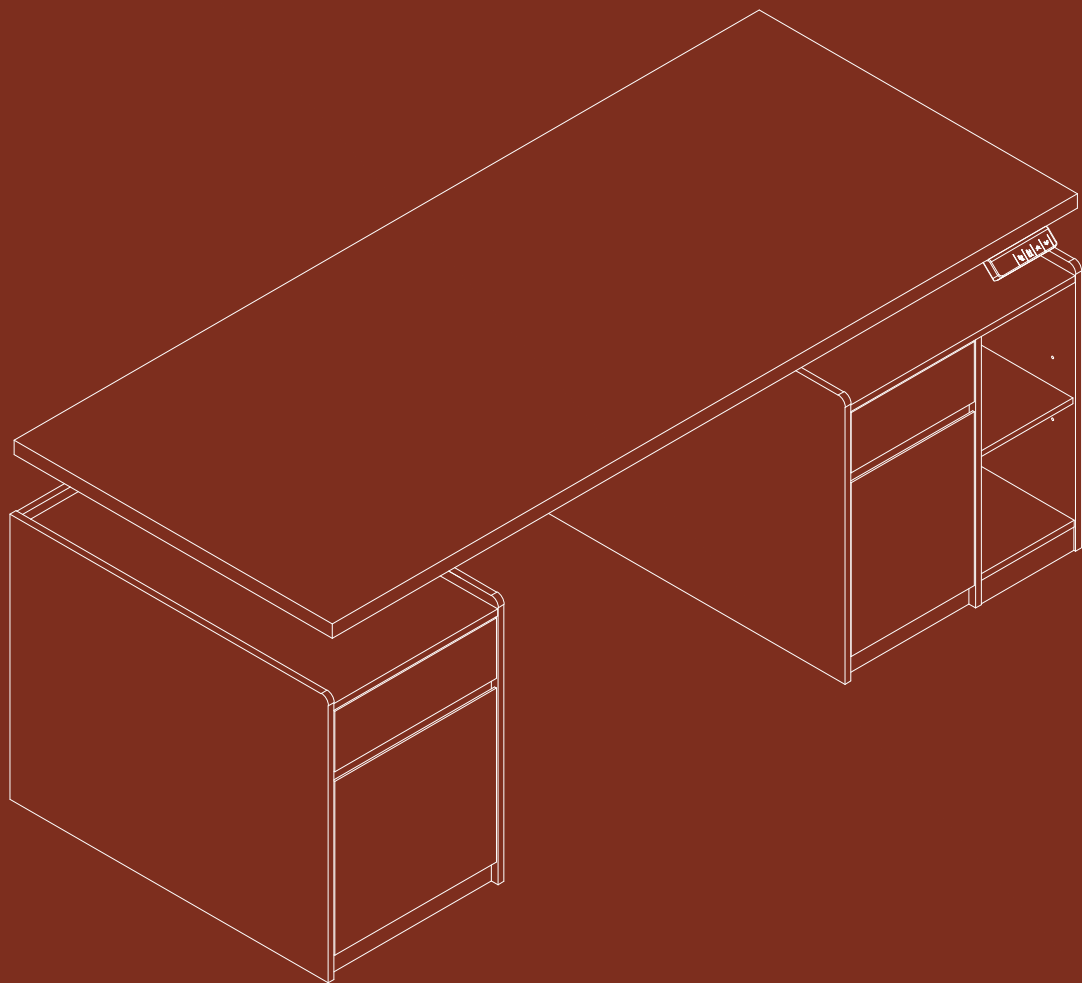

Standing Desk



INTRODUCTION



Thank you for purchasing our products. Please read the instructions carefully before installation and keep it in a safe place for future reference. If you need any assistance or support, please feel free to contact our customer support team.

PRECAUTIONS

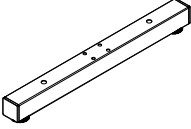
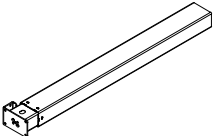
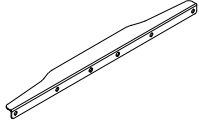
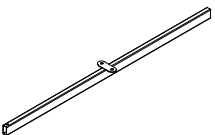
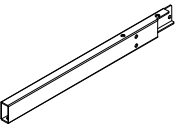
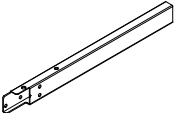
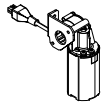
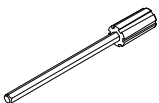
1. There are many components and accessories in the package. Each component and accessory is labeled with a letter or a number, check carefully before using any of them. Keep them away from children to prevent accidents.
 2. Please install the product on a clean and soft underlay (such as carpet or cardboard) to avoid scratching or damaging the surface of the product.
 3. The main components of the product is relatively heavy. Please pay attention to safety during installation.
 4. The product is not stable during installation. Please do not move it randomly before it is completely installed.
 5. If you have any questions during installation, please contact the customer service in time.
- * Please be sure to follow the installation steps in the manual to avoid unnecessary losses caused by improper installation.
 - * If you need further assistance, please contact the customer service online.

Parts List

ID	Parts	QTY
1		2
2		2
3		2
4		1
5		1
6		1
7		1
8		1
9		1
10		1

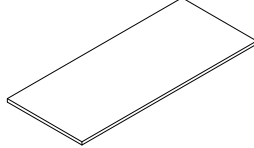
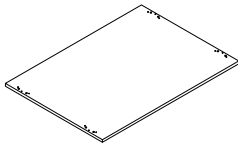
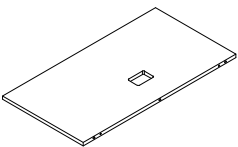
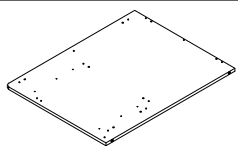
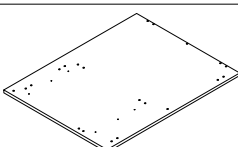
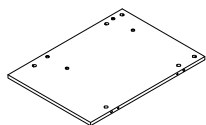
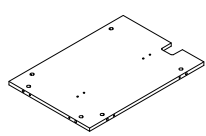
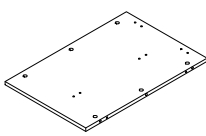
ID	Parts	QTY
11		1
12		4
13		1
14		1
15		1
16		1
17		1
18		1
19		1
20		1

Hardware List

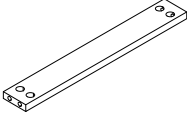
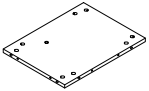
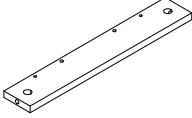
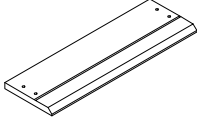
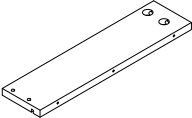
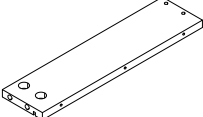
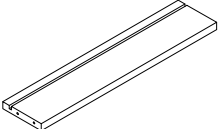
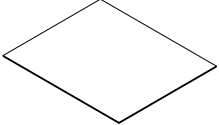
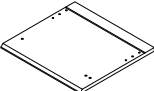
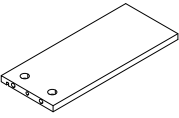

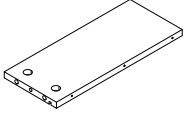
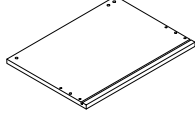
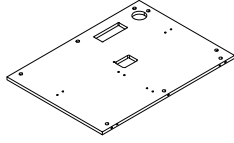
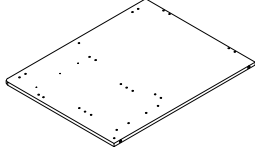
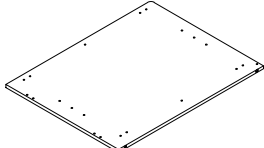
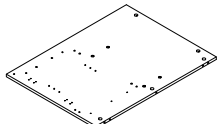
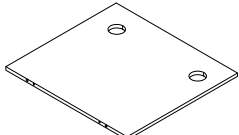
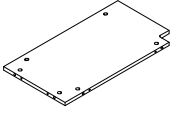
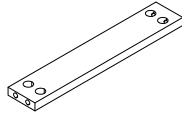
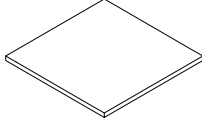



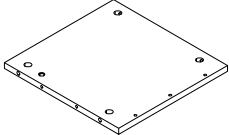
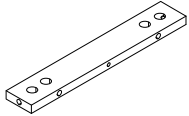
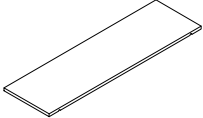
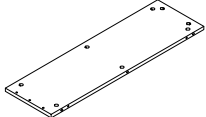
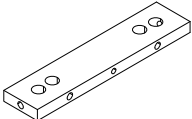
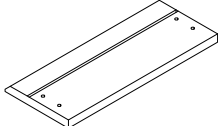
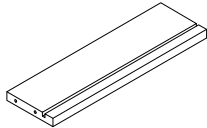
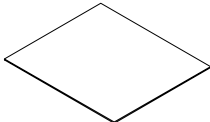
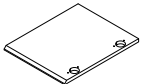





ID	Parts	QTY
21		1
22		1
23		1
24		1
25		2
26		2
27		1
28		2
29		1
30		1

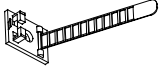





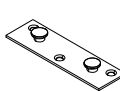

ID	Parts	QTY
31		1
32		1
33		1
34		1
35		1
36		1
37		1
38		1
39		1
40		1

Hardware List

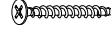
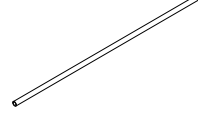
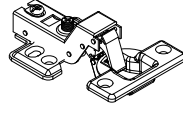

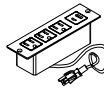
ID	Parts	QTY
41		1
42		1
43		1
44		1
45		1
46		1
47		1
48		1
49		1

Hardware List

ID	Parts	QTY
A	M6*55mm 	10+3
B	M6*10mm 	18+1
C	M6*8mm 	6+1
D	Ø5*12mm 	14+1
E		3+2
F	Ø6*33.5mm 	99+9
G	Ø15*9.5mm 	99+9
H	Ø6*30mm 	65+6
I	   I1x2 I2x2 I3x4	1 SET
J	Ø3.5*12mm 	66+6

ID	Parts	QTY
K		8
L		8
M	Ø4*38mm 	12+1
N		2
O		2
P		12+1
Q		1
R		1
S		2
T	 M4	1

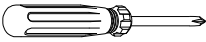
Hardware List

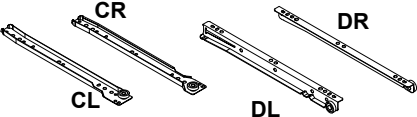
ID	Parts	QTY
Z1		1
Z2		1
		3 SET

Parts List

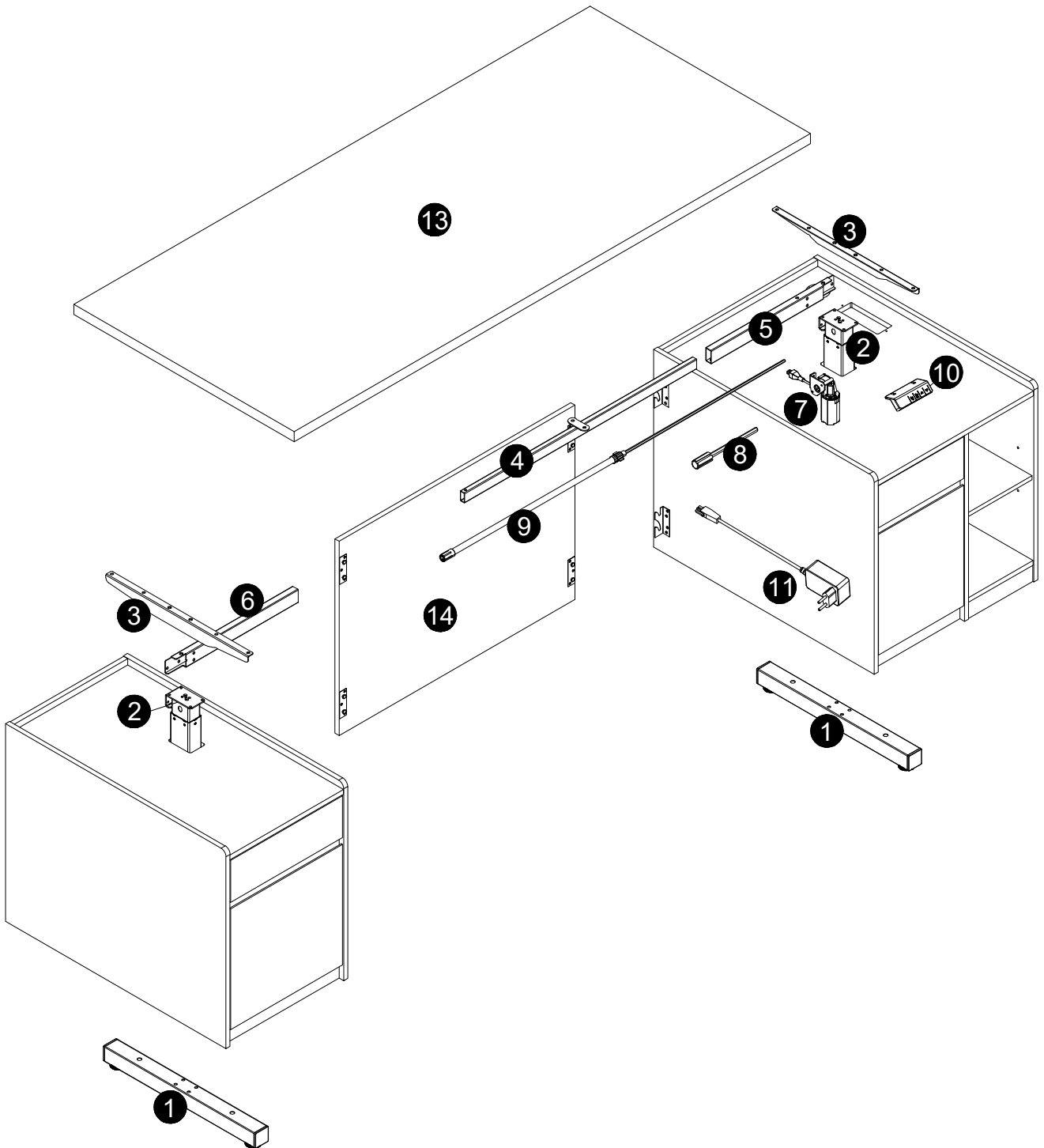

Parts List

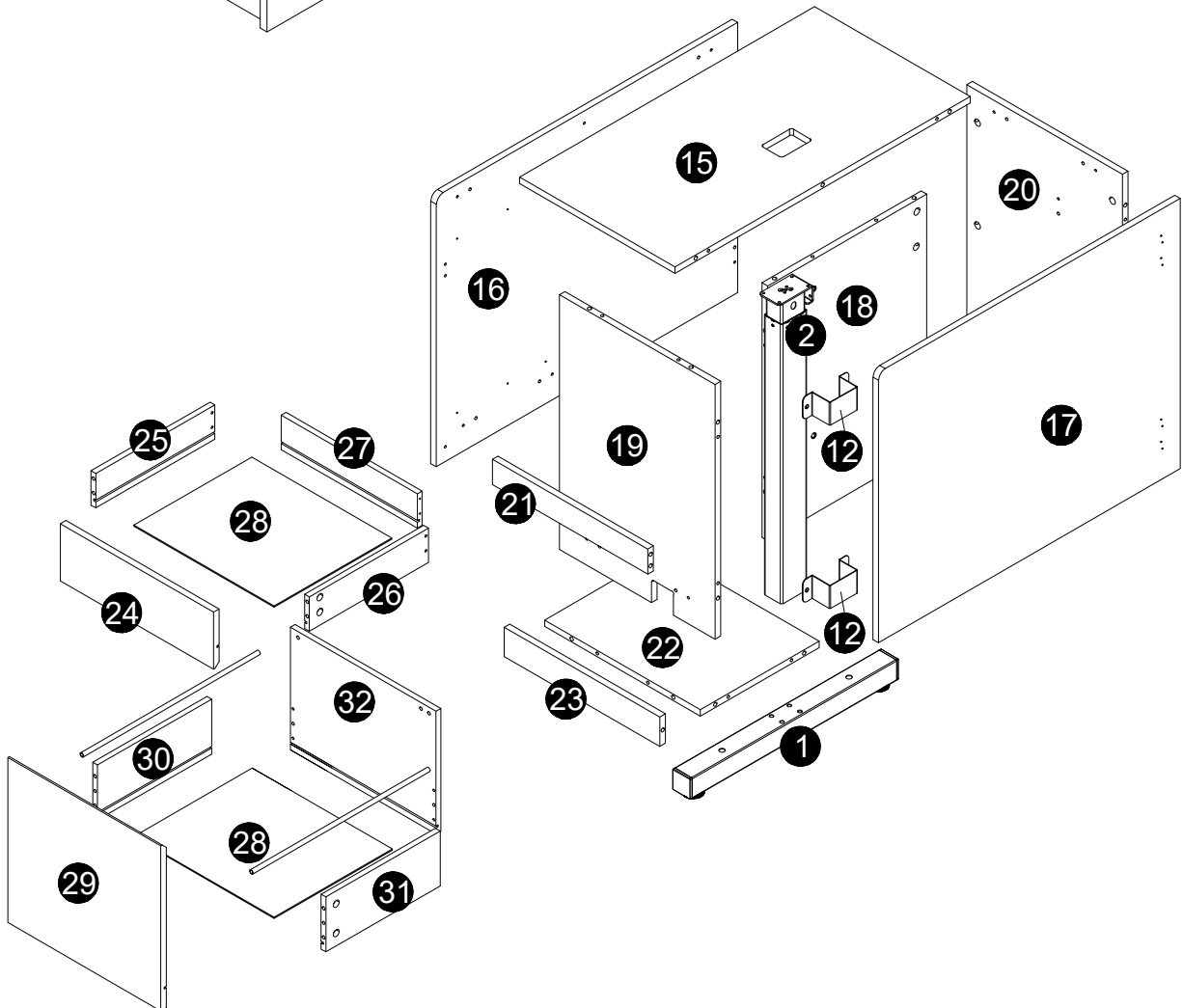
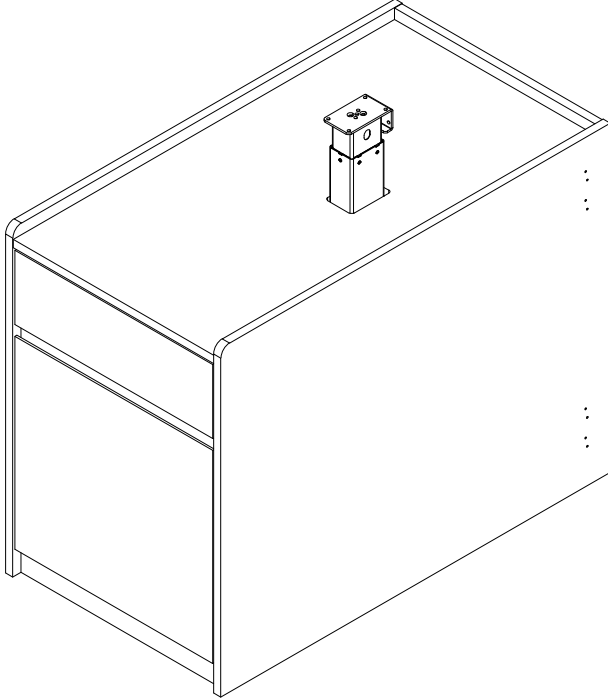

Parts List

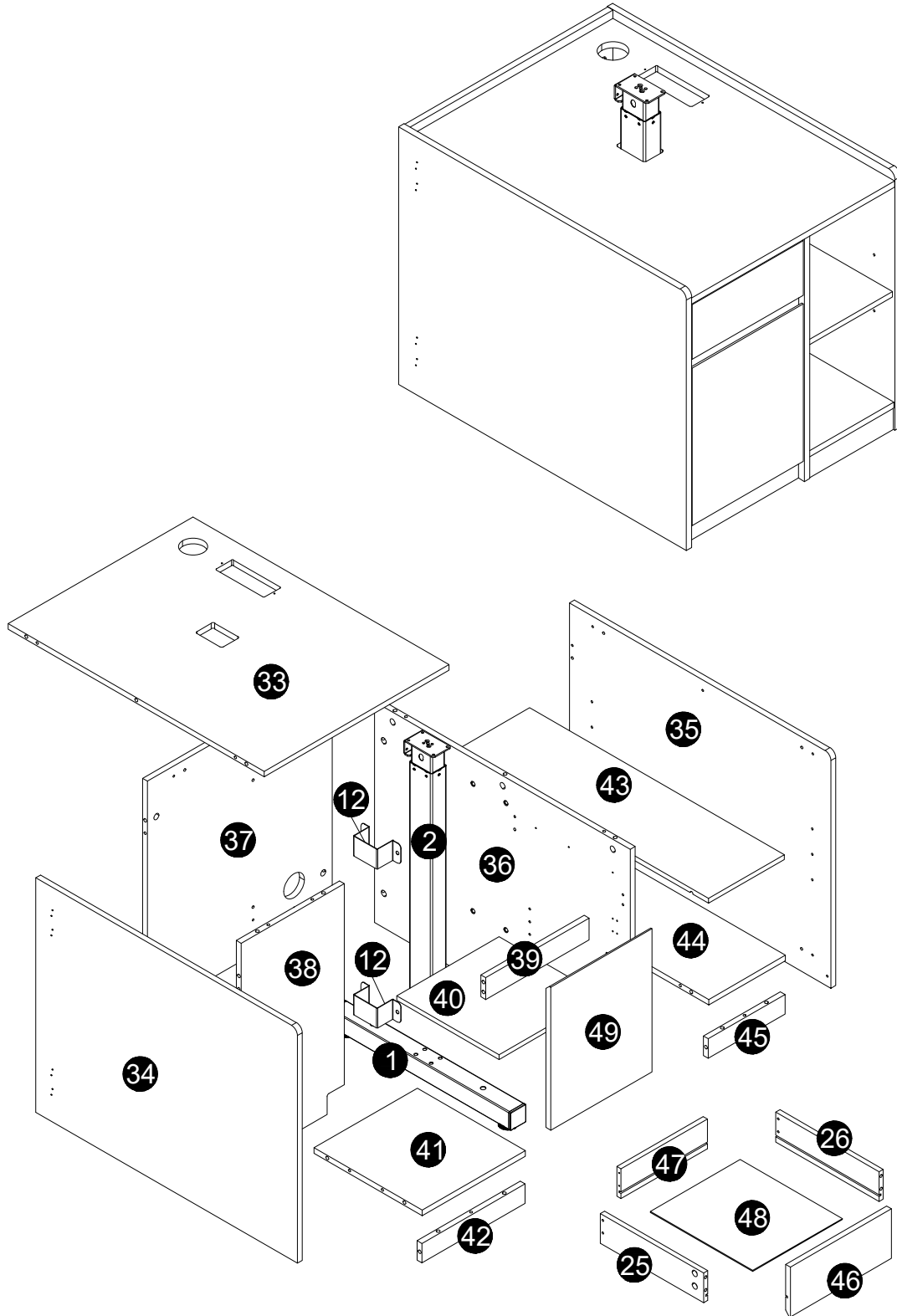

STEP 1

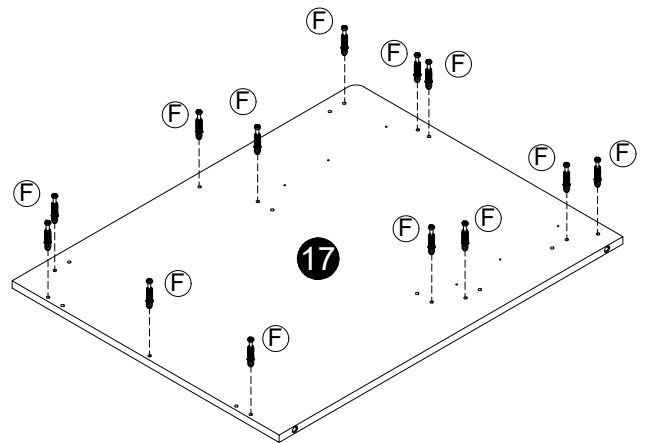
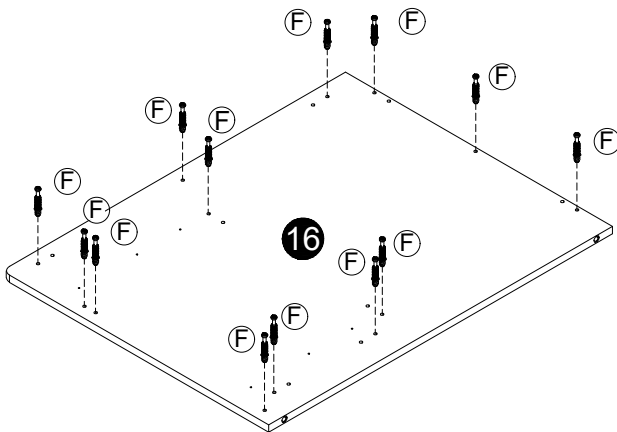
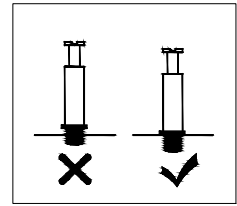
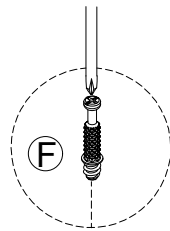

STEP 2

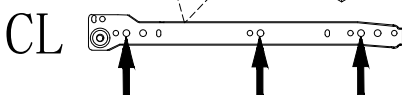
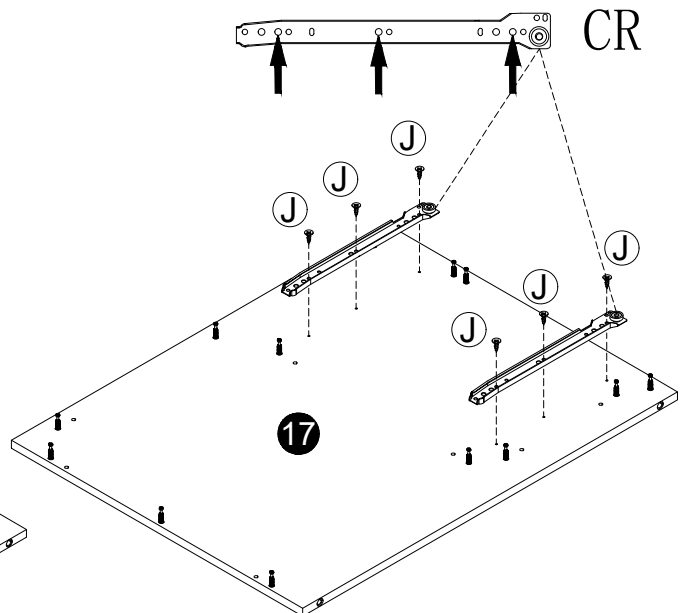
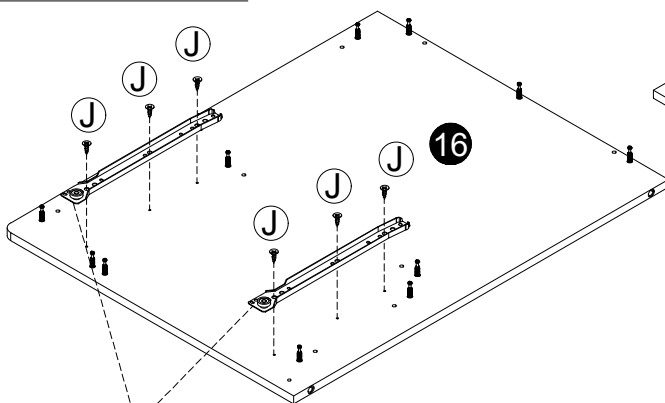
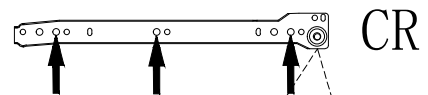

STEP 3

 **F** X6

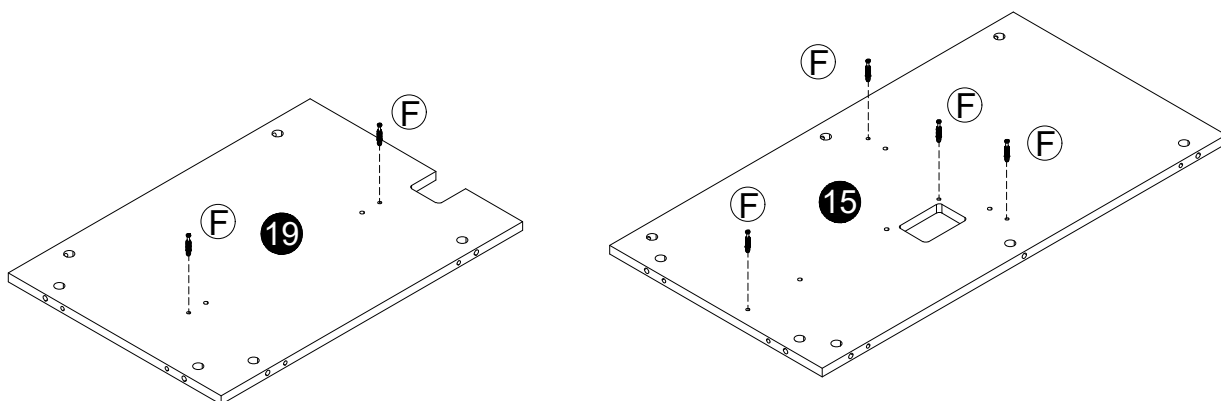
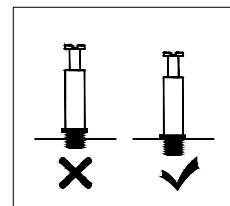
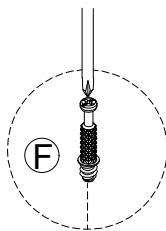

STEP 4

 **F** X6

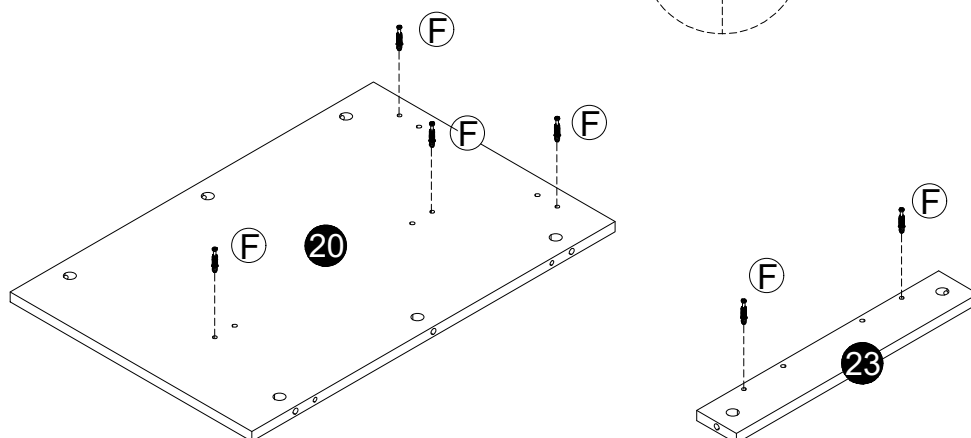
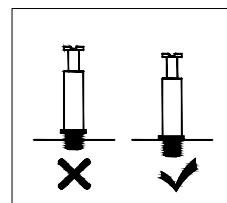
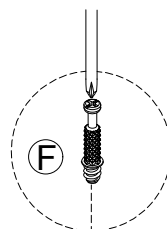

STEP 5



G X2



H X2

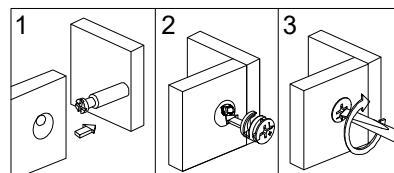
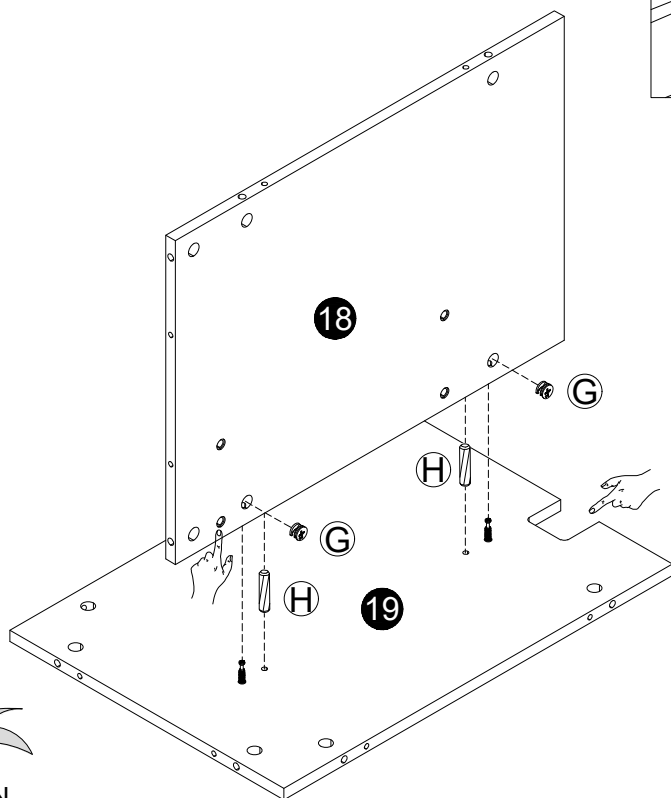

STEP 6



G X4



H X4

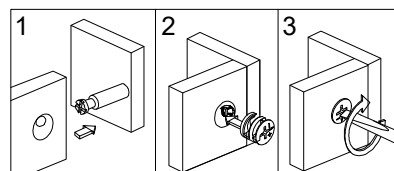
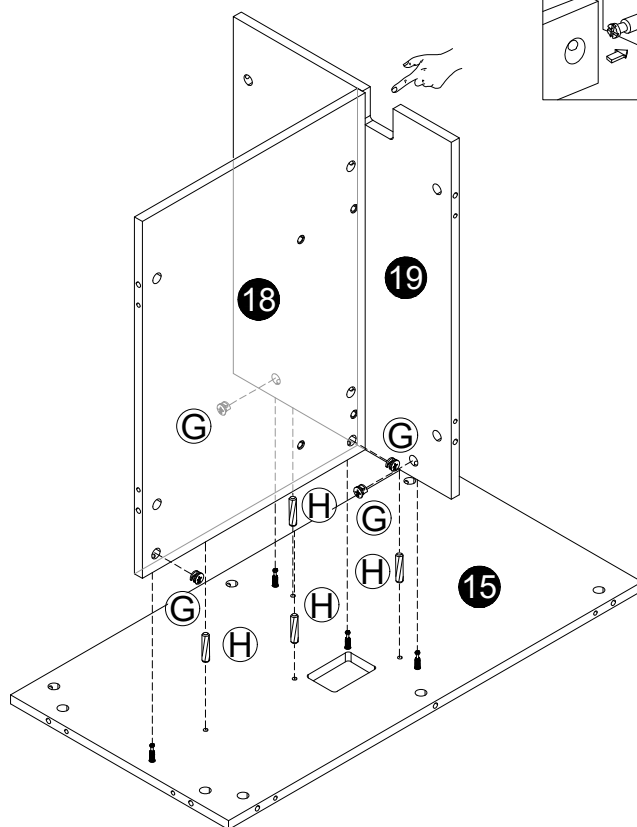

STEP 7



G X4

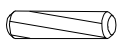

H X4

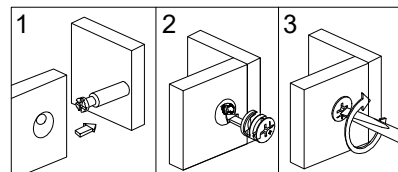
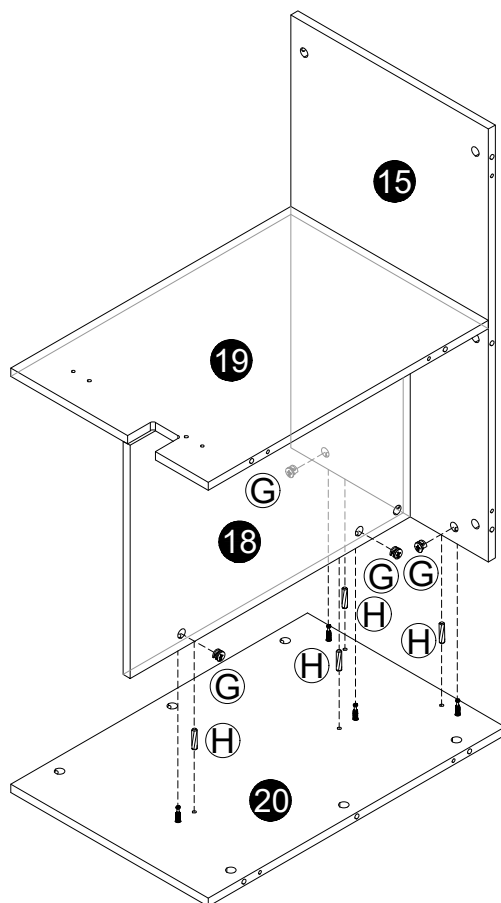

STEP 8



F X2

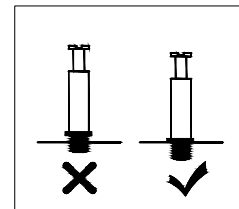
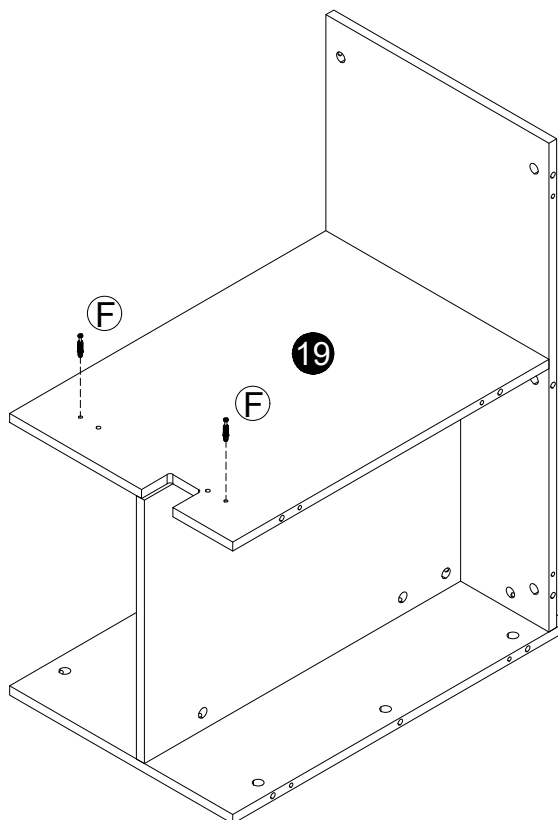
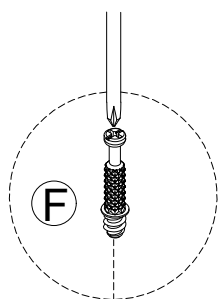

STEP 9



G X2

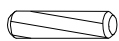

H X2

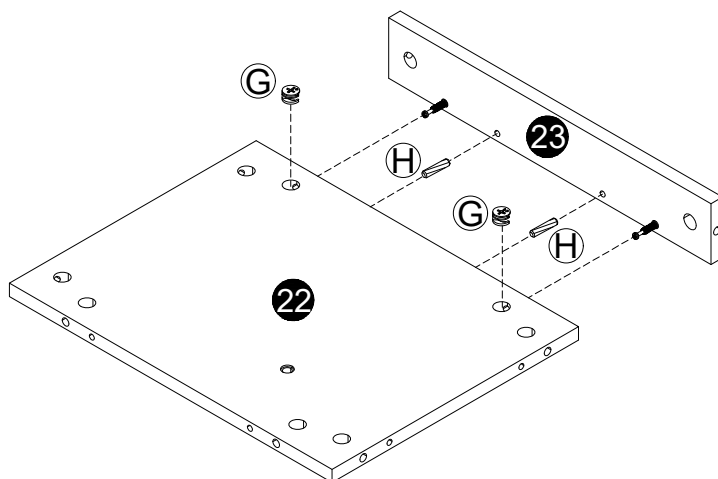
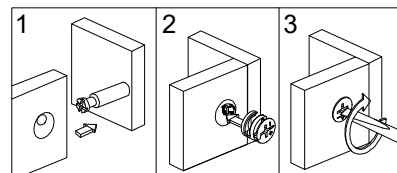

STEP 10



G X2

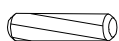

H X2

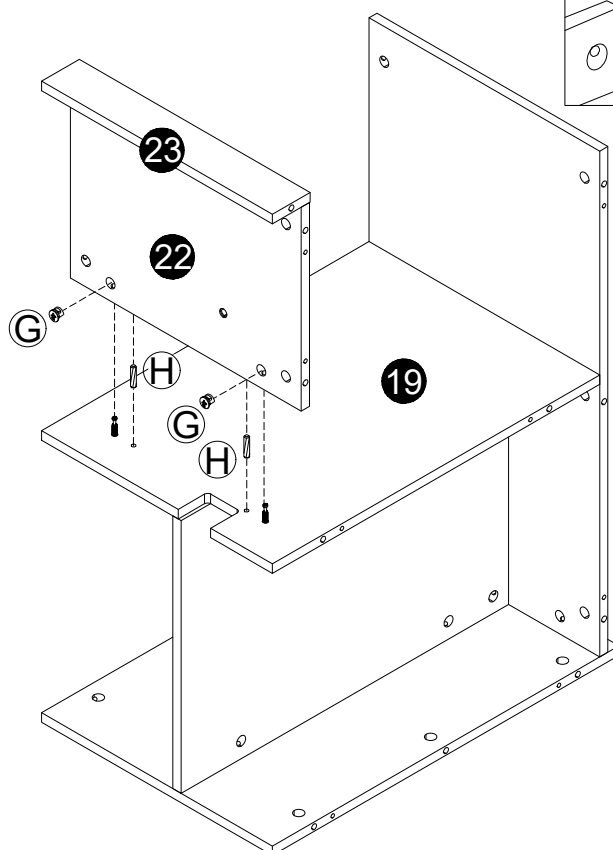
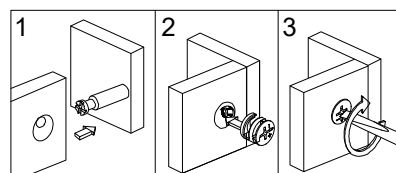

STEP 11



G X2

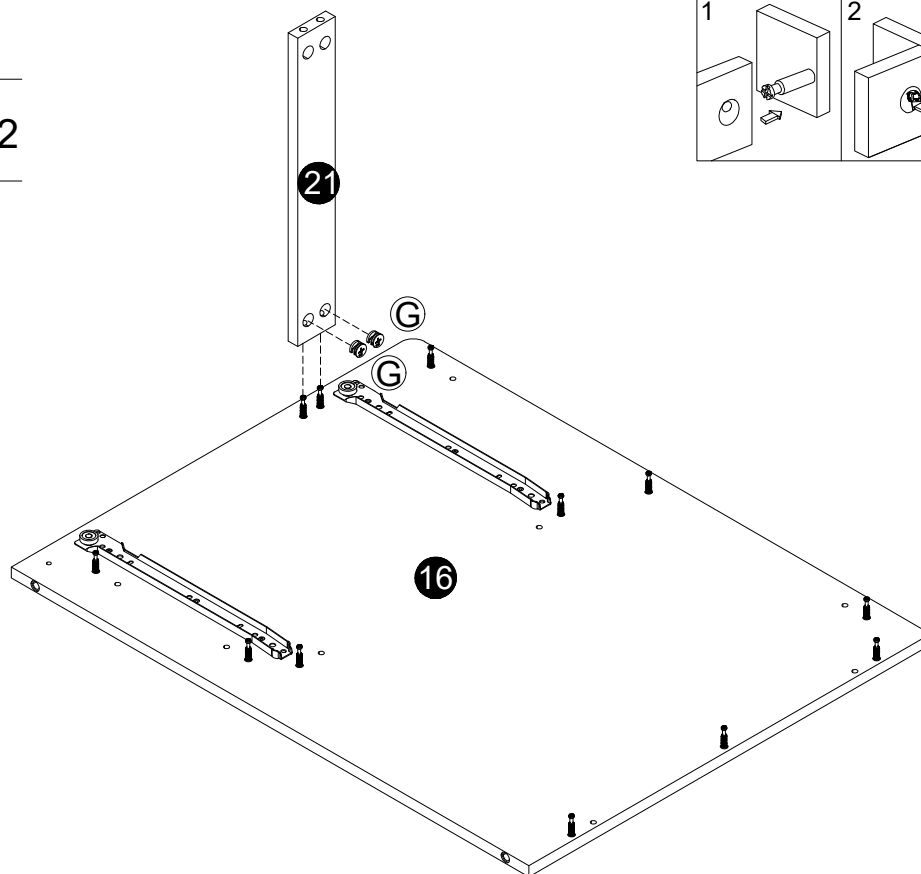
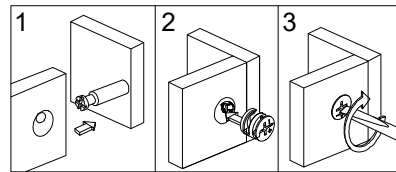

STEP 12



G X11

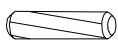

H X8

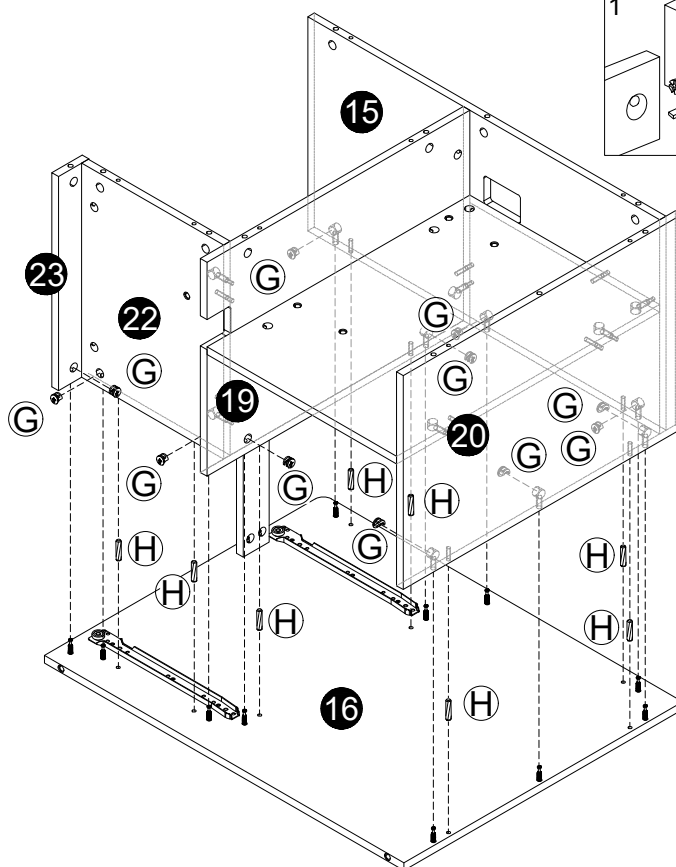
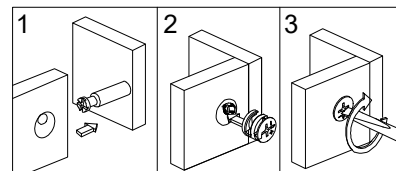

STEP 13

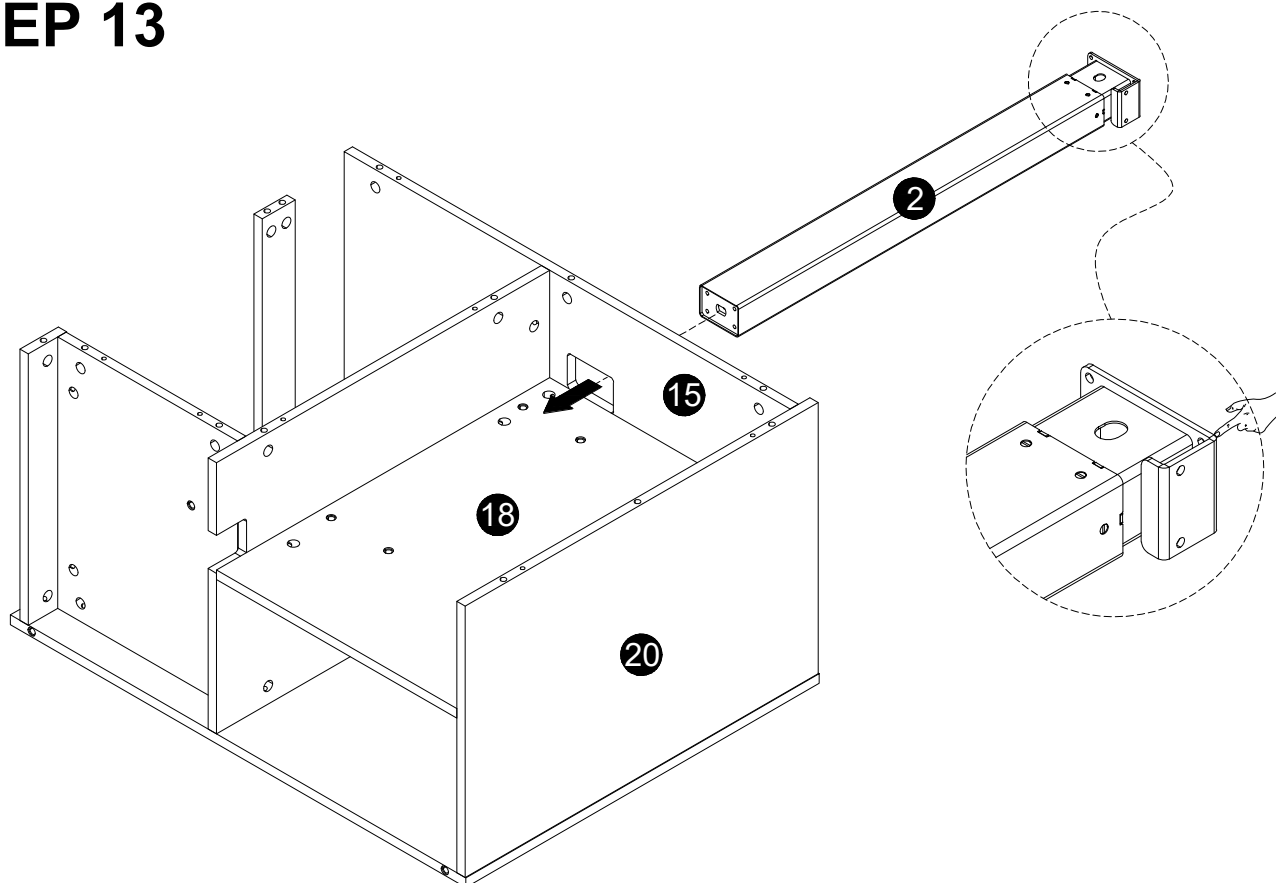

STEP 14

 **A** X5

 **T**
M4

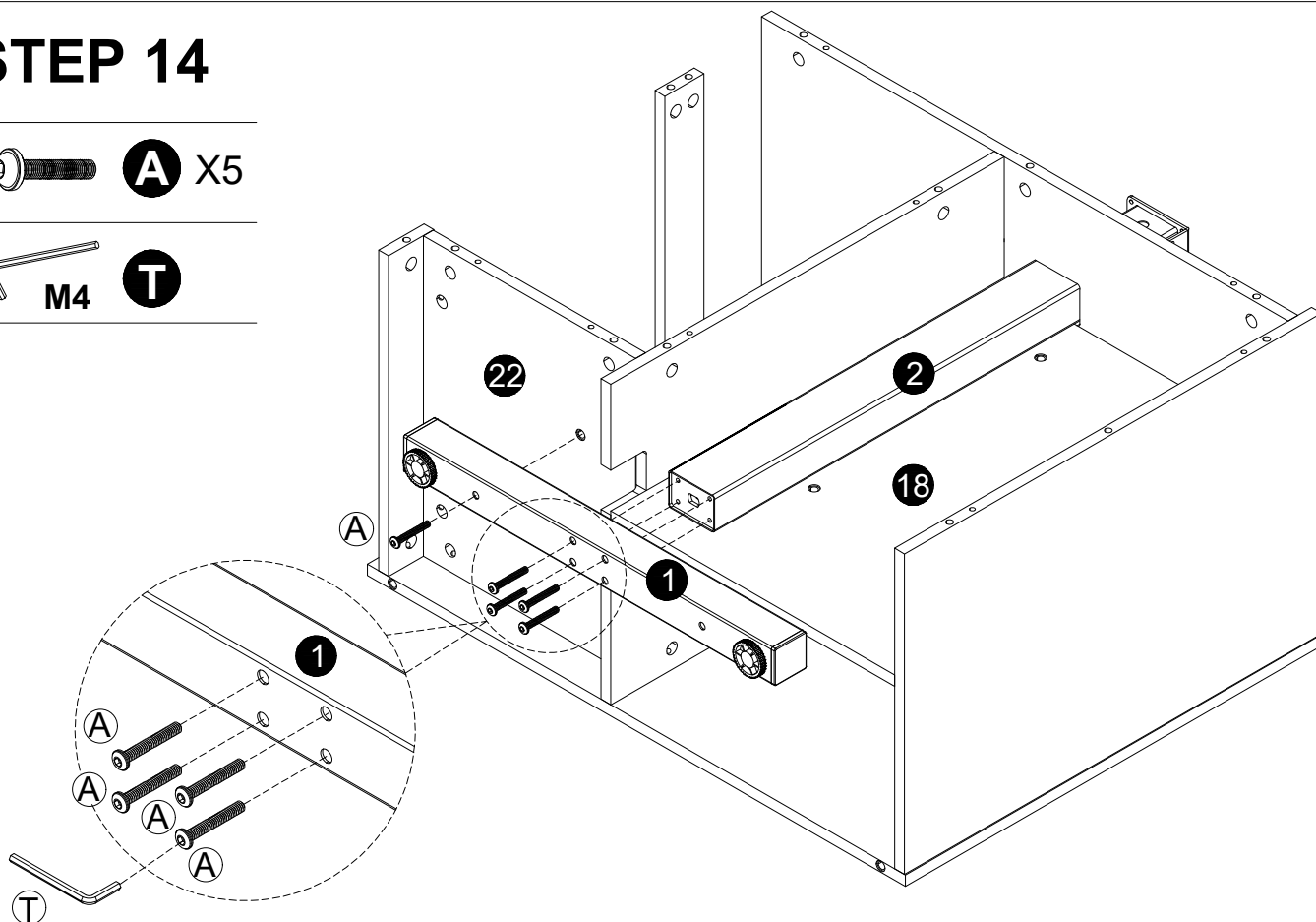

STEP 15

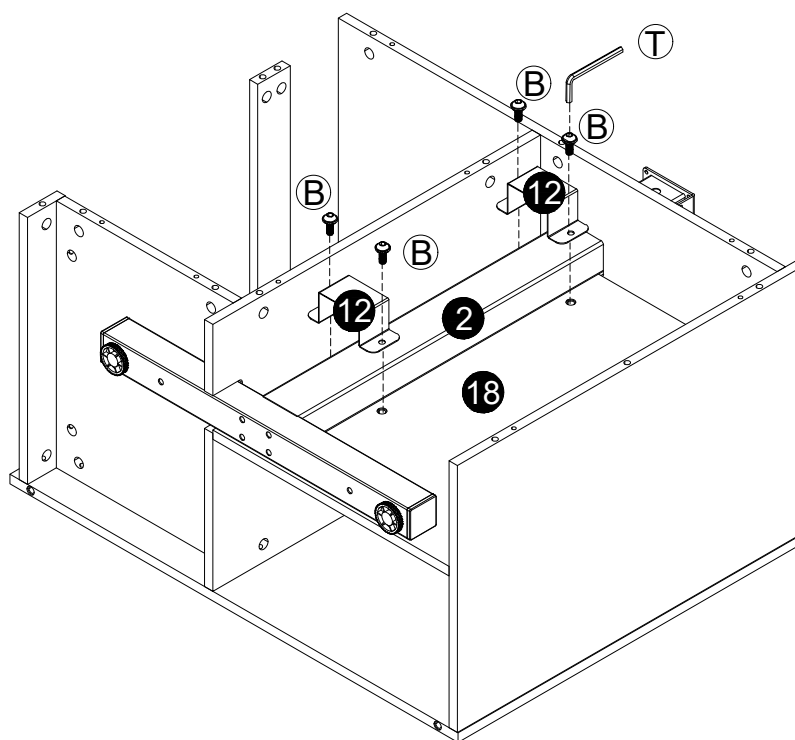

STEP 16

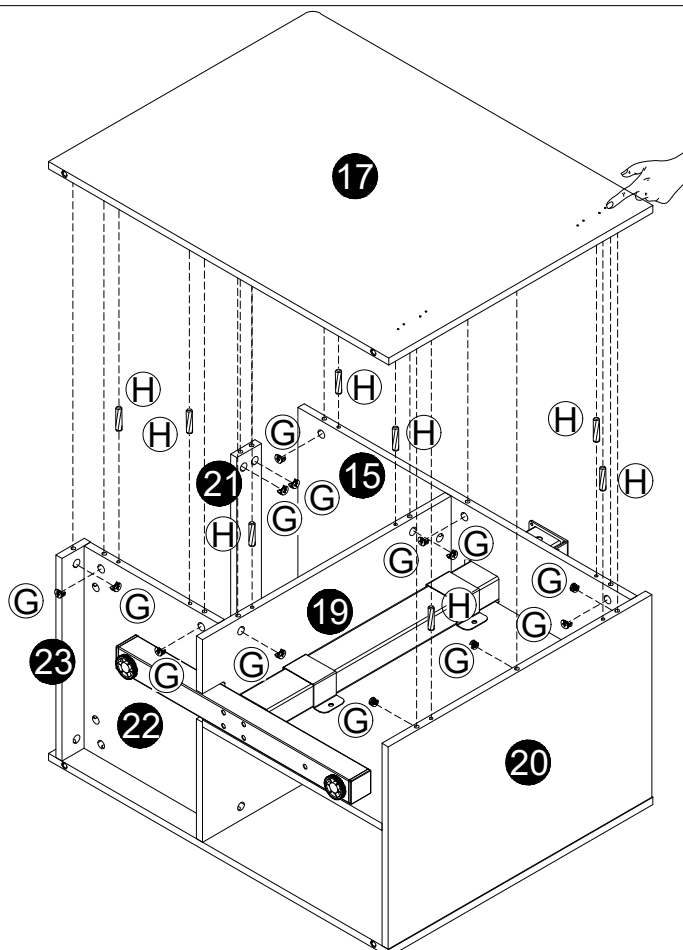

STEP 17



I1 X2



J X8

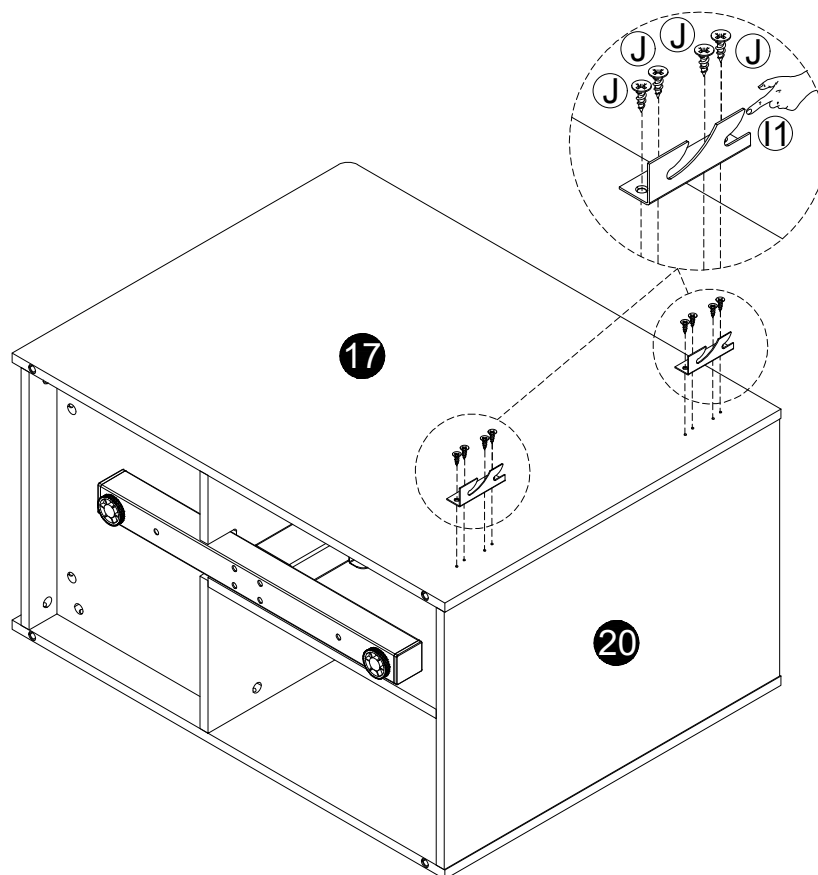

STEP 18



K X4

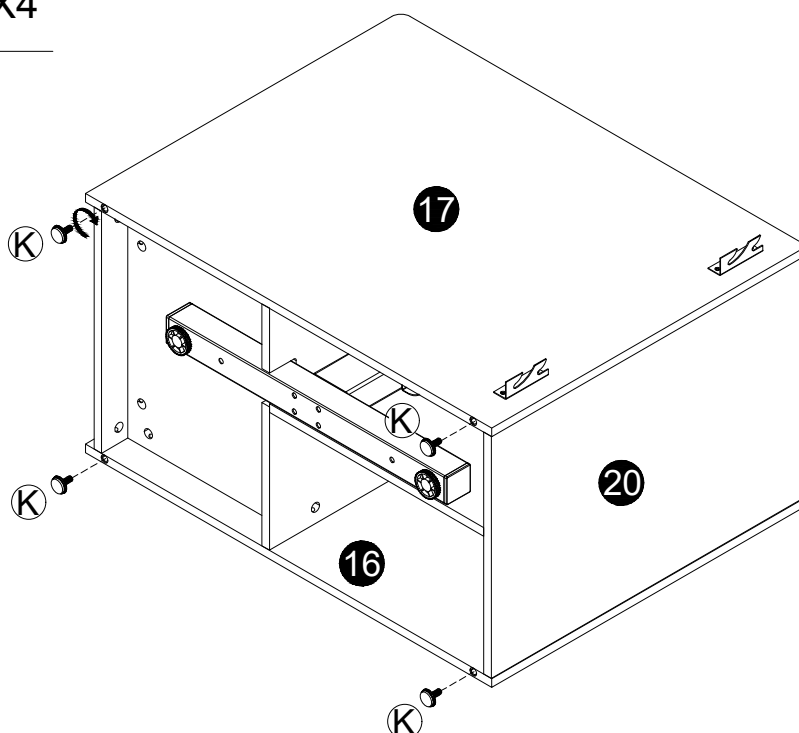

STEP 19

 **F** X11

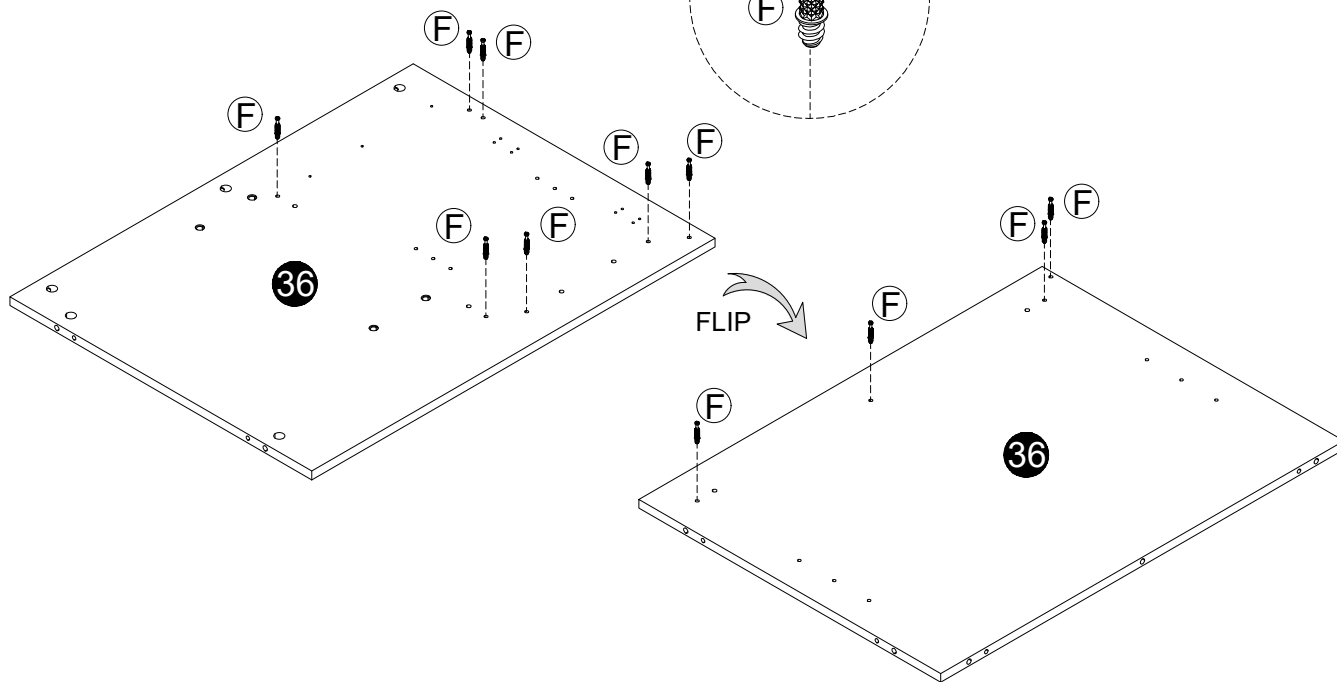
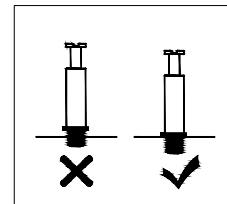

STEP 20

 **CR** X1

 **J** X3

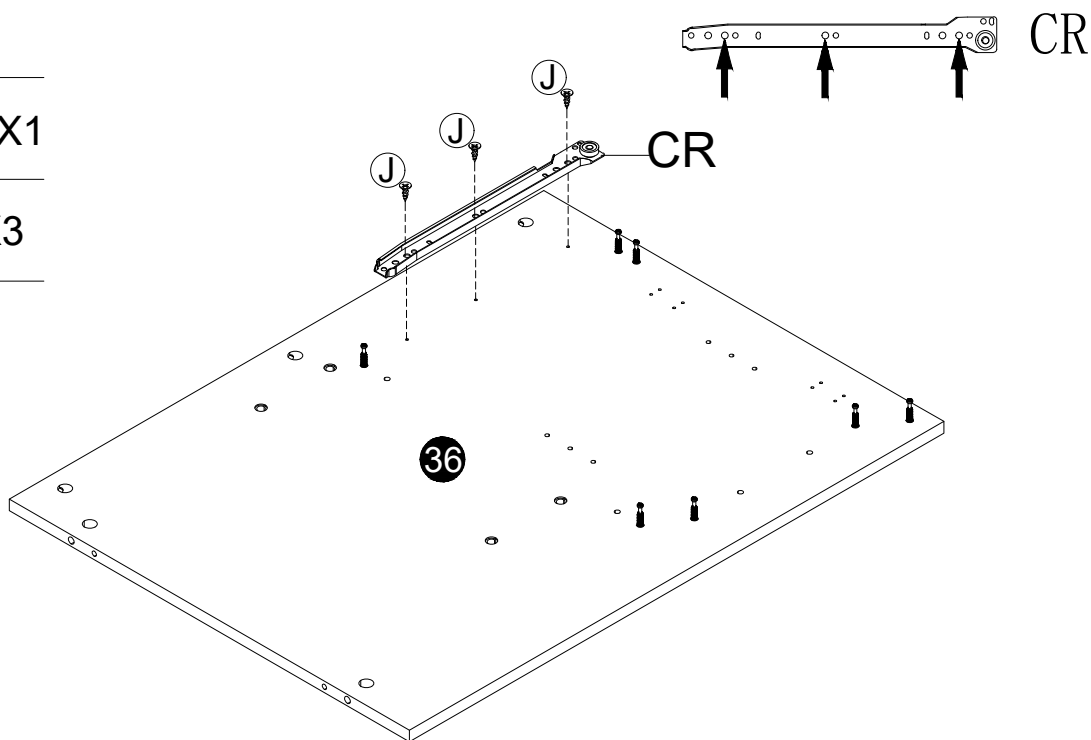

STEP 21

 **F** X12

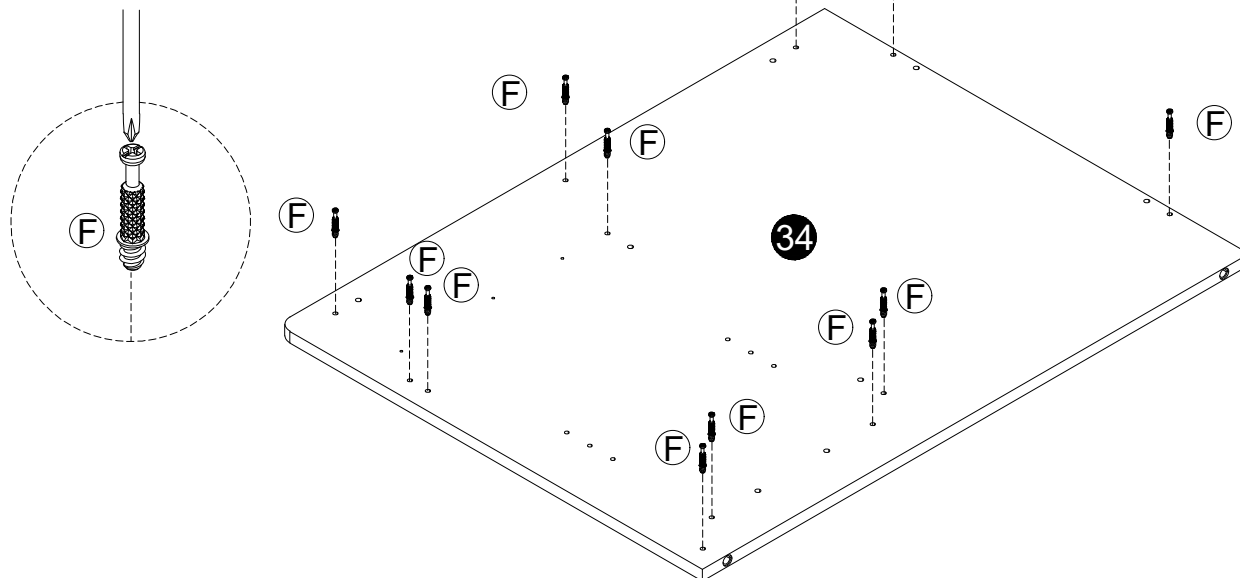
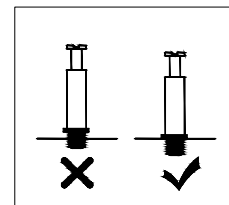

STEP 22

 **CL** X1

 **J** X3

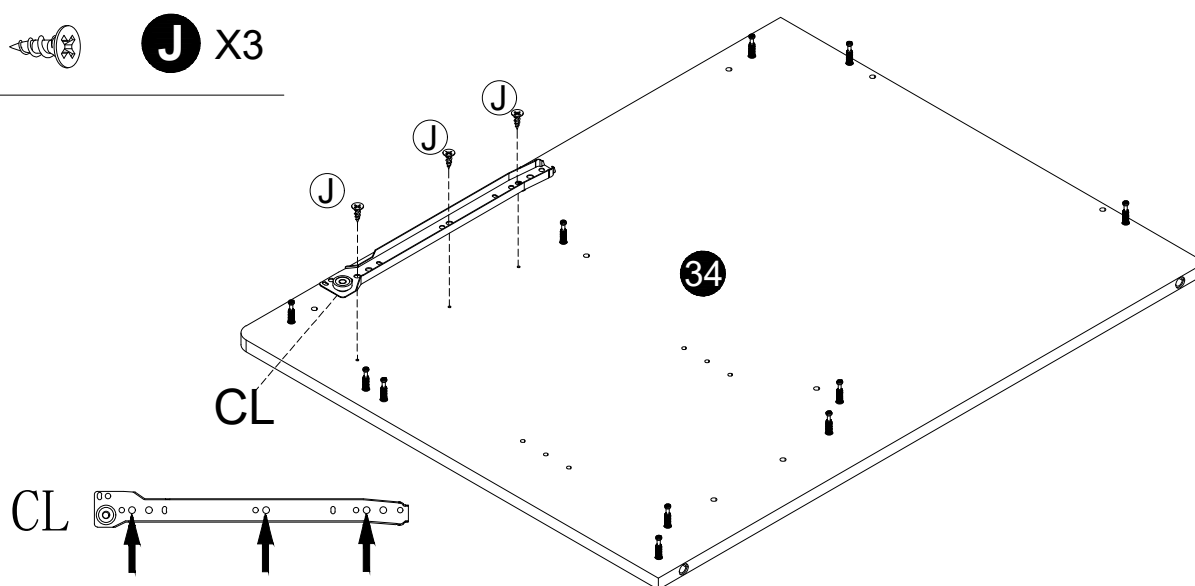

STEP 23

 **F** X4

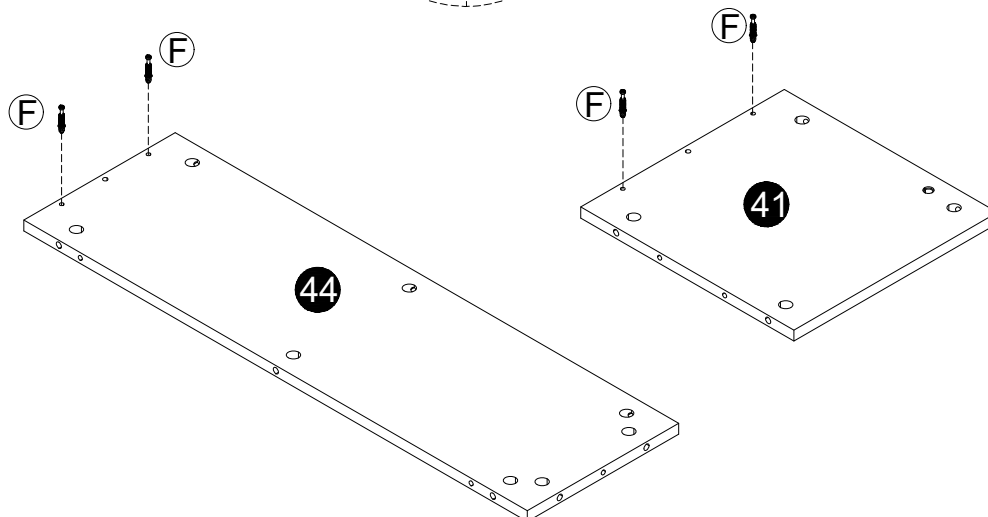
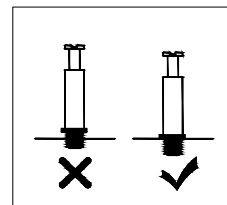
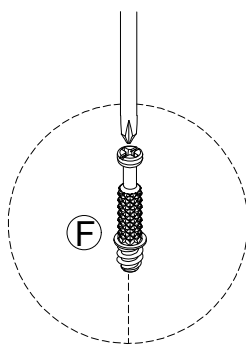

STEP 24

 **G** X4

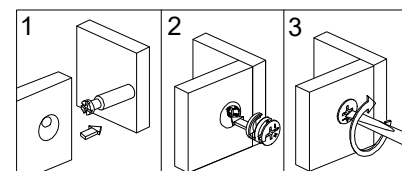

 **H** X2

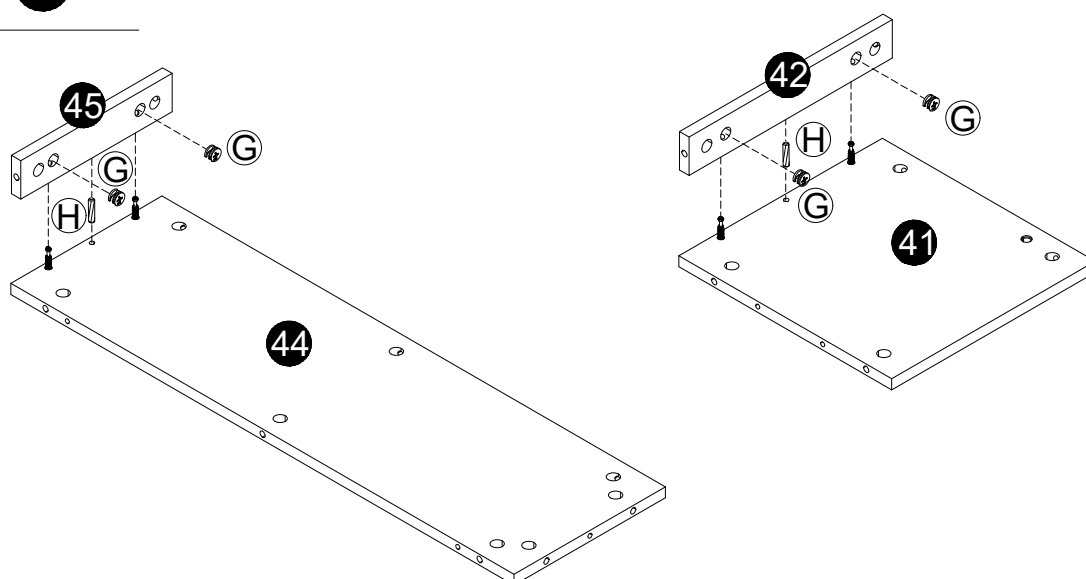

STEP 25

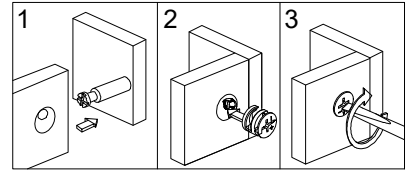

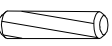

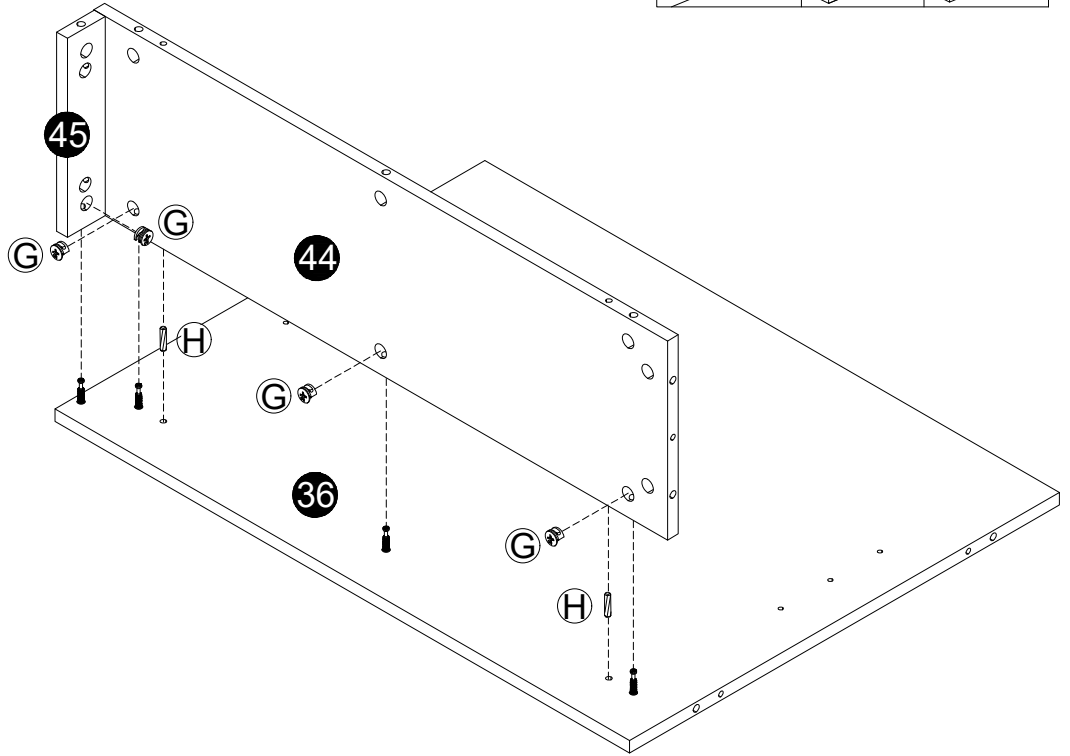
-  **G** X4
-  **H** X2

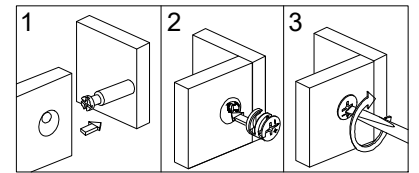

STEP 26



-  **G** X5
-  **H** X2

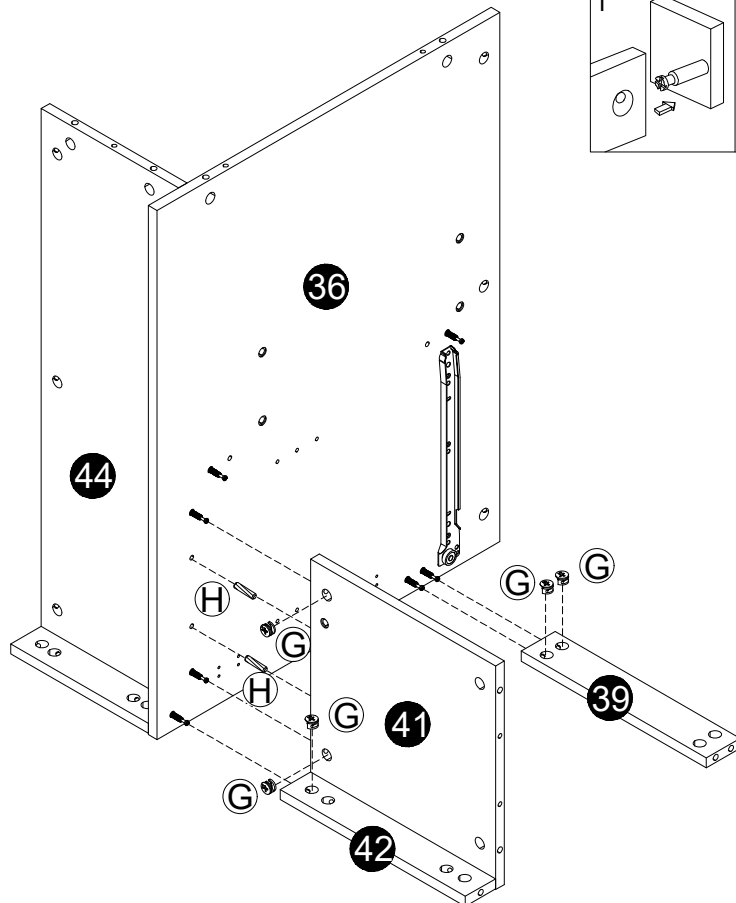

STEP 27



G X2

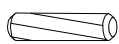

H X2

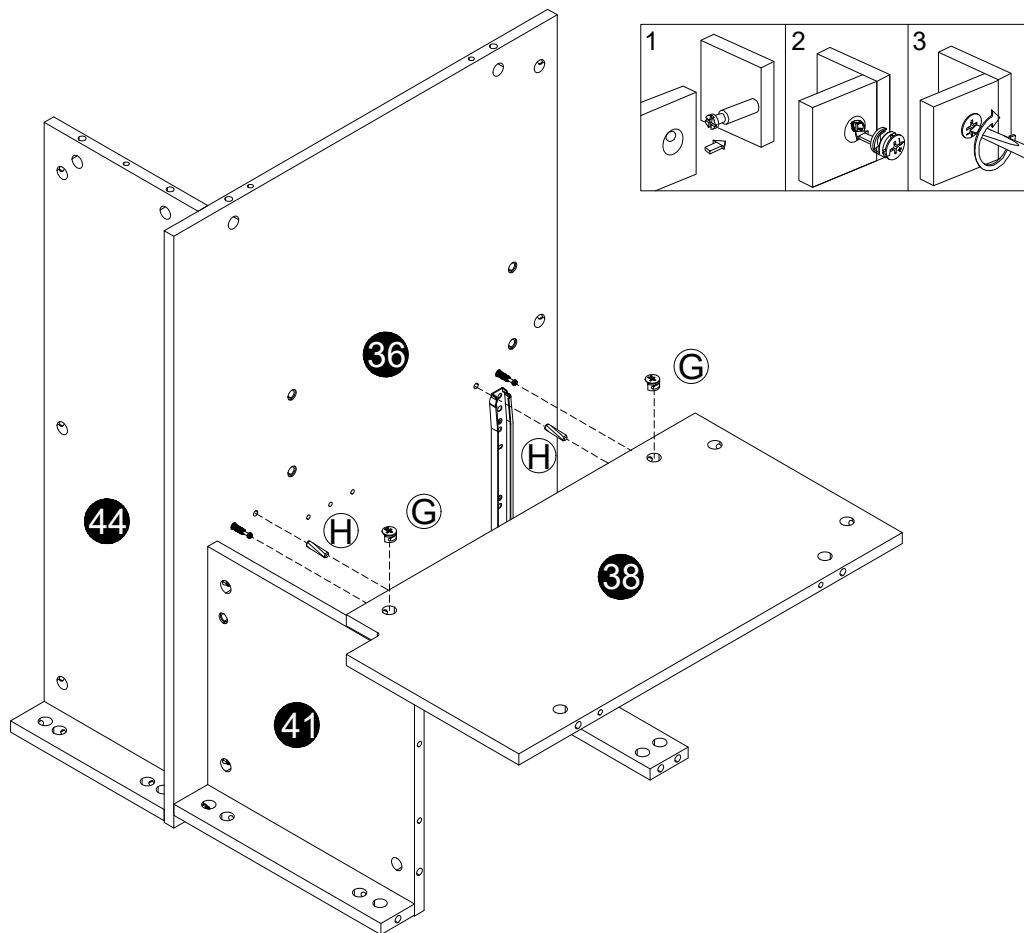

STEP 28



F X11

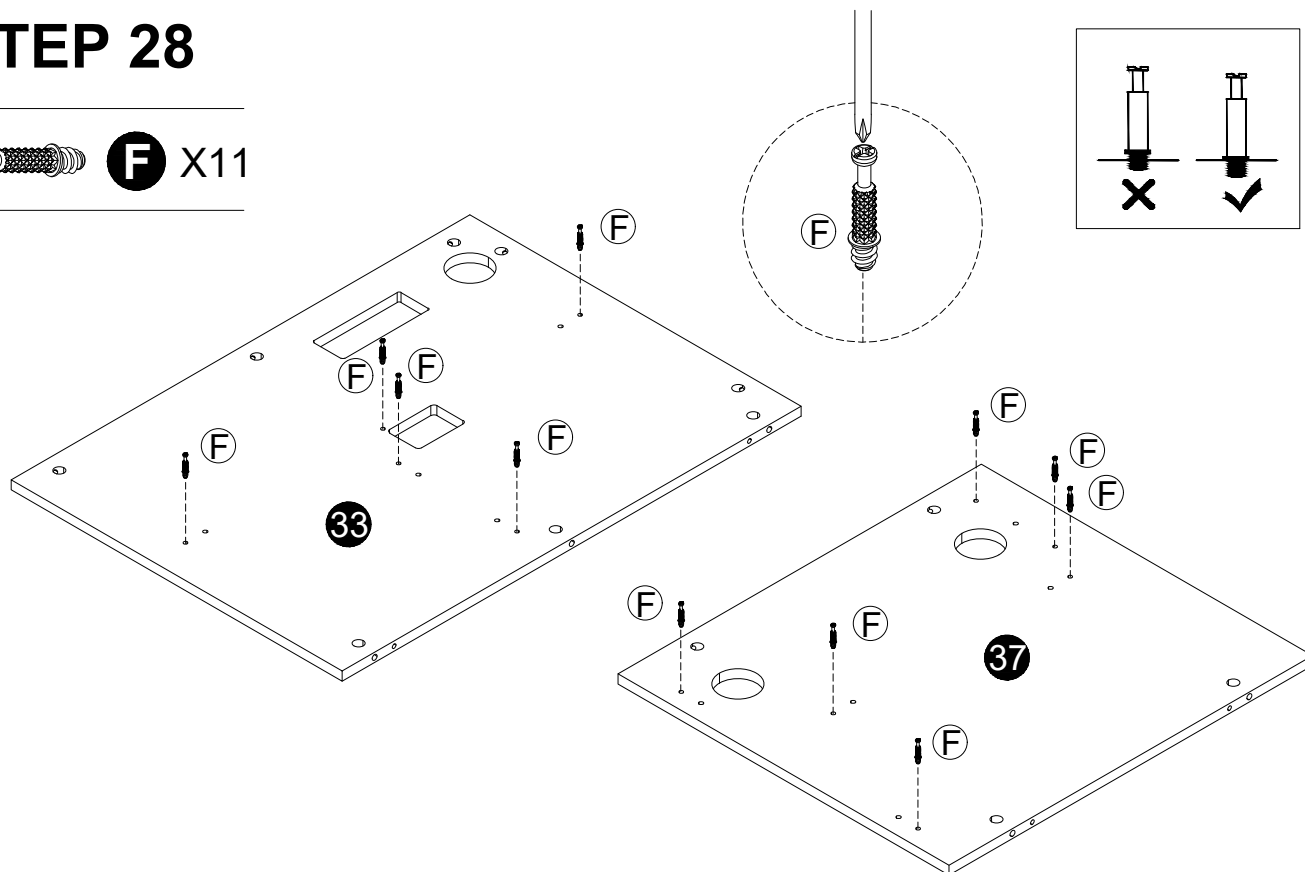

STEP 29



G X5

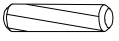

H X4

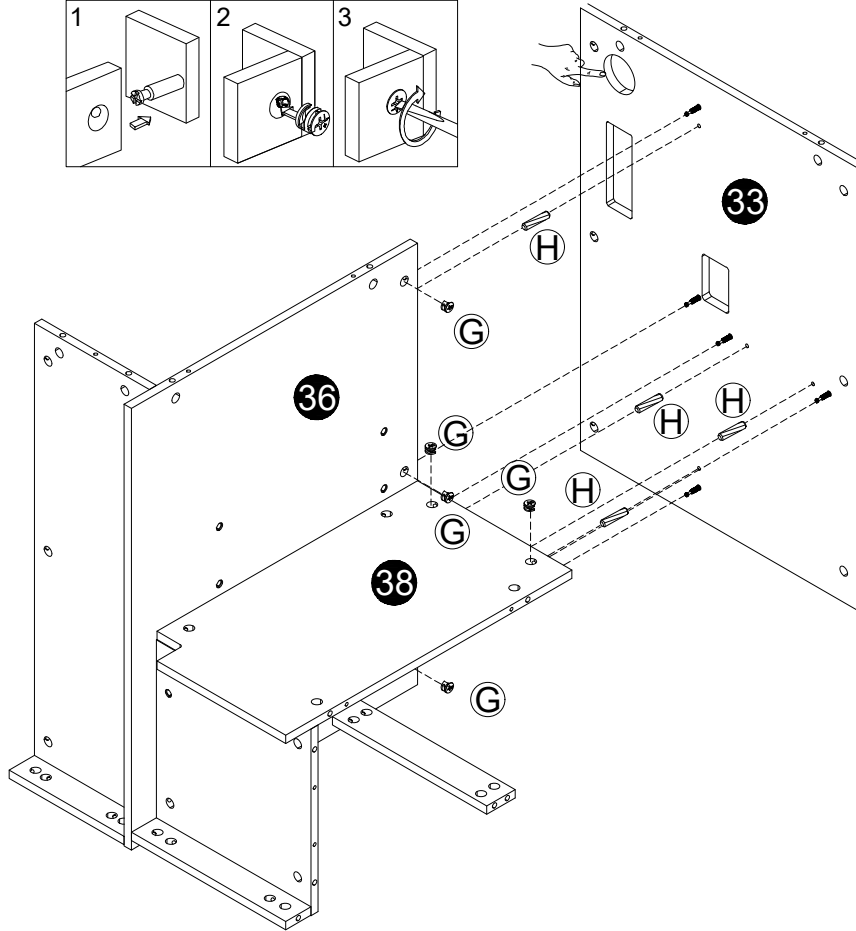
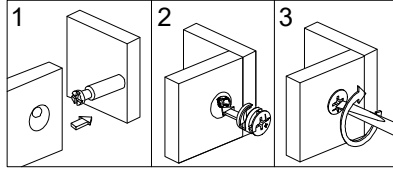

STEP 30



G X6

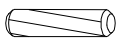

H X5

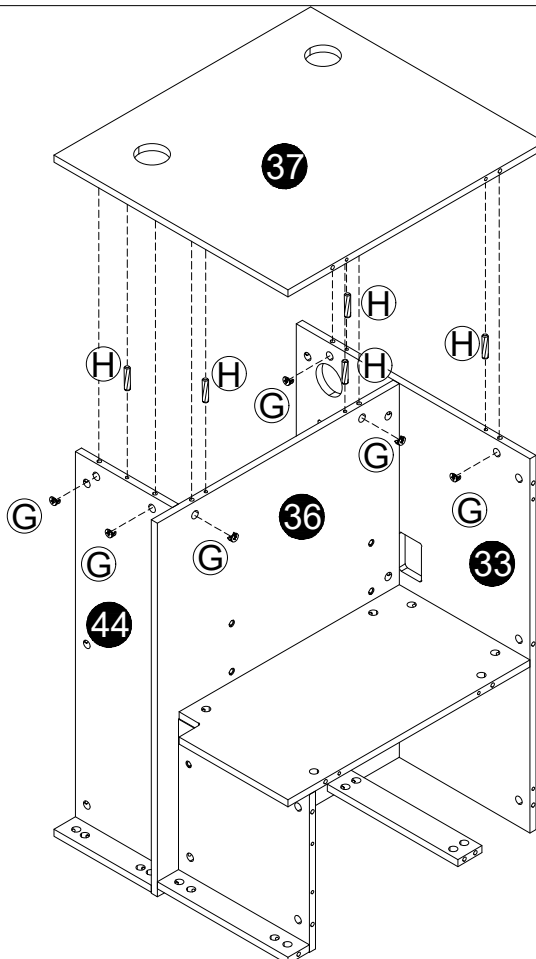
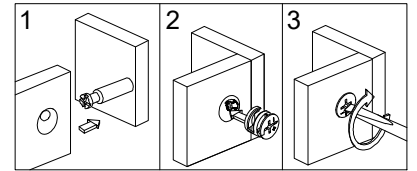

FLIP & TURN
to installation the Next Step

STEP 31

 **F** X9

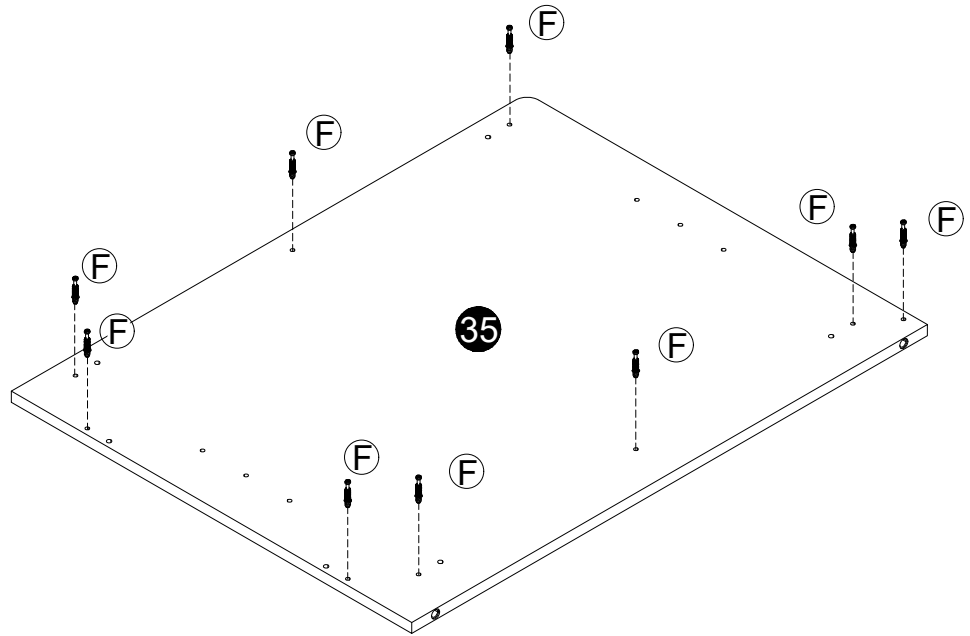
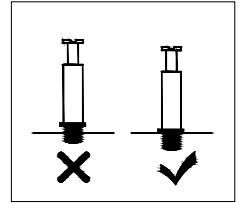
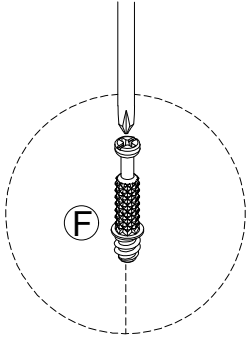

STEP 32

 **G** X9

 **H** X6

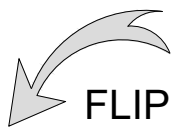
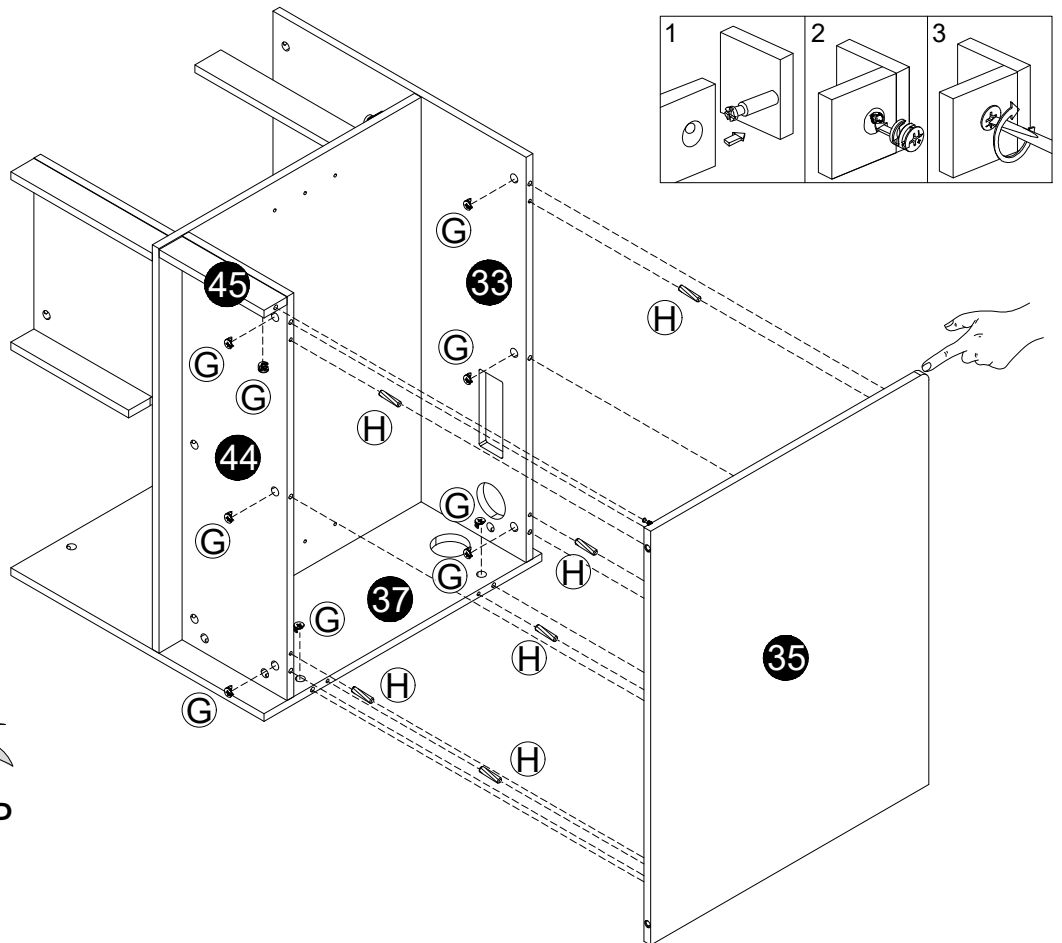
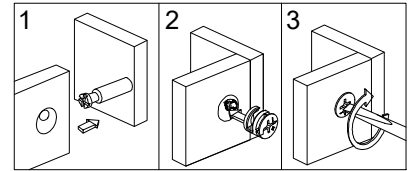

STEP 33

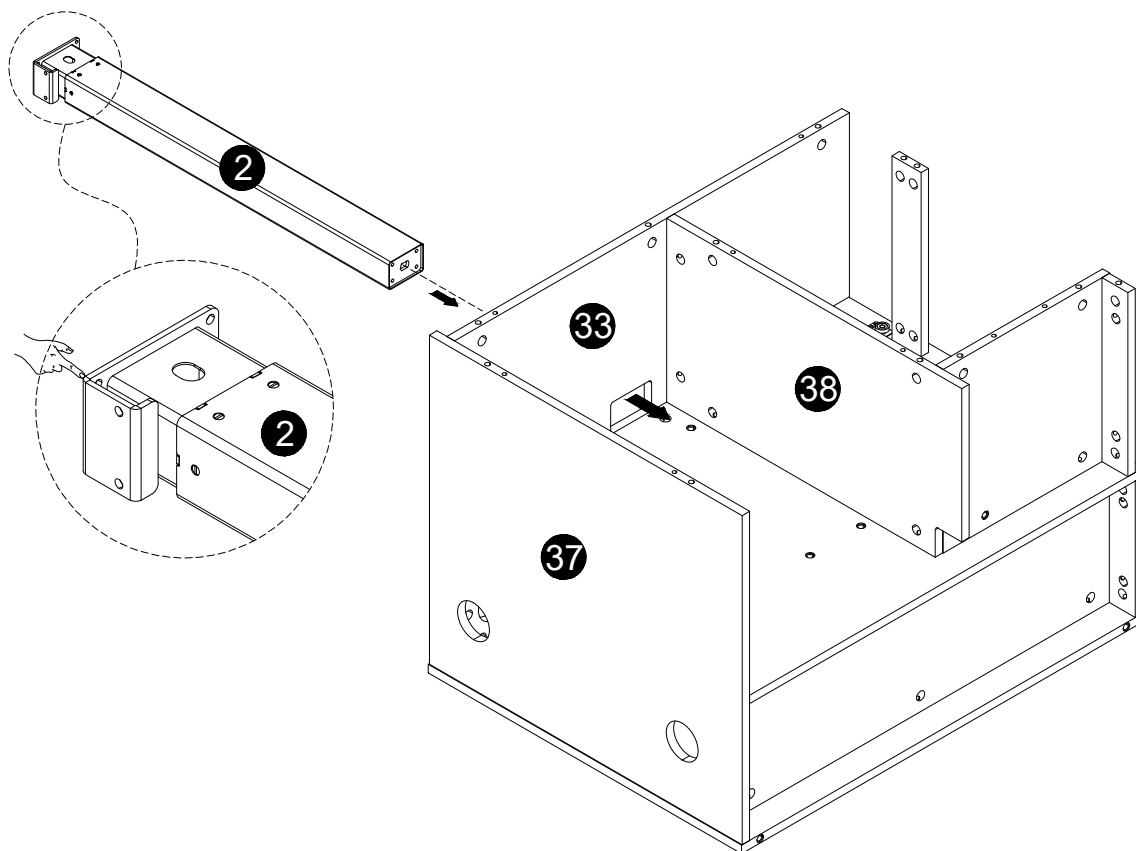

STEP 34

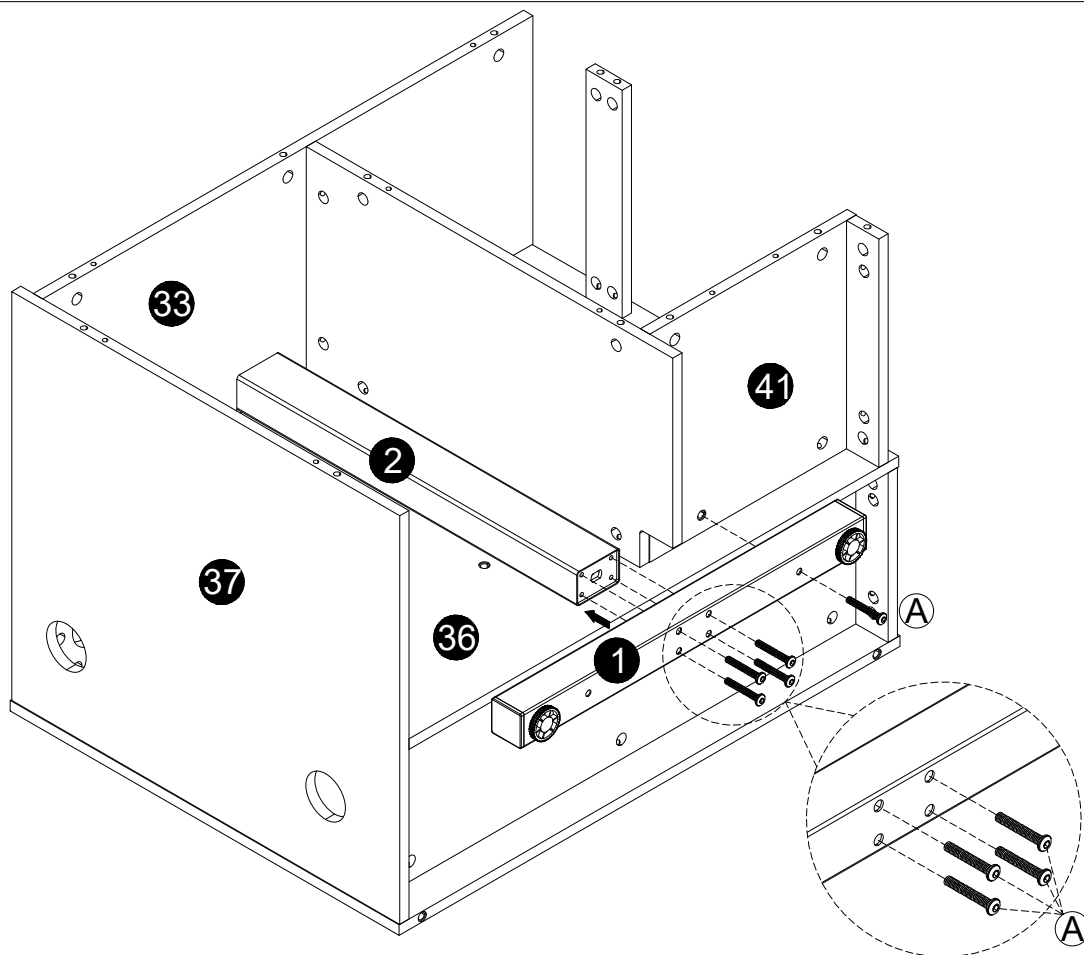
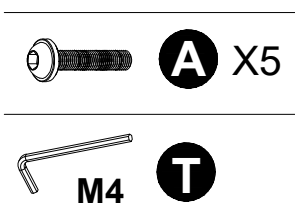

STEP 35

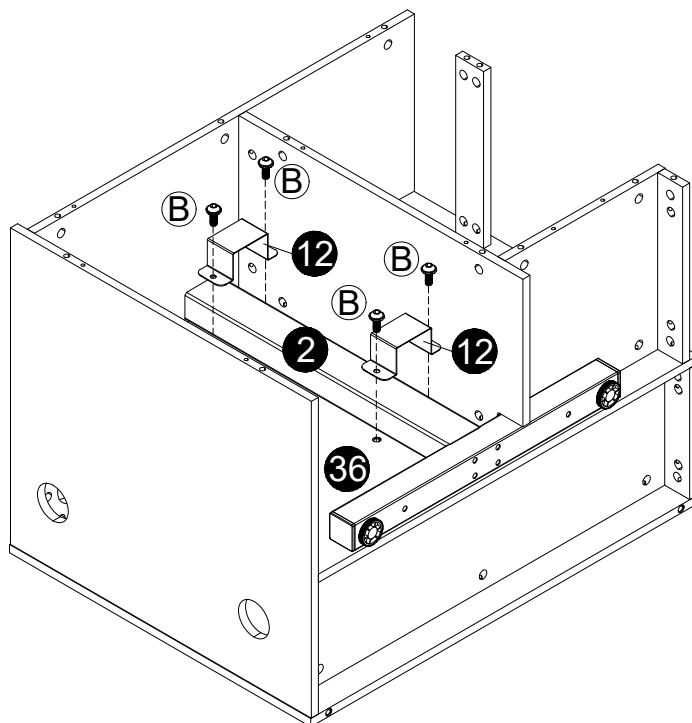

STEP 36

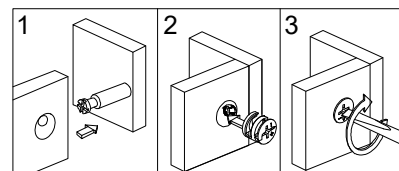
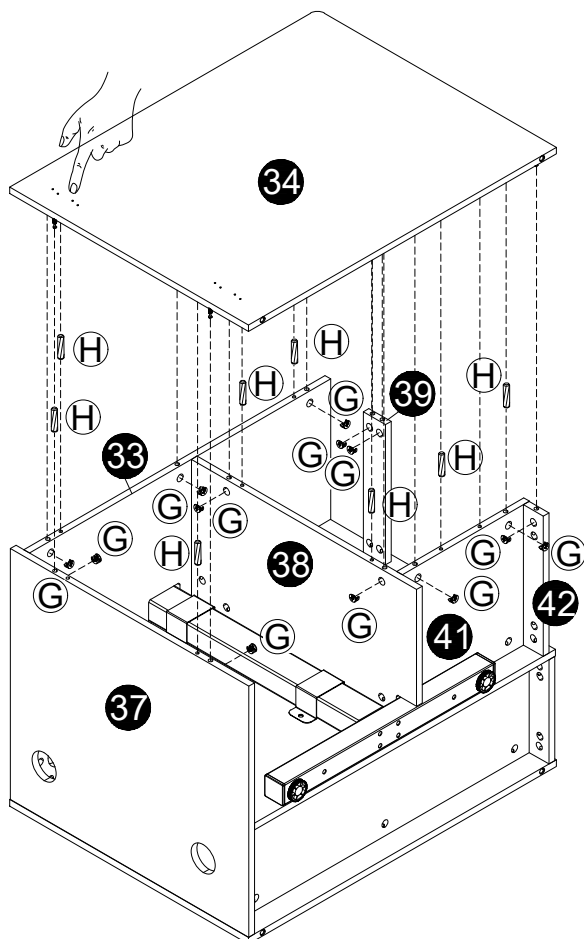

STEP 37

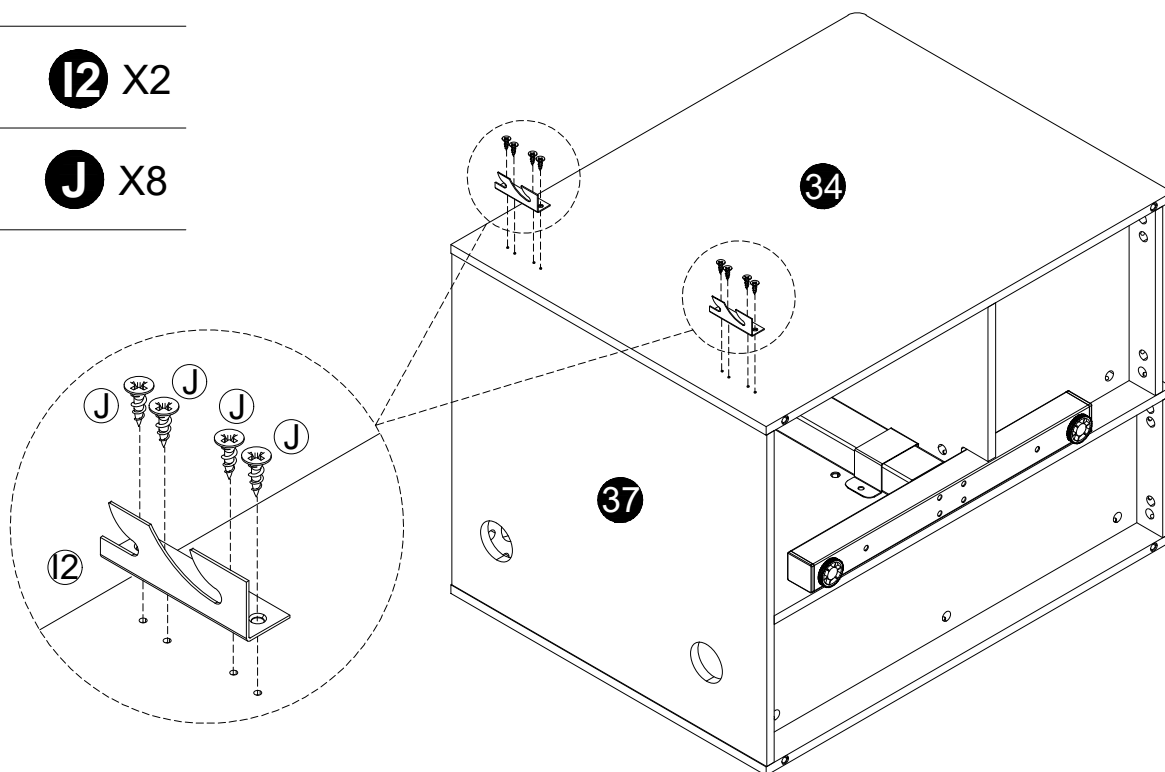
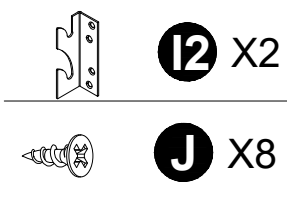

STEP 38

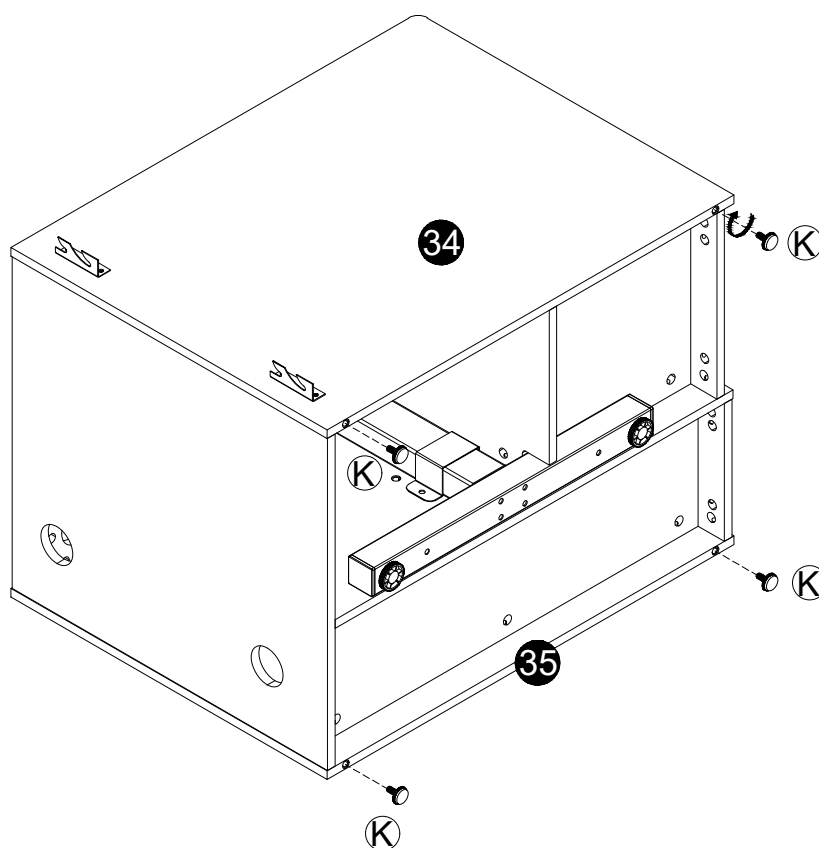

STEP 39

 **L** X8

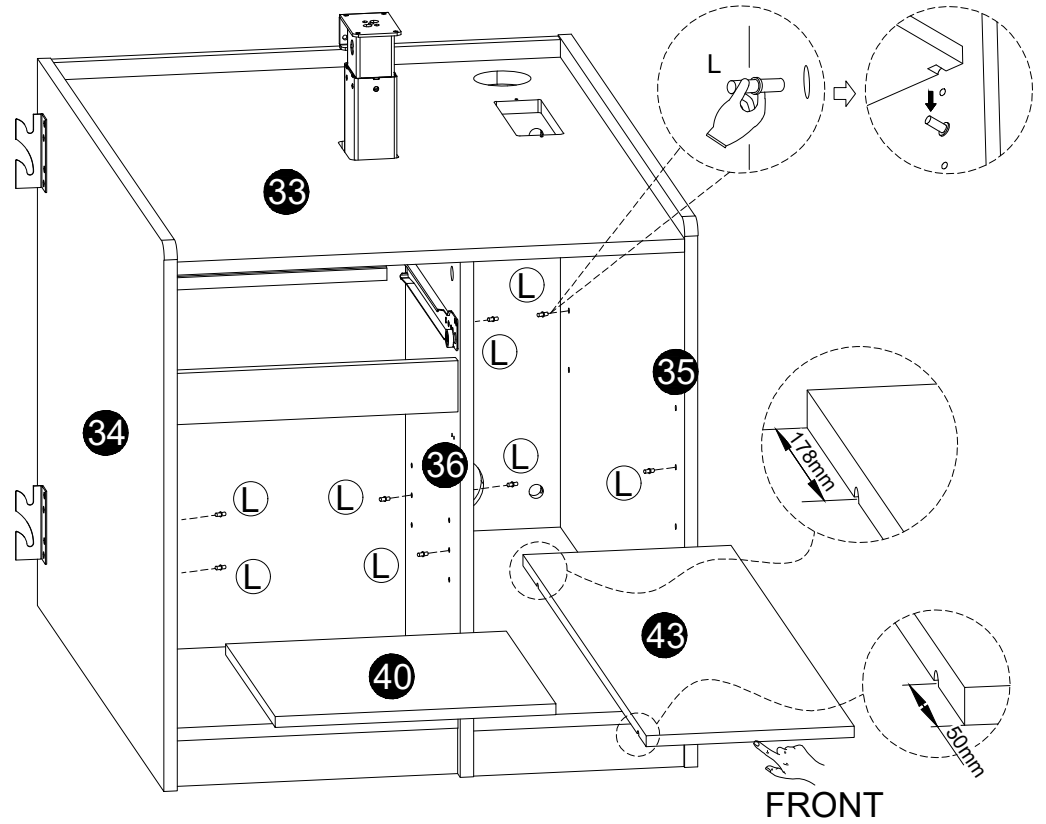

STEP 40

 **F** X12

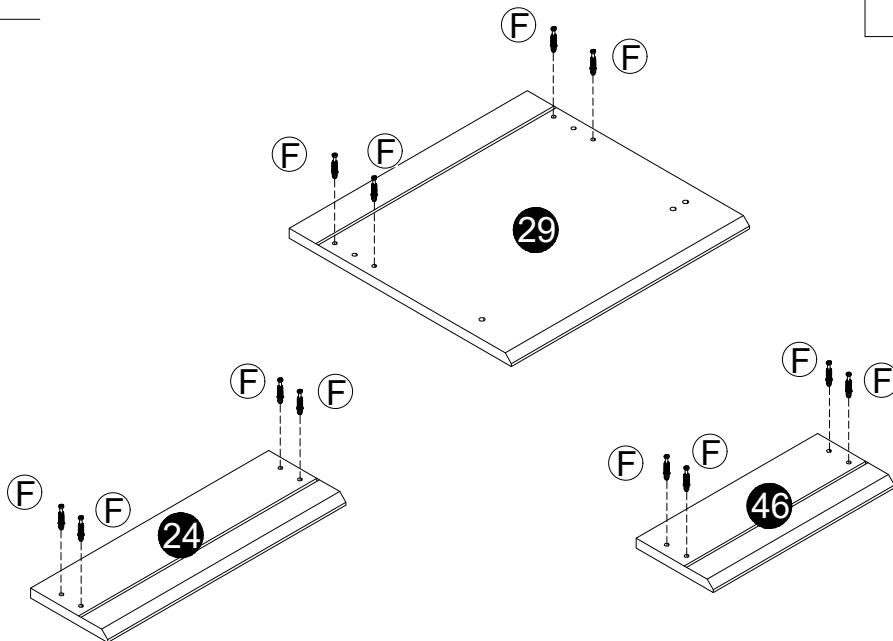
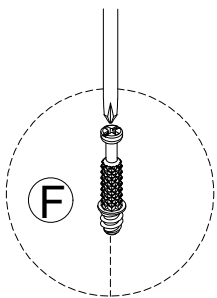
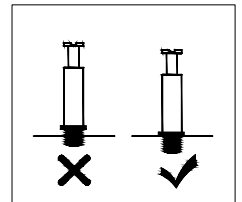

STEP 41

 **M** X8

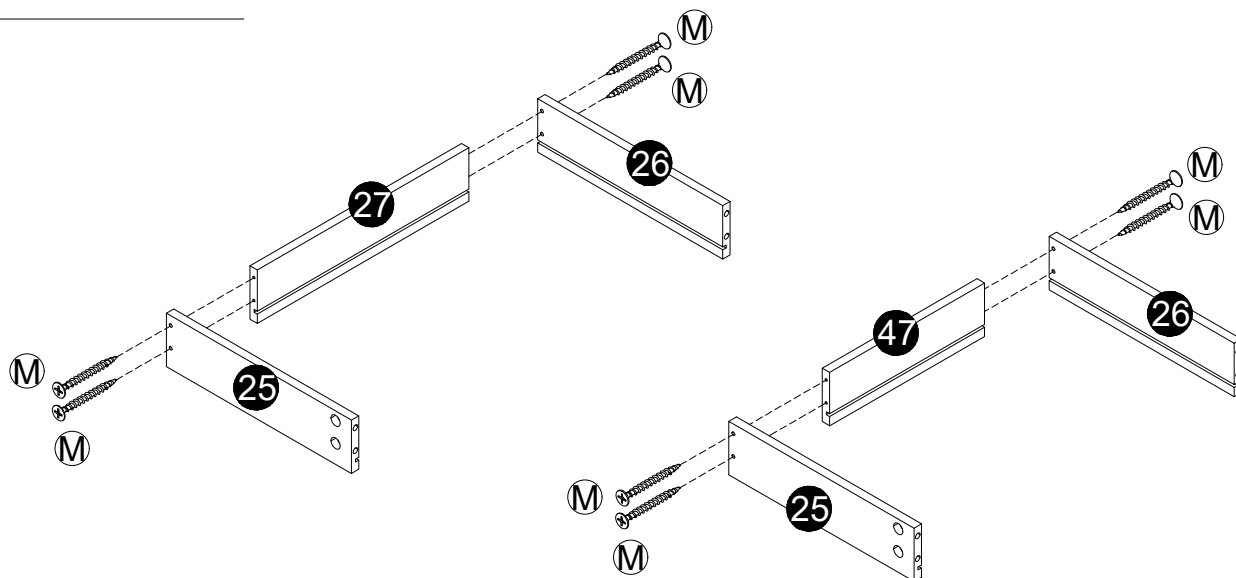

STEP 42

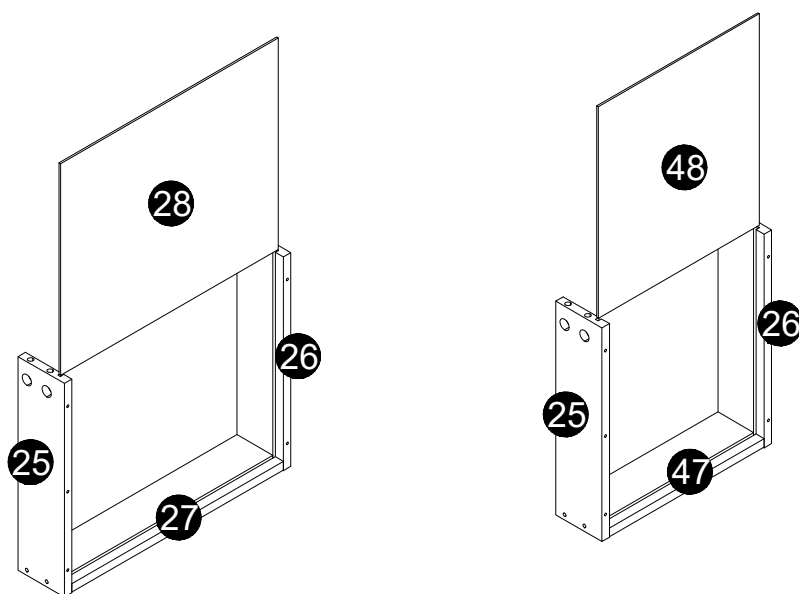

STEP 43



G X8

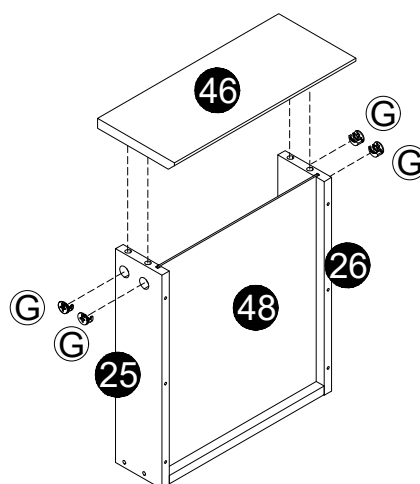
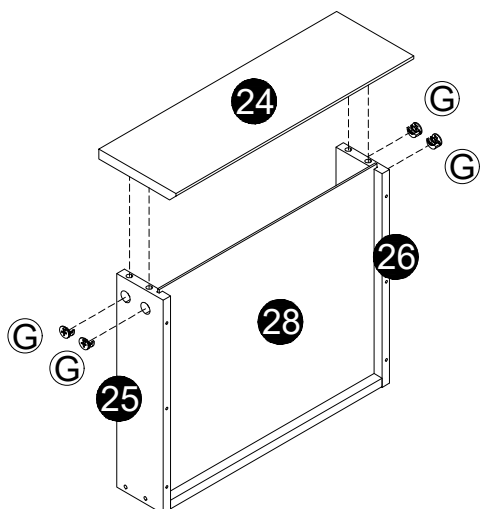
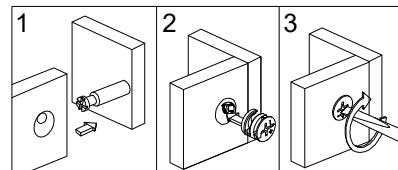

STEP 44

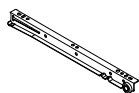

DL X2

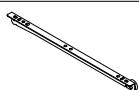

DR X2



J X12

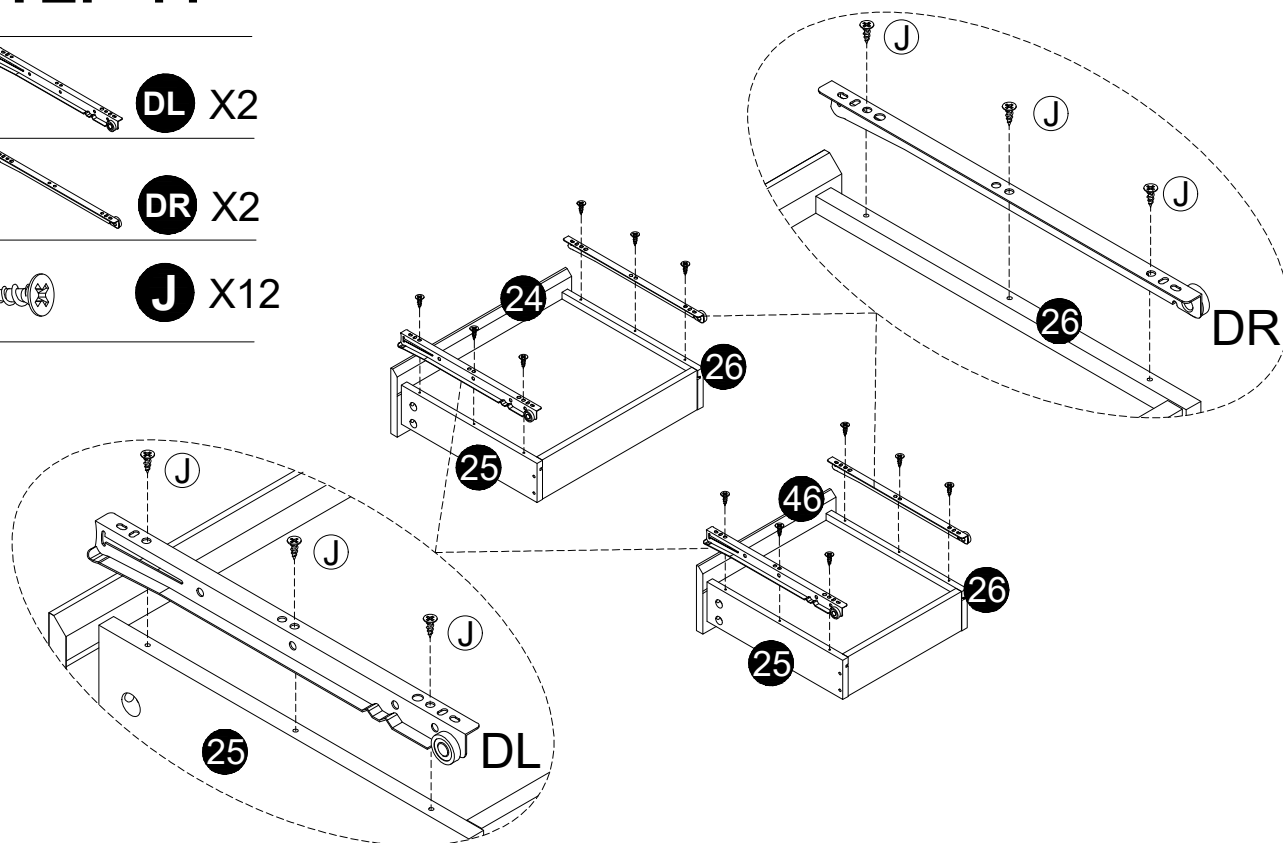

STEP 45



G X4



H X2

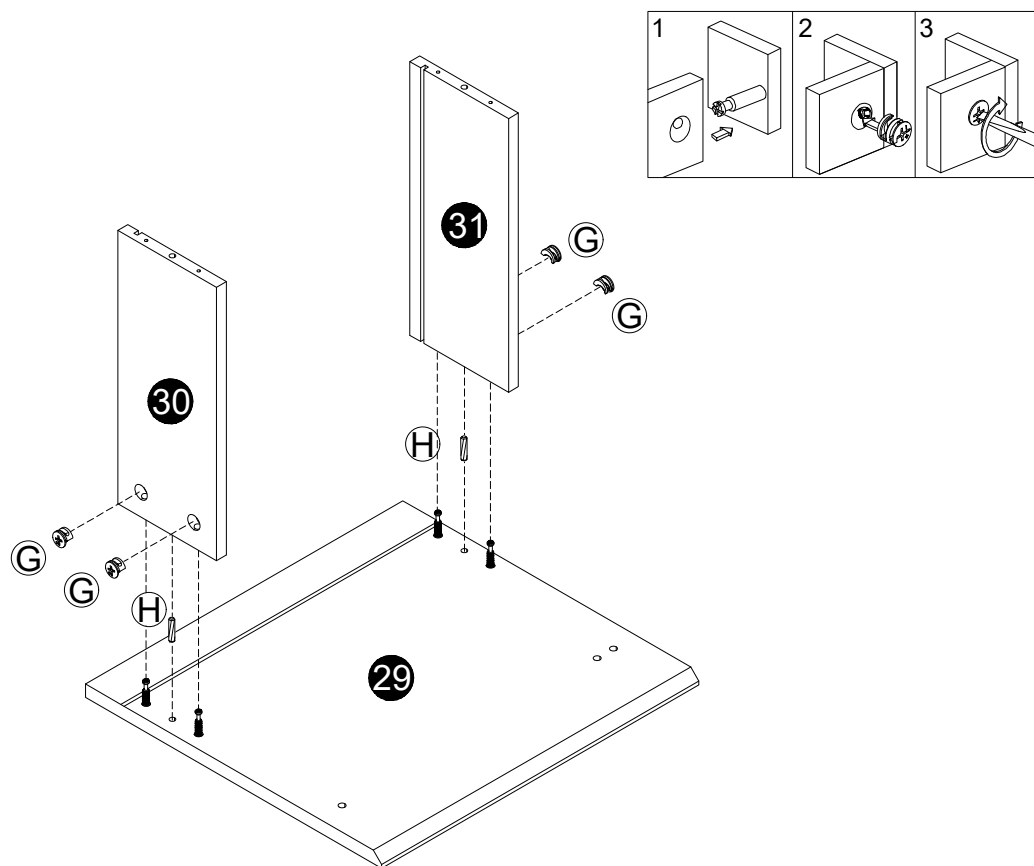

STEP 46

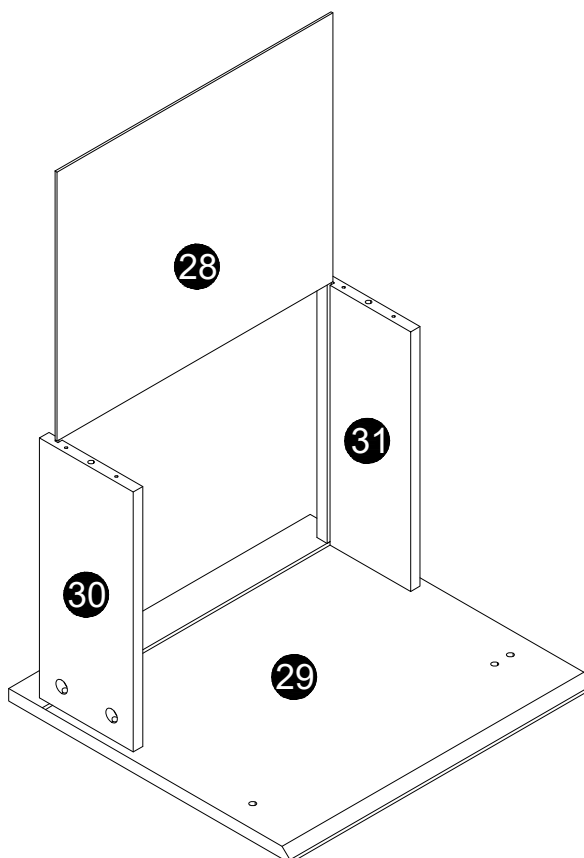

STEP 47

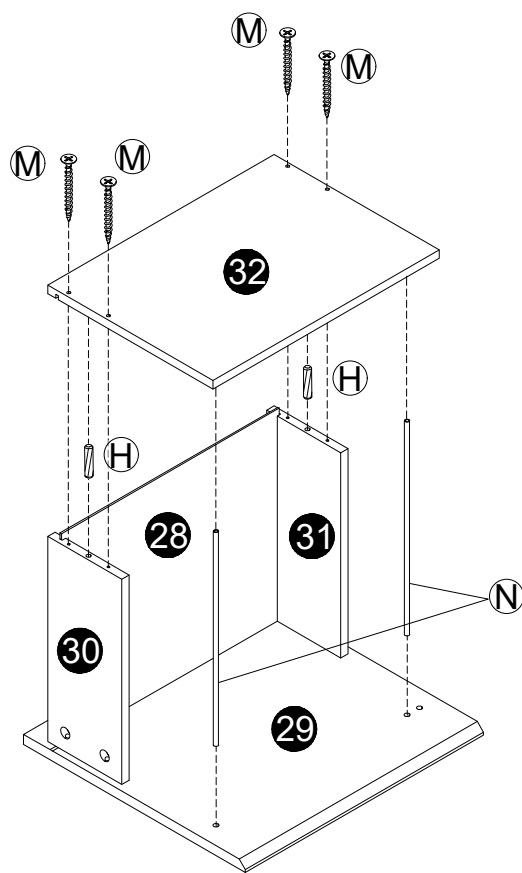
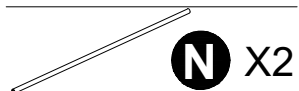

STEP 48

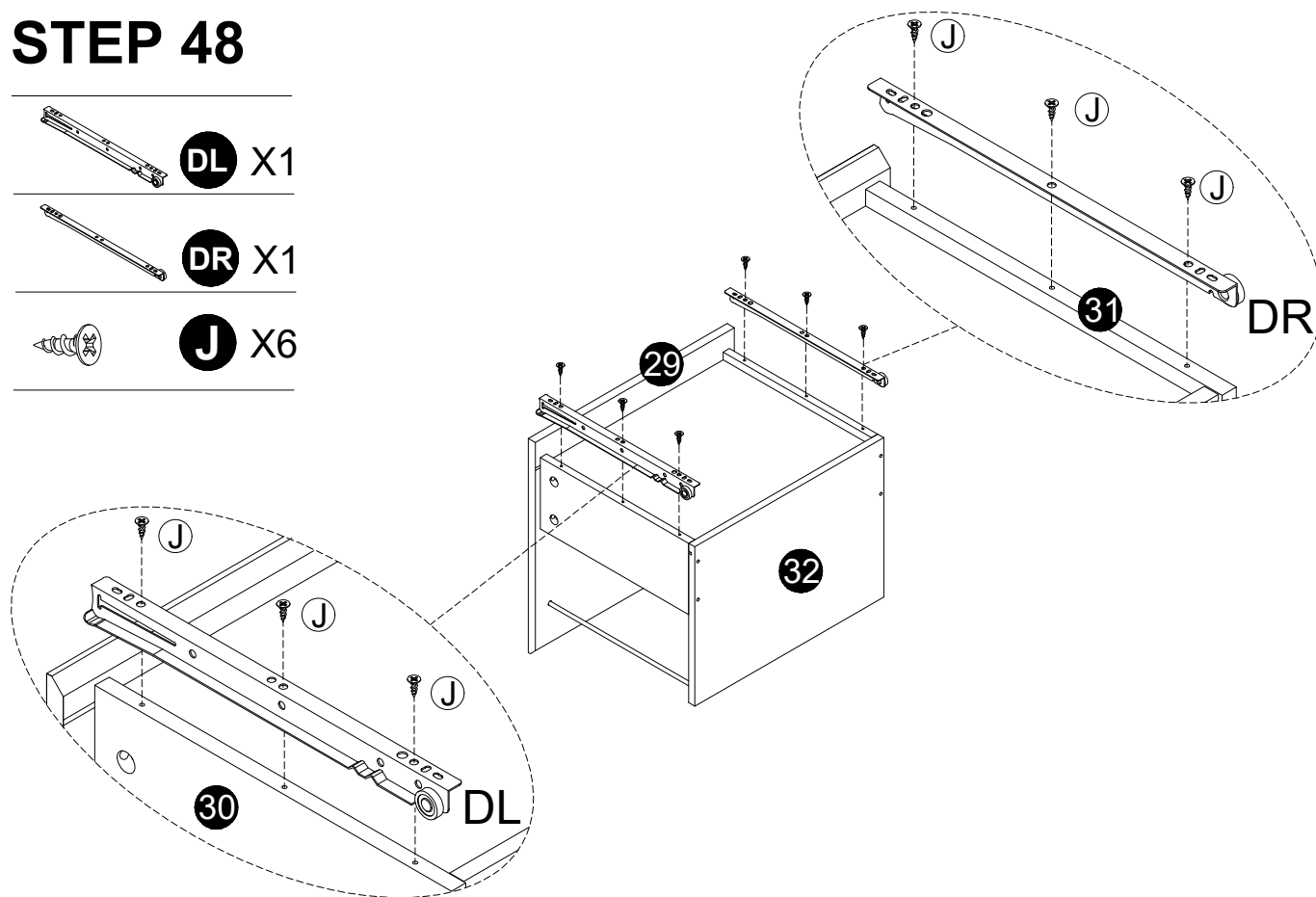
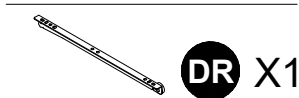
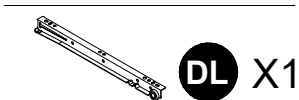

STEP 49

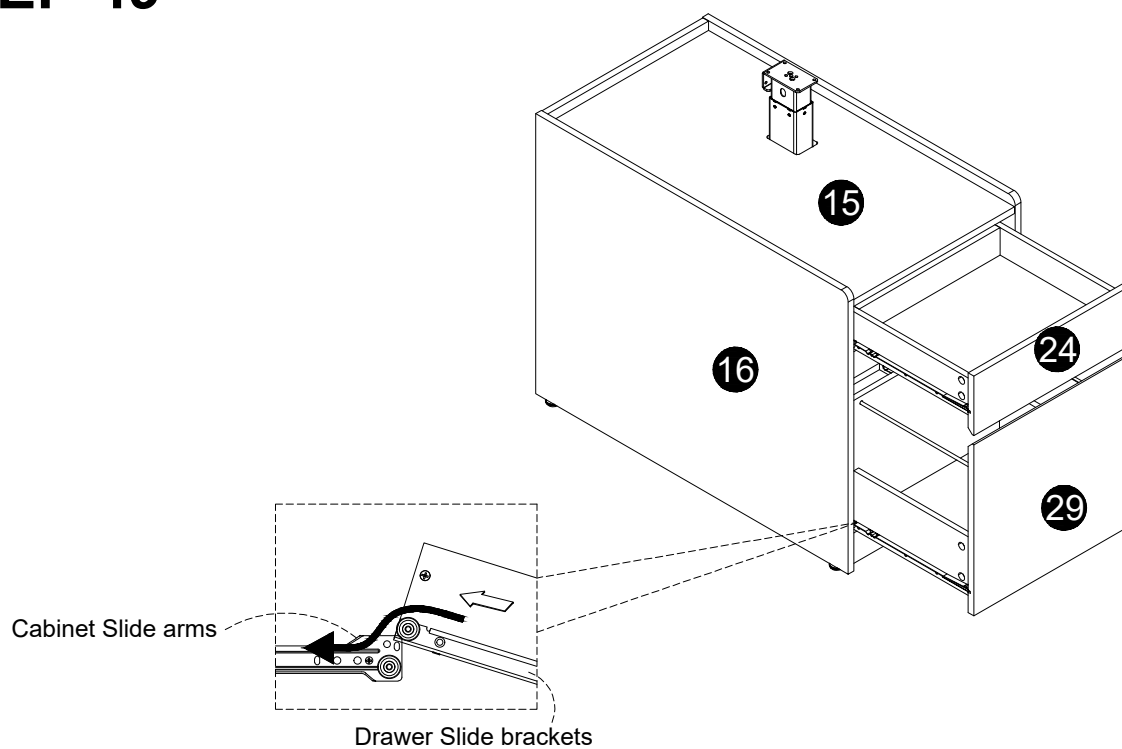

STEP 50

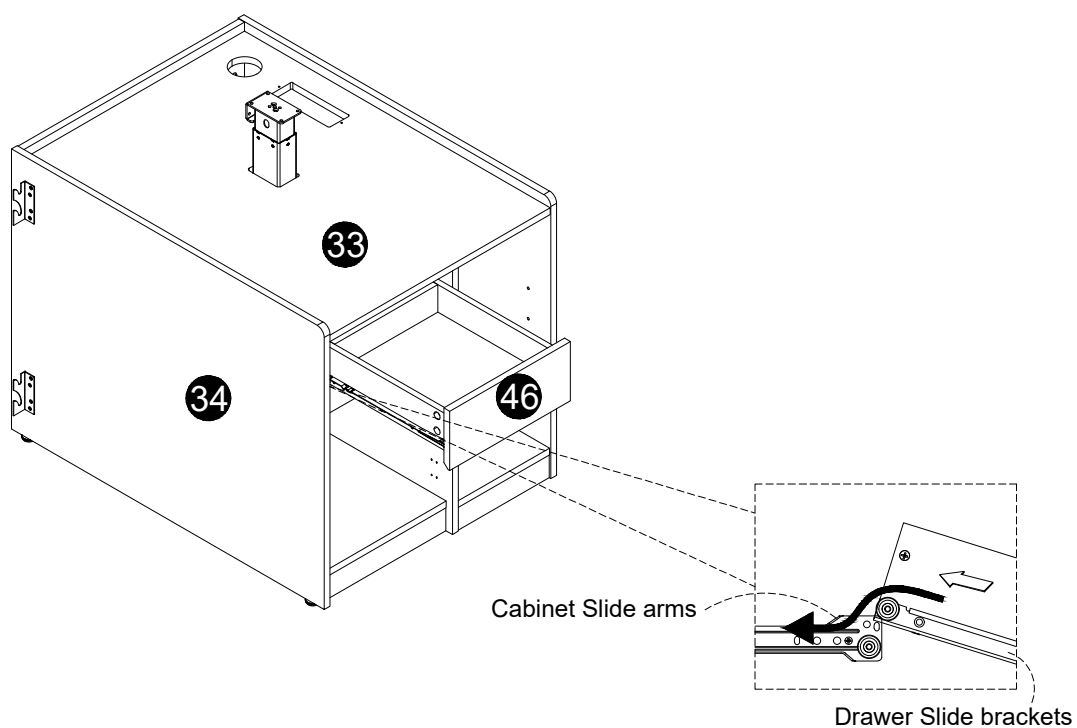

STEP 51

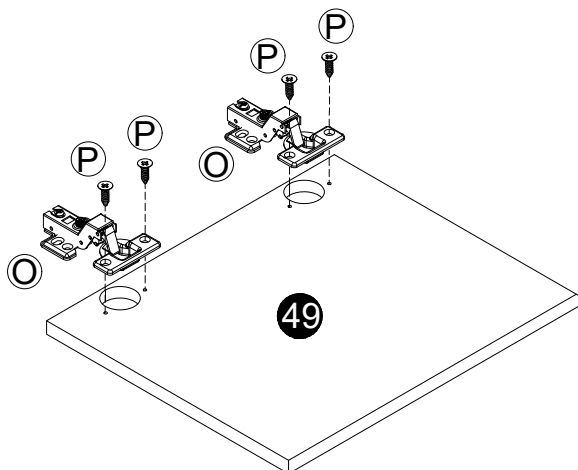

STEP 52

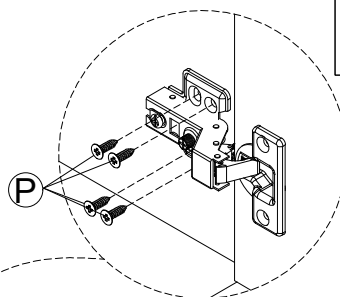
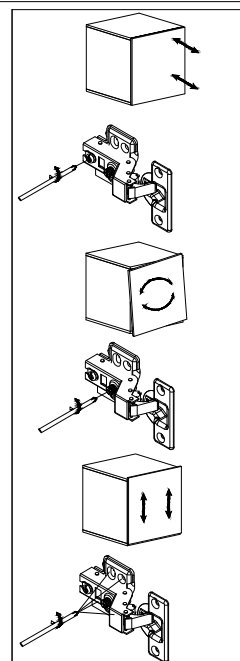
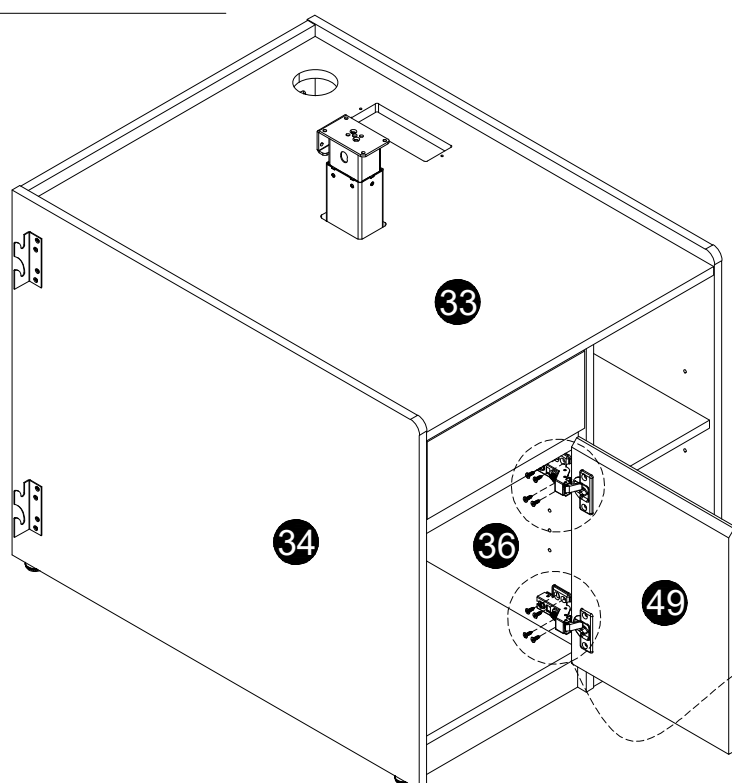

STEP 53

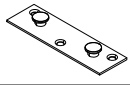

13 X4

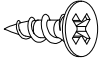

J X12

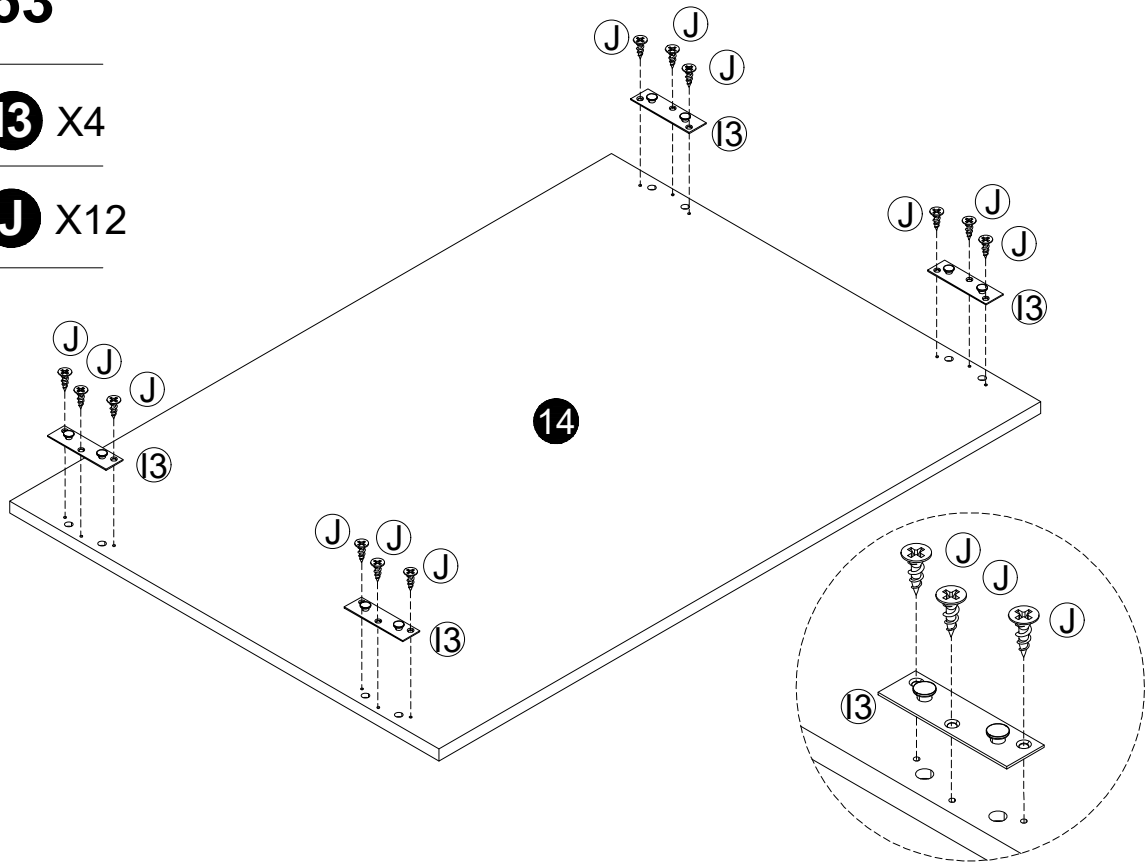

STEP 54

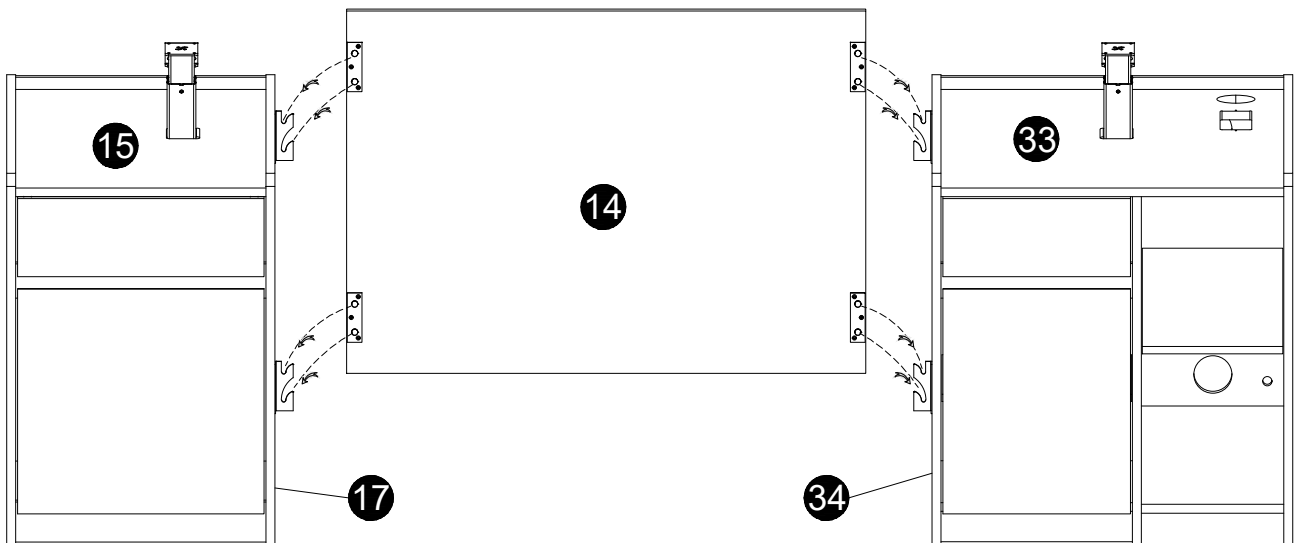

STEP 55 Before installing the columns, press them firmly into place or use the hex drive rod to adjust, ensuring that the column heights are consistent.

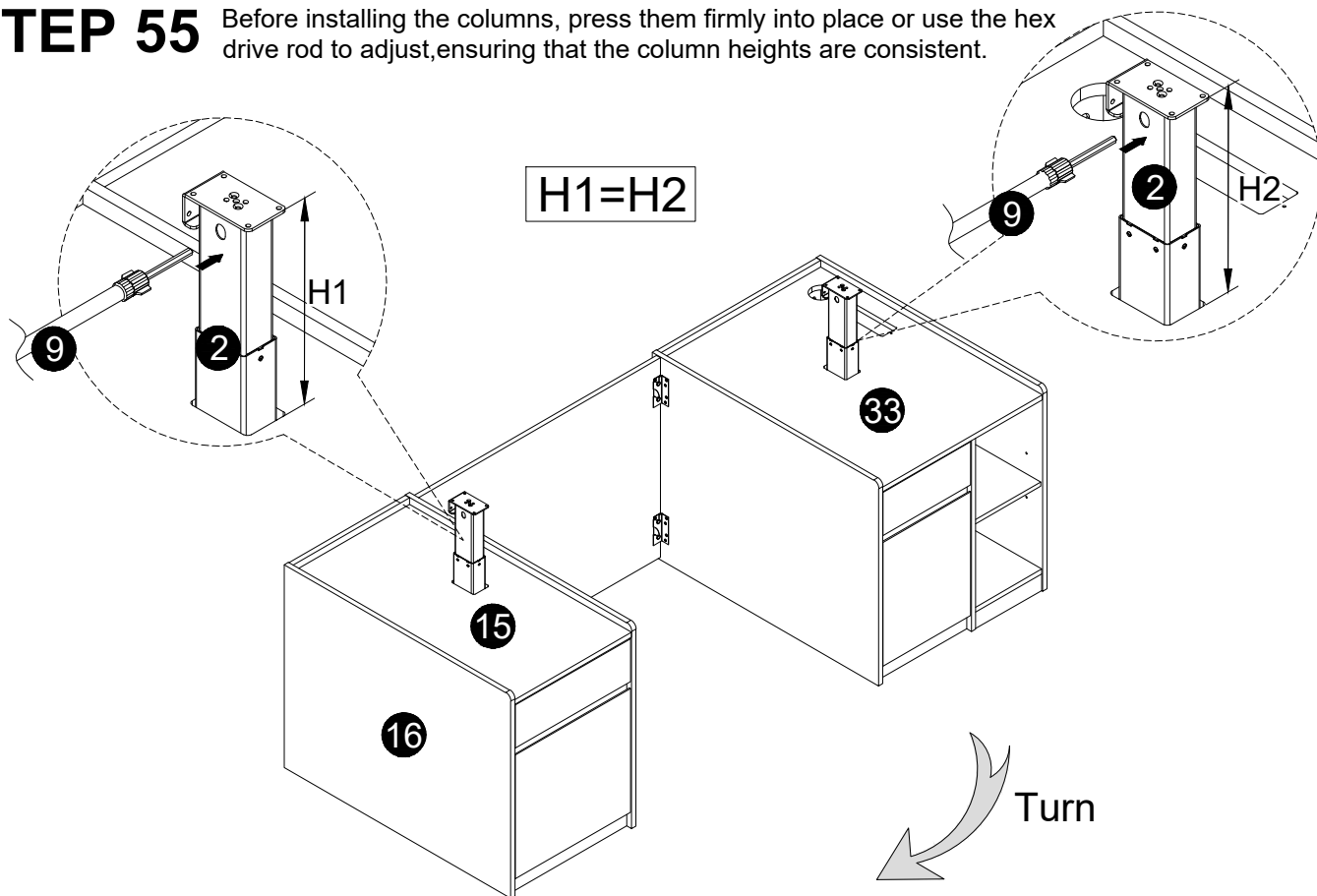

STEP 56

 **B** X4

 **C** X2

 **M4 T**

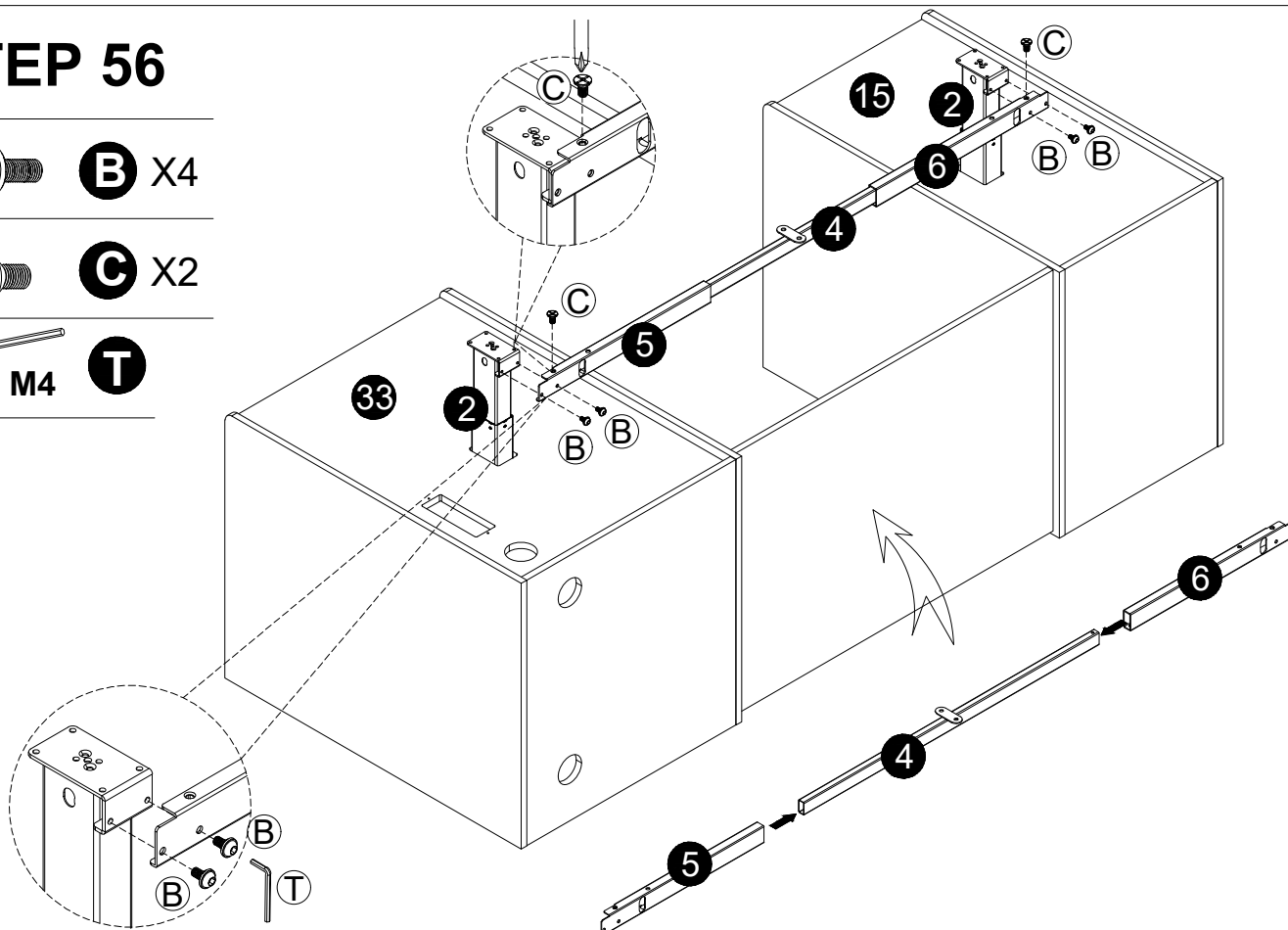

STEP 57

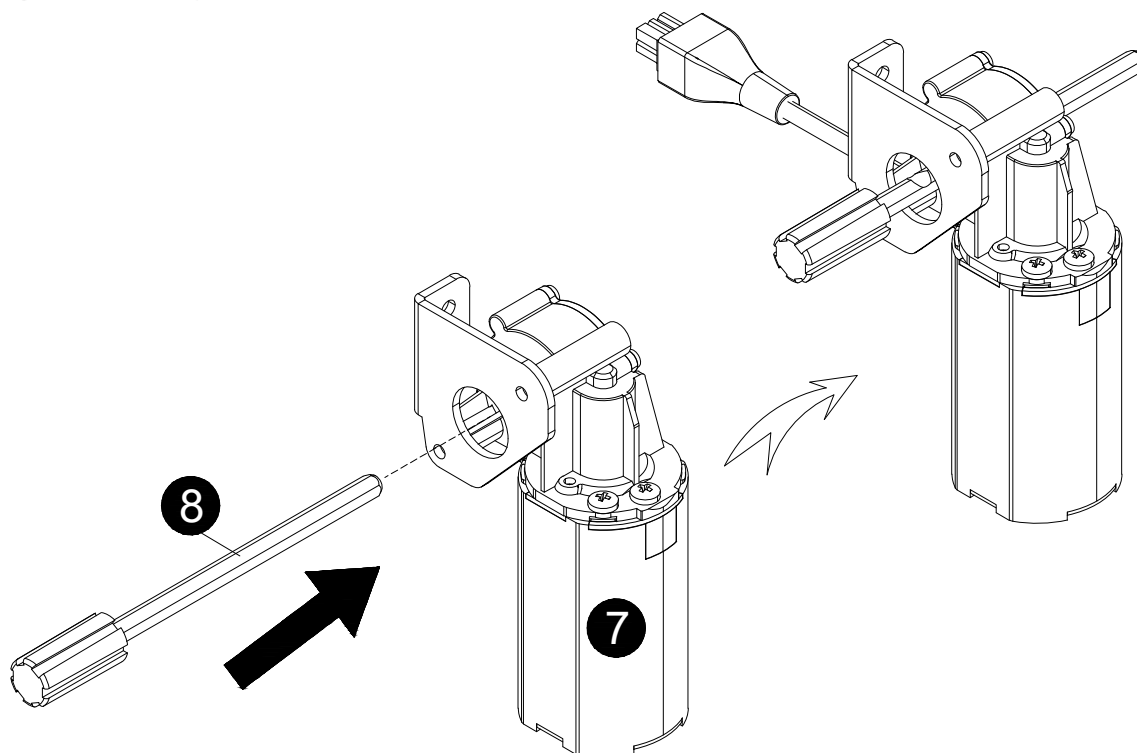

STEP 58

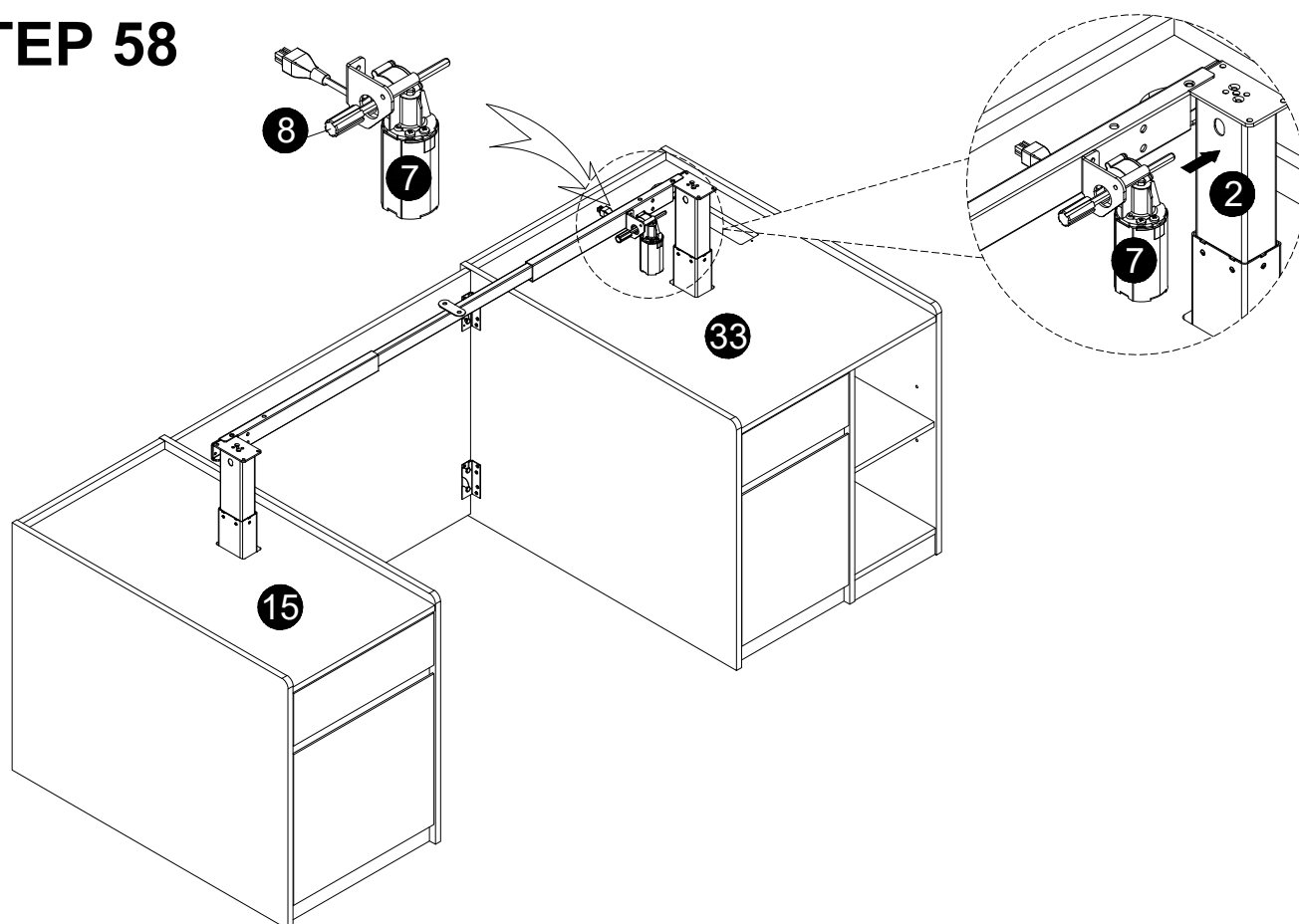

STEP 59

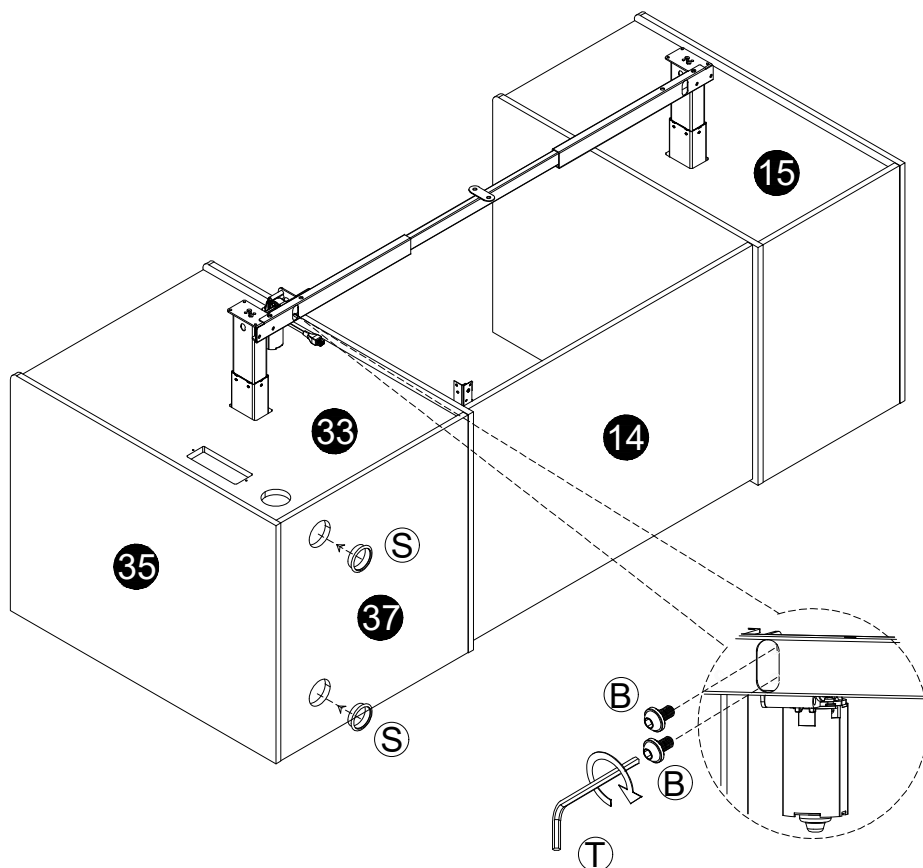

STEP 60

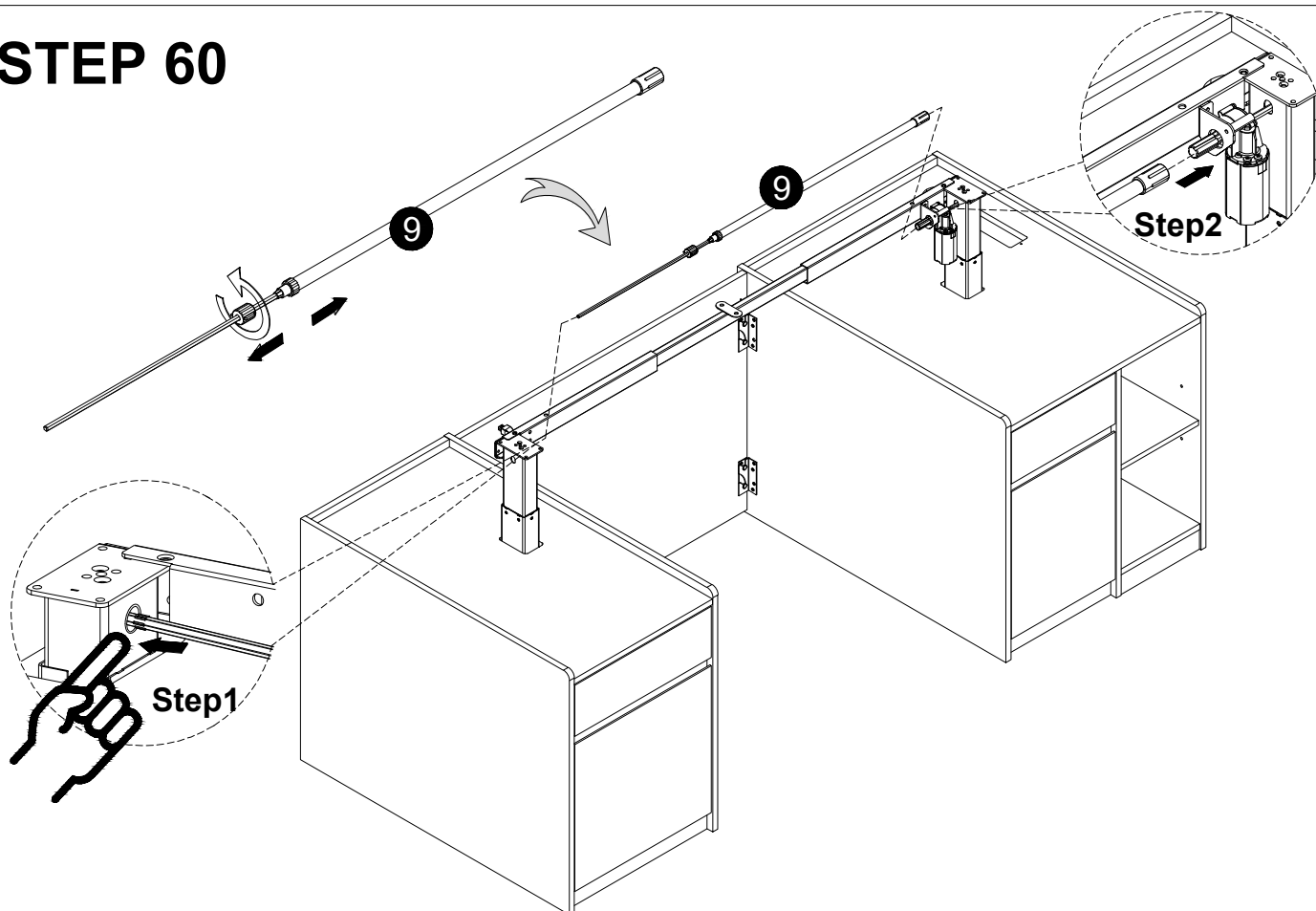

STEP 61



C X4

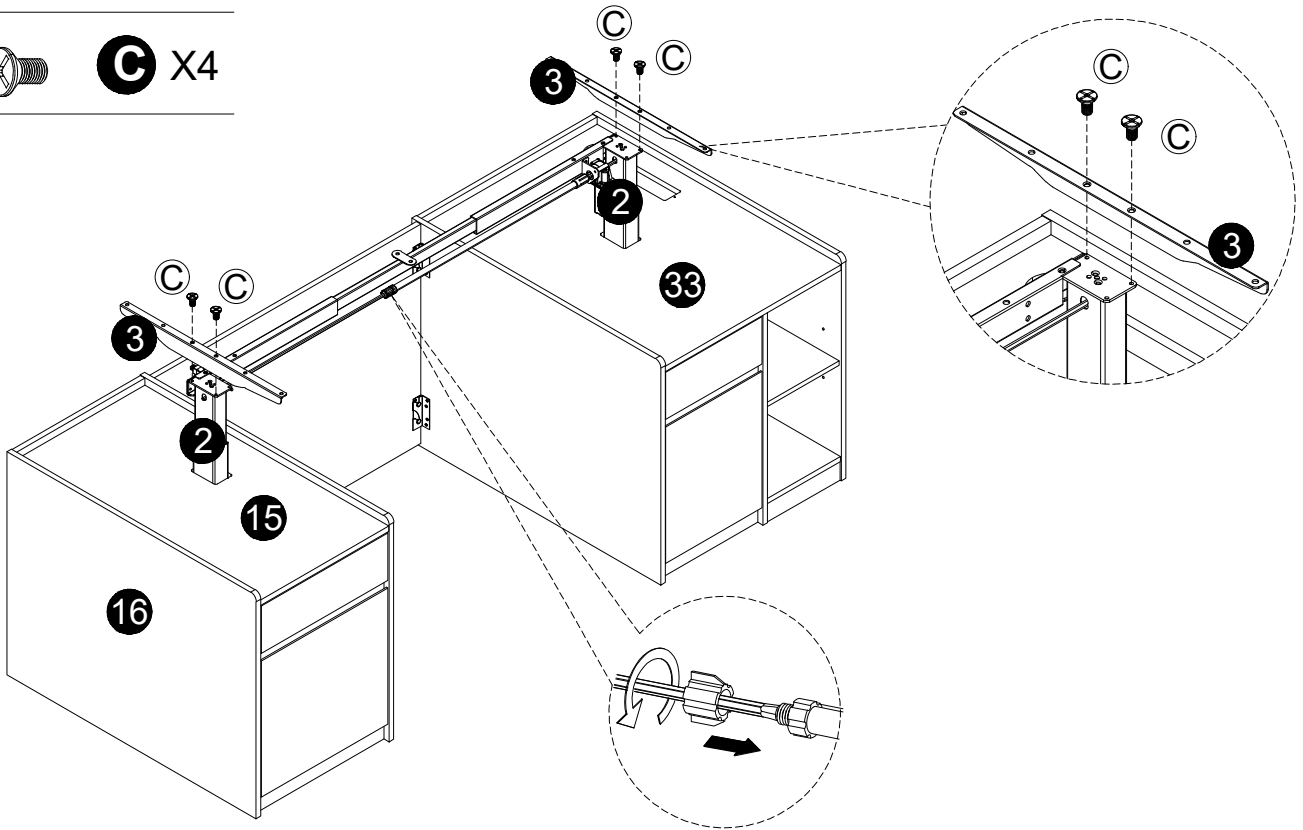

STEP 62

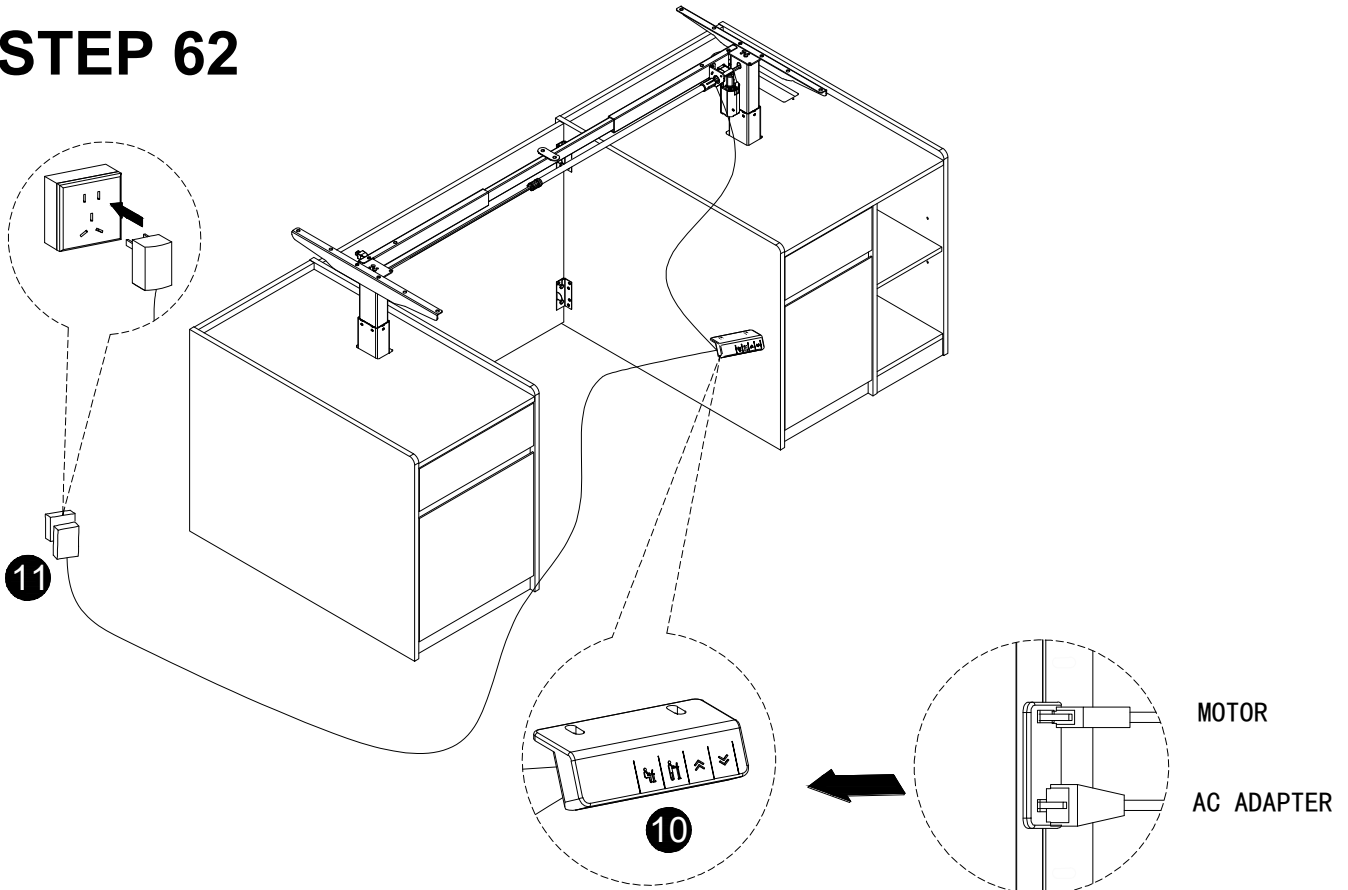

STEP 63

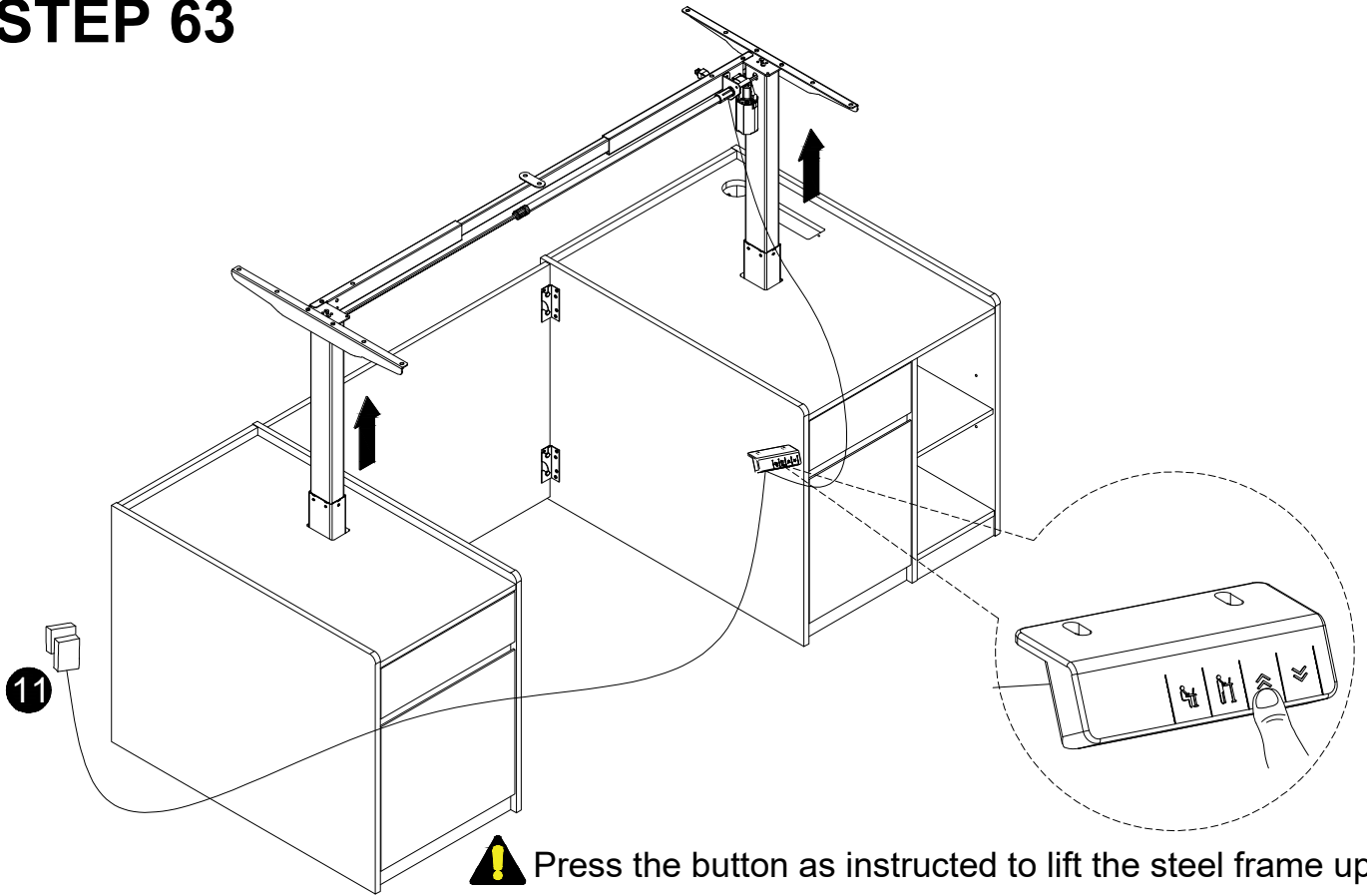

STEP 64

! Turn off the power before continuing the installation.

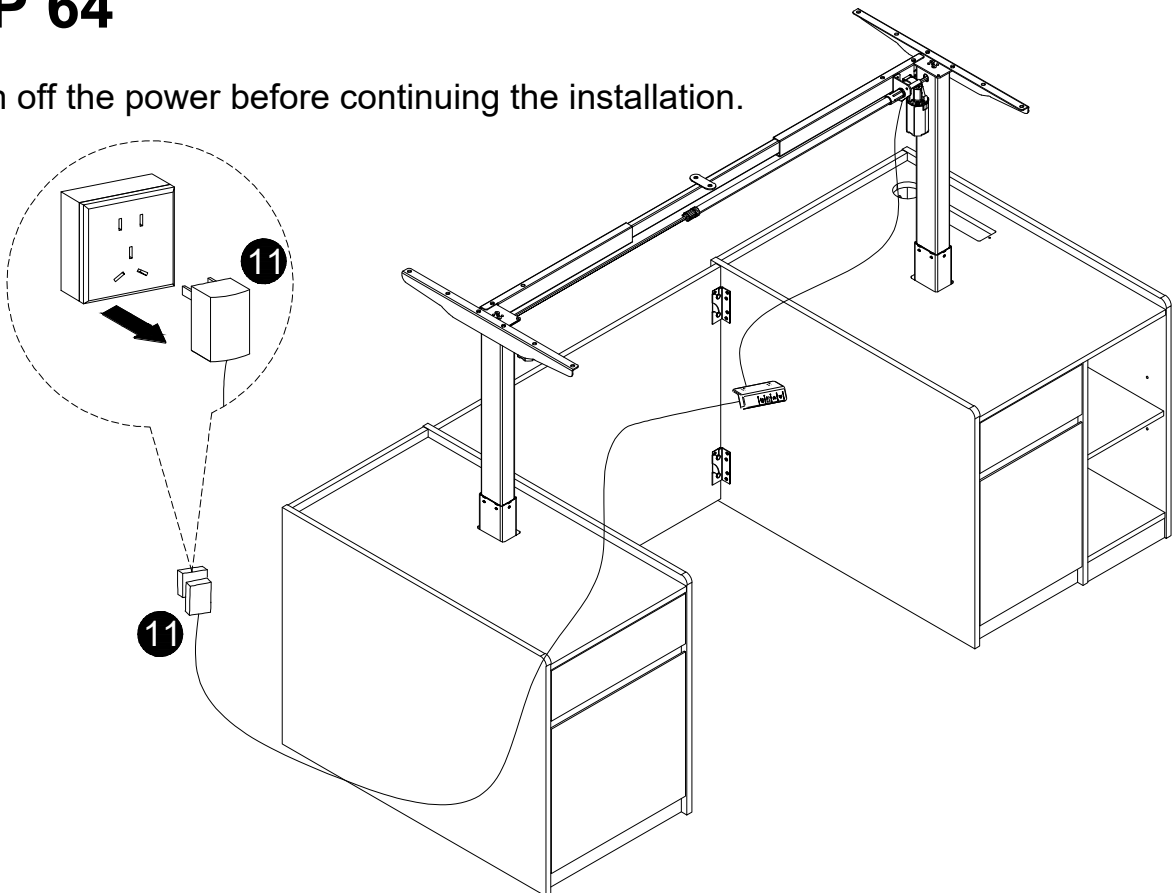

STEP 65



D X14

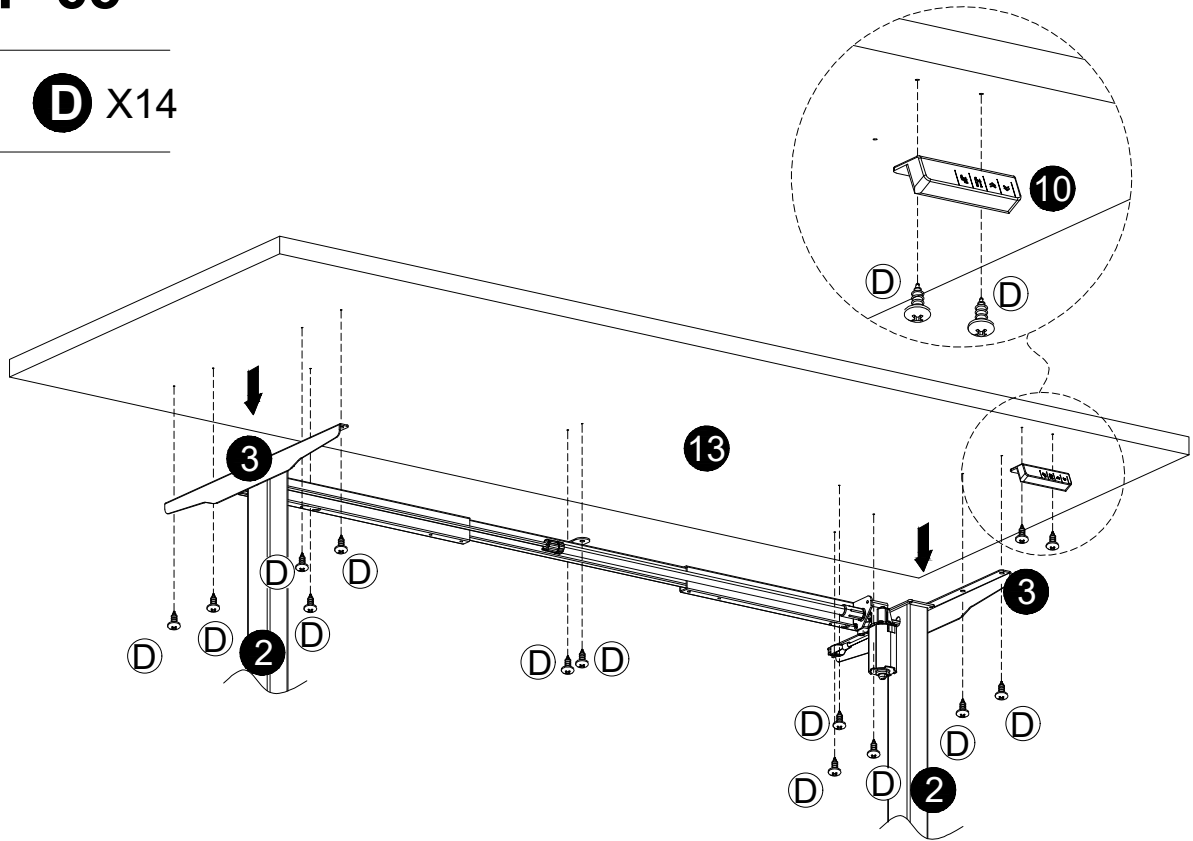

STEP 66



B X4

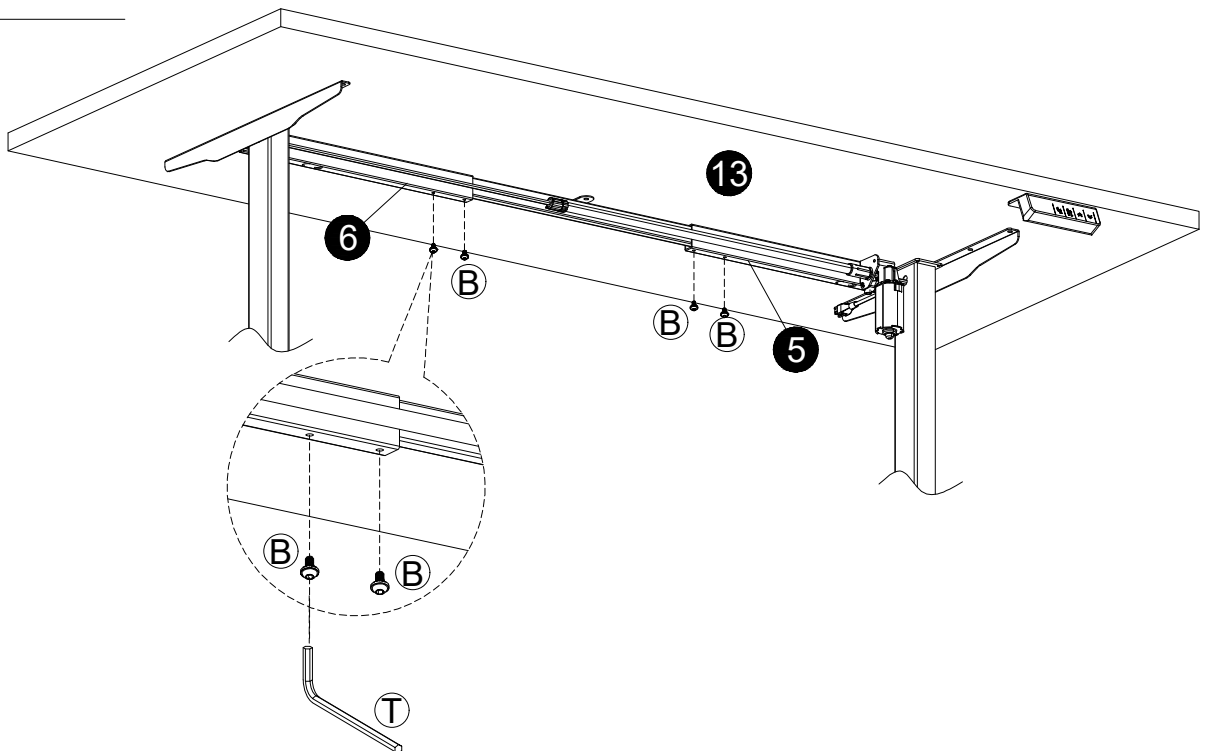

STEP 67

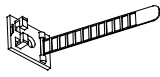
 **E** X3

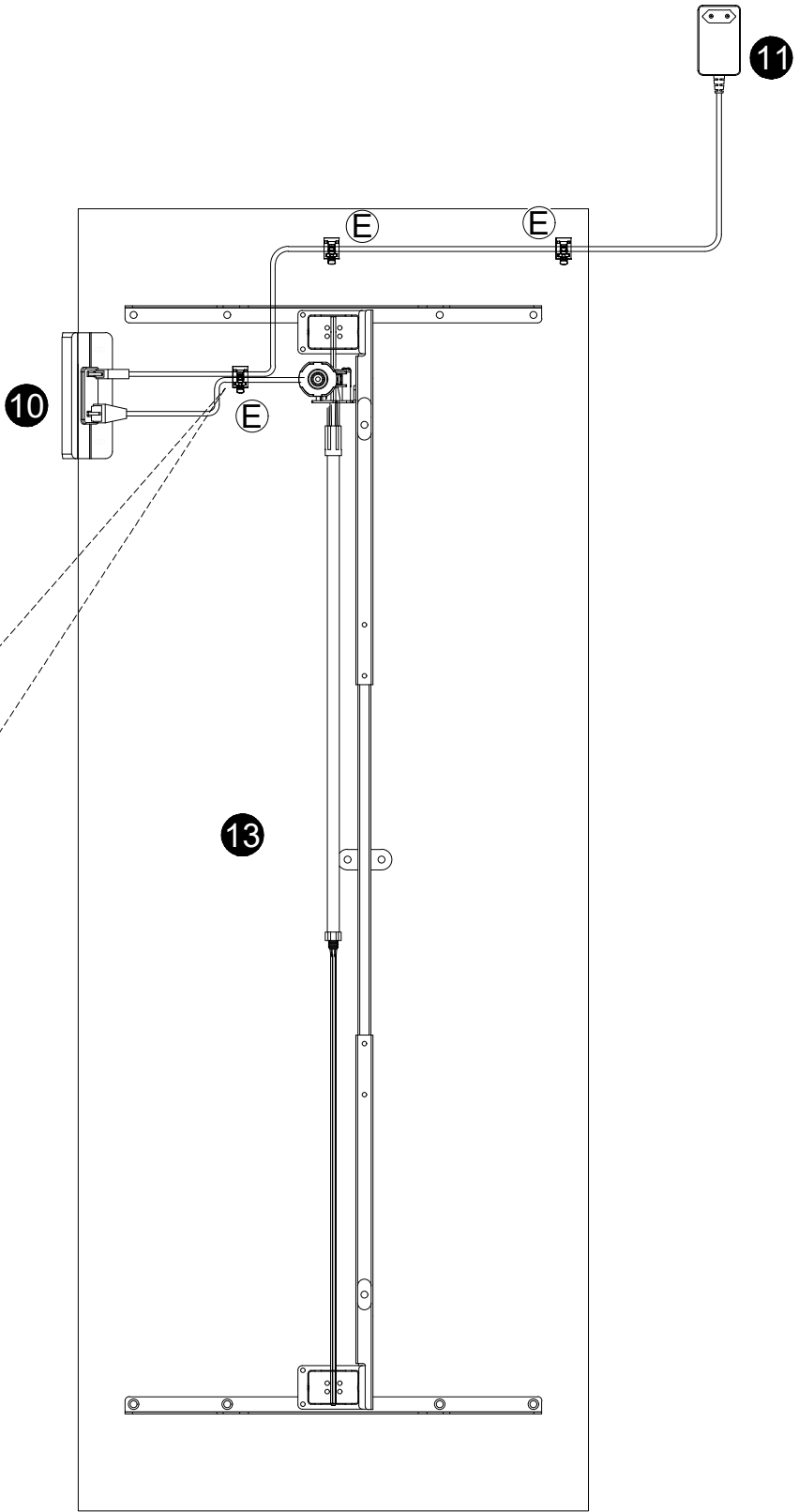
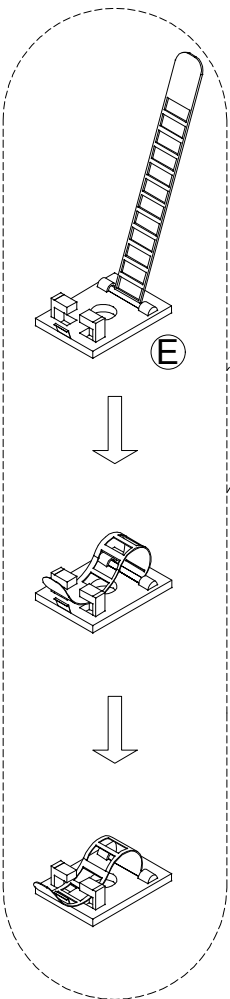

STEP 68



J X2

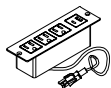

Q X1



R X1

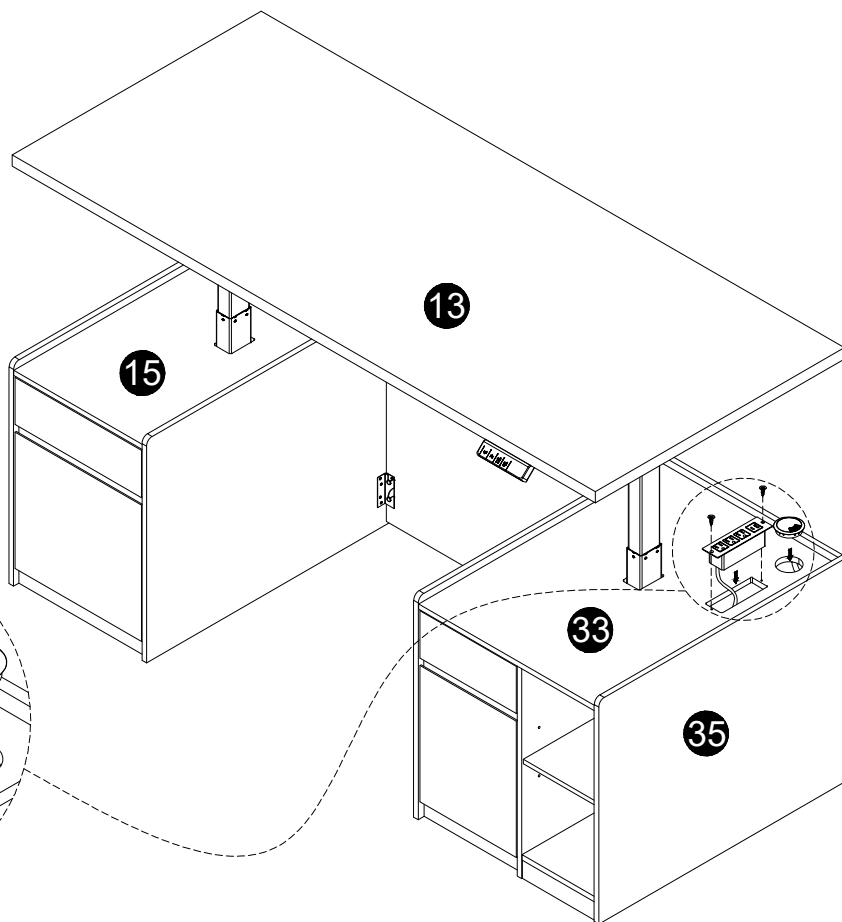
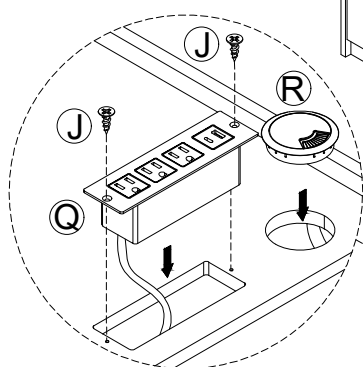

STEP 69

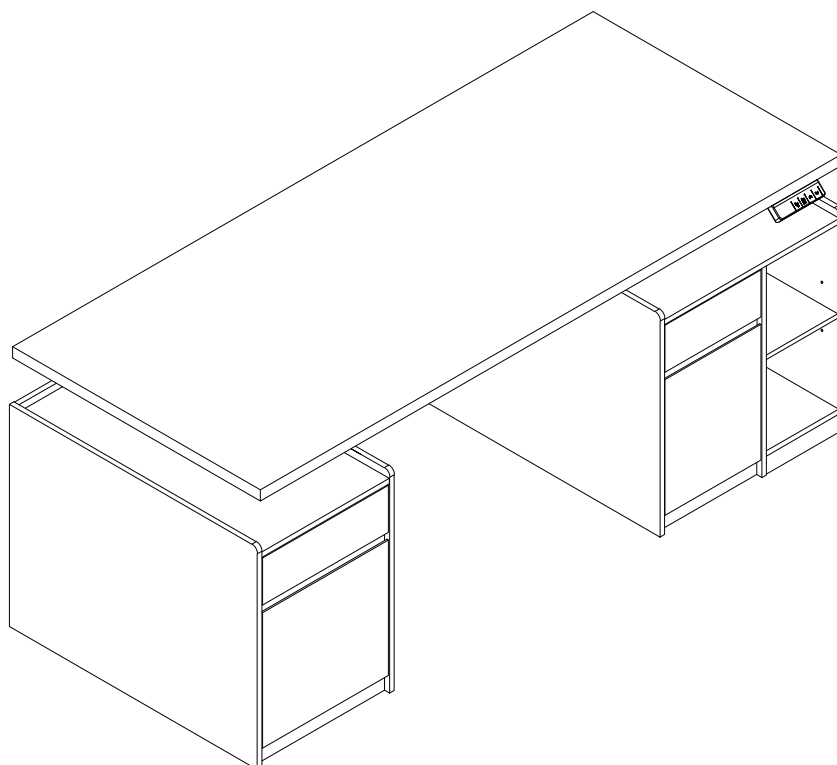

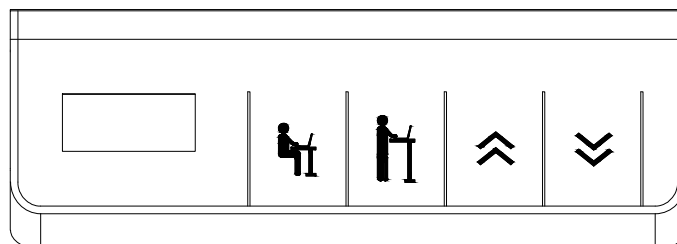

Using the Controller

Raise Desk	Press to raise the desk continuously until it reaches the highest position or the button is released.
Lower Desk	Press to lower the desk continuously until it reaches the lowest position or the button is released.
Save Current Height Setting	When the standing desk is stopped, press and hold the or key until the display shows 'S-1' or 'S-2'. The current height position will then be saved to the corresponding button.
Recall Height Setting	When the standing desk is stopped, short press or , the desk will move to the height that was previously set for that button. During the operation of standing desk, press any button to stop it.
Power-Saving Mode	The screen will turn off if there is no button-press during 1 minute. Any button-press will turn the screen on again.

Settings Menu

- **Change Display Height Units**



Simultaneously press and hold the and buttons for 8 seconds until the display screen is flashing. Then simultaneously briefly press the and buttons to switch the display to 'U-0'. Short press or to switch between 'U-1' (imperial) and 'U-0' (metric). Once the modification is complete, simultaneously press and hold the and buttons. When the screen displays 'SUS', it indicates that the settings have been successfully updated.

- **Change Collision Detection Sensitivity**

Simultaneously press and hold the and buttons for 8 seconds until the display screen is flashing. Then simultaneously briefly press the and buttons to switch the display to 'PC3' (up collision sensitivity) or 'DC4' (down collision sensitivity). Short press either the or button to adjust the collision protection sensitivity. After adjustment, simultaneously press and hold the and buttons until 'SUS' is displayed to complete the settings and exit.

Sensitivity Adjustment Range: 0=OFF; 1~5, the bigger the number, the higher the sensitivity

- **Reset**

Press and hold  until the desk stops moving for 5 seconds, the controller will display 'rSt', indicating the reset process has started. Keep holding the  button, the desk will slowly descend to its lowest position and then automatically rebound a short distance. Release the  button complete the reset operation. If any unexpected situation occurs during the reset process, you can release the button at any time to stop the desk movement and terminate the reset process. After termination, you will need to restart the reset operation until it is successfully completed before proceeding with any other operations.

Protection Mode Error Codes

Overheat Protection: HOT	Solution 1. Disconnect the power supply and wait for the screen to go off, and then power on again to use the desk. Solution 2. Suspend the operation and wait for at least 18 minutes before using it.
Overload Protection: E11	Remove heavy objects from the table and wait until the alarm is cleared before using standing desk.
Motor Abnormal Protection: E12	Power off, check and make sure the connection between the motor and the controller is normal, and then power on again to use the desk.
Motor Stall Alarm: E15	Seriously overloaded or the transmission mechanism is stuck. Remove the overloaded object and check whether there is any objects stuck in the transmission mechanism.
Motor Wire Not Connected: E16	Check the connection cable between the motor and the controller. It can be restored after reconnecting.