

ASSEMBLY INSTRUCTIONS

(CHAIR)

**NOTE: THIS ITEM NOT RECOMMENDED FOR COMMERCIAL USE
KEEP THIS DOCUMENT FOR REFERENCE IN CASE PARTS ARE NEEDED**

DO NOT TIGHTEN SCREWS UNTIL COMPLETELY ASSEMBLED!!

PARTS LIST		QTY'
A	Chair Back	1pc
B	Seat	1pc
C	Front Leg	2pcs

HARDWARE LIST		QTY'
1	Bolt $\varnothing 1/4"$ x 20 x 2-3/8"	4pcs
2	Spring Washer $\varnothing 5/16"$ x 1/2" x 1/16"	10pcs
3	Flat Washer $\varnothing 5/16"$ x 3/4" x 1/16"	10pcs
4	Bolt $\varnothing 1/4"$ x 20 x 1-1/2"	2pcs
5	Bolt $\varnothing 1/4"$ x 20 x 3-1/8"	4pcs
6	Allen Key 5/32"	1pc

STEP 1

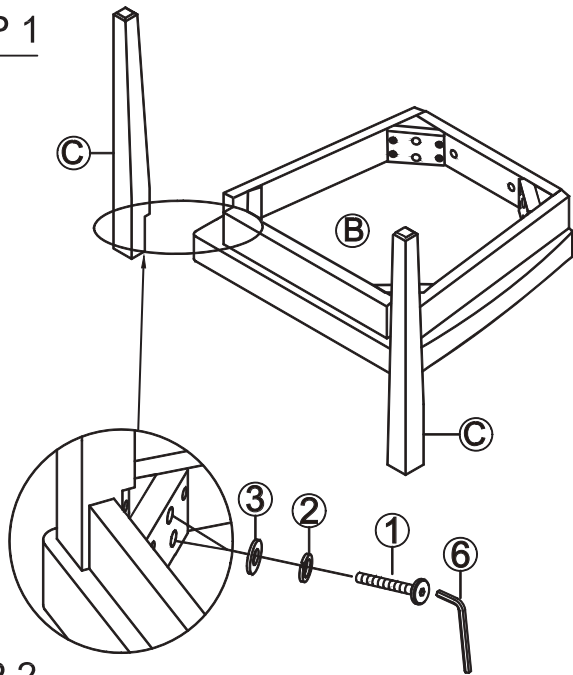

STEP 2

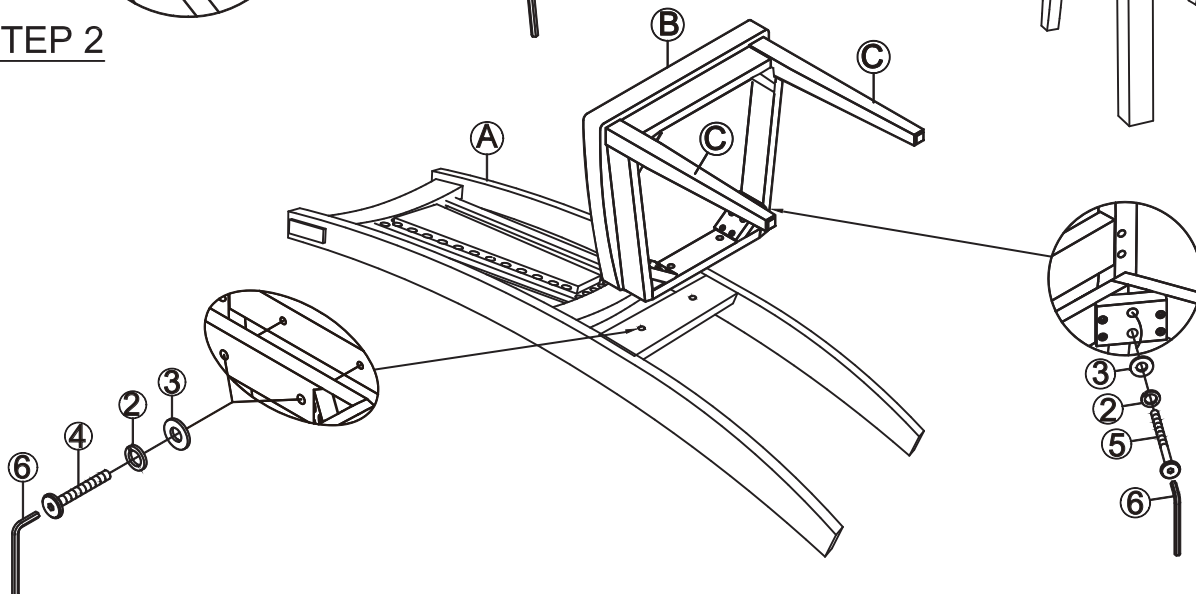



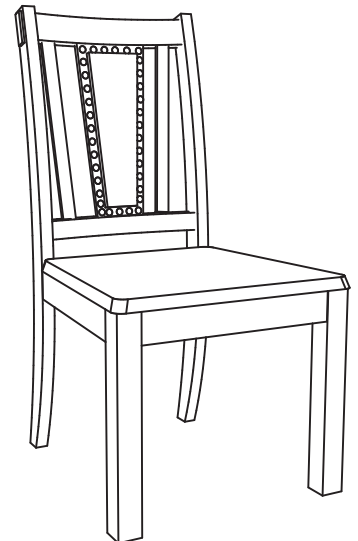

ASSEMBLY COMPLETED



ASSEMBLY INSTRUCTIONS

(TABLE)

**NOTE: THIS ITEM NOT RECOMMENDED FOR COMMERCIAL USE
KEEP THIS DOCUMENT FOR REFERENCE IN CASE PARTS ARE NEEDED
DO NOT TIGHTEN SCREWS UNTIL COMPLETELY ASSEMBLED!!**

HARDWARE LIST			QTY'
1	Bolt $\varnothing 5/16"$ x 20 x 2-3/8"		8pcs
2	Spring Washer $\varnothing 5/16"$ x 1/2" x 1/16"		8pcs
3	Flat Washer $\varnothing 5/16"$ x 3/4" x 1/16"		8pcs
4	Allen Key 5/32"		1pc

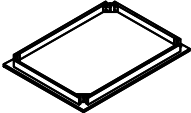
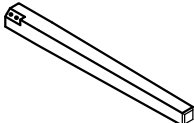
PART LIST			QTY'
A	TABLE TOP		1 PC
B	TABLE LEG		4 PCS

ASSEMBLY COMPLETED

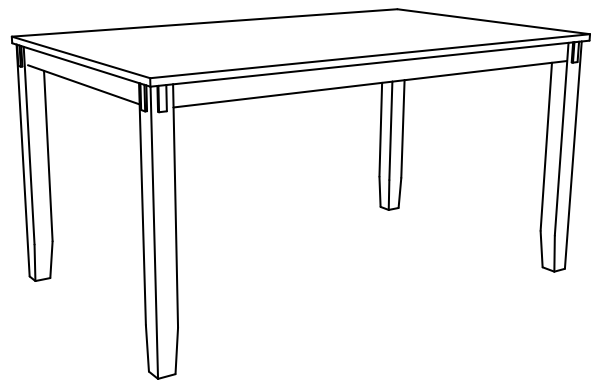

STEP 1

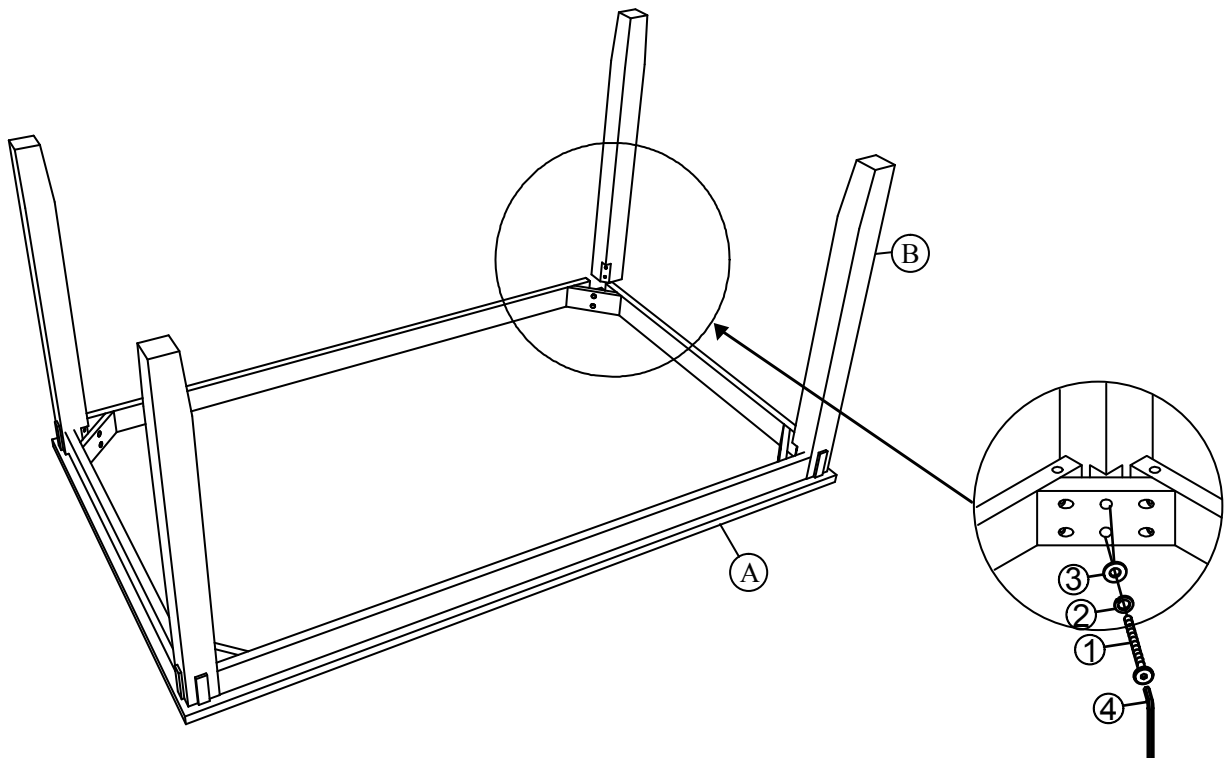







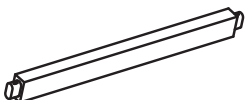

ASSEMBLY INSTRUCTIONS

(BENCH)

**NOTE: THIS ITEM NOT RECOMMENDED FOR COMMERCIAL USE
KEEP THIS DOCUMENT FOR REFERENCE IN CASE PARTS ARE NEEDED**

DO NOT TIGHTEN SCREWS UNTIL COMPLETELY ASSEMBLED!!

PARTS LIST			QTY'
A	Seat		1pc
B	Short Stretcher		2pc
C	Long Stretcher		1pc
R/L	Leg (Left/Right)		4pcs

HARDWARE LIST			QTY'
1	Bolt $\varnothing 1/4"$ x 20 x 2-3/8"		8pcs
2	Spring Washer $\varnothing 5/16"$ x 1/2" x 1/16"		8pcs
3	Flat Washer $\varnothing 5/16"$ x 3/4" x 1/16"		8pcs
4	Screw $\varnothing 8$ x $\varnothing 4$ x 1-3/4"		6pcs
5	Allen Key 5/32"		1pc

STEP 1

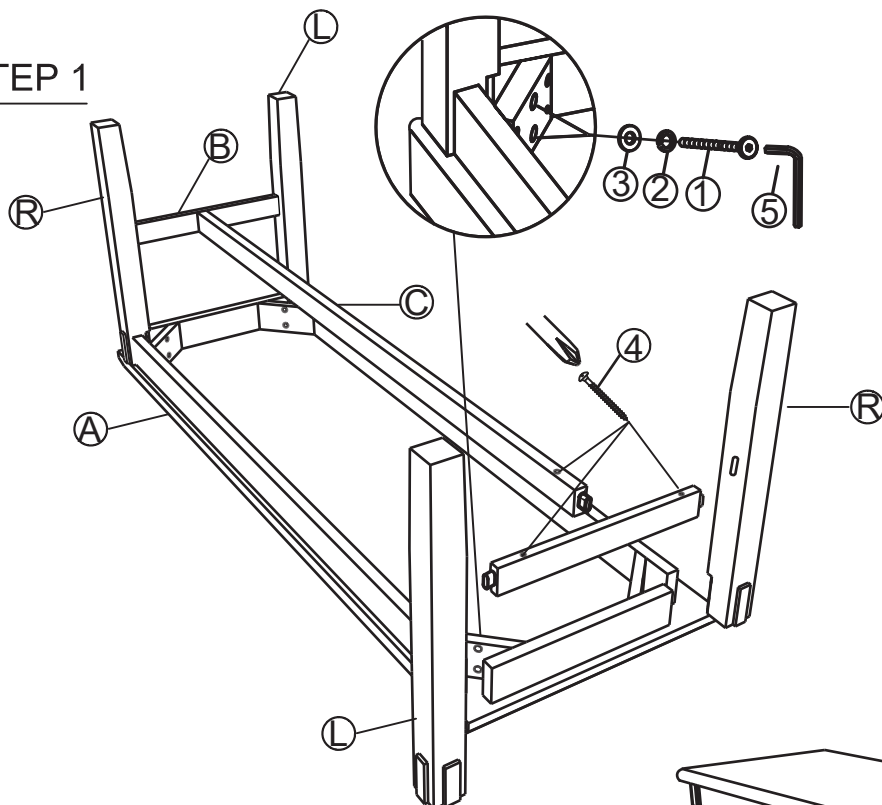

ASSEMBLY COMPLETED

