

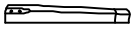





Do not tighten screws until completely assembled

## Parts

| NO. | Picture   | Description | Side QTY                         | QTY |
|-----|---|-------------|----------------------------------|-----|
| A   |  | FRONT LEG   | 40*40*410mm                      | 2   |
| B   |  | REAR LEG    | 40*30*410mm                      | 2   |
| C   |  | CHAIR BODY  | 20.5"W<br>*<br>27"D<br>*<br>25"H | 1   |

## Hardware

| NO. | Picture  | Description   | Side QTY   | QTY |
|-----|--|---------------|------------|-----|
| D   |  | Allen Key     | Ø5/16*65mm | 1   |
| E   |  | Bolt          | Ø5/16*50mm | 8   |
| F   |  | Flat Washer   | Ø5/16*22mm | 8   |
| G   |  | Spring Washer | Ø5/16*12mm | 8   |

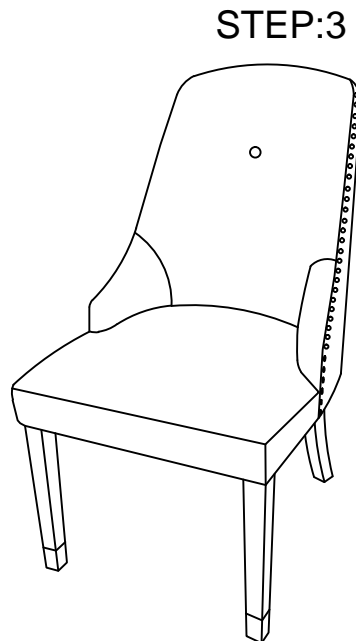
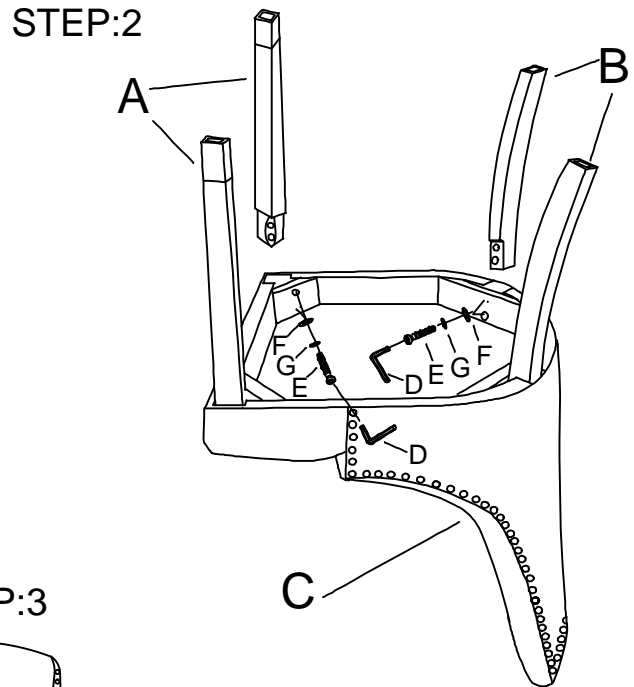
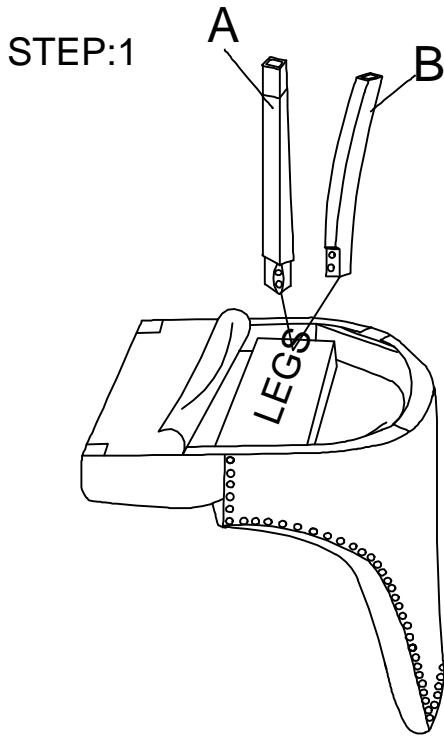

Overall Size: 20.5"W\*27"D\*38.5"H

Do not tighten screws until completely assembled