

Installation Manual

Any question please contact us:
support@jubest.com

MY2P-32x80P+HD

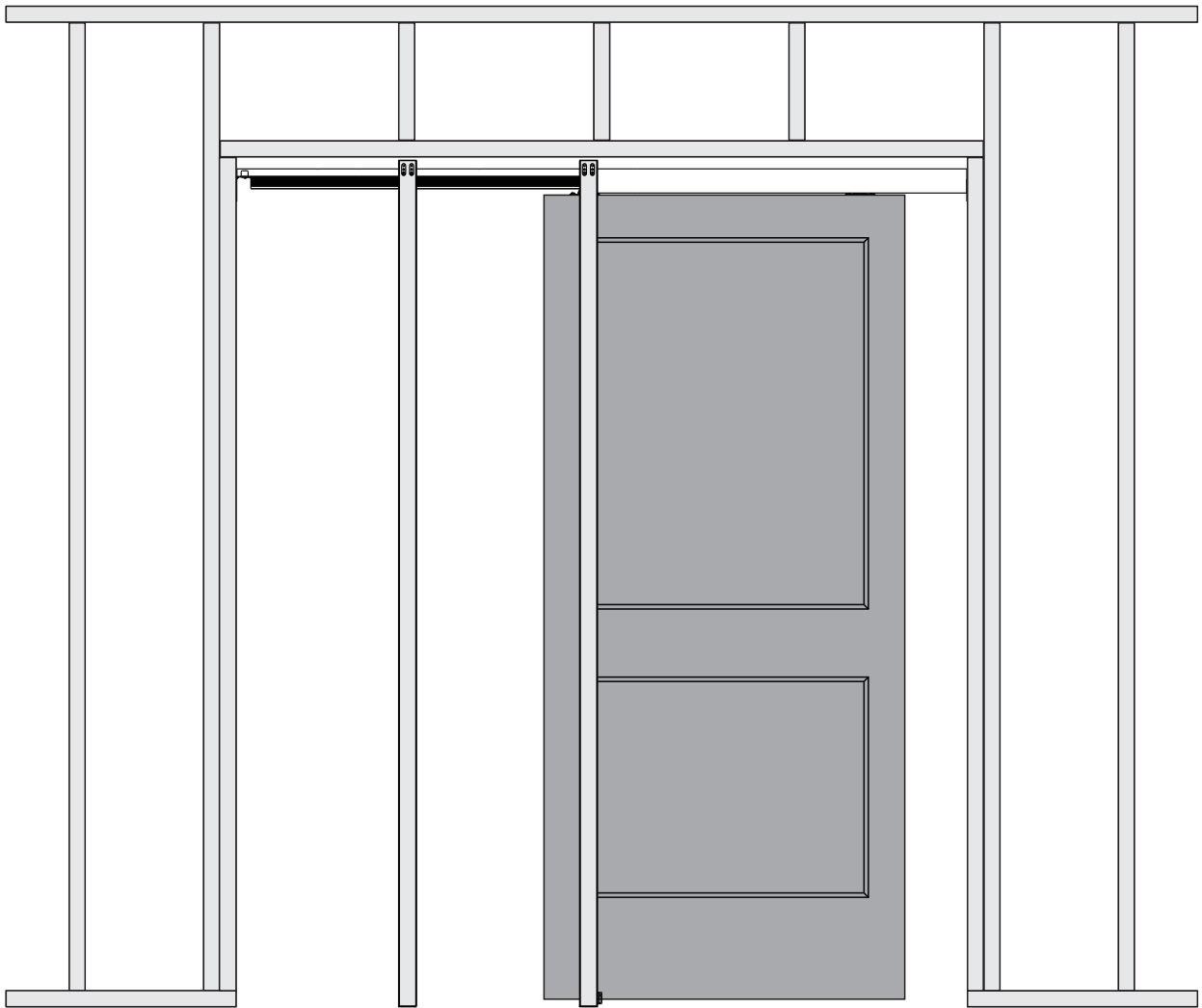





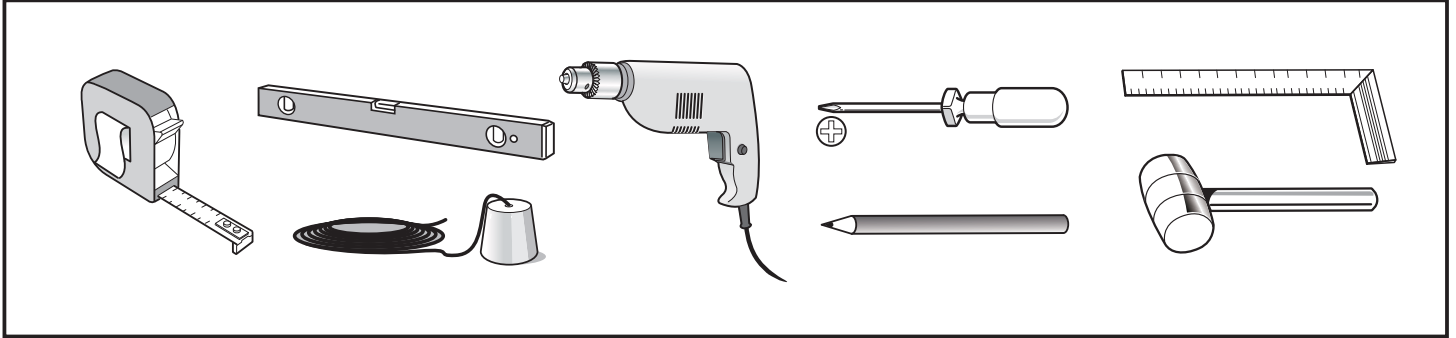



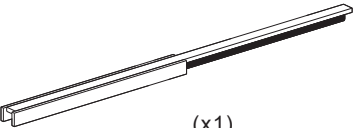
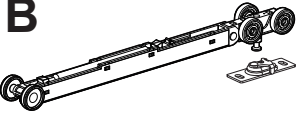
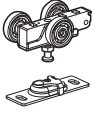

Pre-installation

TOOLS REQUIRED

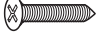

WHAT IS IN THE BOX

A  (x1)	B  (x1) #12 x 1-1/4" ST5.5x32 (x2)	C  (x1) #12 x 1-1/4" ST5.5x32 (x2)
D  (x1) #8 x 3/4" ST4.2x19 (x3)	E  (x1) #8 x 3/4" ST4.2x19 (x1)	F  (x2)
G  (x4) #8 x 3/4" ST4.2x19 (x8)	H  (x2)	I  (x2) #8 x 33/64" ST4.2x13 (x2)
J  32x80" door slab	 #6 x 1-1/4" ST3.5x32 (x3)	 (x1)
 (x1)		

PREPARE THE ROUGH OPENING

Height of Rough Opening (Table 1)

Nominal Door Height	Minimum Height of Rough Opening	Bracket Fastener Height from finished floor	Bracket Fastener Height from sub-floor
80"	84-1/2"	80-3/4"	81-1/2"

Width of Rough Opening (Table 2)

Nominal Door Width	Width of Rough Opening
24"	49"
30"	61"
32"	65"
36"	73"
Custom	(2 X Door Width) + 1"

Installation

For 1"(25mm) to 1-3/4"(45mm)
doors to 220 lbs.(100 kgs)

1 PREPARE ROUGH OPENING

Plumb the rough studs and ensure the header is square and level.
Minimum Height of ROUGH OPENING = 84-1/2"(2146mm)
Width of ROUGH OPENING = 65"(1651mm)

Measure up from finished floor **80-3/4"(2051mm)** or from sub-floor to **81-1/2"(2070mm)**. This will give 3/4"(19mm) to 1-1/2"(38mm) clearance under door. Mark each rough stud and drive hat head nail on center, (not included) leaving 1/8"(3mm) protruding. (Frame header end brackets will rest on these screws).

Snap a chalk line on floor even with side jambs.

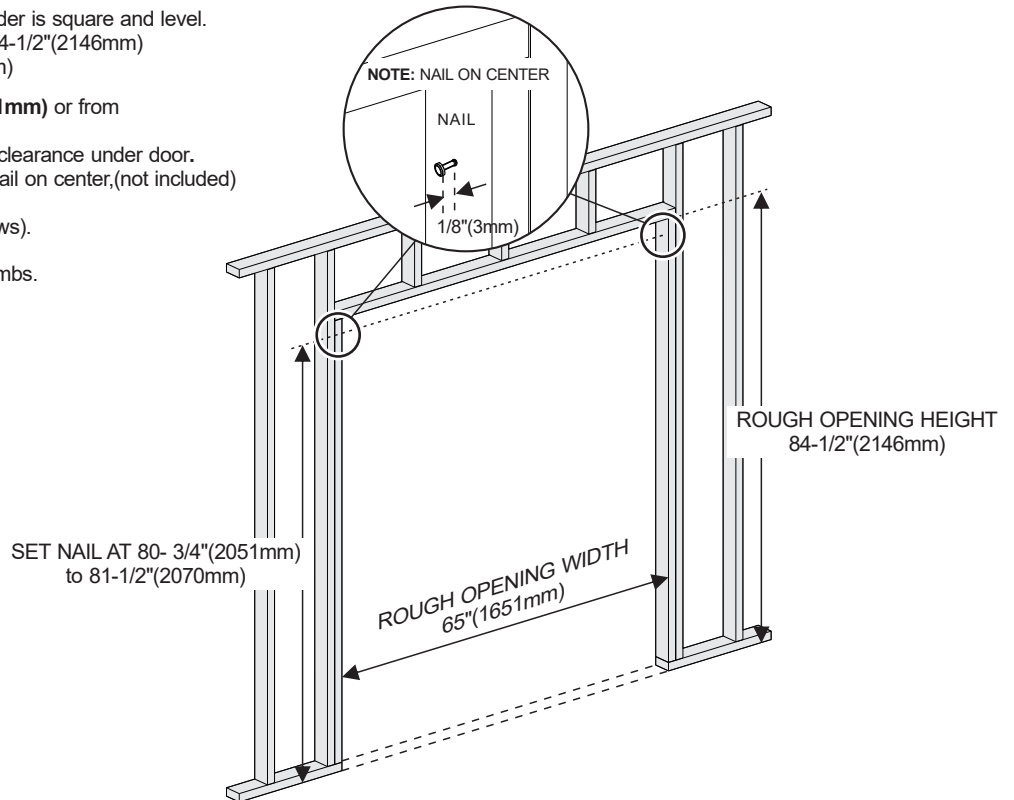

2 PREPARE HEADER AND TRACK

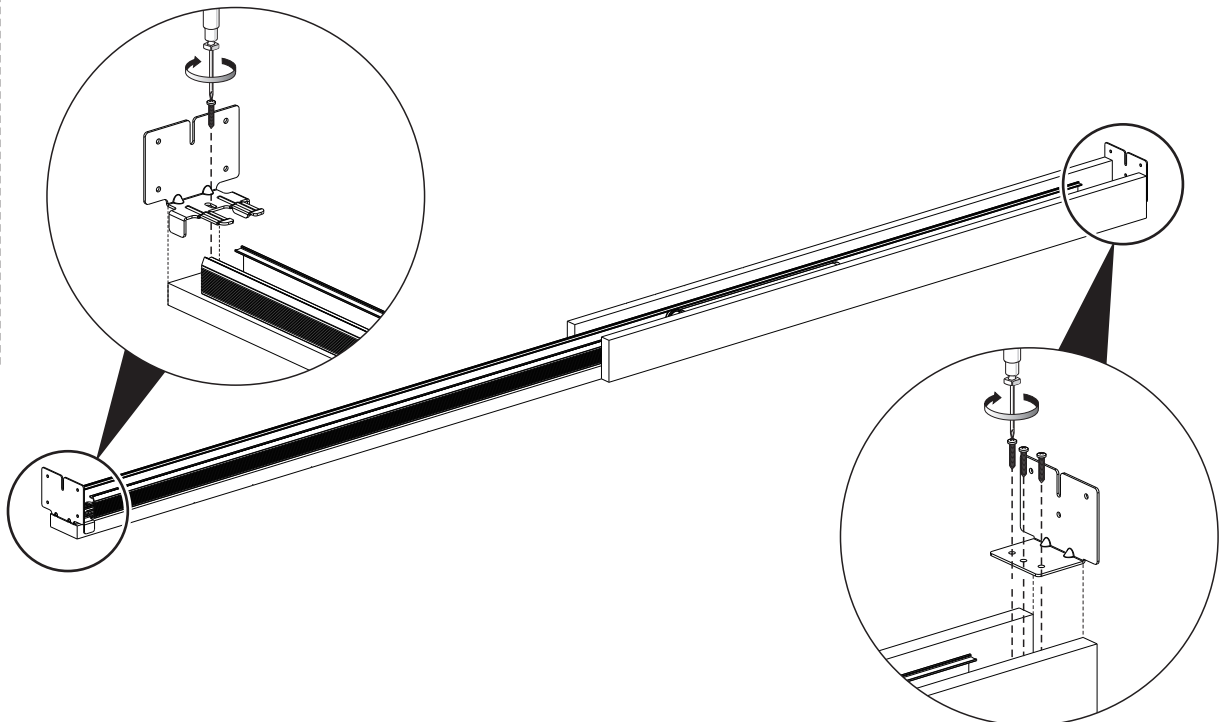
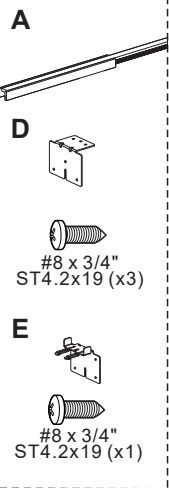

Installation

3

Slip slots in Frame Header End Plates over screws in rough studs. Level header. Set nails and drive nails through remaining holes in end plates.(not included)

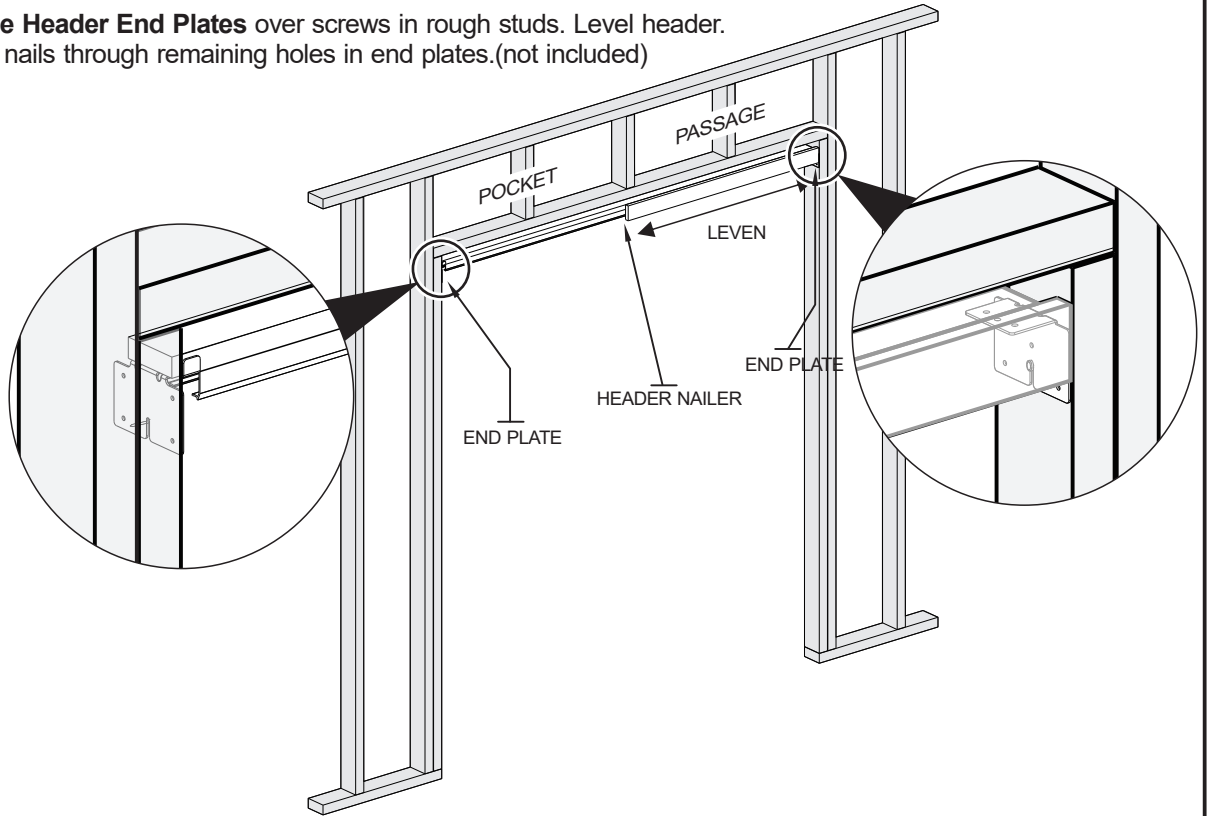

4 INSTALL THE SPLIT TUBES

G



#8 x 3/4"
ST4.2x19 (x8)

H



1. Slip fingers of Floor Plate into Split Steel Tube as shown.
2. Butt two Split Steel Tube against header nailer and screw into place with two #8x3/4"(4.2x19mm) Pan Head Screws.. Attach other Split Steel Tube midway in "Pocket" opening.
3. Plumb Split Steel Tube between chalk lines and nail to floor. (On masonry, use industrial adhesive or Tapcon fasteners.)

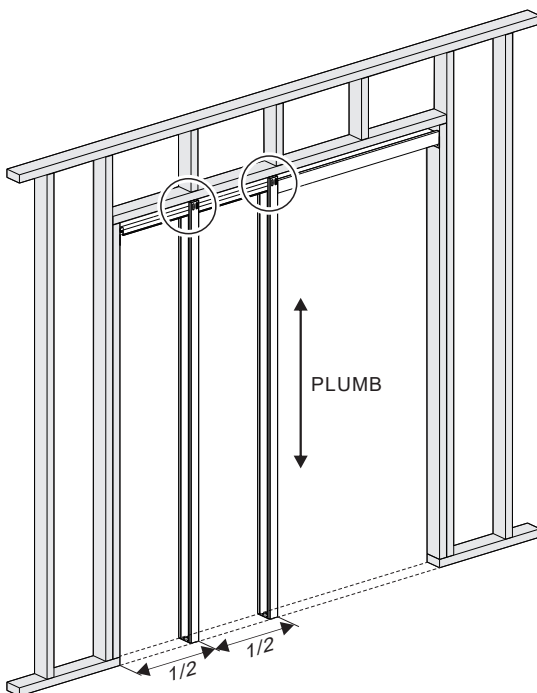

1

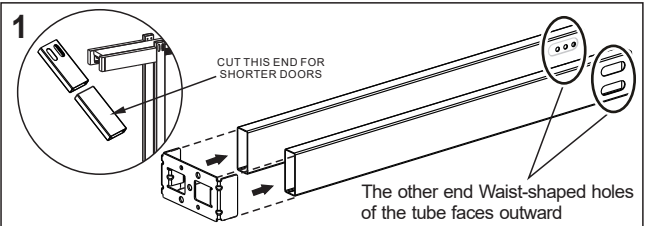

2

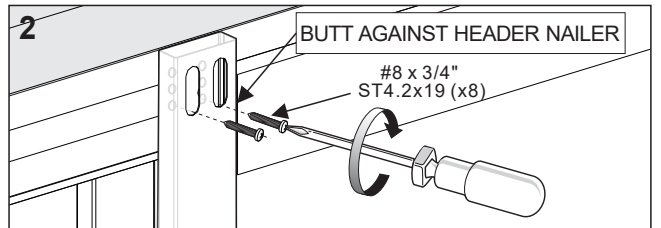

3

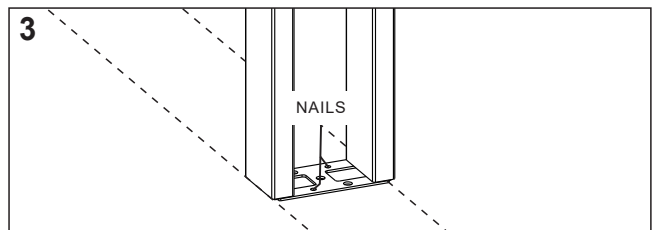

Installation

5 INSTALL SOFT CLOSE ACTUATOR

F Place the 1st soft close actuator/trigger into the track and have it 12" (305mm) far from the edge of the first split steel tube (close to door opening). Tighten it to the track.

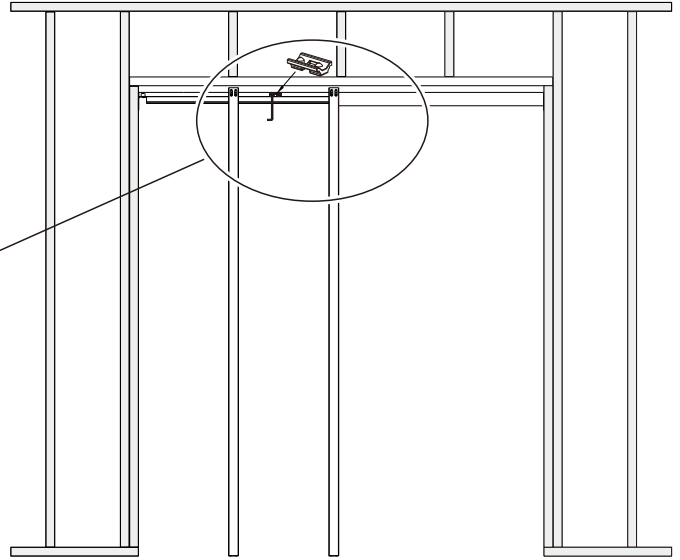
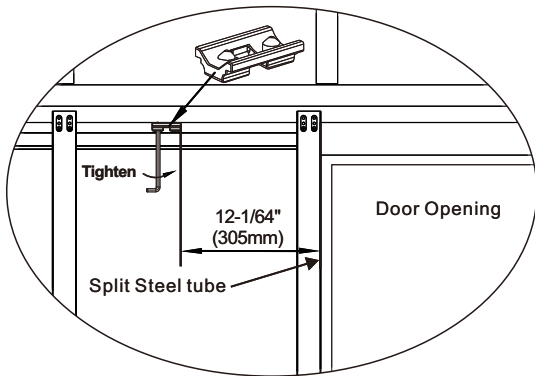
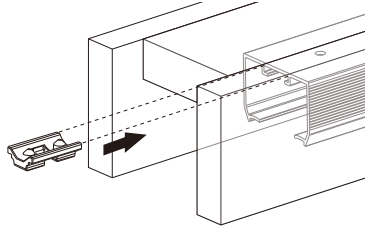

6 INSTALL HANGER WITHOUT SOFT CLOSE

C INSERT Ball Bearing Hanger Wheel assembly into Track.

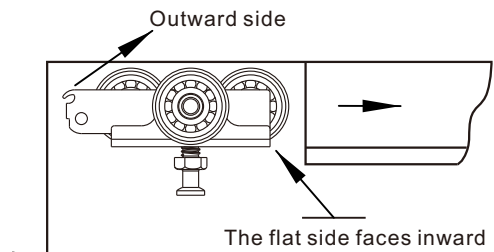
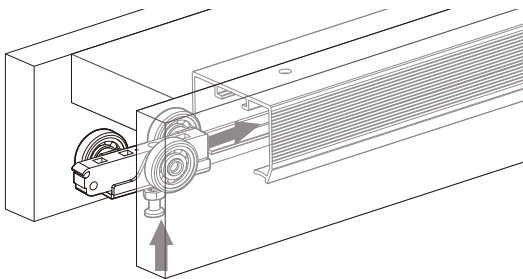

7 ENGAGE SOFT CLOSE DAMPENER

B Pushing Soft Close Dampener trigger toward "engaged" positions on both side. **Important** : Dampener must be **engaged**, or soft close will not work. If installed incorrectly, Soft Close Dampener may be **damaged** and door will have to be removed, and the installation of Soft Close will have to restart again.

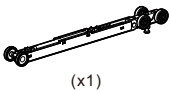

IMPORTANT  **MUST BE ENGAGED**

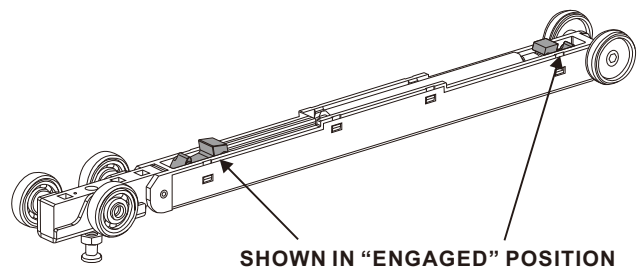
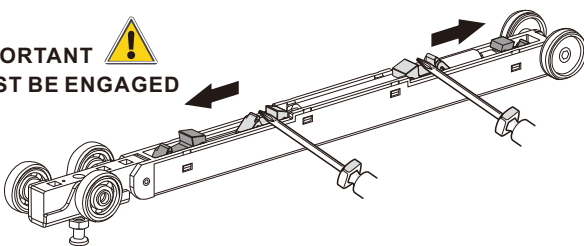

SHOWN IN "ENGAGED" POSITION

Installation

8 INSTALL SOFT CLOSE HANGER

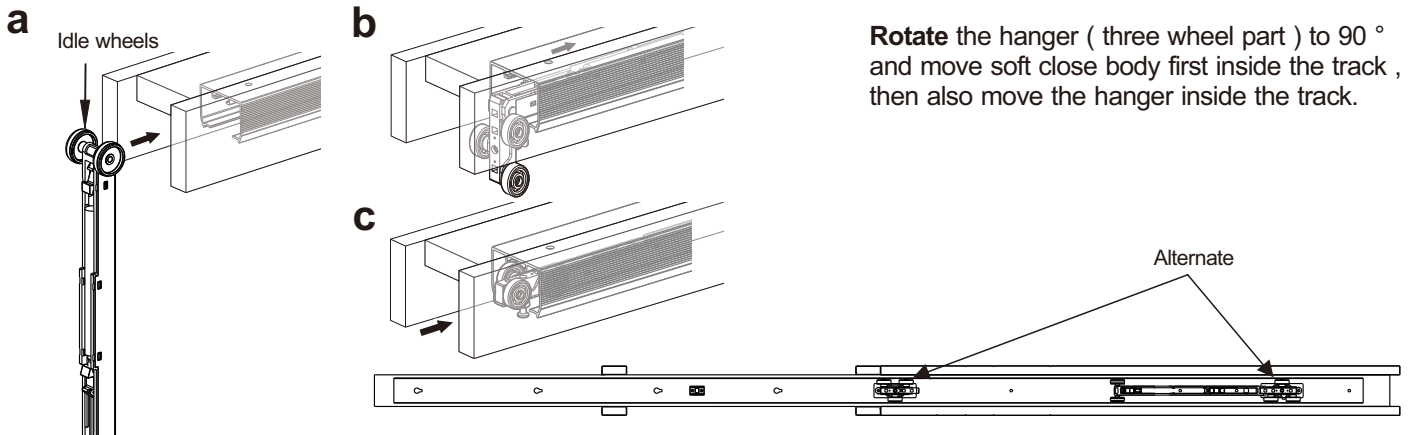

9 INSTALL SOFT CLOSE ACTUATOR

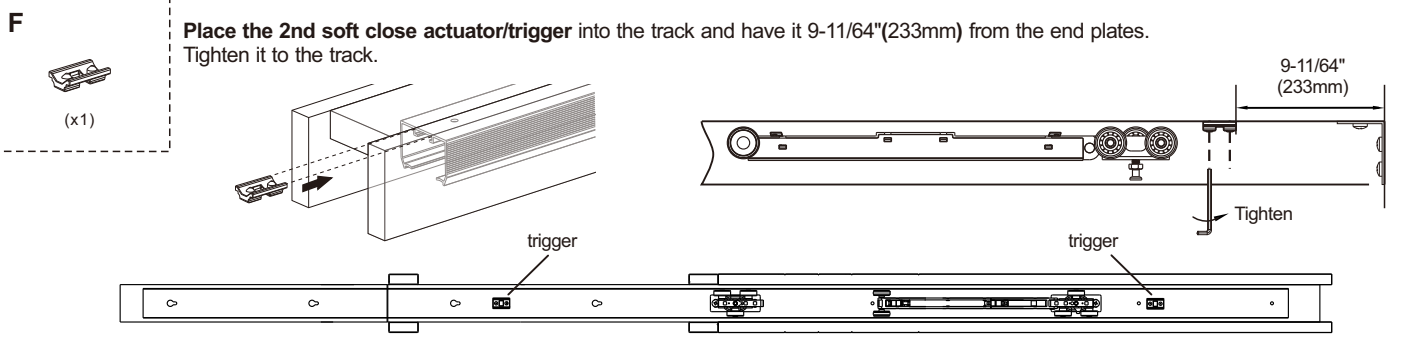

10 INSTALL SOFT CLOSE ACTUATOR

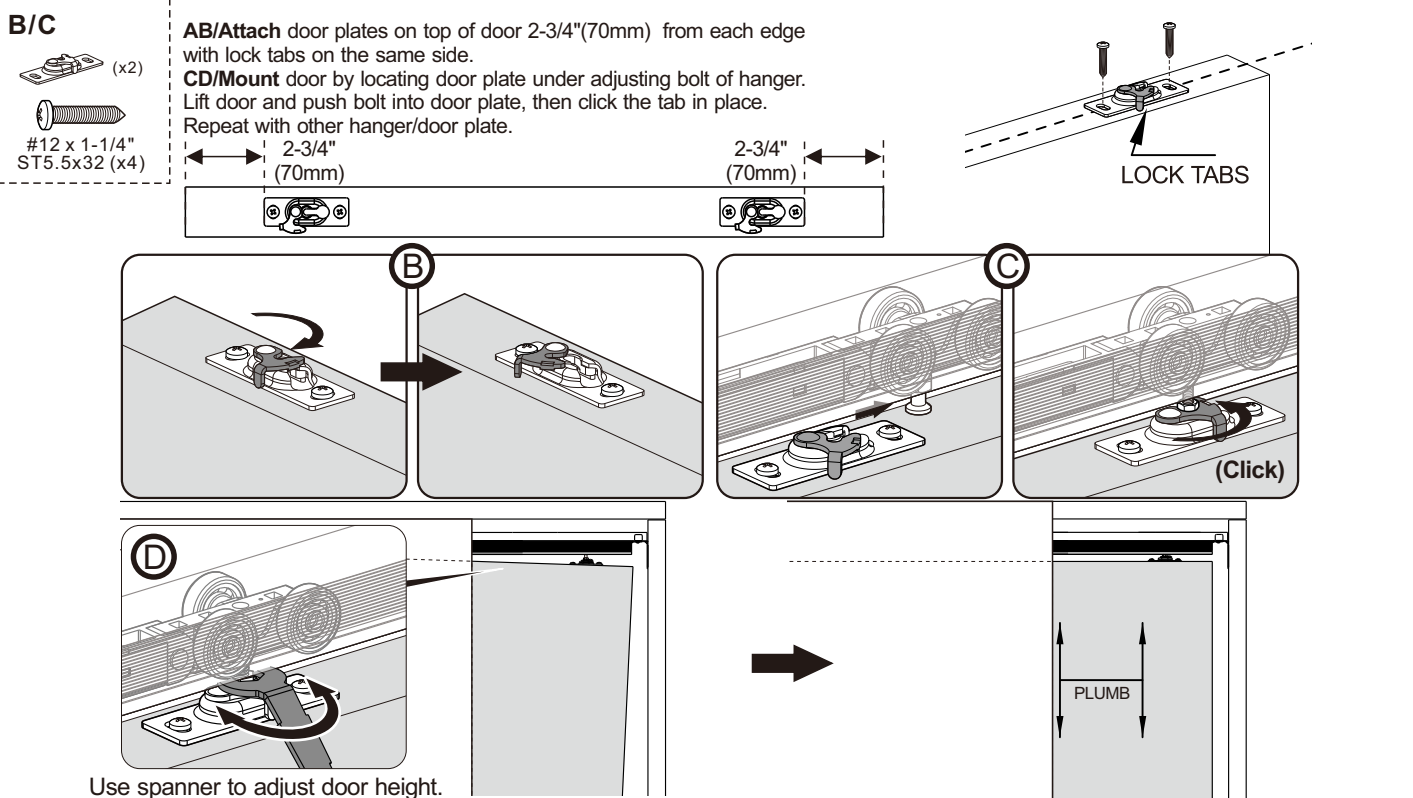

Installation

11 FINISH THE JAMBS AND TRIM

Fasten split header on lock lever side with screws for future door removal or adjustment. Install the finish trim or casing. Make sure to fasten the finish header trim to **ONLY** the wall and **NOT** the finish split header. This ensures the finish split header can be removed later without damage.

NOTE: Leave minimum 3/16" (5mm) clearance between jamb and door.

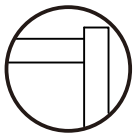

YES

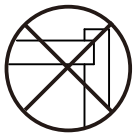

NO

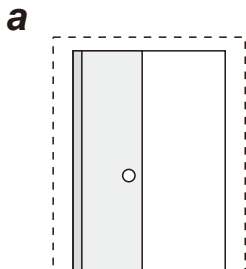

a
ATTACH FINISH SPLIT JAMB TO STEEL TUBE/
PLUMB DOOR WITH JAMB

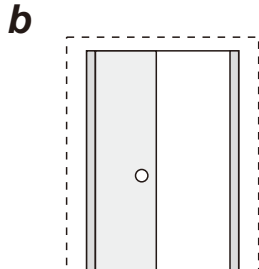

b
SHIM AND PLUMB FINISH JAMB WITH DOOR

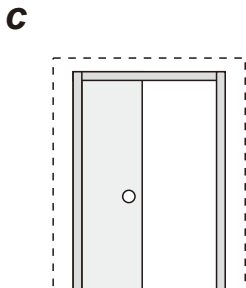

c
FINISH SPLIT HEADER

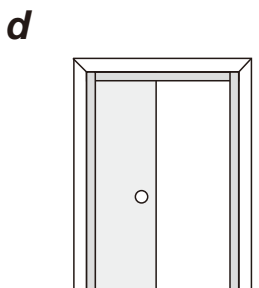

d
FINISH TRIM

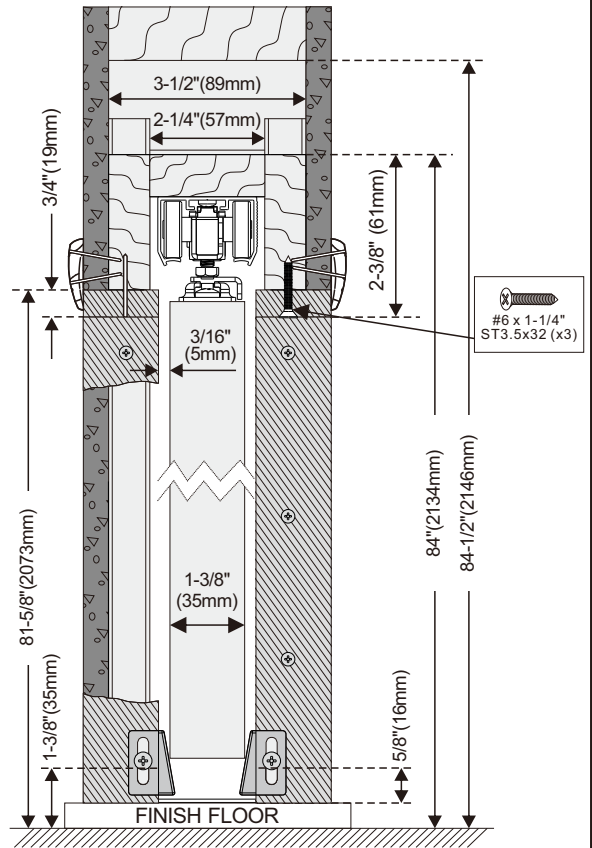

12 INSTALL DOOR GUIDE

I



(x2)



#8 x 33/64" ST4.2x13 (x2)

Fasten Guides on finished split jambs at door bottom so door is held in center of opening.

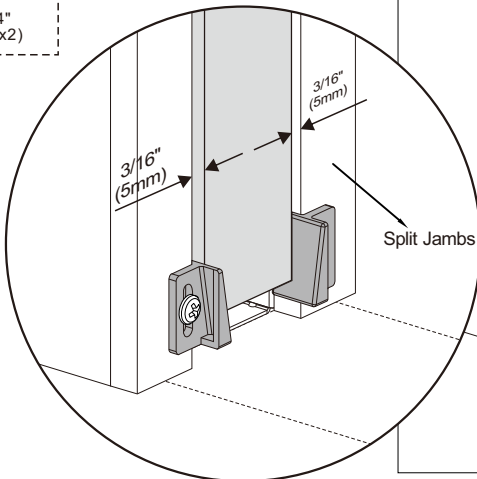

#8 x 33/64" (13mm)

