

# SOOHOW

## Assembly Manual

### 3-people seat

### CS003

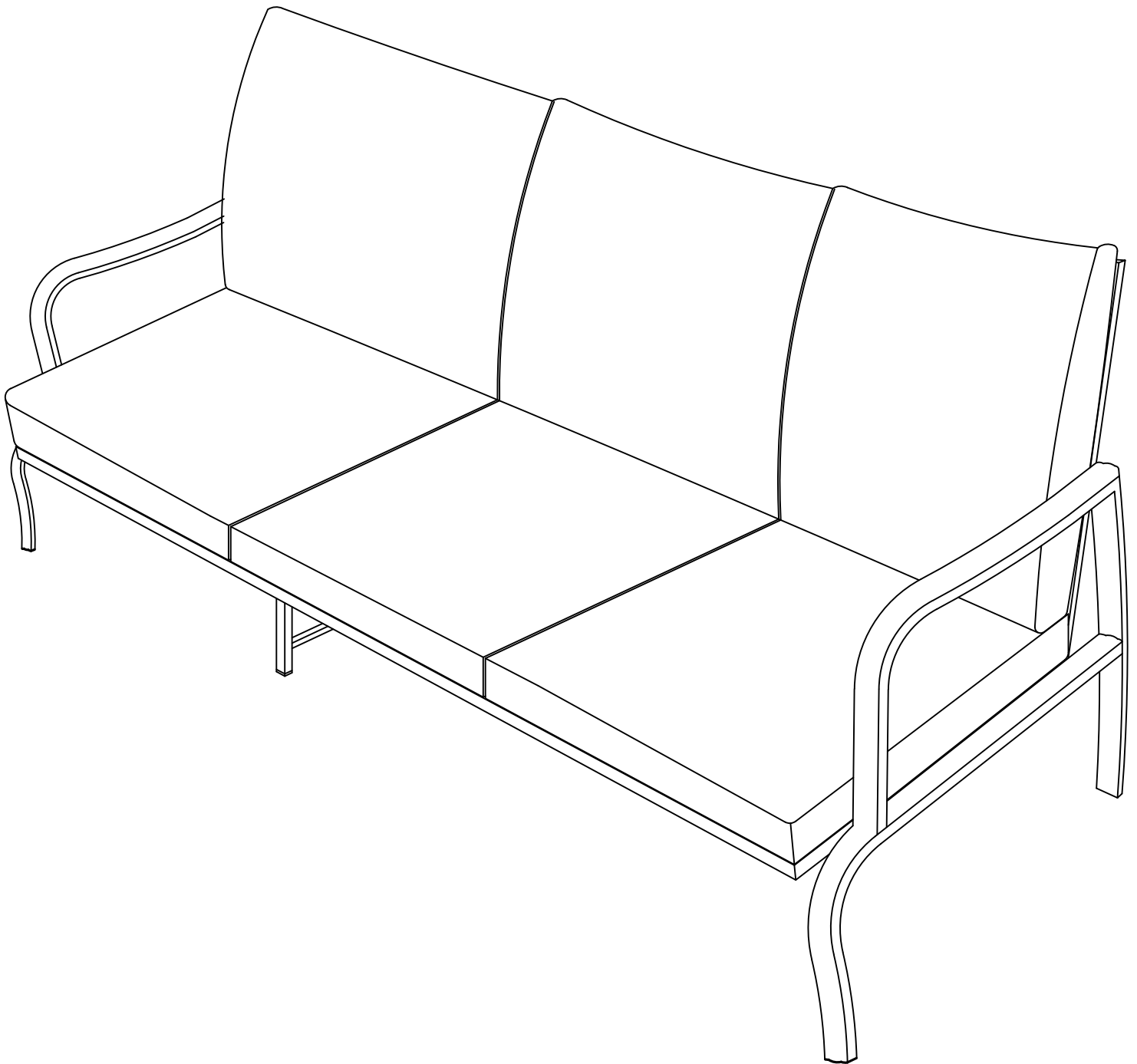



**Please read this manual carefully before any operation and keep it properly for future use.**

**If any problems on our product, please feel free to contact us at [ecservice@isunon.com](mailto:ecservice@isunon.com).**

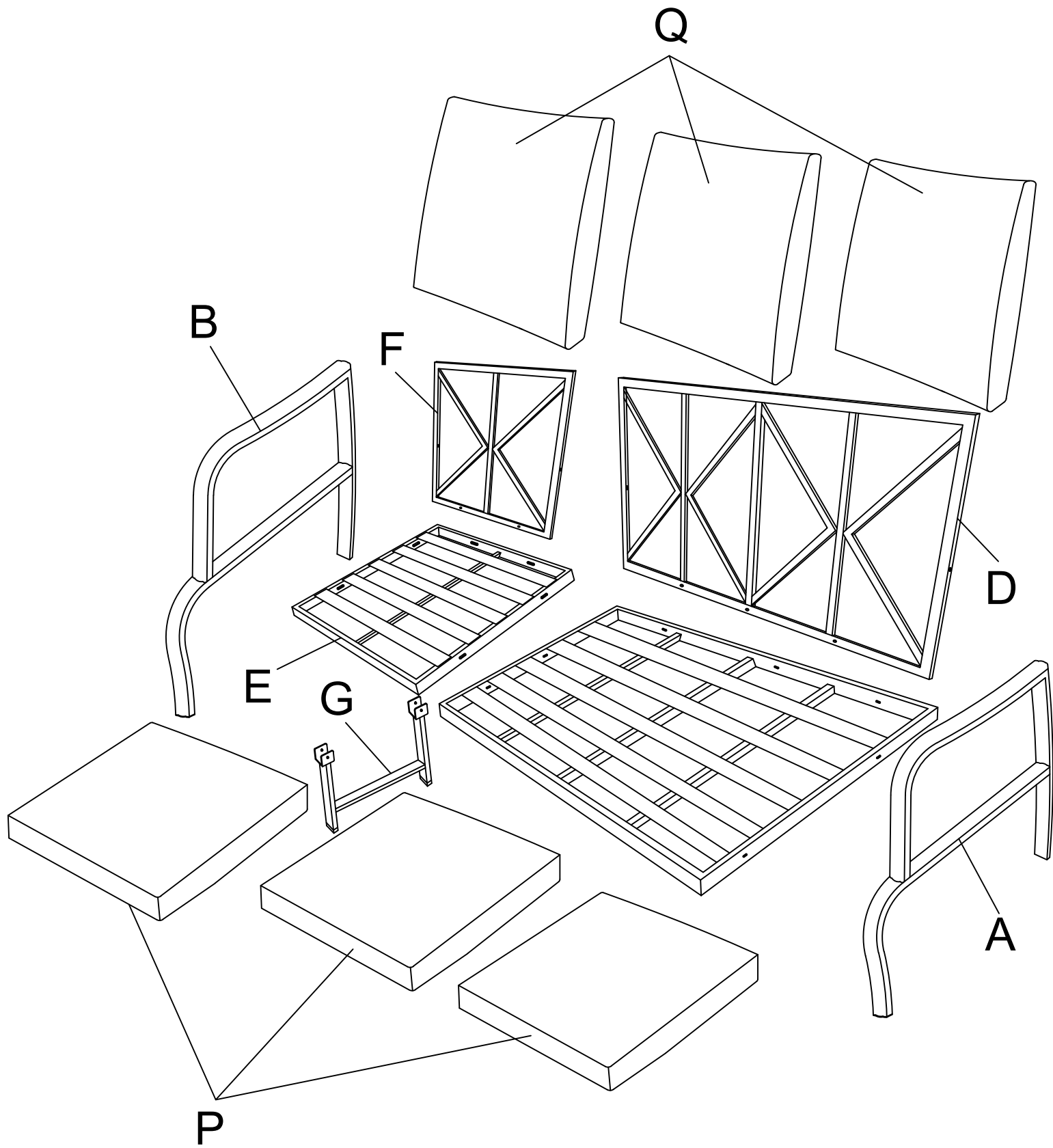
# Exploded View

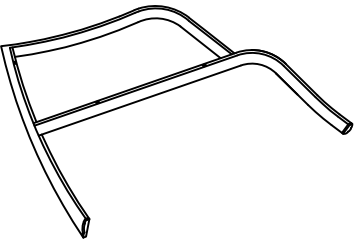
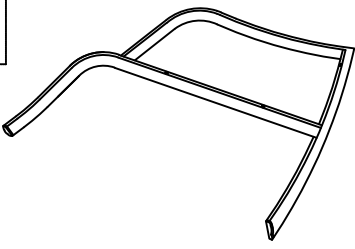
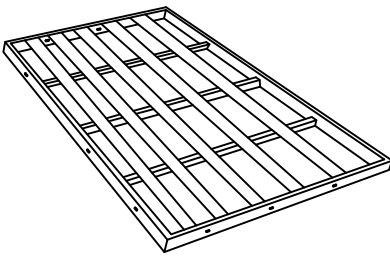
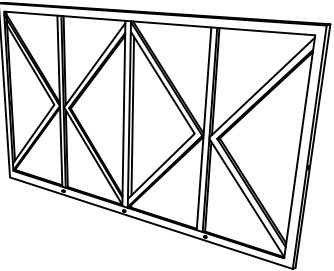
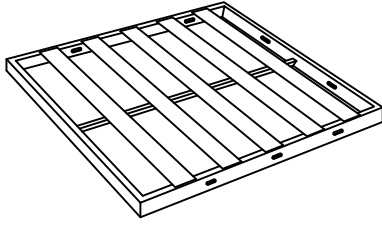
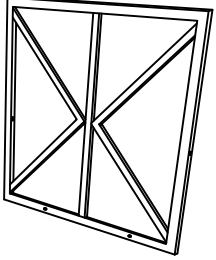
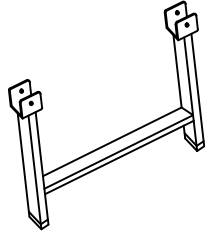
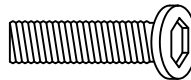
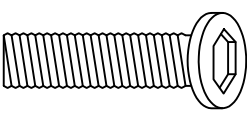
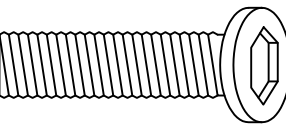
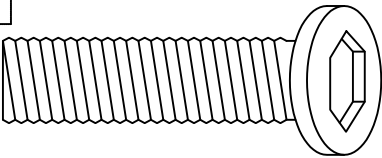

# Components List

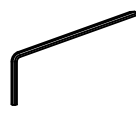
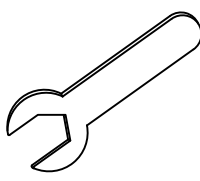
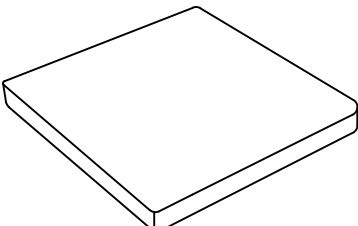
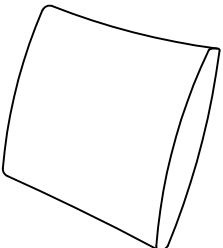
<b>A</b>  Left Armrest 1PC	<b>B</b>  Right Armrest 1PC	<b>C</b>  Double Seat 1PC
<b>D</b>  Double Back 1PC	<b>E</b>  Seat 1PC	<b>F</b>  Back 1PC
<b>G</b>  Leg 1PC	<b>H</b>  Bolt M6X30 10PCS	<b>I</b>  Bolt M6X40 3PCS
<b>J</b>  Bolt M6X45 3PCS	<b>K</b>  Bolt M6X65 3PCS	<b>L</b>  Nut M6 5PCS
<b>M</b>  Washer M6 24PCS	<b>N</b>  Allen wrench M6 1PC	<b>O</b>  wrench M6 1PC
<b>P</b>  Seat Cushion 3PCS	<b>Q</b>  Back Cushion 3PCS	

# ASSEMBLY INSTRUCTION

**Step 1** Attach left armrest(A) to the seat board(C) using washers(M), bolts(H) and Allen wrench(N). *Hand-tighten all screws to about 80% first. After all screws are in place, tighten them fully in sequence*

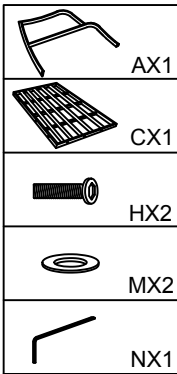
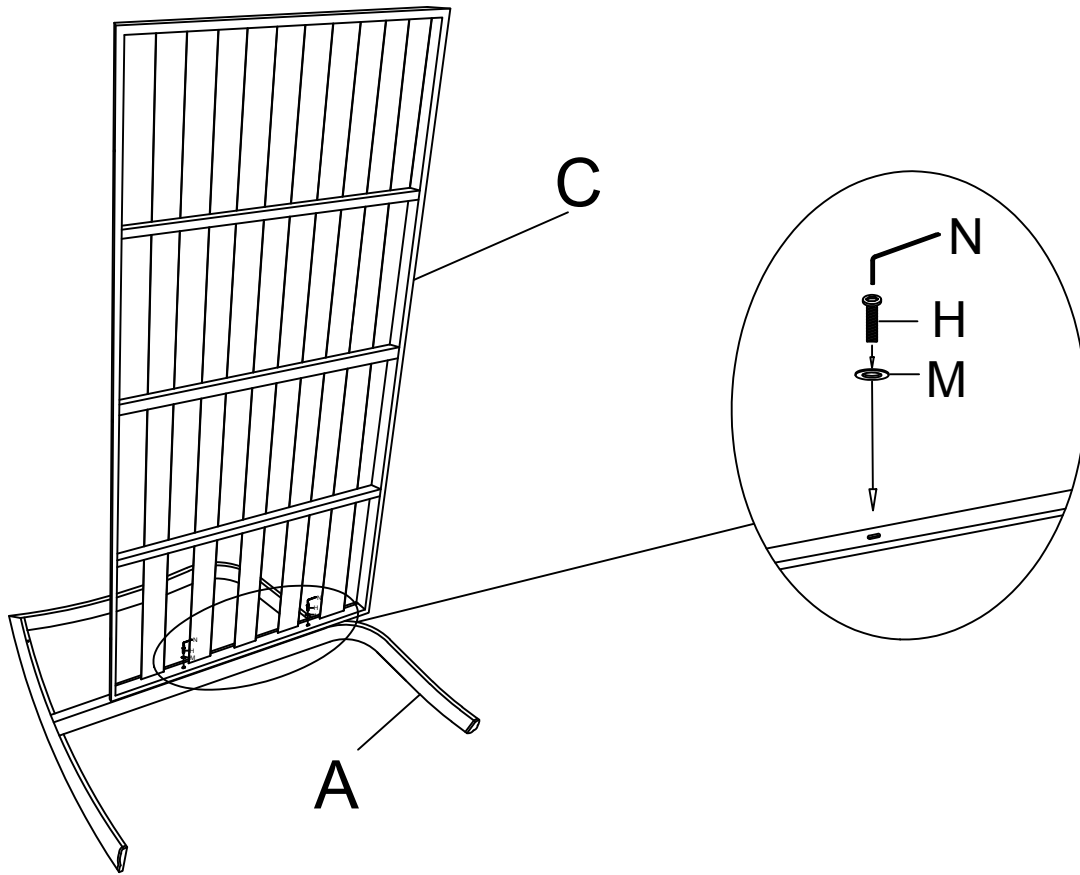

**Step 2** Attach back frame(D) to the seat frame using washers(M), bolts(H&I), and Allen wrench(N). *Hand-tighten all screws to about 80% first. After all screws are in place, tighten them fully in sequence*

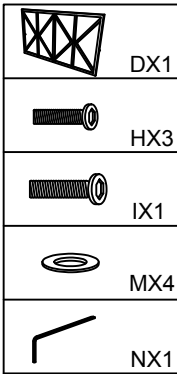
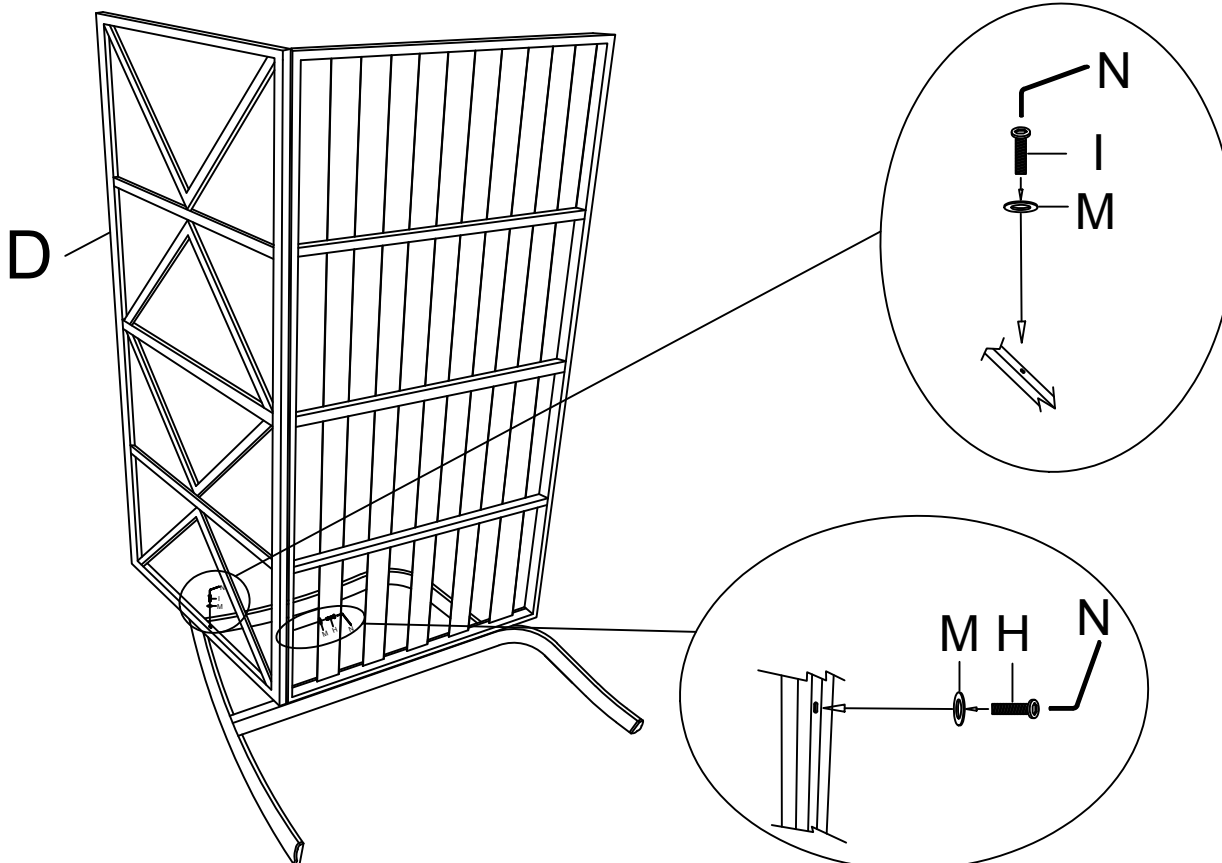

# ASSEMBLY INSTRUCTION

## Step 3

Attach back frame(F) to the seat frame(E) using washers(M), bolts(H), and Allen wrench(N). Attach single seat to the love seat frame using nuts(L), washers(M), bolts(K), and Allen wrench(N&O). Attach middle leg(G) to the seat frame using nuts(L), washers(M), bolts(J), and Allen wrench(N&O). **Hand-tighten all screws to about 80% first. After all screws are in place, tighten them fully in sequence**

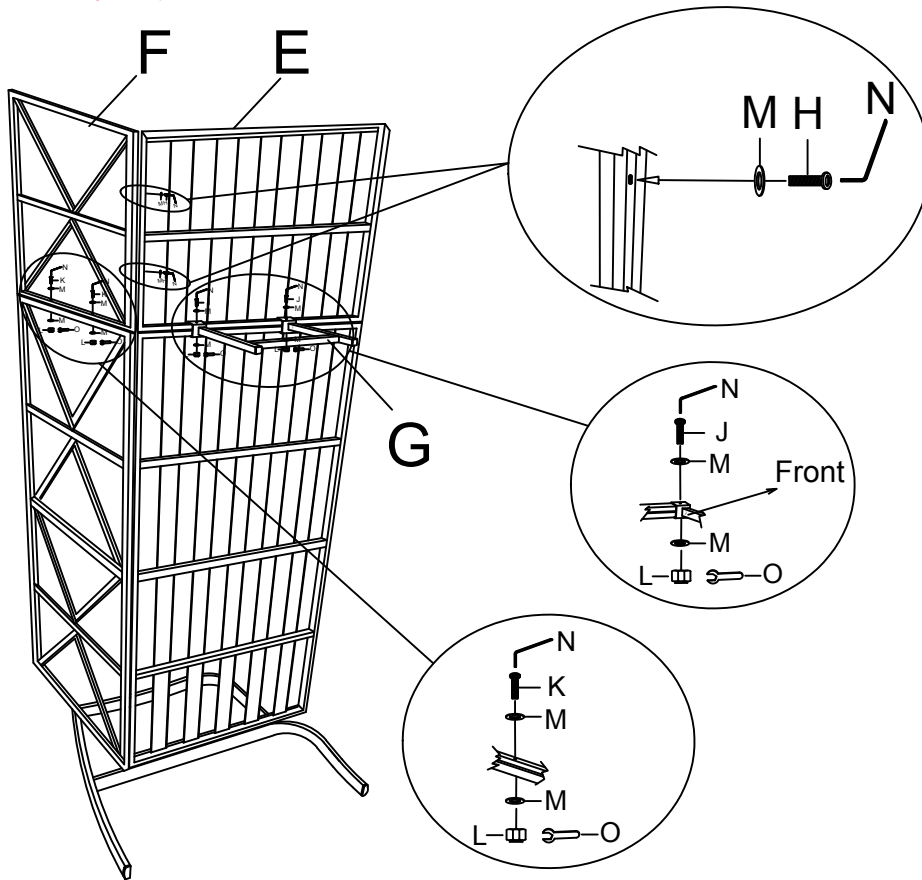

	EX1
	FX1
	GX1
	HX2
	JX2
	KX2
	MX10
	LX4
	NX1
	OX1

## Step 4

Attach right armrest(A) to the seat board(C) using washers(M), bolts(H&I) and Allen wrench(N). **tighten all screws to about 80% first. After all screws are in place, tighten them fully in sequence**

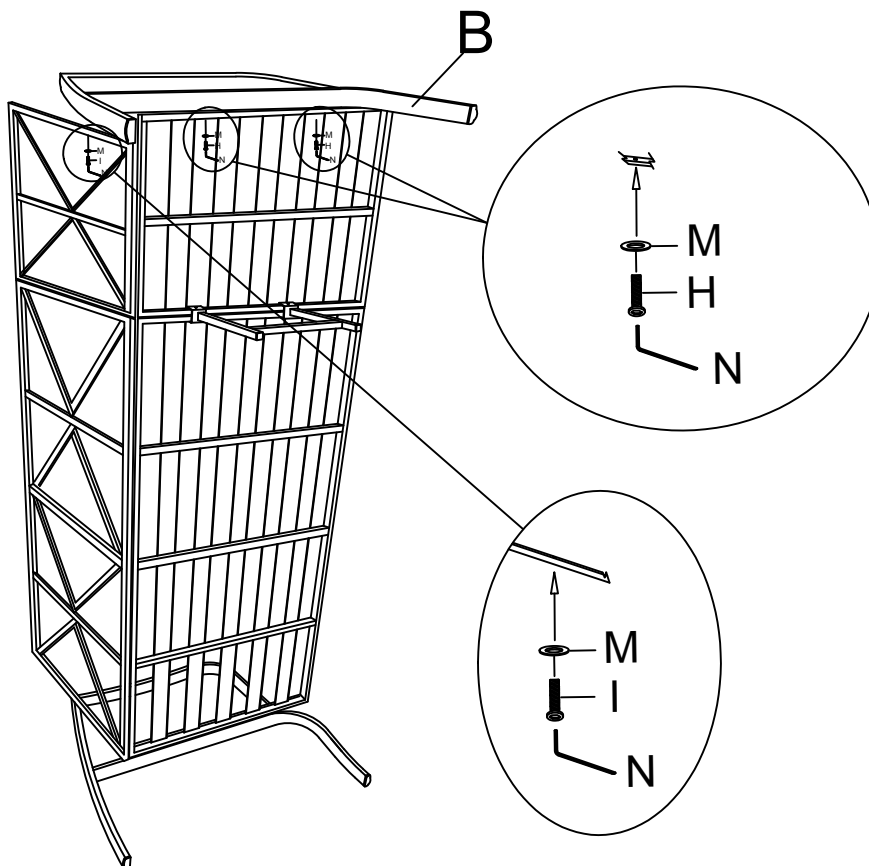

	BX1
	HX2
	IX1
	MX3
	NX1

# ASSEMBLY INSTRUCTION

## Step 5

Tighten all bolts 100%, and flip the seat over. Put the seat cushion(P) and back cushion(Q) on the seat frame. The assembly is done.

