

Assembly Instruction

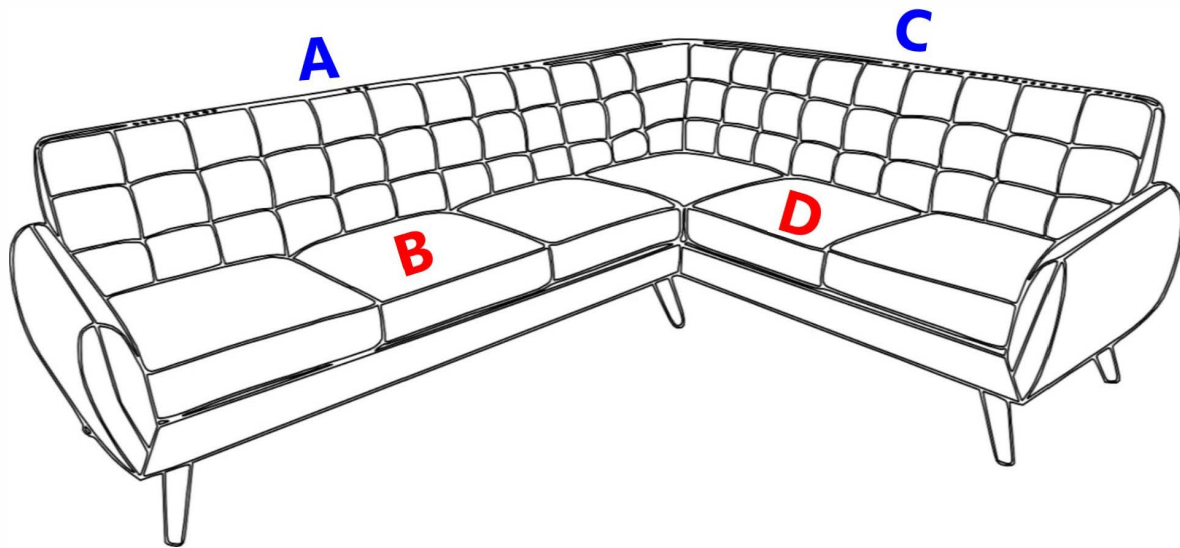

BOX 1 - RAF LOVE + WEDGE

PART LIST



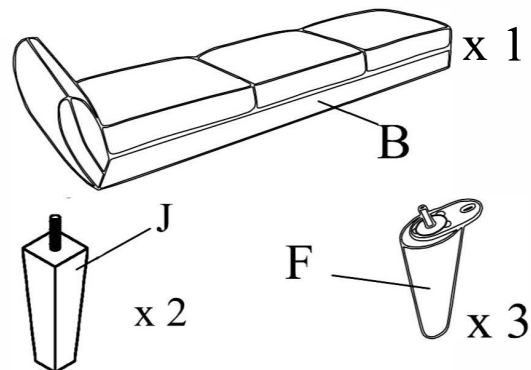
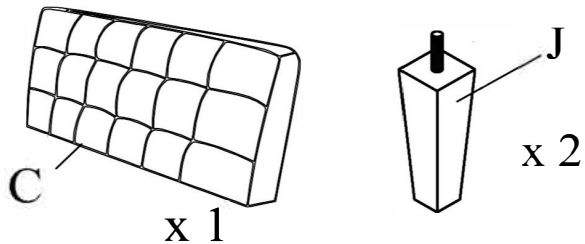
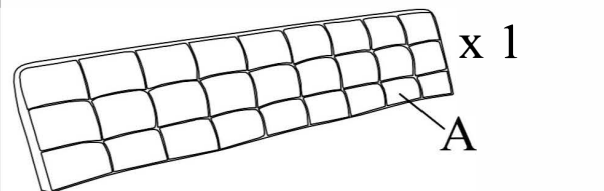
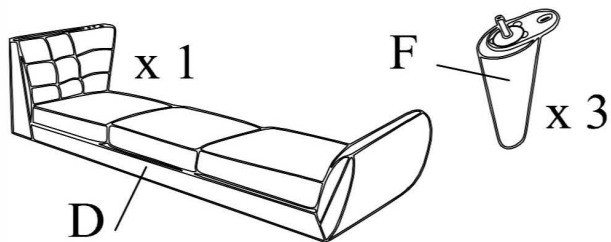

BOX 2 - LAF 3-SEAT SOFA

BOX 1:F6961-1, F6962-1, F6963-1

BOX 2:F6961-2, F6962-2, F6963-2



HARDWARE LIST

①	 x 6	②	 x 6	③	 x 6
	Bolt 5/16" * 30mm		Lock Washer Ø5/16"		Flat Washer Ø5/16"
④	 x 1				
	Allen Wrench M4				



Please follow the drawings below to assemble this item.

Step 1. Take out the legs from the inner box, and then rotate / tighten into the position at bottom of the left - facing sofa and the matching right - facing loveseat wedge as shown in below drawings.

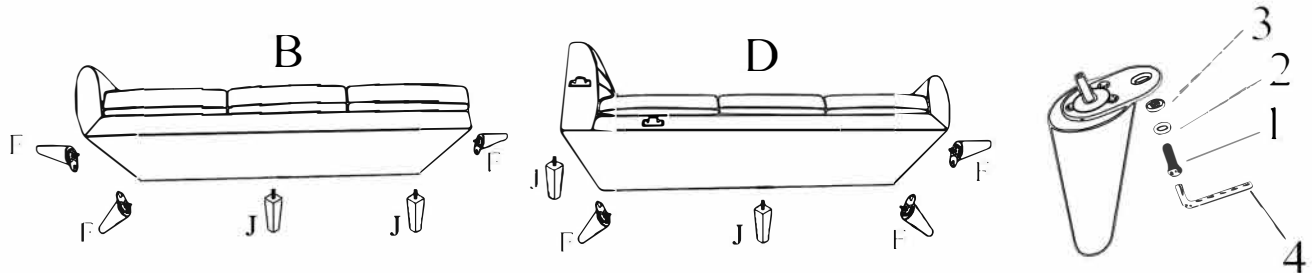

Step 2. Align female brackets with the male one at the back & seat. And then insert / push the whole backrest to the seat. Make sure the brackets are secured in position before using.

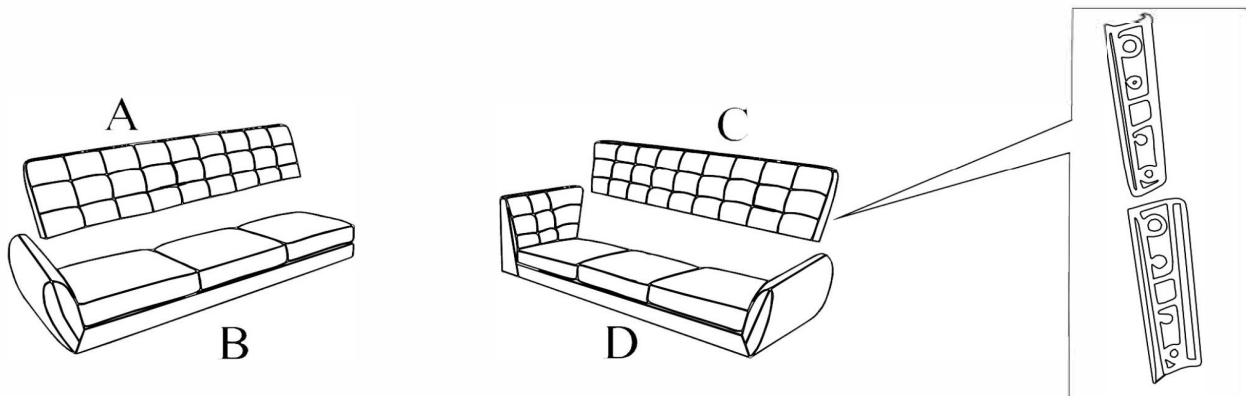

Step 3. Left - facing sofa and right - facing loveseat wedge can be attached together by the brackets as shown in below drawings.

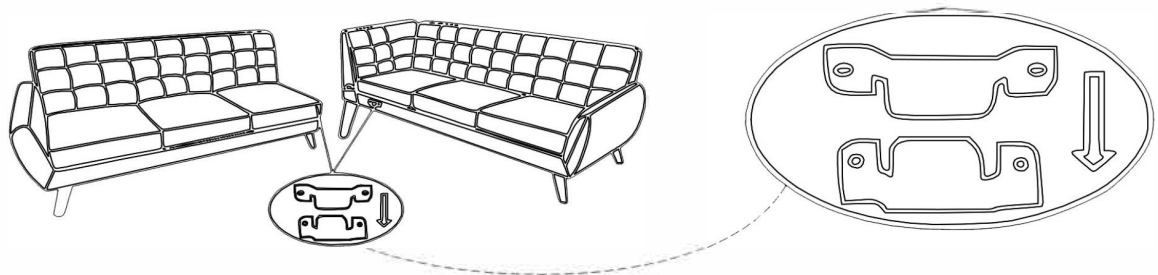

Step 4. Completed

