

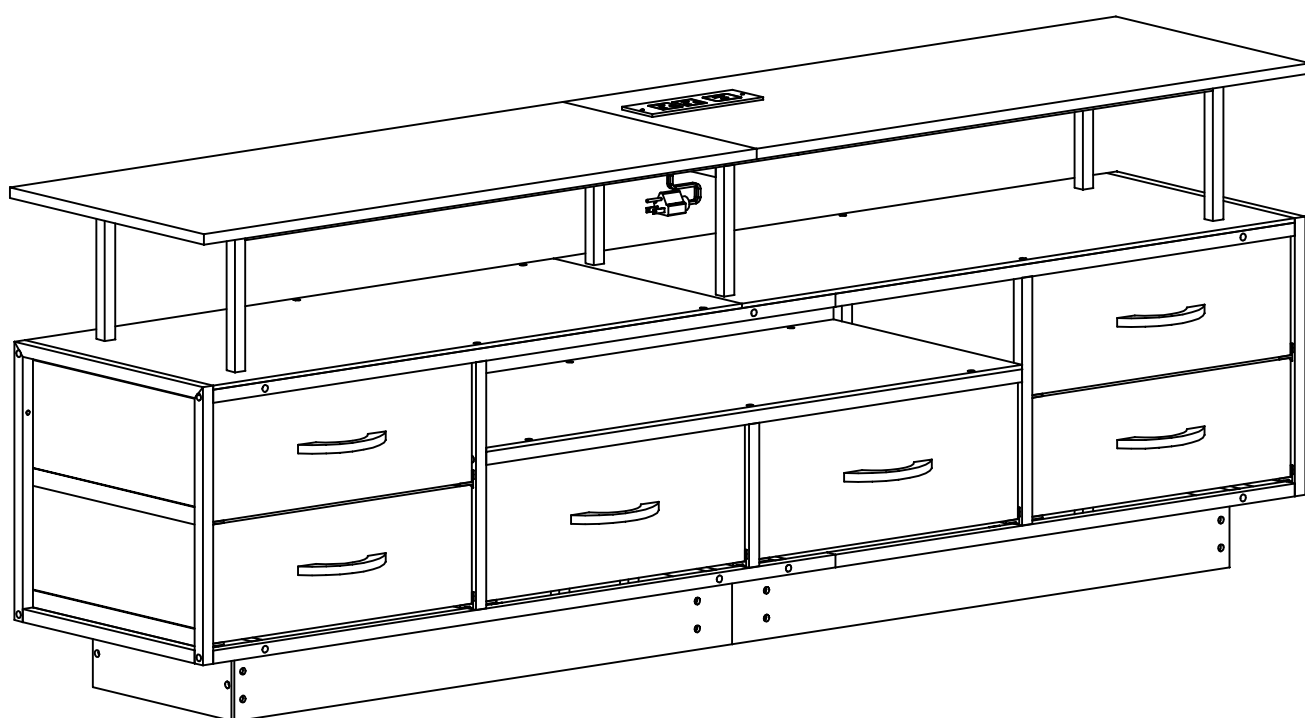

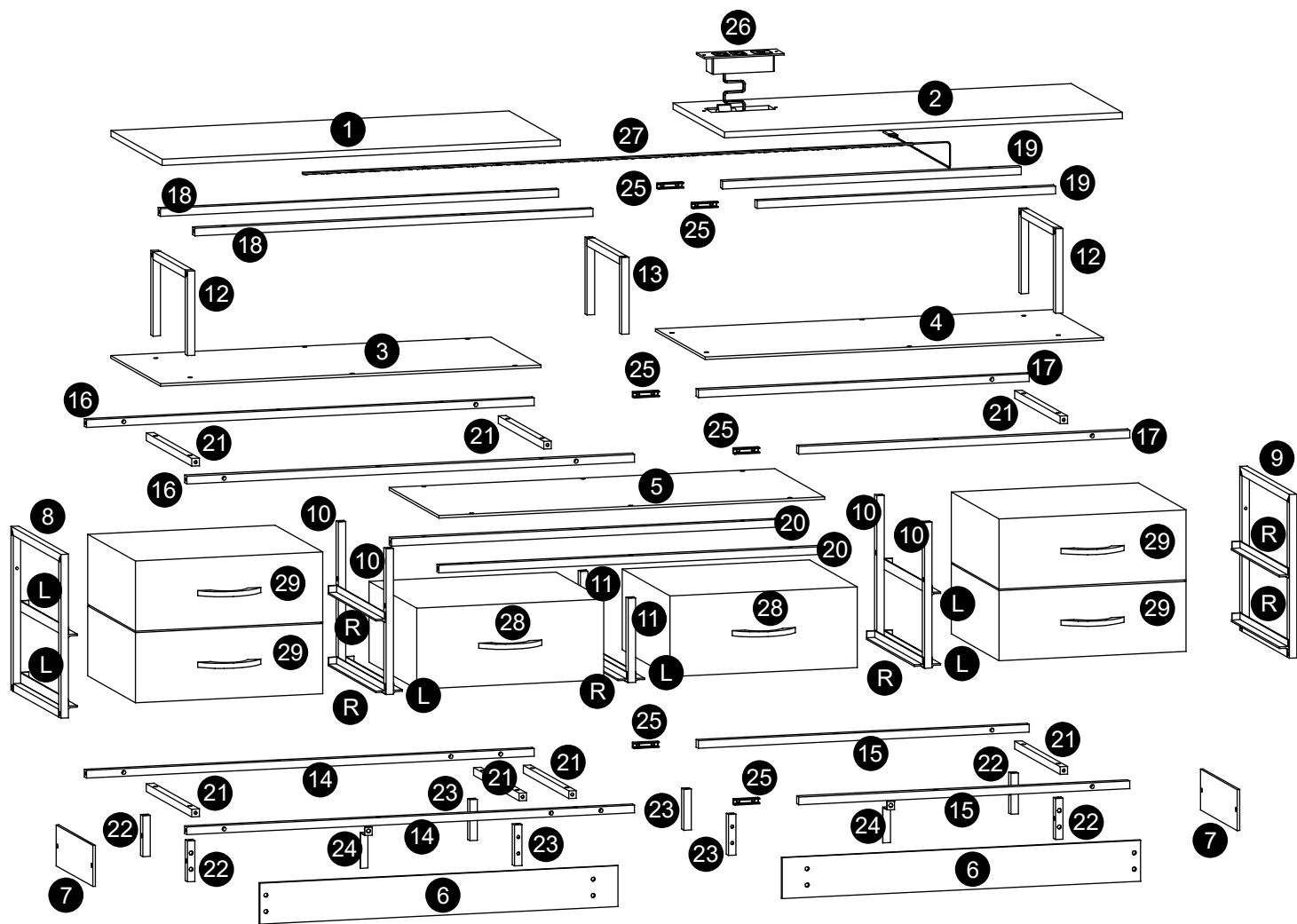



Installation & Assembly



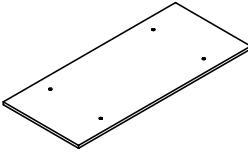
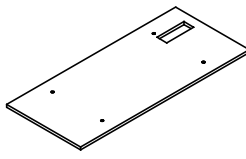
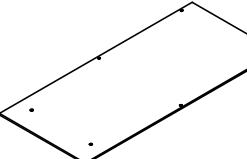
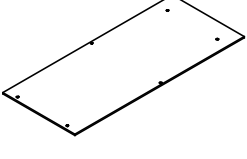
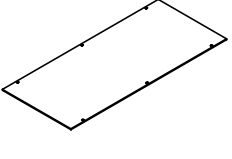
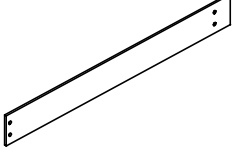
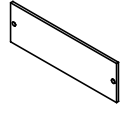
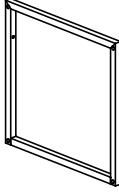
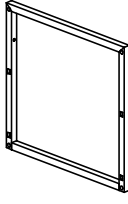

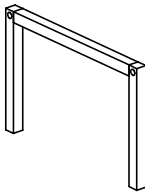
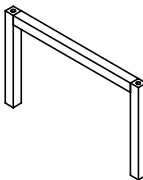
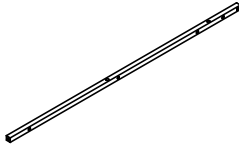
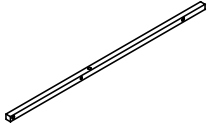
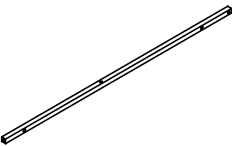
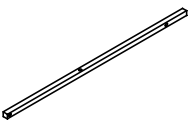
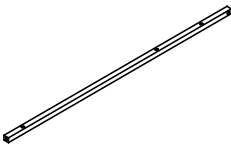
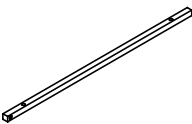
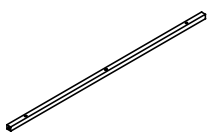

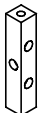
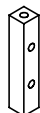
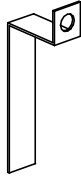

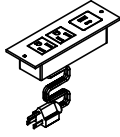
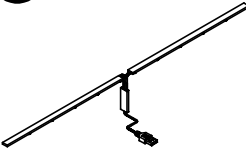
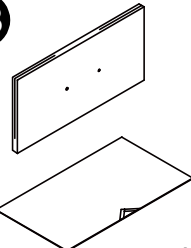
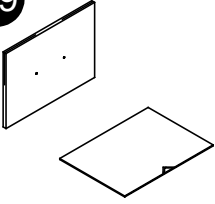



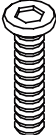

Assembling Instruction

Attention: Do not tighten the screws until all of them are in right positions

1  X1	2  X1	3  X1	4  X1	5  X1
6  X2	7  X2	8  X1	9  X1	10  X4
11  X2	12  X2	13  X1	14  X2	15  X2
16  X2	17  X2	18  X2	19  X2	20  X2
21  X7	22  X4	23  X4	24  X2	25  X6
26  X1	27  X1	28  X2	29  X4	

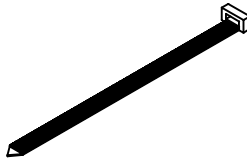
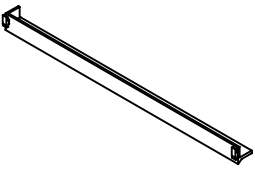
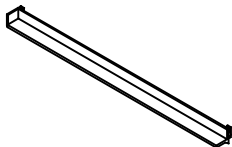
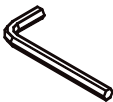
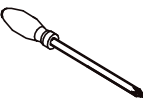
<p>A</p>  <p>M6X10 X32</p>	<p>B</p>  <p>M6X22 X54</p>	<p>C</p>  <p>M6X28 X12</p>	<p>D</p>  <p>M4X10 X12</p>	<p>E</p>  <p>M4X12 X2</p>
<p>F</p>  <p>X6</p>	<p>G</p> <div style="border: 1px solid black; padding: 5px; display: inline-block;">  <p>M6X30</p>  <p>M4X50</p> </div> <p>X2</p>	<p>H</p> <div style="border: 1px solid black; padding: 5px; display: inline-block;">   <p>M3X8</p> </div> <p>X4</p>	<p>J</p>  <p>X4</p>	<p>L</p>  <p>X6</p>
<p>R</p>  <p>X6</p>				

Step 1

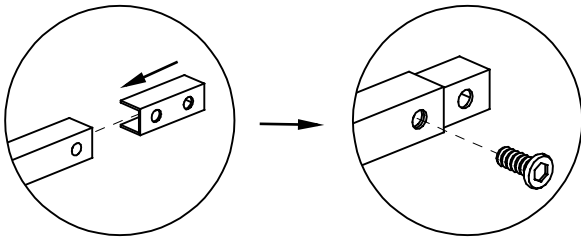
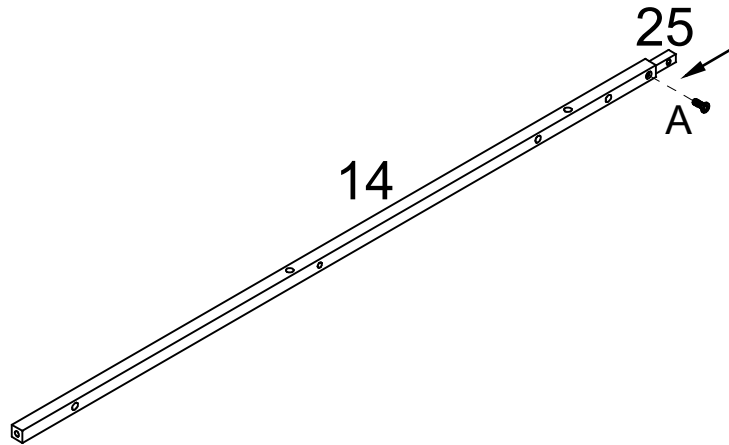

X2

A	M6X10	X2
---	-------	----

Step 2

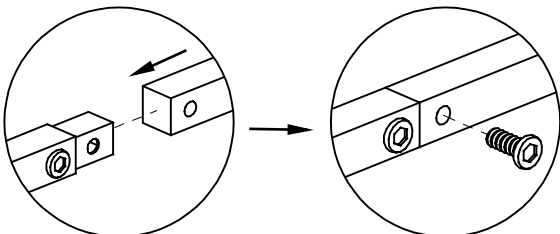
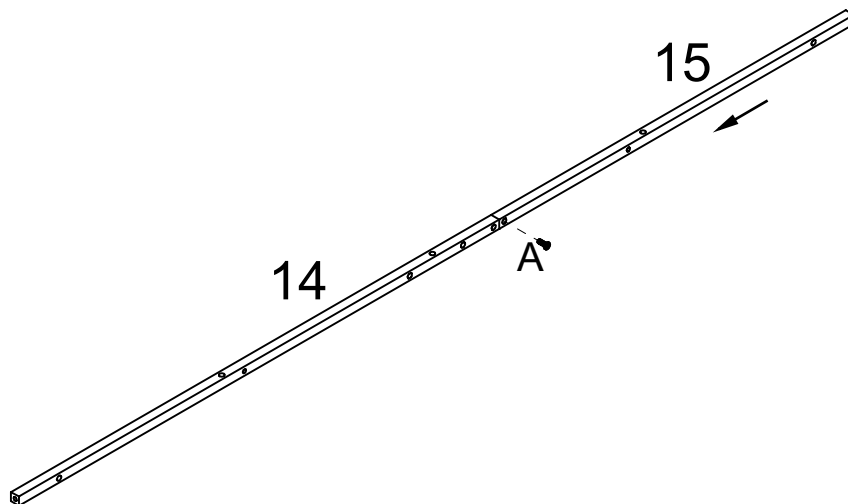

X2

A	M6X10	X2
---	-------	----

Step 3

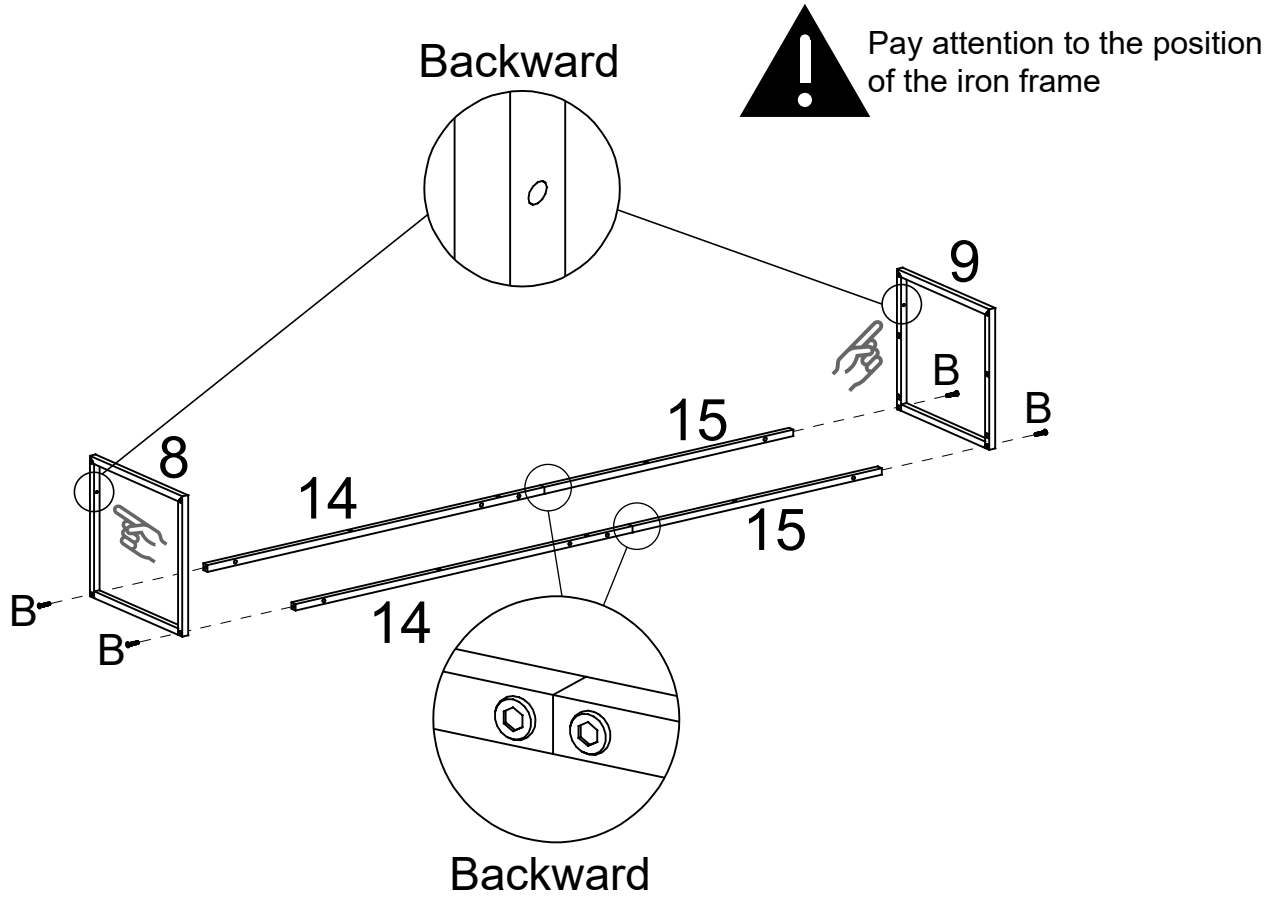

B	M6X22	X4
---	-------	----

Step 4

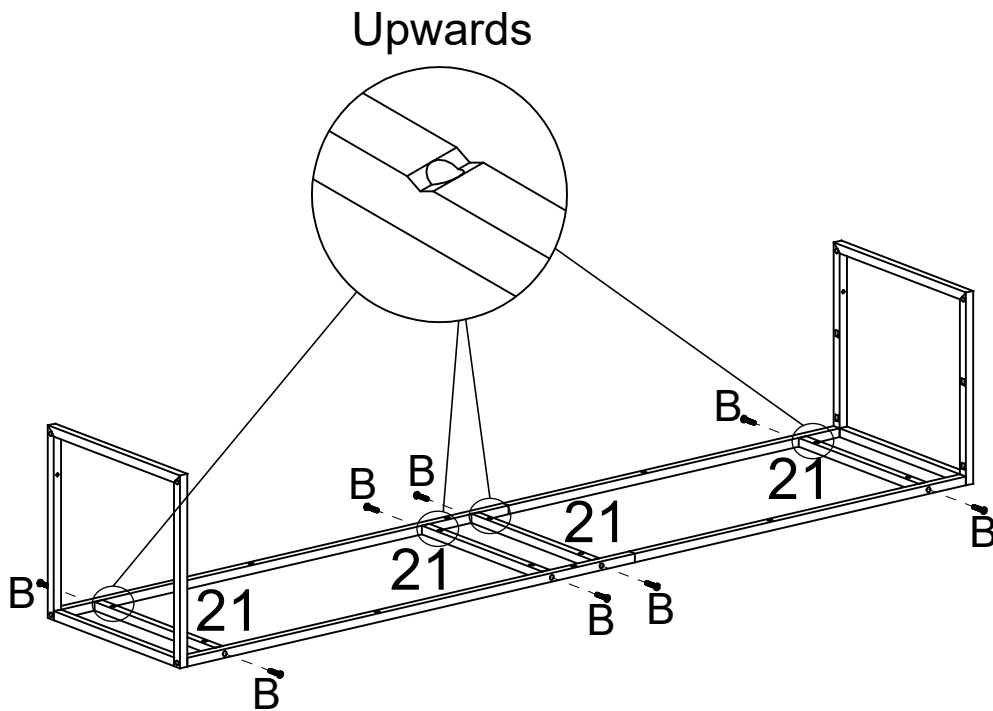

B	M6X22	X8
---	-------	----

Step 5

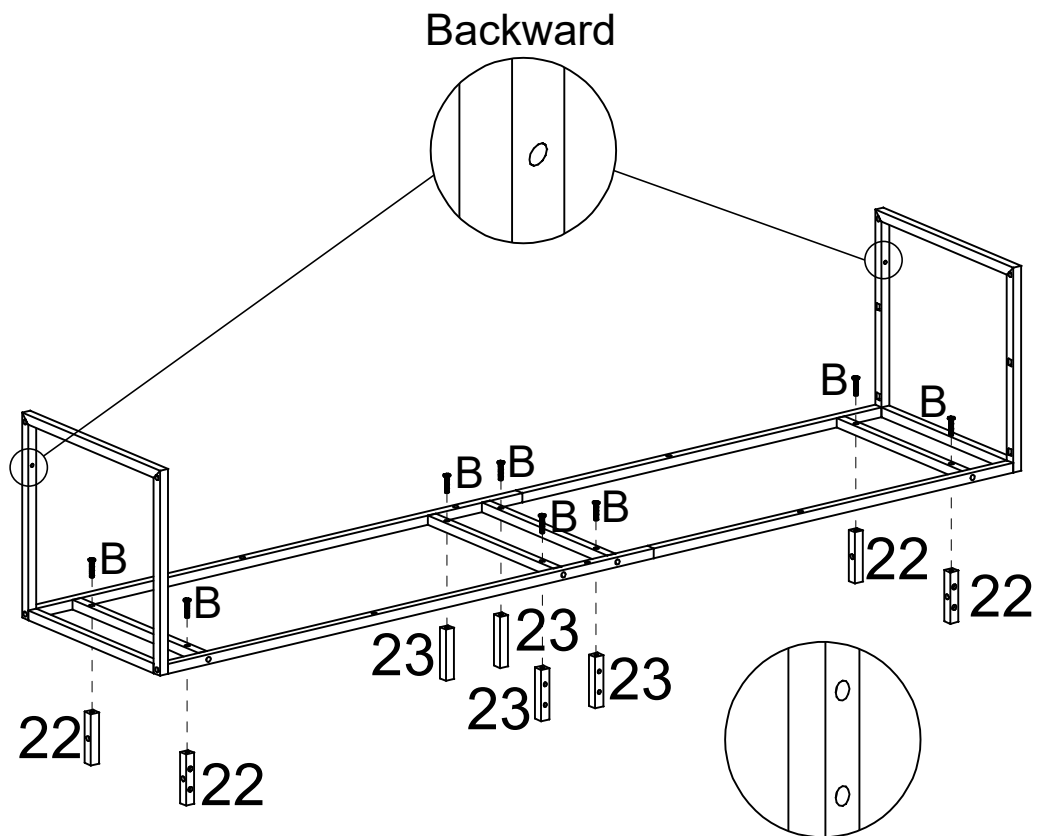

The two holes face outwards

B	M6X22	X8
---	-------	----

Step 6

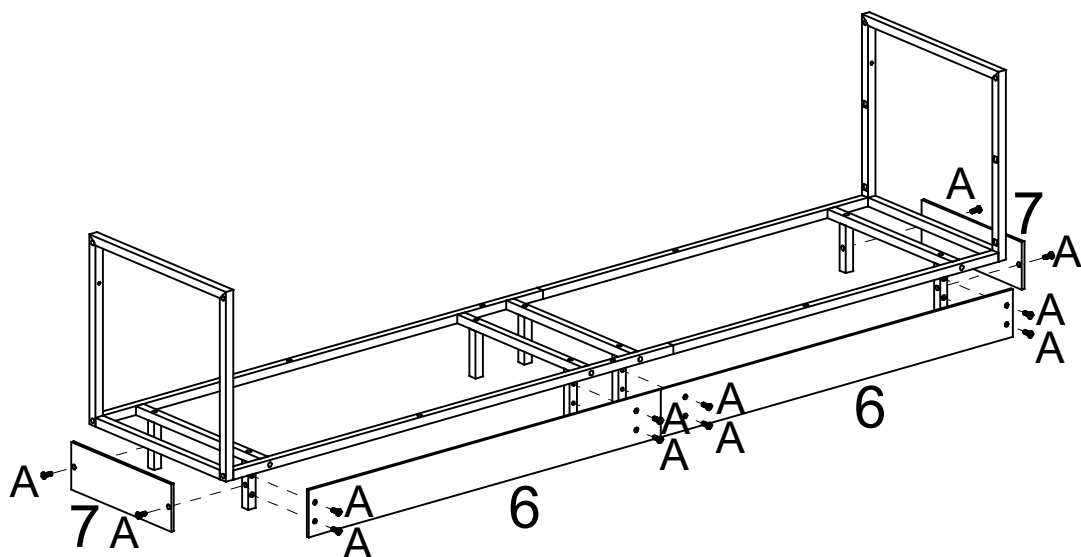

Do not tighten the screws, and then tighten the screws when the board is in the correct position

A	M6X10	X12
---	-------	-----

Step 7

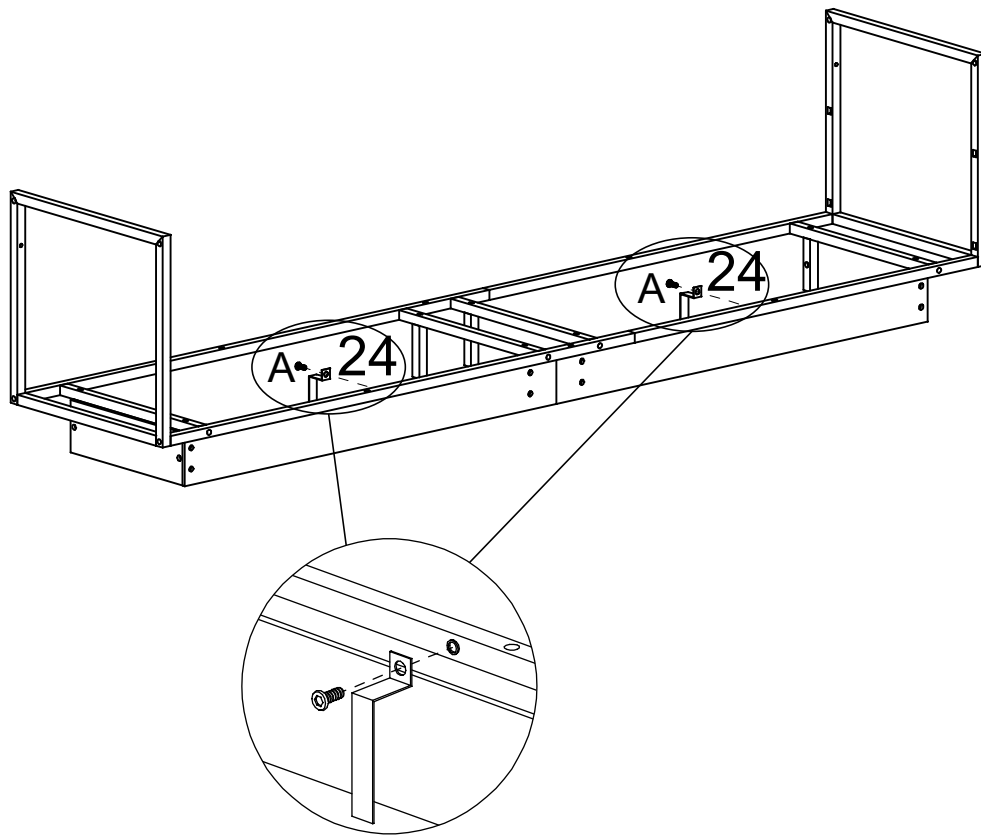

A	M6X10	X2
---	-------	----

Step 8

Outward-facing

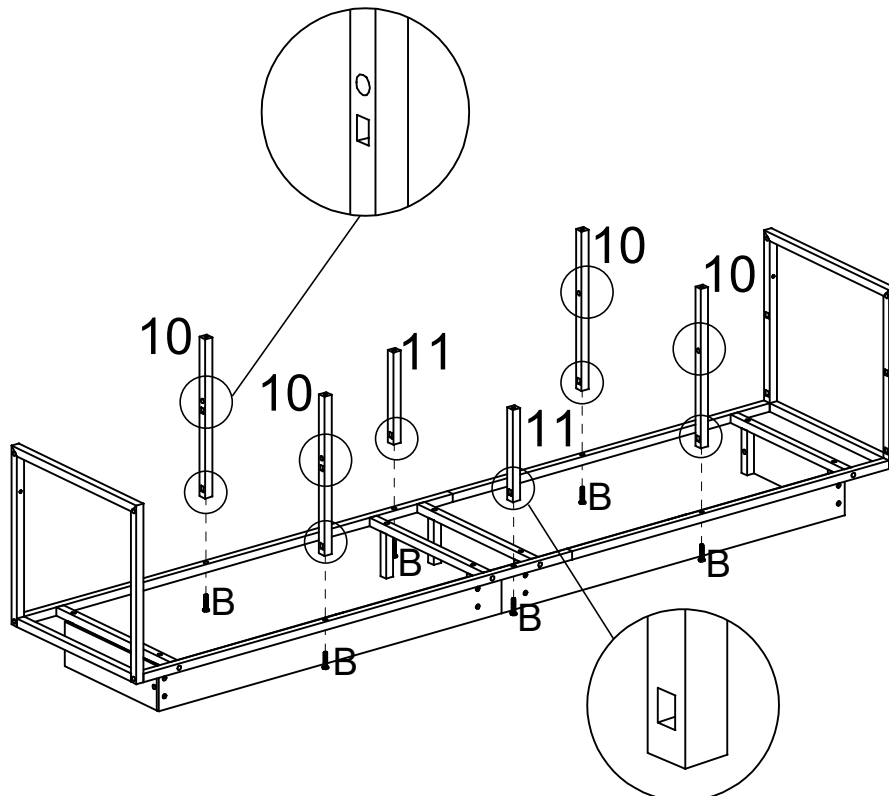

The rectangular hole closer to the edge of the steel pipe faces downwards.

B	M6X22	X6
---	-------	----

Step 9

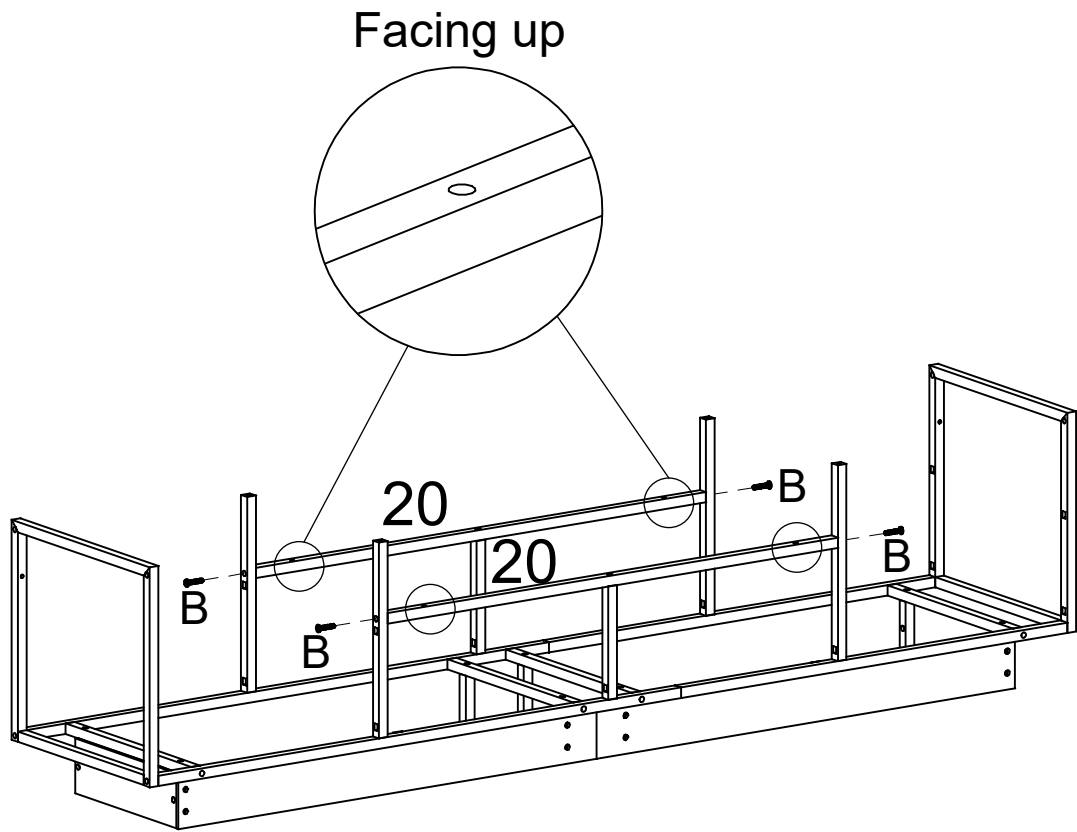

B	M6X22	X4
---	-------	----

Step 10

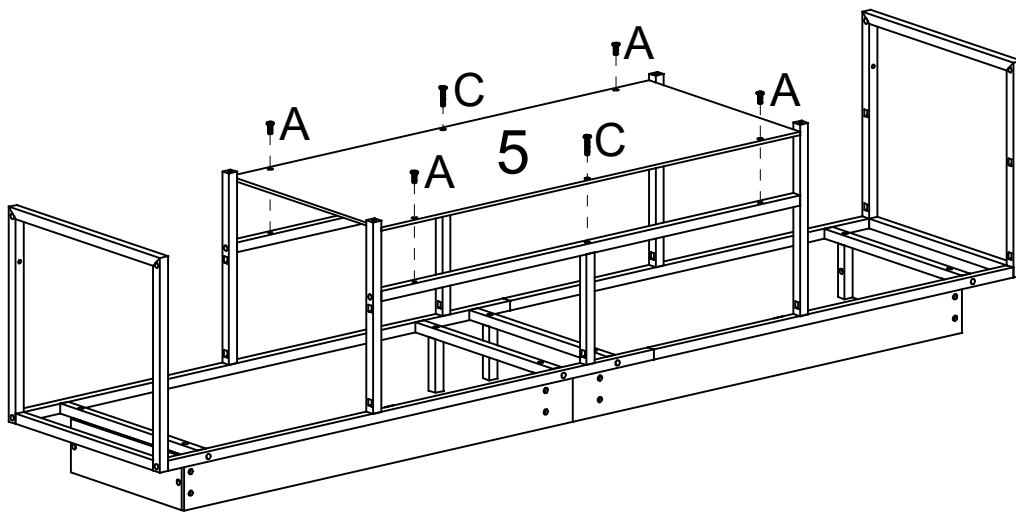

A	M6X10	X4
C	M6X28	X2

Step 11

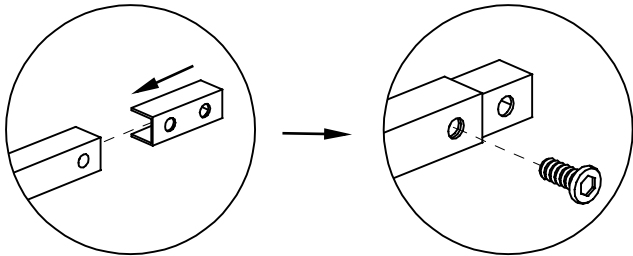
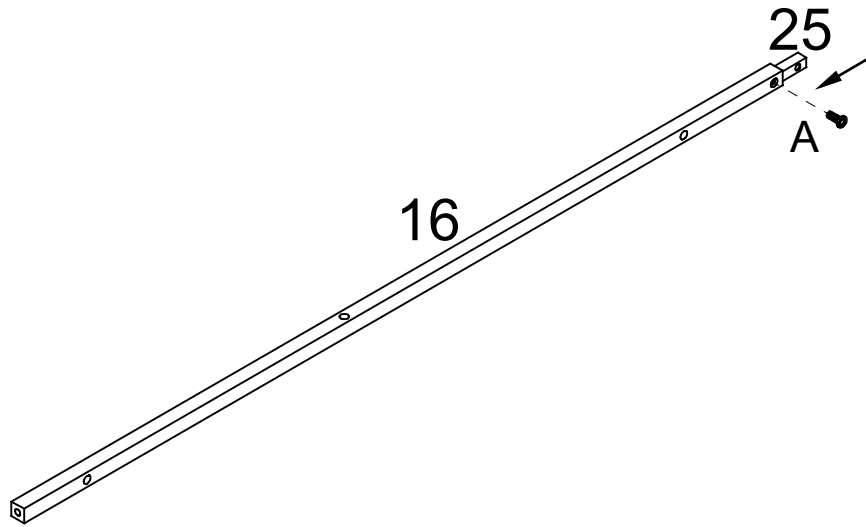

X2

A	M6X10	X2
---	-------	----

Step 12

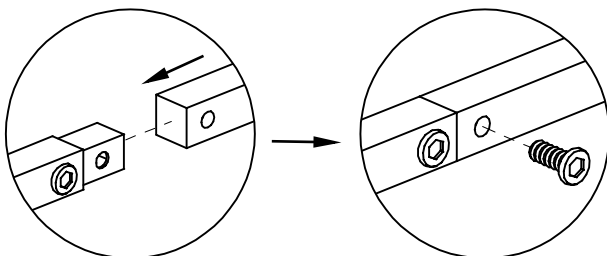
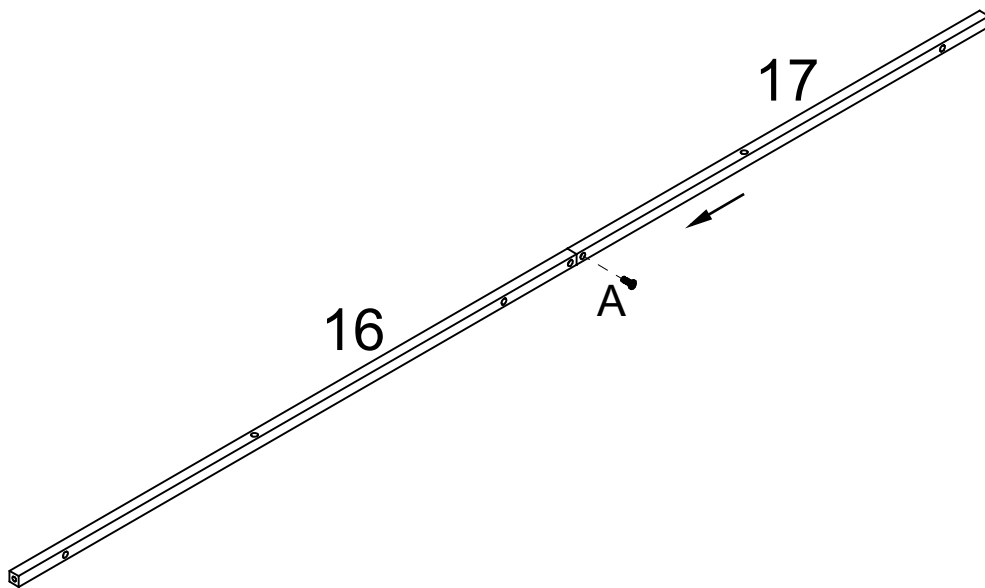

X2

A	M6X10	X2
---	-------	----

Step 13

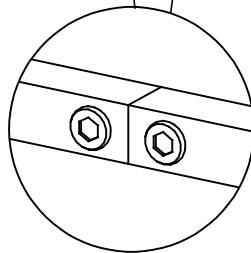
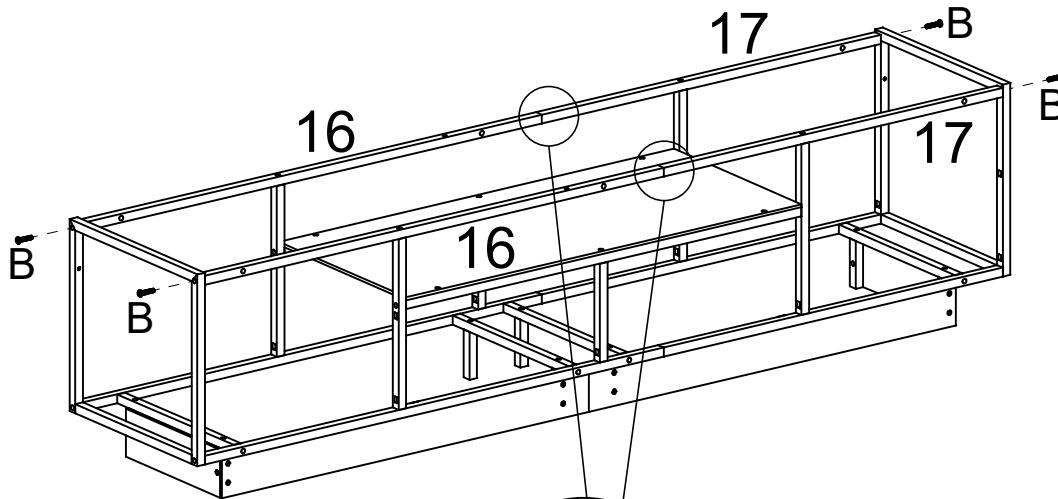

Backward



Pay attention to the number and tube orientation

B	M6X22	X4
---	-------	----

Step 14

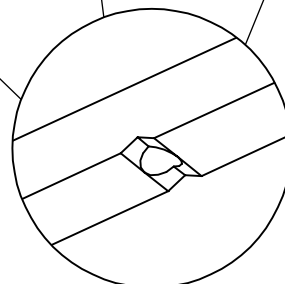
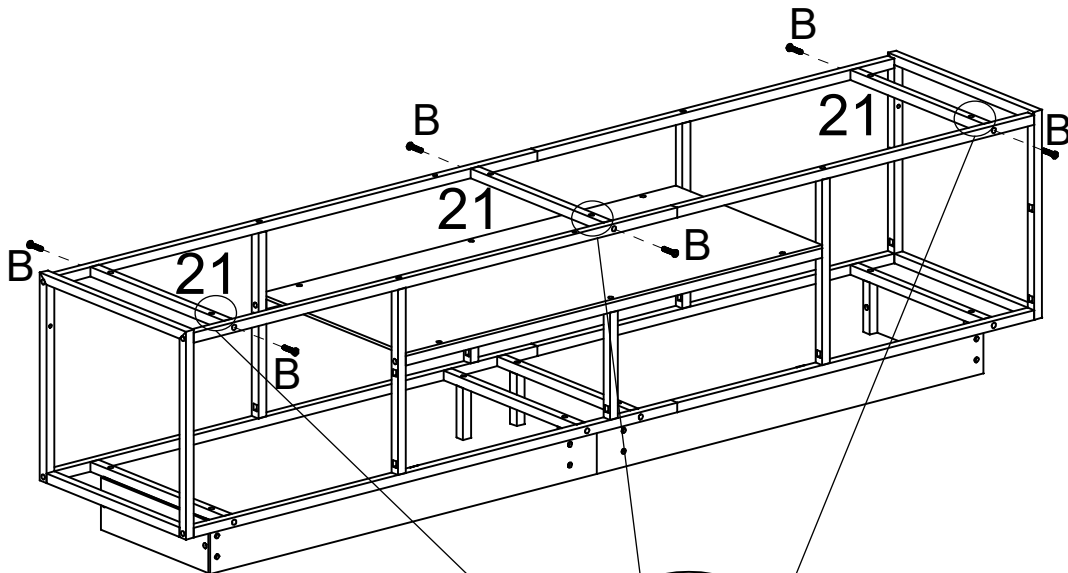

Facing down

B	M6X22	X6
---	-------	----

Step 15

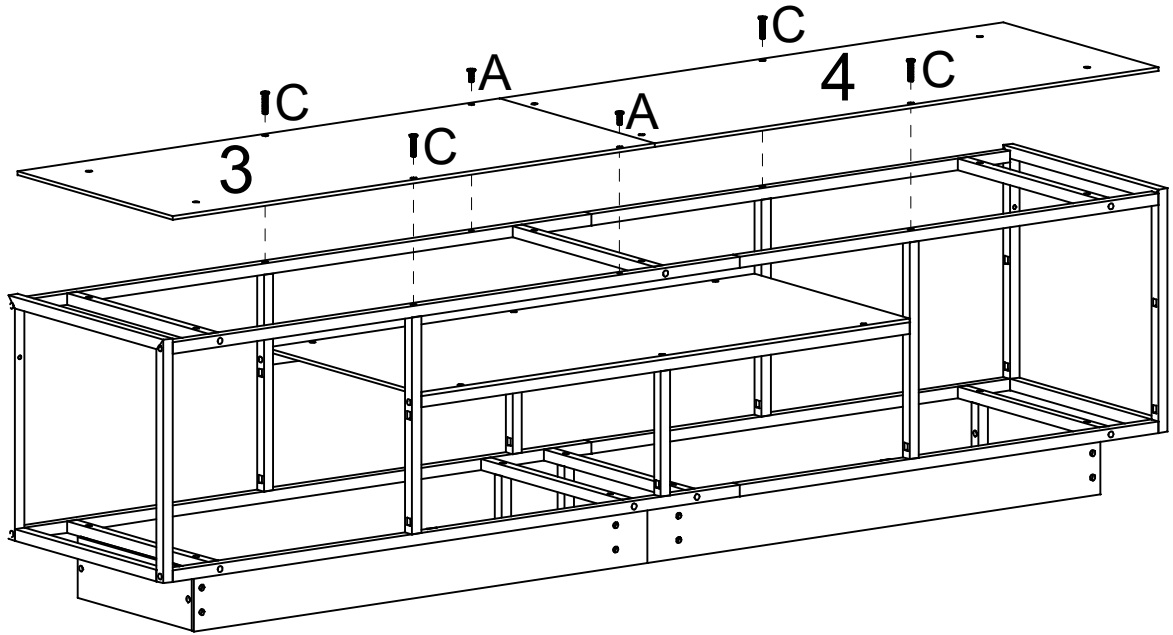

A	M6X10	X2
C	M6X28	X4

Step 16

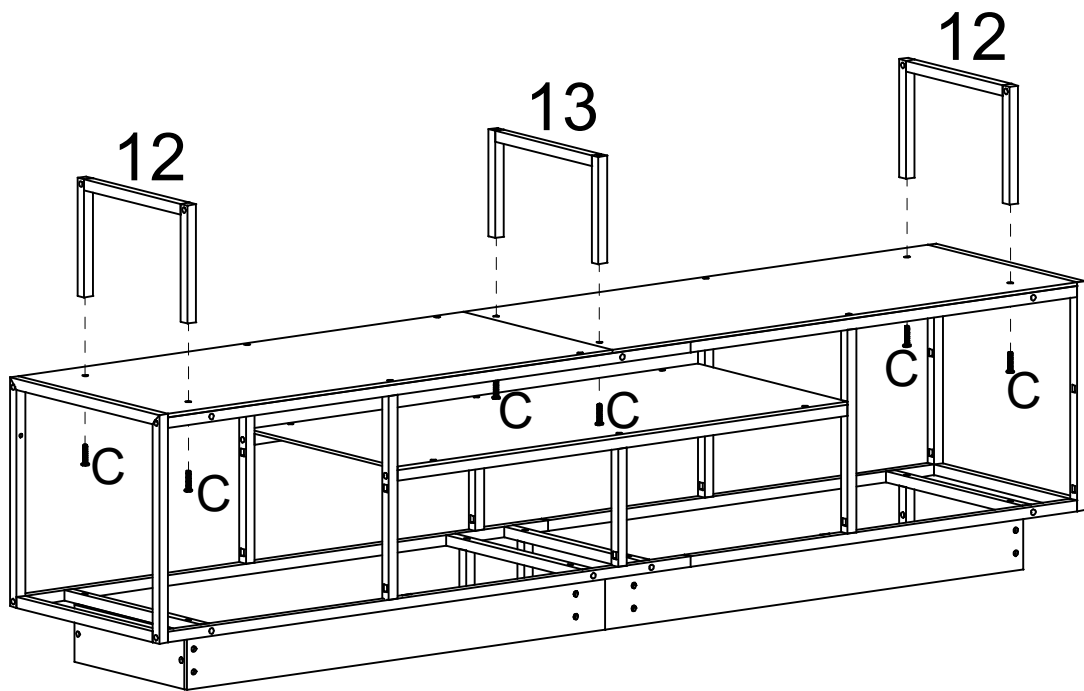

C	M6X28	X6
---	-------	----

Step 17

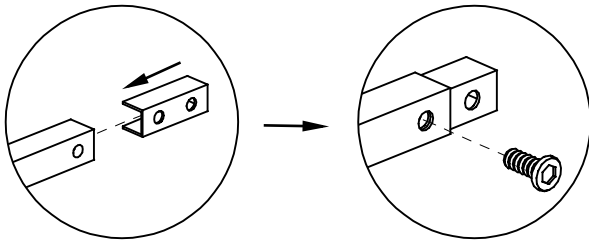
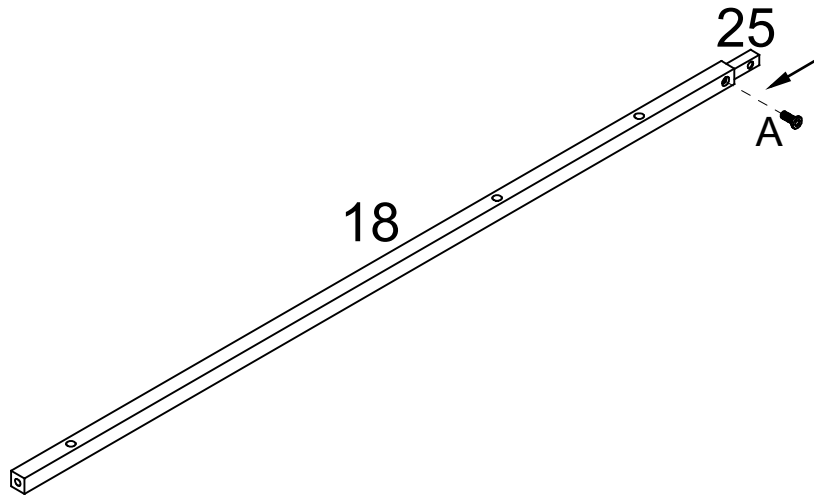

X2

A	M6X10	X2
---	-------	----

Step 18

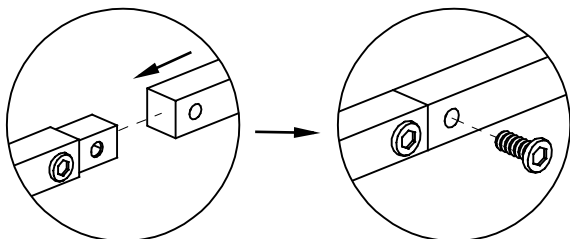
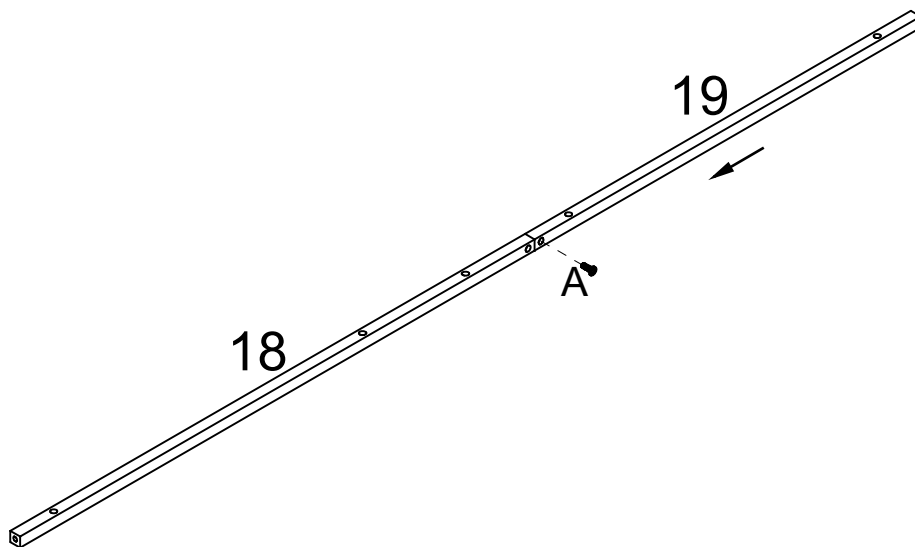

X2

A	M6X10	X2
---	-------	----

Step 19

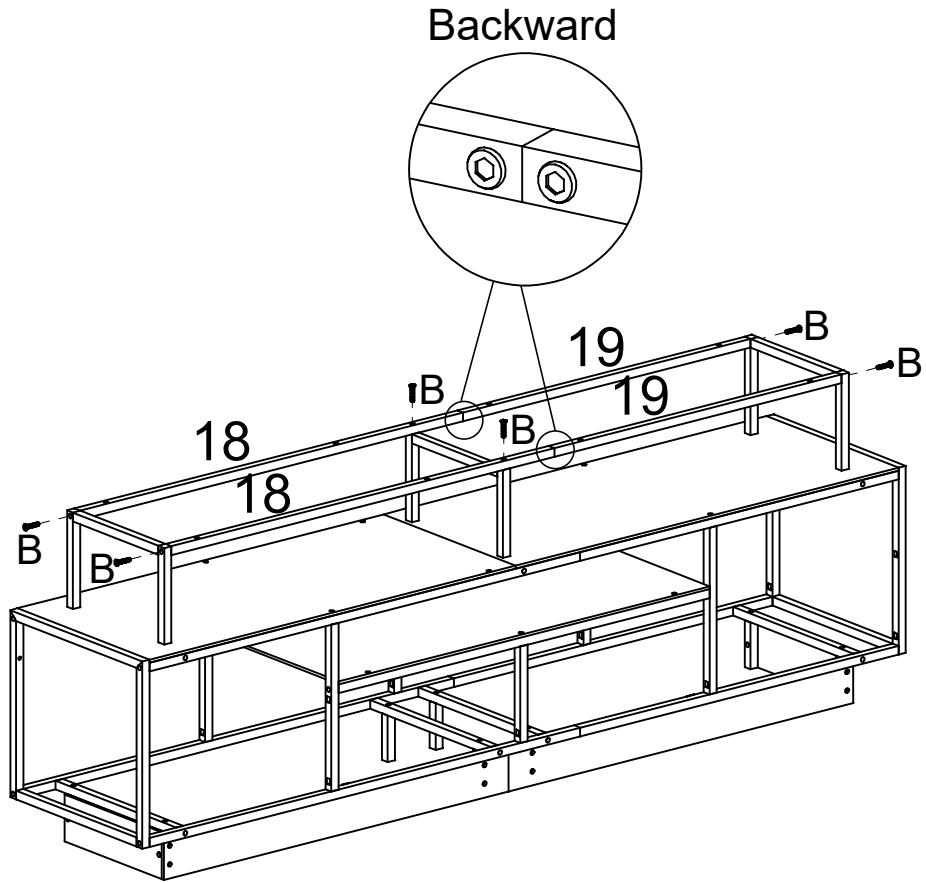

B	M6X22	X6
---	-------	----

Step 20

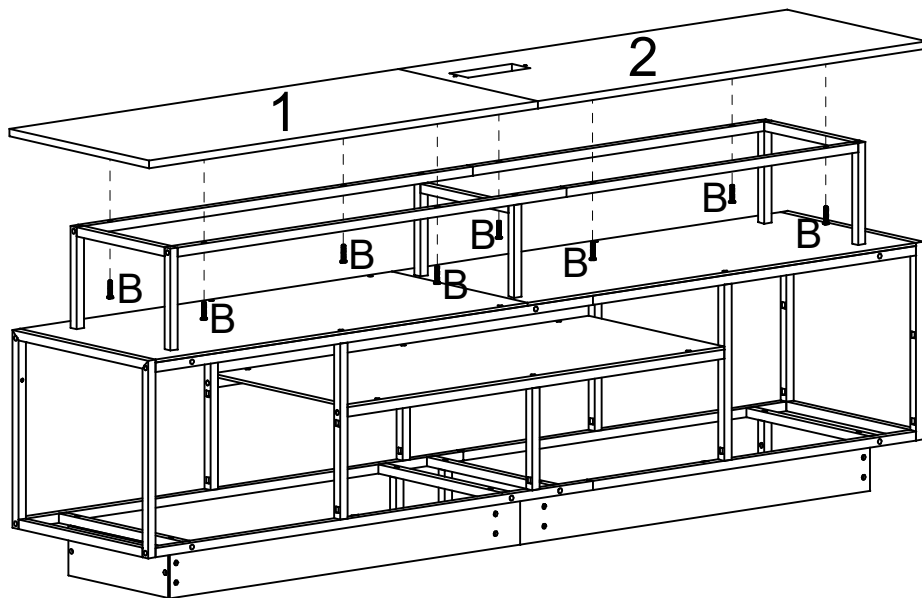

B	M6X22	X8
---	-------	----

Step 21

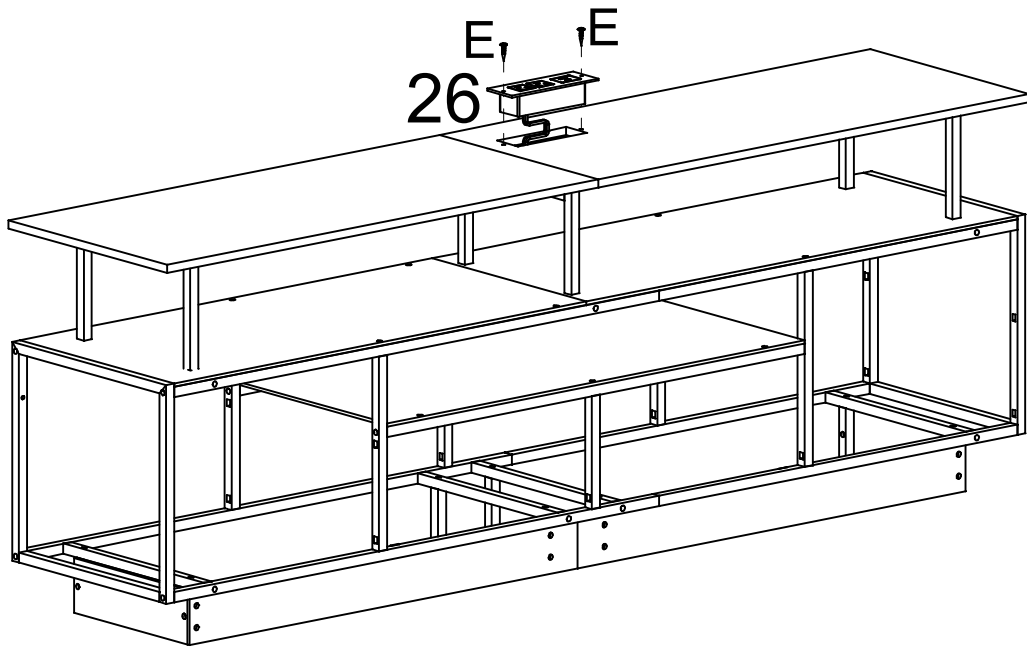

E	M4X12	X2
---	-------	----

Step 22

Rip the protective paper

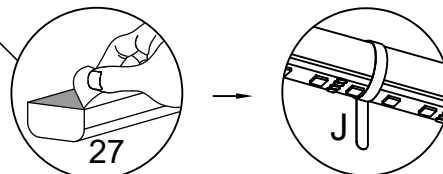
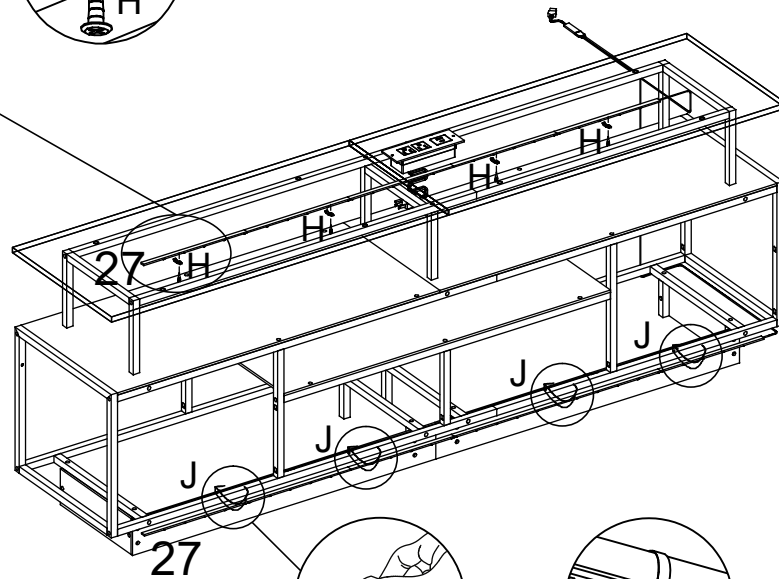
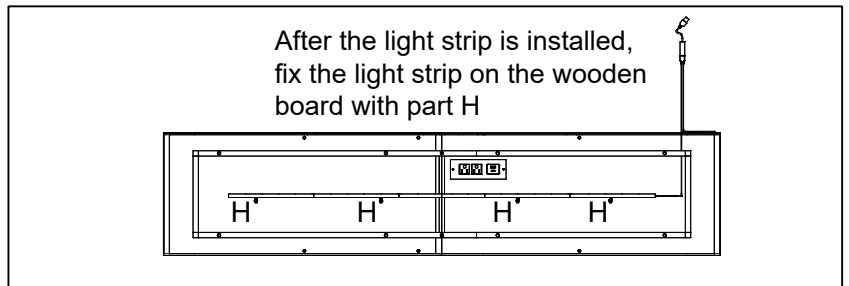
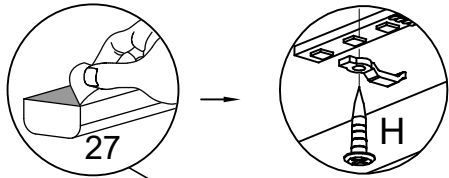

H		X4
J		X4

Step 23

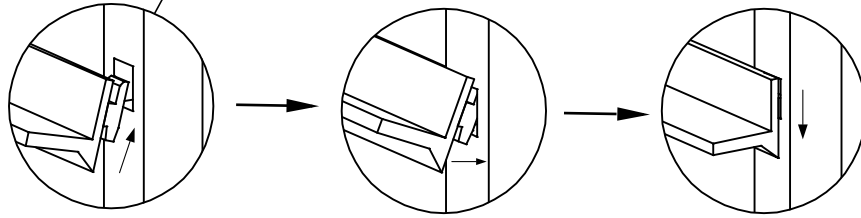
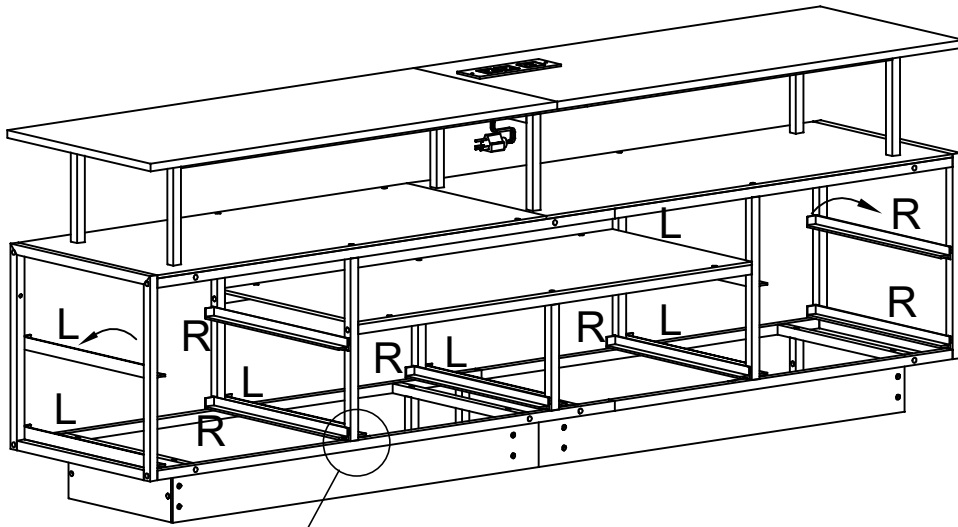

L		X6
R		X6

Step 24

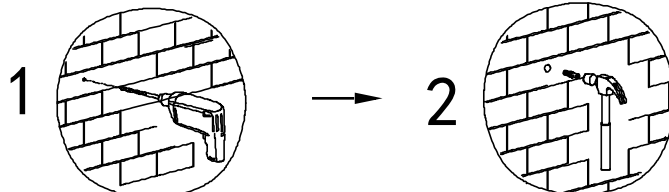
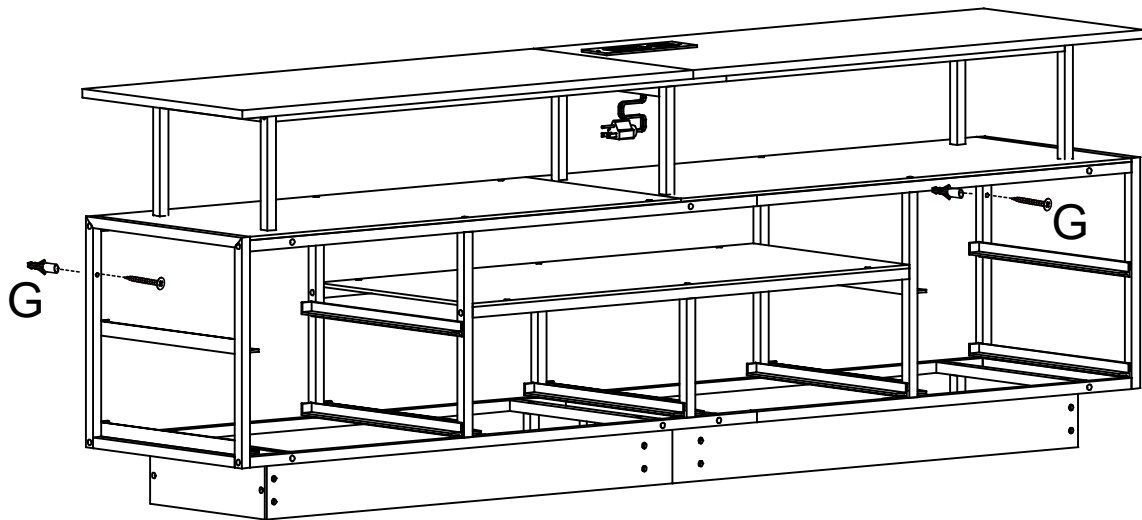

G		X2
---	--	----

Step 25

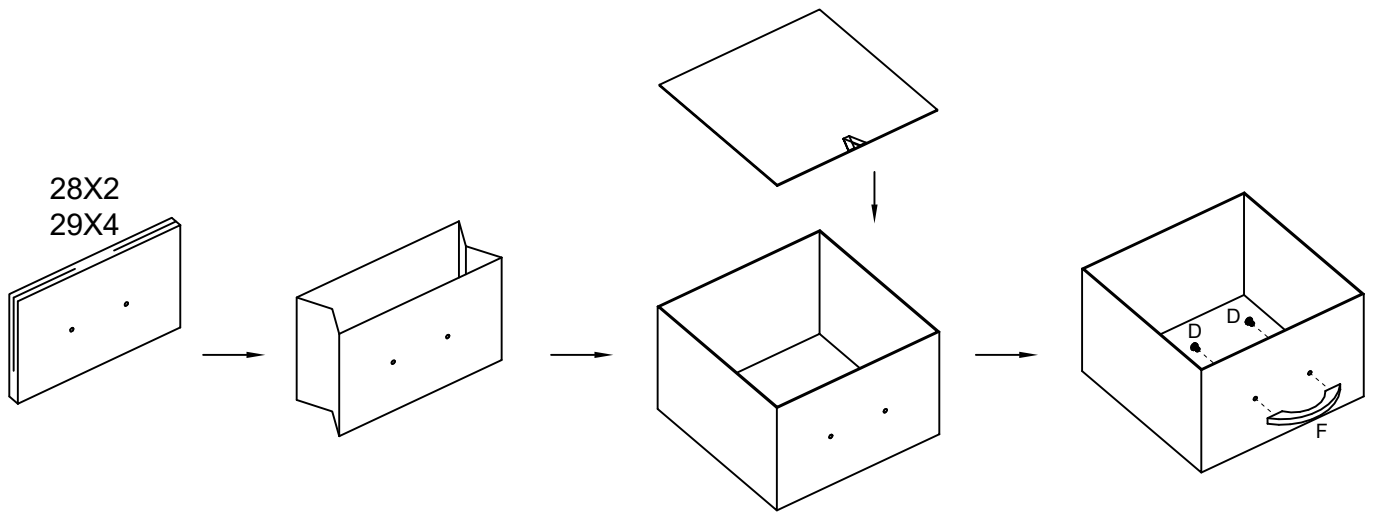

D	M4X10	X12
F		X6

