



**MONDAWE**  
PICK YOUR FAVORITE

Website: [www.mondawe.com](http://www.mondawe.com)  
Customer Service: [service@mondawe.com](mailto:service@mondawe.com)  
Phone: 888-328-5111

Site Internet: [www.mondawe.com](http://www.mondawe.com)  
Email de Service Client: [service@mondawe.com](mailto:service@mondawe.com)  
Numéro de Téléphone: 888-328-5111



# **MOT1012076**

## **Assembly Instruction**

## **Instruction de montage**

### **10x12ft Promotional Steel Framed Galvanized Steel Roof Gazebo**

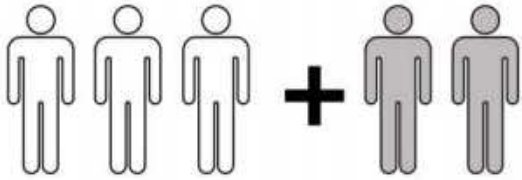

**EN:** Three or more people are required for assembly

**FR:** Trois personnes ou plus sont nécessaires pour l'assemblage

**EN:** The following tools are not included and needed for assembly

**FR:** Les outils suivants ne sont pas inclus et nécessaires pour l'assemblage

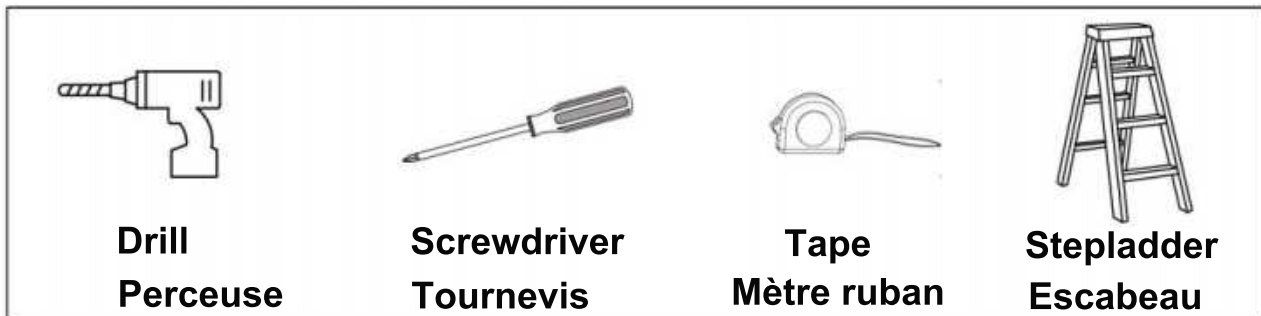

**EN:** Note:

1. The gazebo come with 3 carton boxes.
2. Wearing protective gloves is recommended.
3. Do not fully tighten screws prior to complete assembly.







**FR:** Avis:

1. Le gazebo est livré avec 3 boîtes en carton.
2. Le port de gants de protection est recommandé.
3. Ne serrez pas complètement les vis avant de terminer l'assemblage.

**EN**









## Before You Start

-  Please read all instructions carefully.
-  Retain instructions for future reference.
-  Separate and count all parts and hardware.
-  Read through each step carefully and follow the proper order.
-  We recommend that, where possible, all items are assembled near to the area in which they will be placed in use, to avoid moving the product unnecessarily once assembled.
-  Always place the product on a flat, steady and stable surface.
-  Keep all small parts and packaging materials for this product away from babies and children as they potentially pose a serious choking hazard.









**FR**













## Avant de Commencer

-  Veuillez lire attentivement toutes les instructions.
-  Conservez les instructions pour vous y référer ultérieurement.
-  Vérifiez toutes les pièces et les accessoires.
-  Lisez attentivement chaque étape et suivez l'ordre correct.
-  Nous recommandons que, dans la mesure du possible, tous les produits soient assemblés à proximité de la zone où ils seront utilisés, afin d'éviter tout déplacement inutile du produit une fois assemblé.
-  Placez toujours le produit sur une surface plane et stable.
-  Conservez toutes les petites pièces de ce produit et les matériaux d'emballage hors de portée des bébés et des enfants, car ils pourraient présenter un risque d'étouffement.









## PARTS LIST ( Carton Box -1)

A2	G2	C1
 Post	 Long slant beam	 Left beam of short side
4PCS	4PCS	2PCS
C2	D1	D2
 Right beam of short side	 Left beam of long side	 Right beam of long side
2PCS	2PCS	2PCS
S2	F2	R1
 Long slant beam cover	 Inner bracket	 Press panel
4PCS	4PCS	28PCS







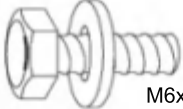

## HARDWARE LIST

II	GG	TT
 M6x15 Outer Hex head bolt & Washer	 Washer & Nut	 M6x15 Inner Hex head screw & Washer
16+2PCS	2PCS	156+15PCS
HH	WW	UU
 M6x15 Inner Hex head bolt & Washer	 M6x20 Bolt	 ø6x200 Stake
52+5PCS	16+2PCS	12PCS
Z1	Z5	Z4
 M6 Wrench	 M6 Allen key	 M8 Allen key
2PCS	2PCS	2PCS
N1		
 Hook		
1PC		

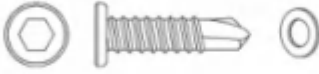





















## Liste des pièces(Boîte en carton 1)

<p><b>A2</b></p>  <p>Poteau</p>	<p><b>G2</b></p>  <p>Poutre biseau longue</p>	<p><b>C1</b></p>  <p>Poutre gauche du côté court</p>
<p>4X</p>	<p>4X</p>	<p>2X</p>
<p><b>C2</b></p>  <p>Poutre droit du côté court</p>	<p><b>D1</b></p>  <p>Poutre gauche de côté long</p>	<p><b>D2</b></p>  <p>Poutre droit de côté long</p>
<p>2X</p>	<p>2X</p>	<p>2X</p>
<p><b>S2</b></p>  <p>Plaque de couverture de poutre biseau longue</p>	<p><b>F2</b></p>  <p>Support intérieur</p>	<p><b>R1</b></p>  <p>Panel de presse</p>
<p>4X</p>	<p>4X</p>	<p>28X</p>















## Liste des quincaillerie

<p><b>II</b></p>  <p>M6x15 Boulon de tête hexagonal extérieur &amp; Rondelle</p>	<p><b>GG</b></p>  <p>Rondelle &amp; Écrou</p>	<p><b>TT</b></p>  <p>M6x15 Vis à tête hexagonale interne &amp; Rondelle</p>
<p>16+2X</p>	<p>2X</p>	<p>156+15X</p>
<p><b>HH</b></p>  <p>M6x15 Boulon de tête hexagonal intérieur &amp; Rondelle</p>	<p><b>WW</b></p>  <p>M6x20 Boulon</p>	<p><b>UU</b></p>  <p>ø6x200 Piquet</p>
<p>52+5X</p>	<p>16+2X</p>	<p>12X</p>
<p><b>Z1</b></p>  <p>M6 Clef de tête hexagonal extérieur</p>	<p><b>Z5</b></p>  <p>M6 Clef de tête hexagonal intérieur</p>	<p><b>Z4</b></p>  <p>M8 Clef de tête hexagonal intérieur</p>
<p>2X</p>	<p>2X</p>	<p>2X</p>
<p><b>N1</b></p>  <p>Hook</p>		
<p>1X</p>		

## PARTS LIST ( Carton Box -2)

<b>B3</b>  Base	<b>E1</b>  Long curtain bar	<b>E2</b>  Short curtain bar
4PCS	4PCS	4PCS
<b>F5</b>  Corner cover	<b>Z</b>  Corner inner bracket	<b>H2</b>  Big roof middle beam
4PCS	4PCS	4PCS
<b>X3</b>  Left support	<b>X4</b>  Right support	<b>J1</b>  Big roof short side tube
4PCS	4PCS	2PCS
<b>J2</b>  Big roof long side tube	<b>K1</b>  Big roof upper short tube	<b>K2</b>  Big roof upper long tube
2PCS	4PCS	4PCS
<b>F3</b>  Big roof lower short tube 1	<b>F4</b>  Big roof lower short tube 2	<b>K5</b>  Big roof lower long tube 1
2PCS	2PCS	2PCS
<b>K6</b>  Big roof lower long tube 2	<b>L1</b>  Small roof slant beam	<b>M1</b>  Small roof connector
2PCS	4PCS	1PC
<b>S1</b>  Small roof side cover	<b>P1</b>  Small roof cover	<b>Q1</b>  Small roof short tube
4PCS	1PC	2PCS
<b>Q2</b>  Small roof long tube		
2PCS		

## Liste des pièces(Boîte en carton 2)

<b>B3</b>  Base	<b>E1</b>  Barre à rideau longue	<b>E2</b>  Barre à rideau court
4X	4X	4X
<b>F5</b>  Couvercle d'angle	<b>Z</b>  Support intérieur d'angle	<b>H2</b>  Poutre supérieure centrale
4X	4X	4X
<b>X3</b>  Support de gauche	<b>X4</b>  Support de droite	<b>J1</b>  Tube latéral court de grand toit
4X	4X	2X
<b>J2</b>  Long tube latéral de grand toit	<b>K1</b>  Tube court supérieur de grand toit	<b>K2</b>  Long tube supérieur de grand toit
2X	4X	4X
<b>F3</b>  Tube court inférieur de grand toit 1	<b>F4</b>  Tube court inférieur de grand toit 2	<b>K5</b>  Long tube inférieur de grand toit 1
2X	2X	2X
<b>K6</b>  Long tube inférieur de grand toit 2	<b>L1</b>  Poutre biseau de petit toit	<b>M1</b>  Connecteur central de petit toit
2X	4X	1X
<b>S1</b>  Plaque de couverture latérale de petit toit	<b>P1</b>  Couverture centrale d'un petit toit	<b>Q1</b>  Court tube de petit toit
4X	1X	2X
<b>Q2</b>  Long tube de petit toit		
2X		

## PARTS LIST ( Carton Box -3)

T1

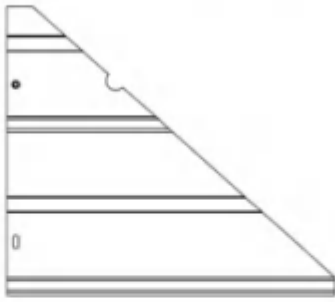

Left small cover plate

8PCS

T2

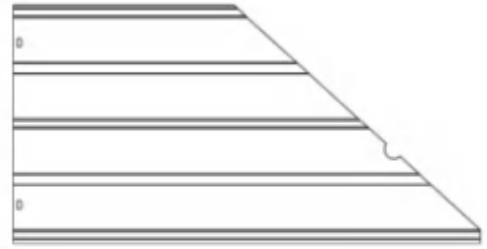

Big roof left cover plate

4PCS

T3

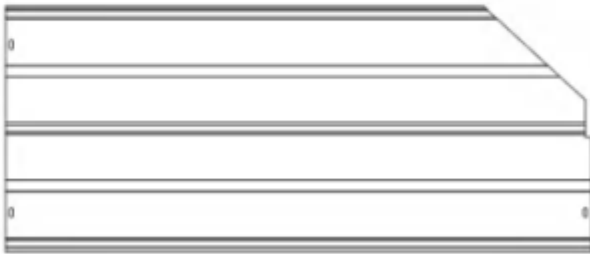

Big roof left middle big cover plate

4PCS

T4

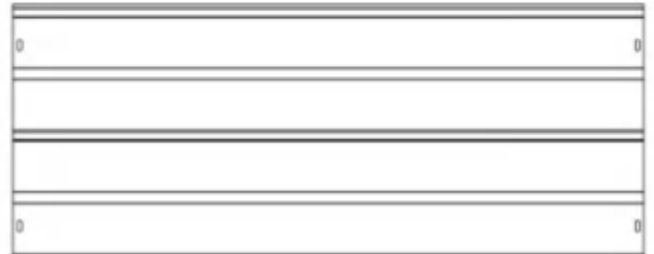

Big roof middle big cover plate

2PCS

T5

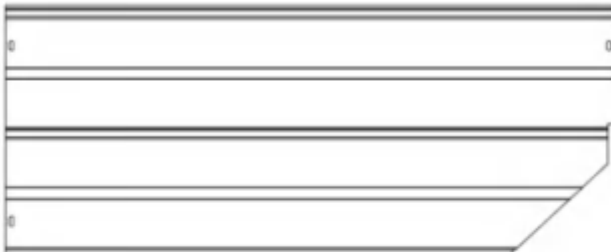

Big roof right middle big cover plate

4PCS

T6

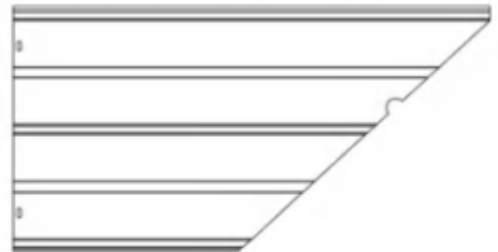

Big roof right cover plate

4PCS

T7

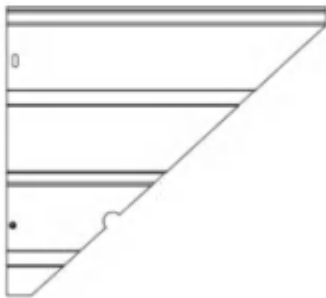

Right small cover plate

8PCS

T8



Small roof middle cover plate

2PCS

## Liste des pièces(Boîte en carton 3)

T1

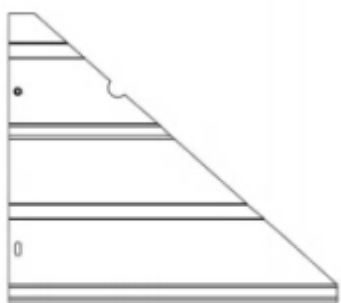

Petite plaque de couverture gauche

8X

T2

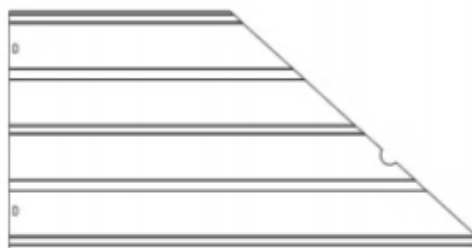

Plaque de couverture gauche de grand toit

4X

T3

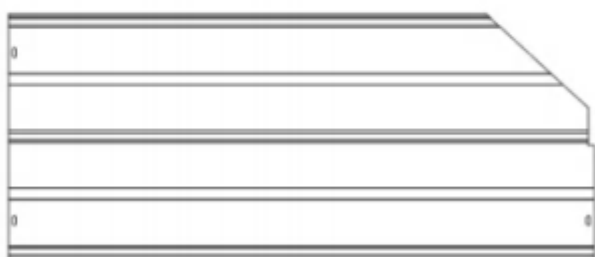

Milieu gauche grande plaque de couverture de grand toit

4X

T4

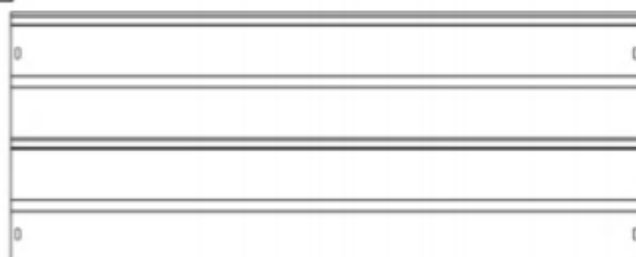

Moyenne grande plaque de couverture de grand toit

2X

T5

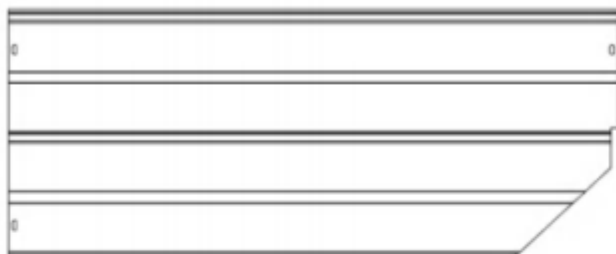

Milieu droit grande plaque de couverture de grand toit

4X

T6

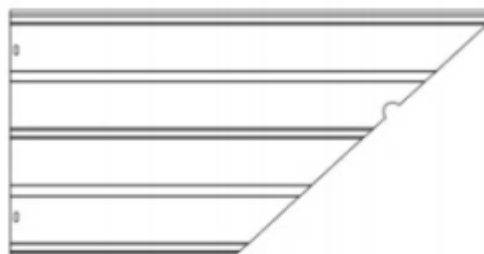

Plaque de couverture droite de grand toit

4X

T7

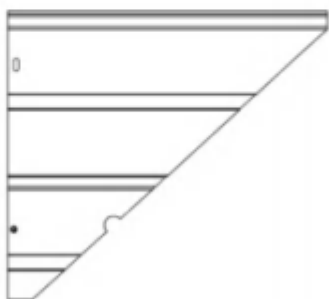

Petite plaque de couverture droite

8X

T8

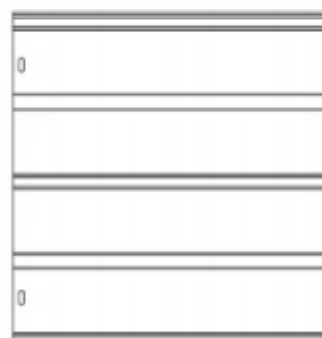

Plaque de couverture centrale de petit toit

2X

# Exploded Views

## Vue éclatées

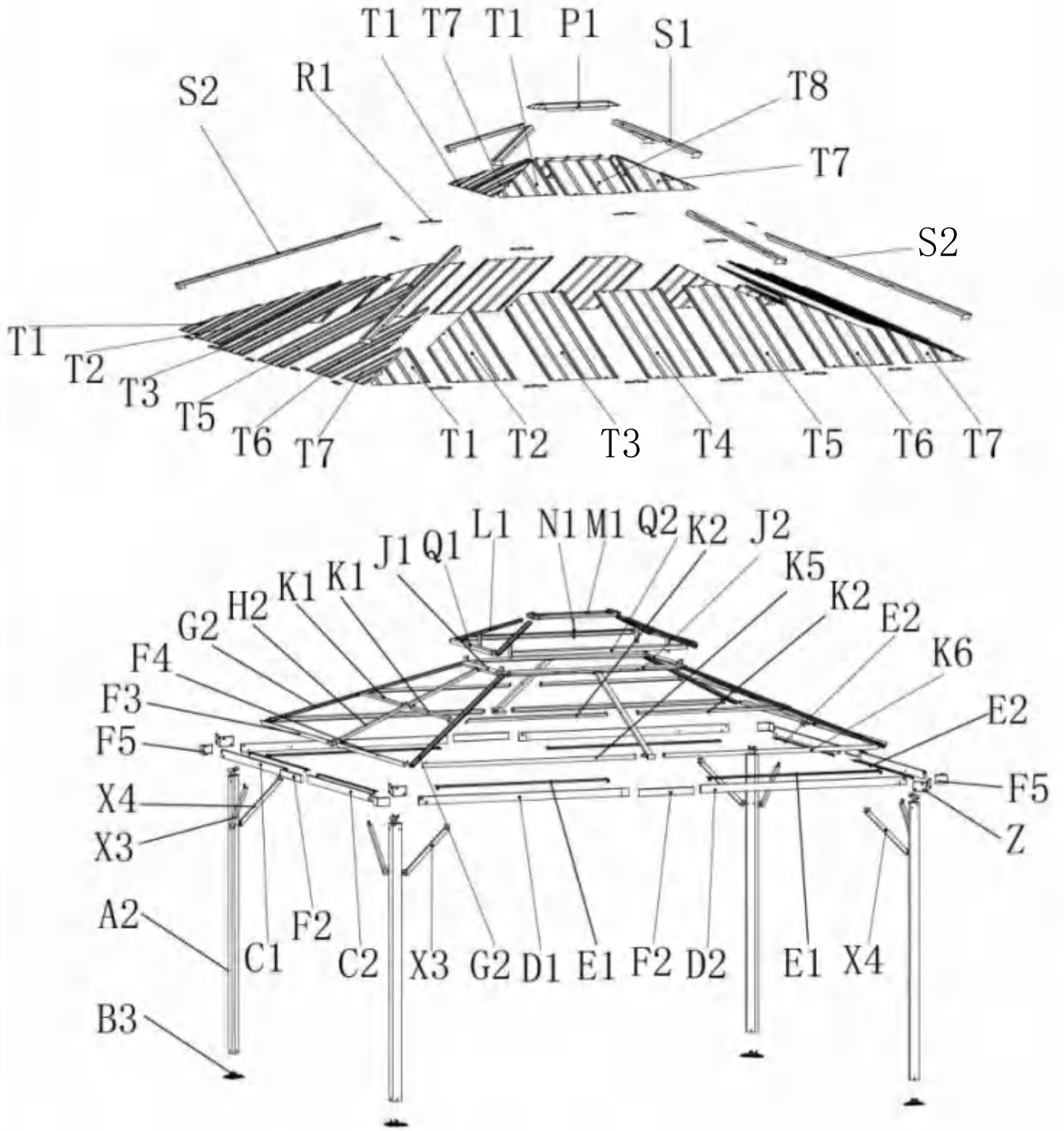

<1>

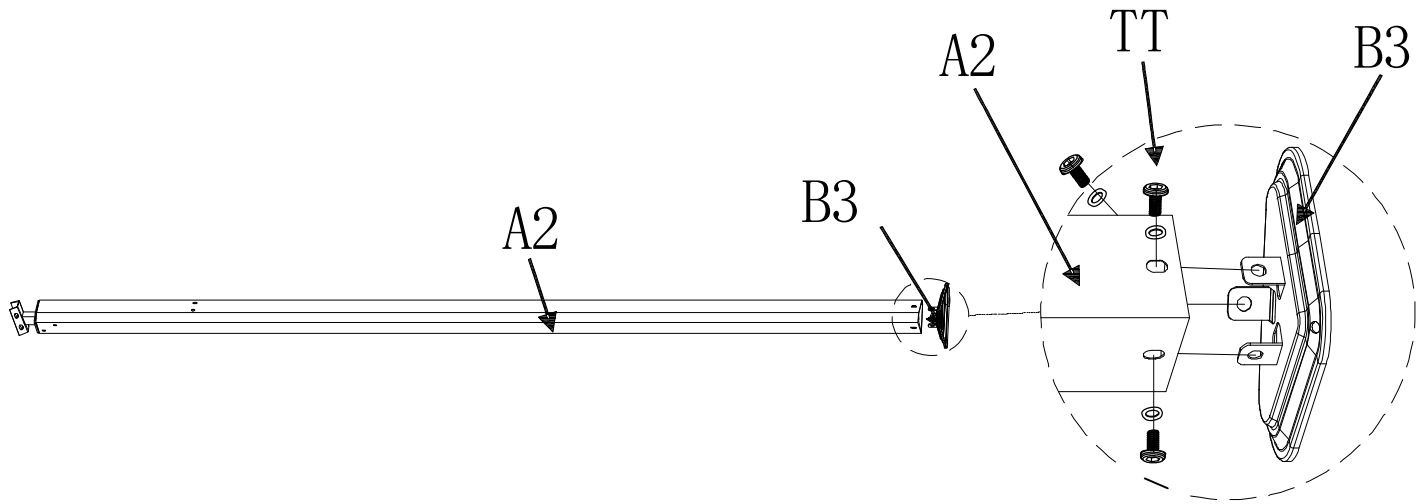

**EN:** Set up poles A2 with bases B3 by using screws TT, please preinstall three screws first, then tighten up them.

**FR:** Configurez les pôles A2 avec les bases B3 avec les vis TT, veuillez d'abord préinstaller trois vis, puis les verrouiller.

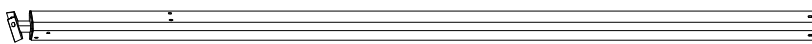

Ⓐ 4X

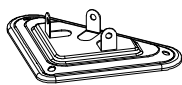

Ⓑ 4X

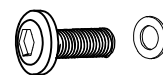

M6\*15

Ⓓ 12X

# <2>

**EN:** Connect 2 sets of beams C1&C2 with inner brackets F2 by using screws TT.

**FR:** Connectez 2 jeux de poutres C1 et C2 avec supports intérieurs F2 avec les vis TT.

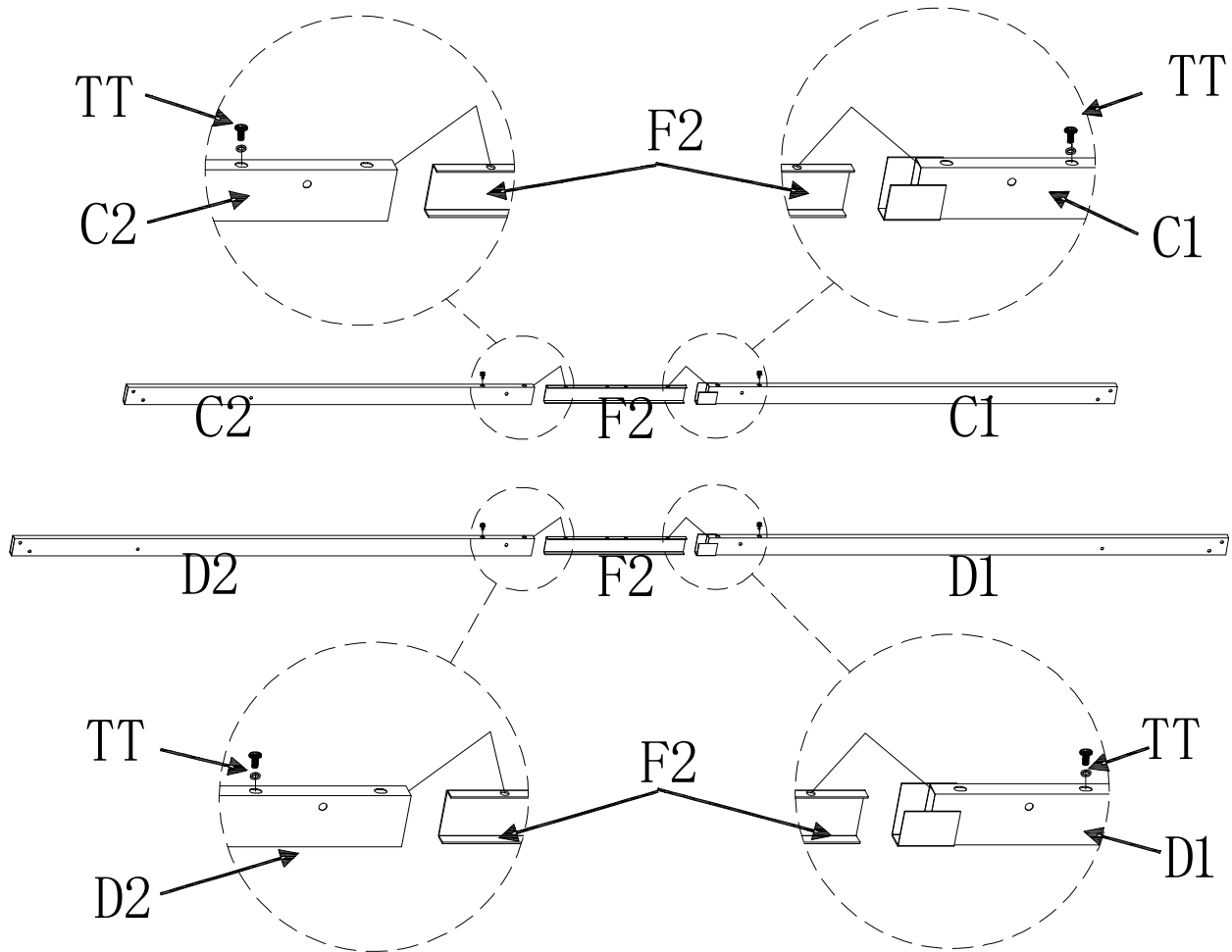

**EN:** Connect 2 sets of beams D1&D2 with inner brackets F2 by using screws TT.

**FR:** Connectez 2 jeux de poutres D1 et D2 avec supports intérieurs F2 avec les vis TT.

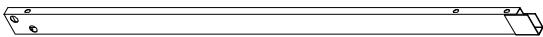

Ⓢ C1 2X

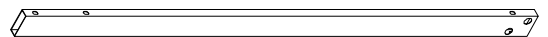

Ⓢ C2 2X

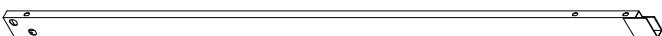

Ⓢ D1 2X



Ⓢ D2 2X

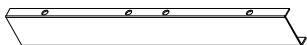

Ⓢ F2 4X

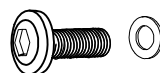

M6\*15

Ⓢ TT 8X

# <3>

**EN:** Attach the short curtain bars E2 to the beam C1/C2 using screws TT.  
**FR:** Fixez les courtes barres de rideau E2 à la poutre C1/C2 avec les vis TT.

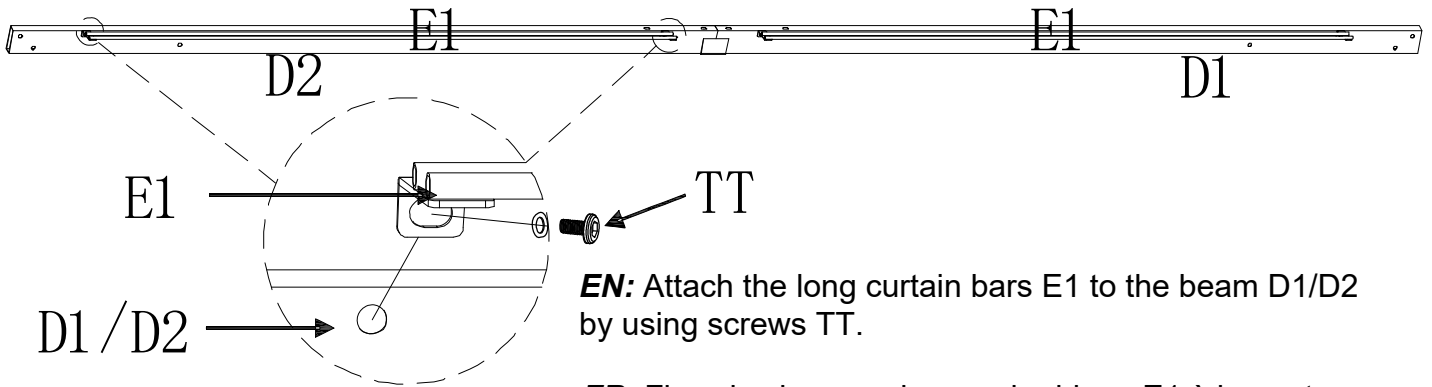
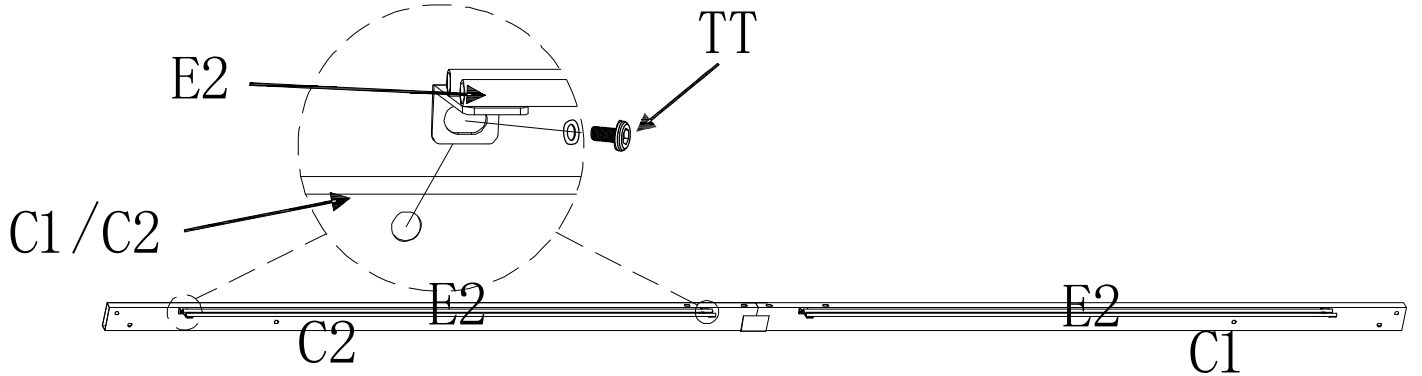

**EN:** Attach the long curtain bars E1 to the beam D1/D2 by using screws TT.

**FR:** Fixez les longues barres de rideau E1 à la poutre D1/D2 avec les vis TT.

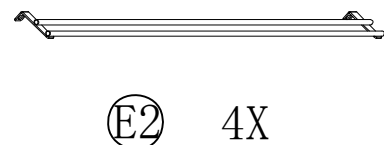
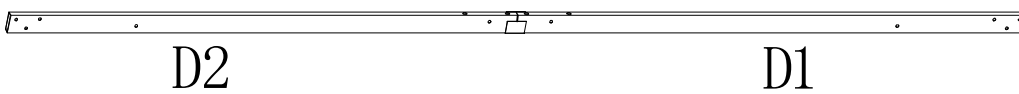
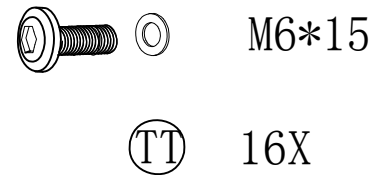
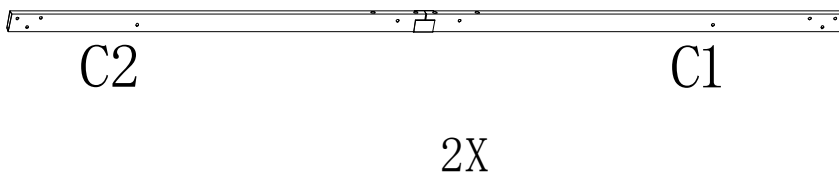

# <4>

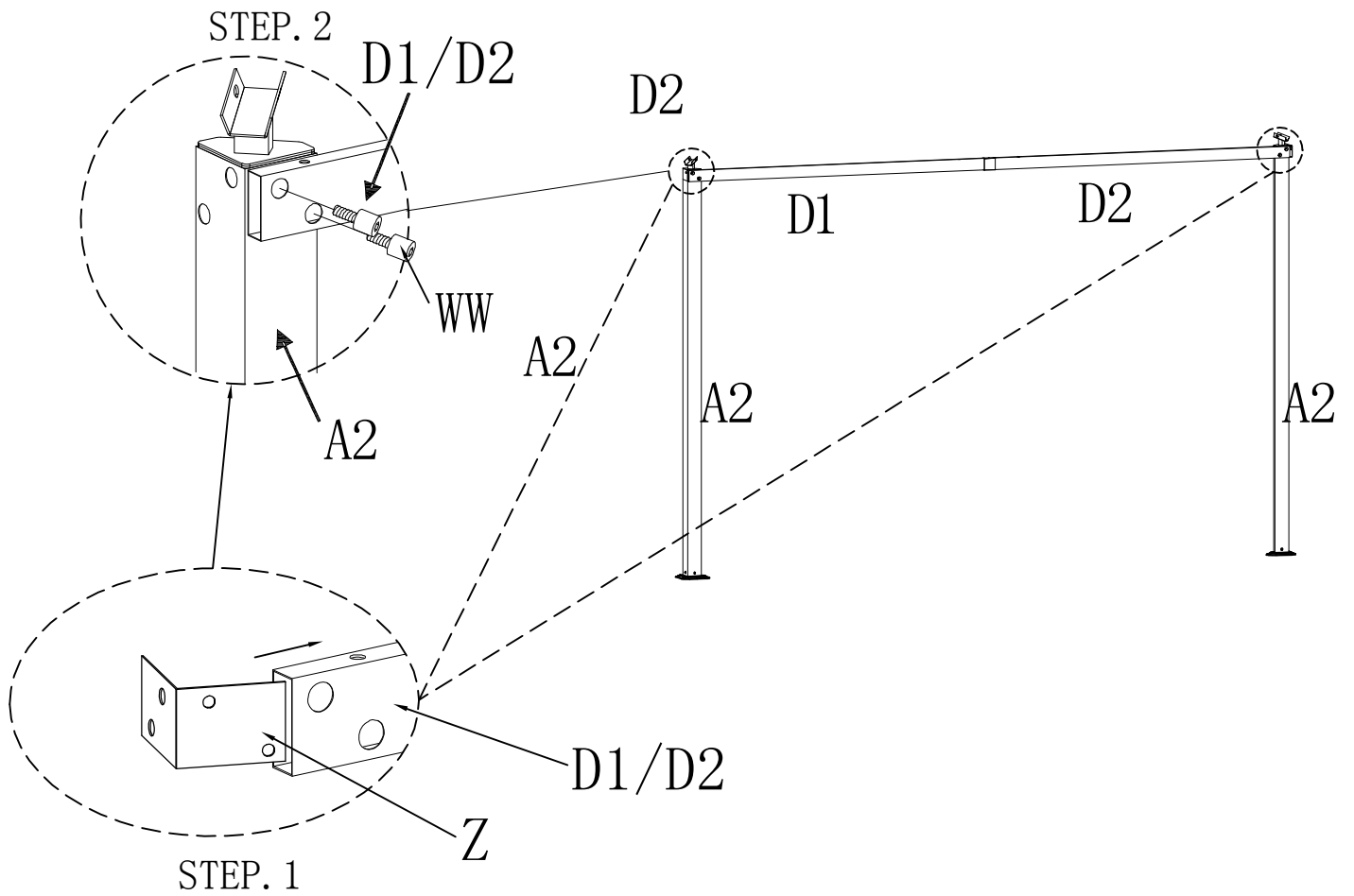

**EN:** Put the poles A2 falt on the ground,insert the corner inner bracket Z into assembled beam D1/D2 by using bolts WW.

**FR:** Posez les poteaux A2 falt sur le sol, insérer le support intérieur d'angle Z dans la poutre assemblée D1/D2 avec les boulons WW.

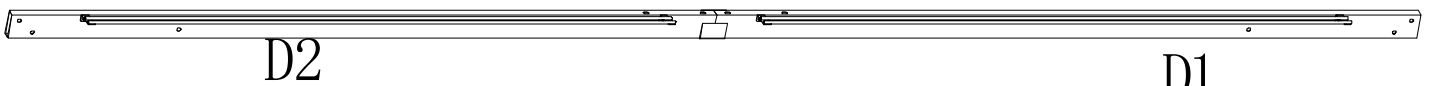

2X

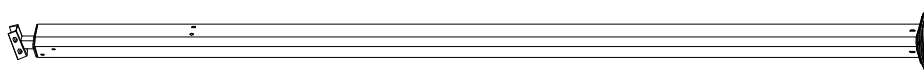

4X



WW

8X

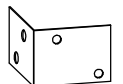

Z

4X

# <5>

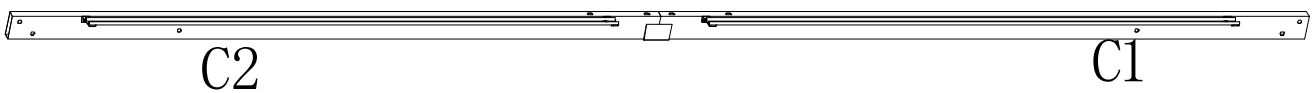
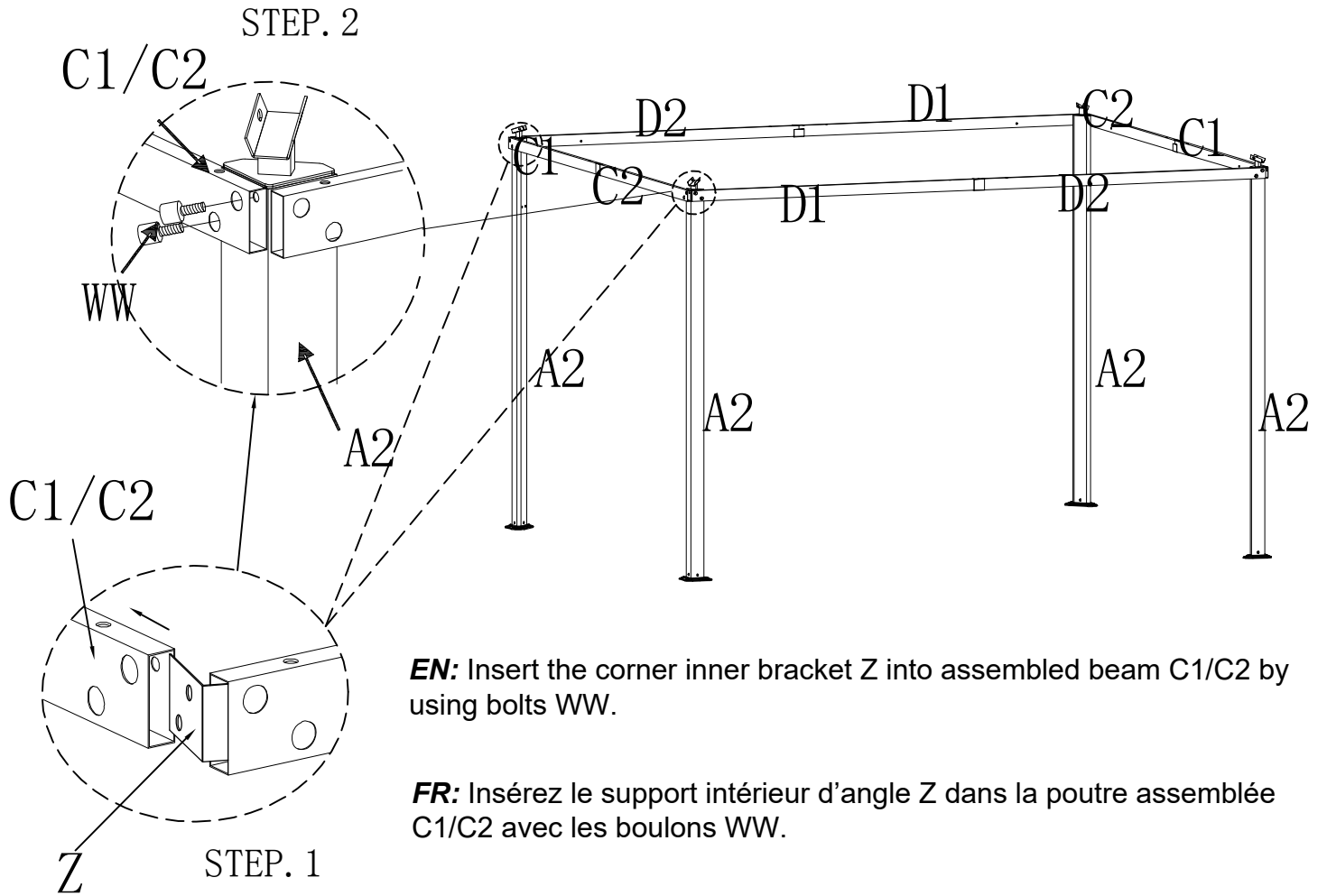

2X



8X

<6>

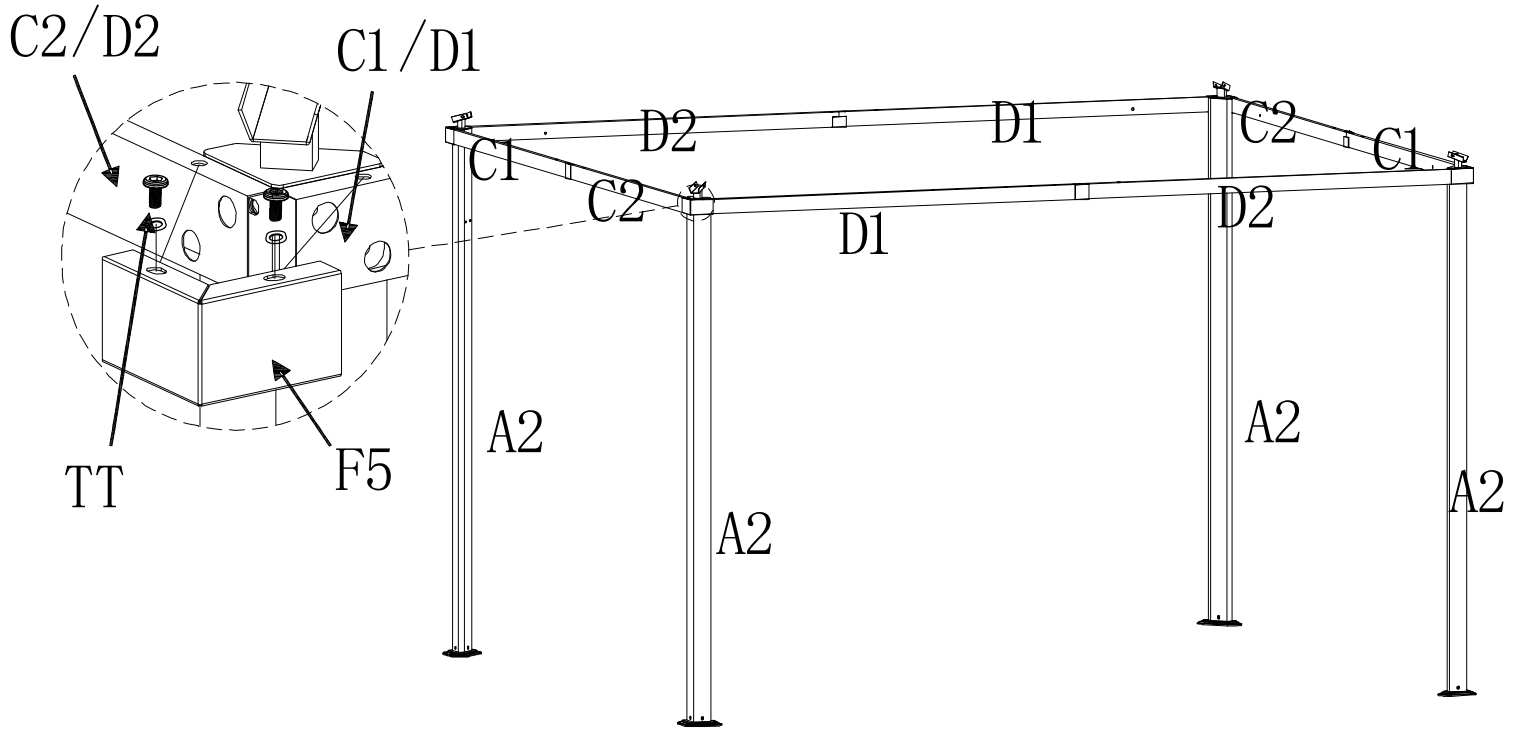

**EN:** Attach the corner covers F5 to assembled beams C1/D1/C2/D2 by using screws TT.

**FR:** Fixez les couvercles d'angle F5 aux poutres assemblées C1/D1/C2/D2 avec les vis TT.

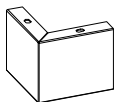

(F5) 4X

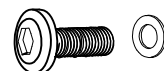

M6\*15

(TT) 8X

# <7>

**EN:** Required tape  
**FR:** Mètre ruban est nécessaire

**EN:** Attach top of Left/Right Support X3/X4 to assembled beam C1/C2/D1/D2 and attached the bottom of Left/Right Support X3/X4 to post A2 by using screws TT.

**FR:** Fixez le haut du support gauche/droit X3/X4 à la poutre assemblée C1/C2/D1/D2 et fixez le bas du support gauche/droit X3/X4 au poteau A2 avec les vis TT.

C1 / C2

D1 / D2

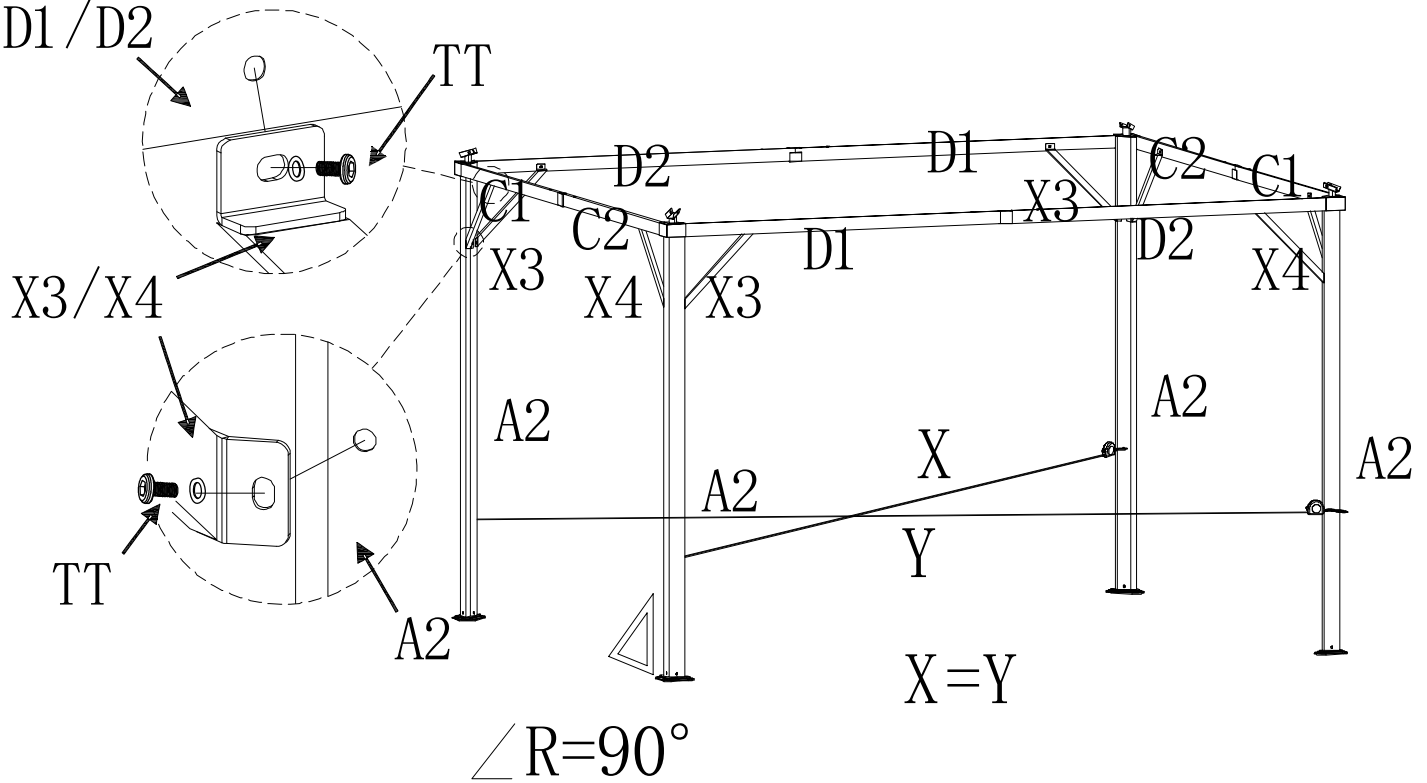

**EN:** Note: Make sure the distances are equal between two diagonals of posts by using tape before to next assemble step.

**FR:** Avis: Assurez-vous que les distances sont égales entre deux diagonales de poteaux en utilisant du ruban à mesurer avant l'étape suivante d'assemblage.

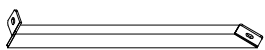

(X3) 4X

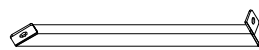

(X4) 4X

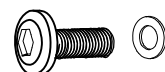

M6\*15

(TT)

16X

<8>

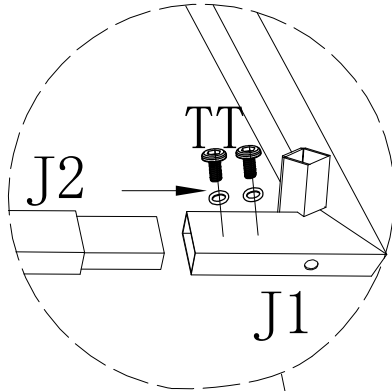

**EN:** Connect short side tubes of big roof J1 with the long side tubes of big roof J2 by using screws TT.

**FR:** Connectez les tubes latéraux courts du grand toit J1 avec les tubes latéraux longs du grand toit J2 avec les vis TT.

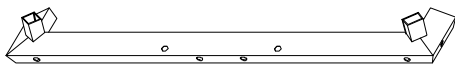
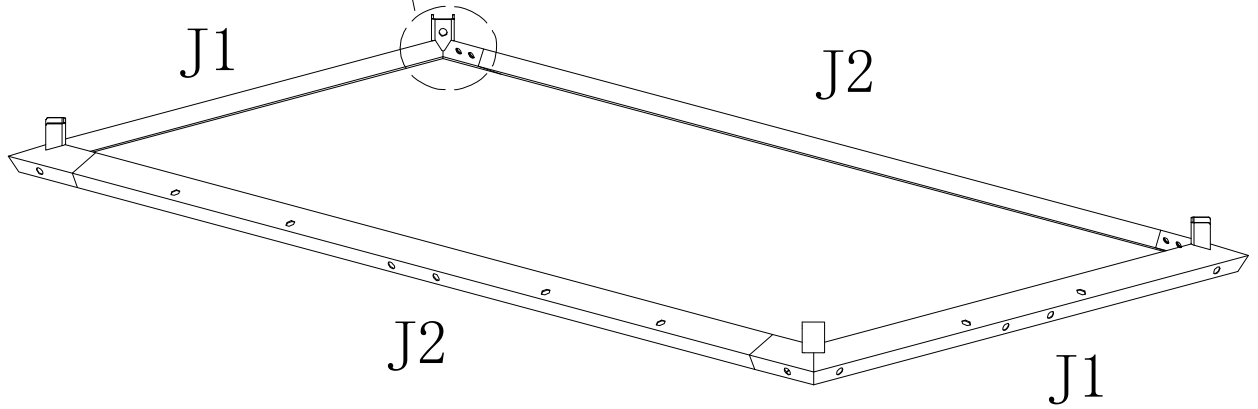

ⓐ J1 2X

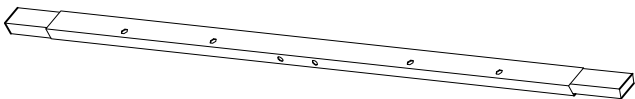

ⓑ J2 2X



ⓓ TT 8X

# <9>

**EN:** Connect top of big roof middle beam H2 with the short /long side tubes of big roof J1/J2, then connect bottom of big roof middle beam H2 with assembled beam C1/C2/D1/D2 by using screws TT.

**FR:** Connectez le haut de la poutre centrale H2 du grand toit avec les tubes latéraux courts / longs du grand toit J1/ J2, puis connectez le bas de la grande poutre centrale H2 du toit avec la poutre assemblée C1/C2/D1/D2 avec les vis TT.

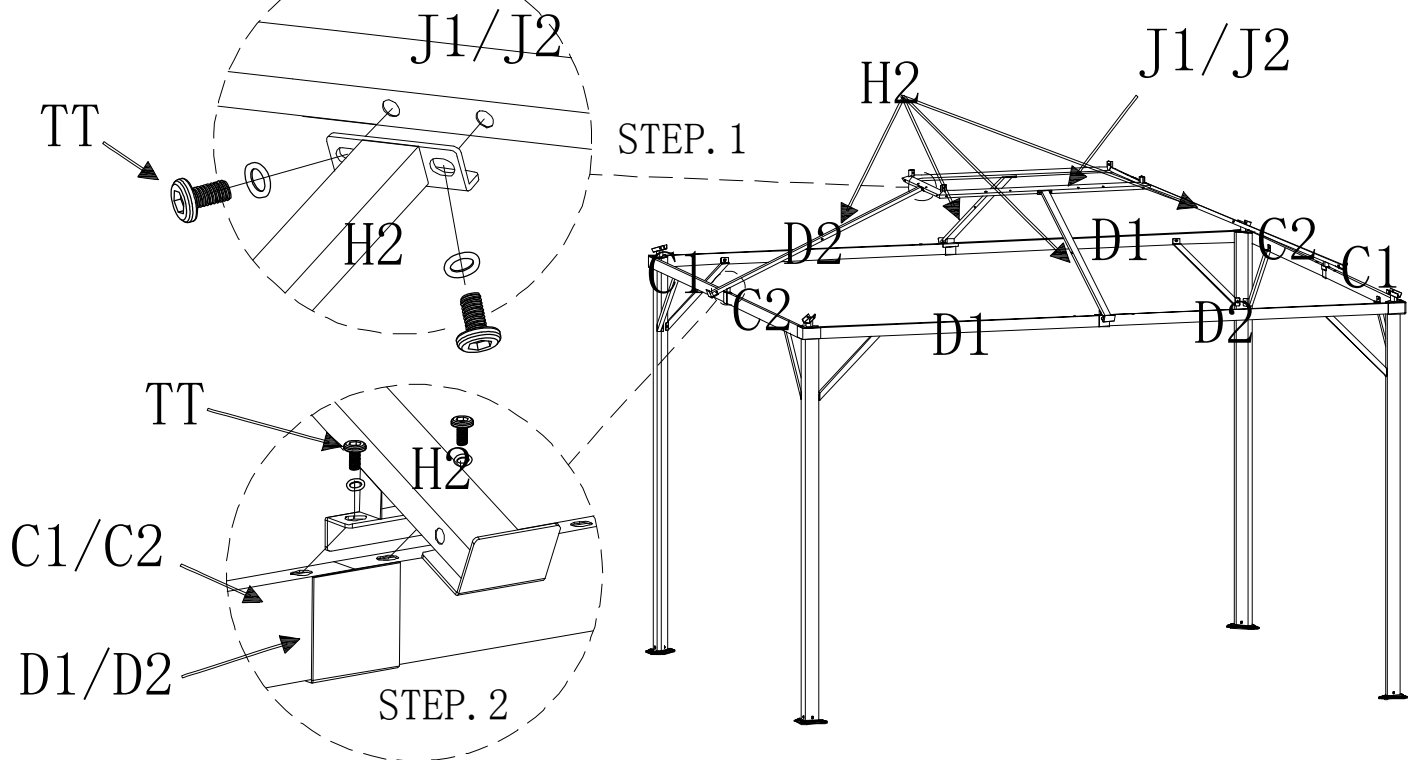

**EN:** Note: Please do not fully tighten screws TT into the assembled beam C1/C2/D1/D2 prior to complete assembly of frame in Step 19.

**FR:** Remarque: Veuillez ne pas serrer complètement les vis TT dans la poutre assemblée C1/C2/ D1/D2 avant l'assemblage complet du cadre à l'étape 19.

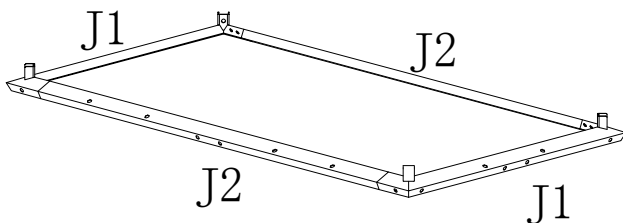

1X

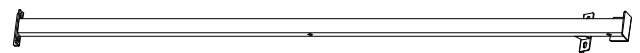

Ⓜ H2 4X

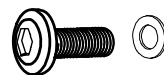

Ⓞ M6\*15

Ⓜ TT 16X

# <10>

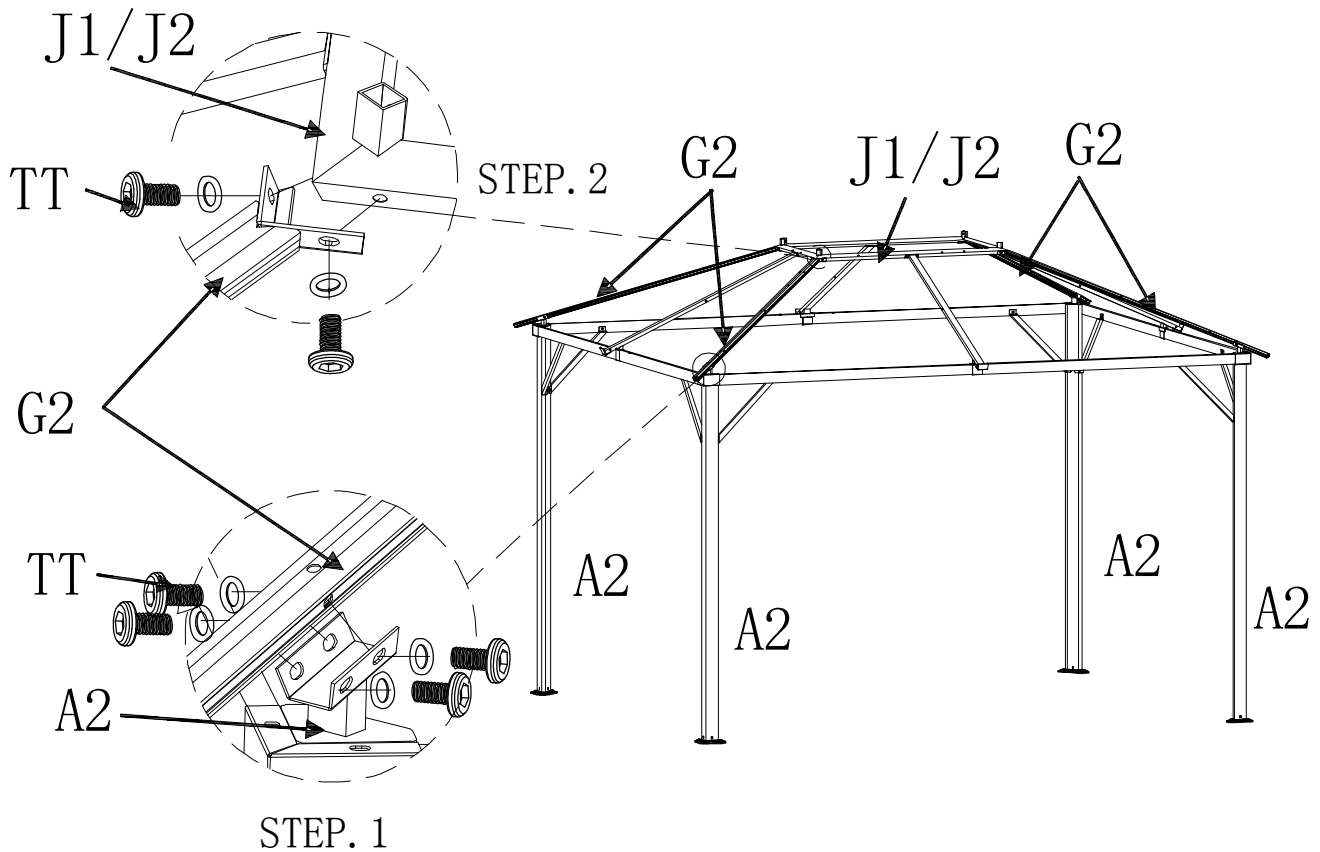

**EN:** Connect bottom of long slant beam G2 with Post A2 using screws TT, then connect top of bevel beam G2 with the short /long side tubes of big roof J1/J2 by using screws TT.

**FR:** Connectez le bas de la poutre oblique longue G2 avec le poteau A2 à l'aide de vis TT, puis connectez le haut de la poutre conique G2 avec les tubes latéraux courts / longs du grand toit J1/J2 avec les vis TT.



ⓐ G2 4X



ⓐ M6\*15

ⓐ TT 24X

# <11>

**EN:** Insert bottom of small roof slant beam (L1) into big roof assembled frame J1/J2, then insert small roof slant beam L1 upper end into small roof connector M1.

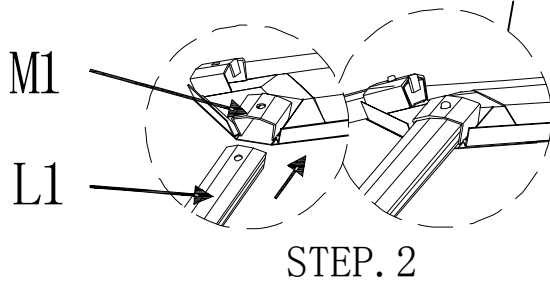
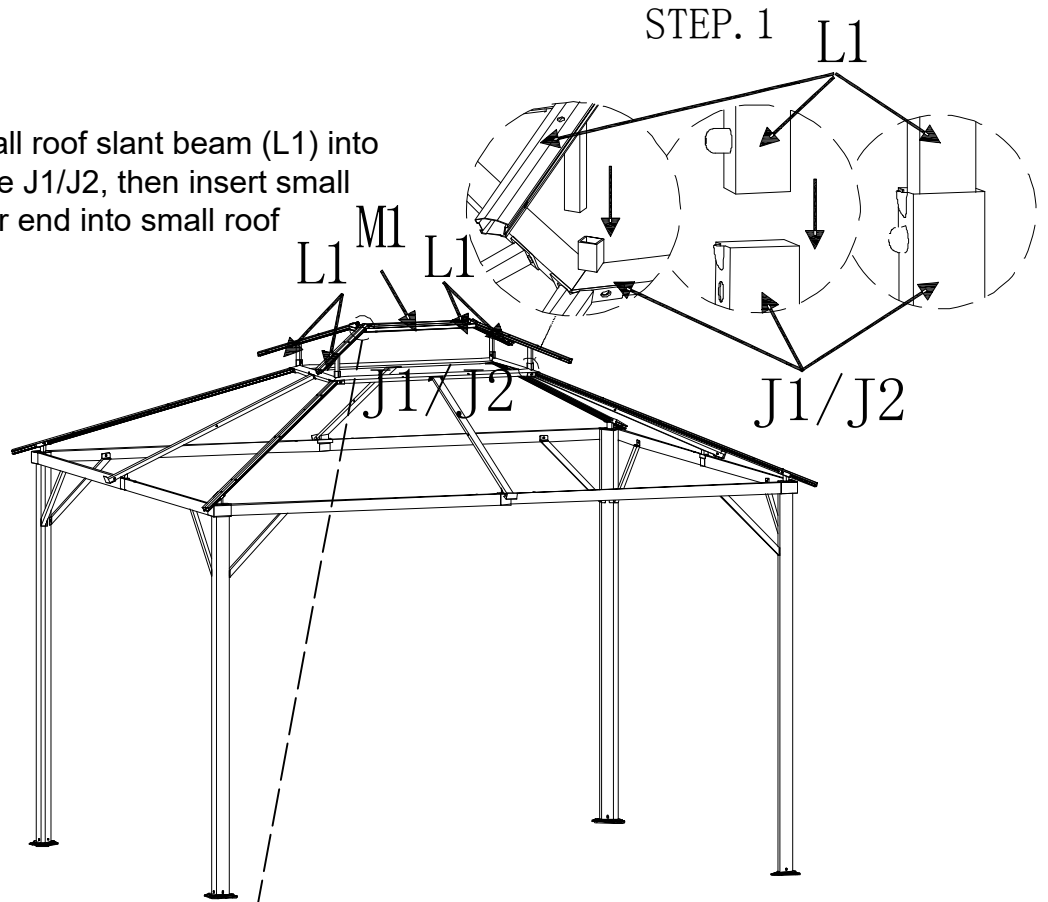

**FR:** Insérez le bas de la poutre oblique L1 du petit toit dans le grand toit assemblé cadre J1/J2, puis insérez la petite poutre oblique de toit L1 extrémité supérieure dans le petit connecteur de toit M1.

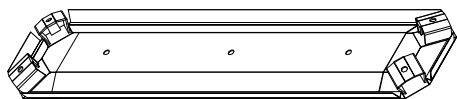

Ⓜ1 1X

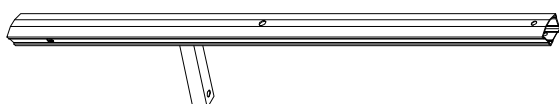

Ⓛ1 4X

# <12>

**EN:** Attach small roof short/long tubes Q1/Q2 to small roof slant beam L1 by using bolt II.

**FR:** Fixer des tubes courts/longs de petit toit Q1/Q2 à une poutre oblique L1 de petit toit avec les boulon II.

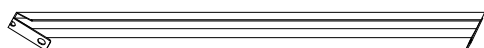
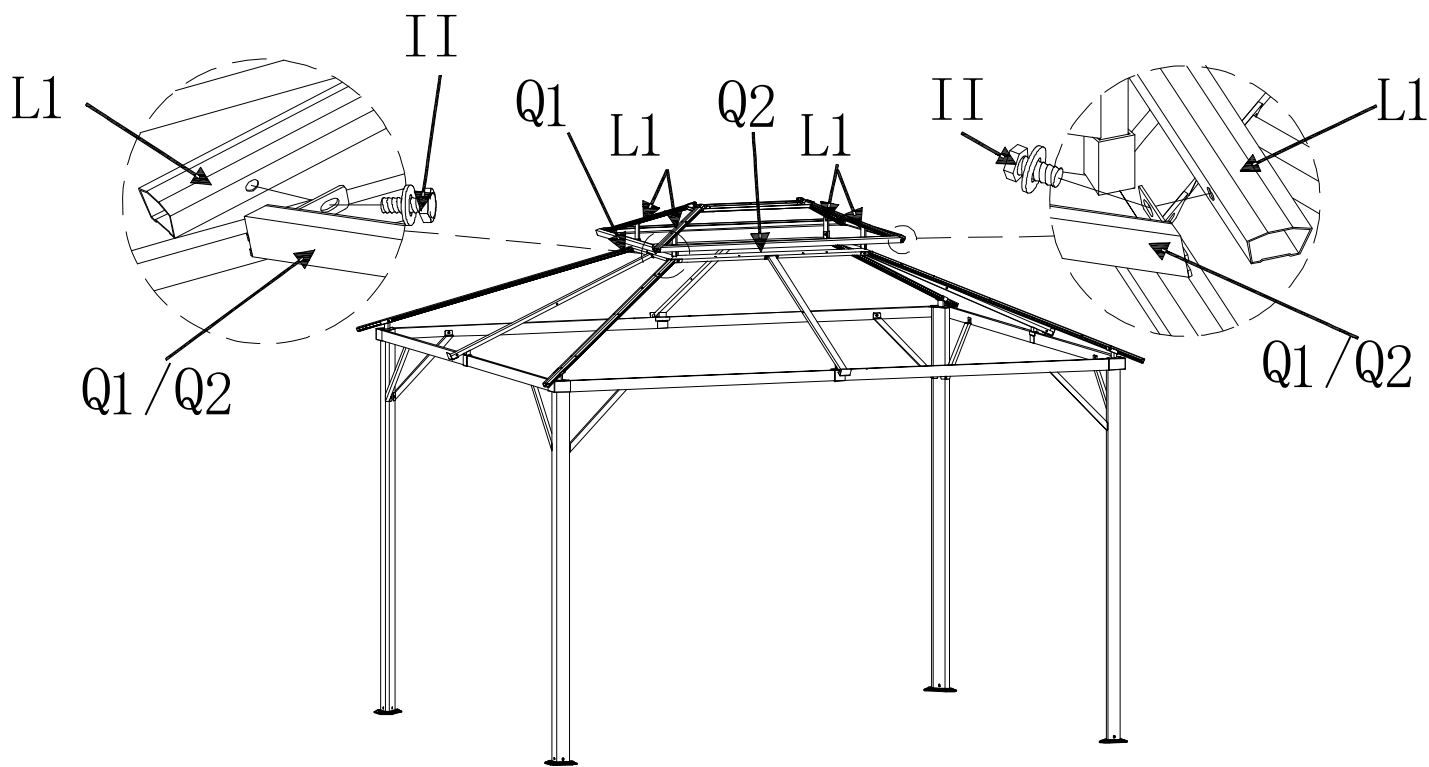

Ⓚ1 2X

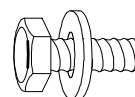

M6\*15

ⓀII 8X



Ⓚ2 2X

# <13>

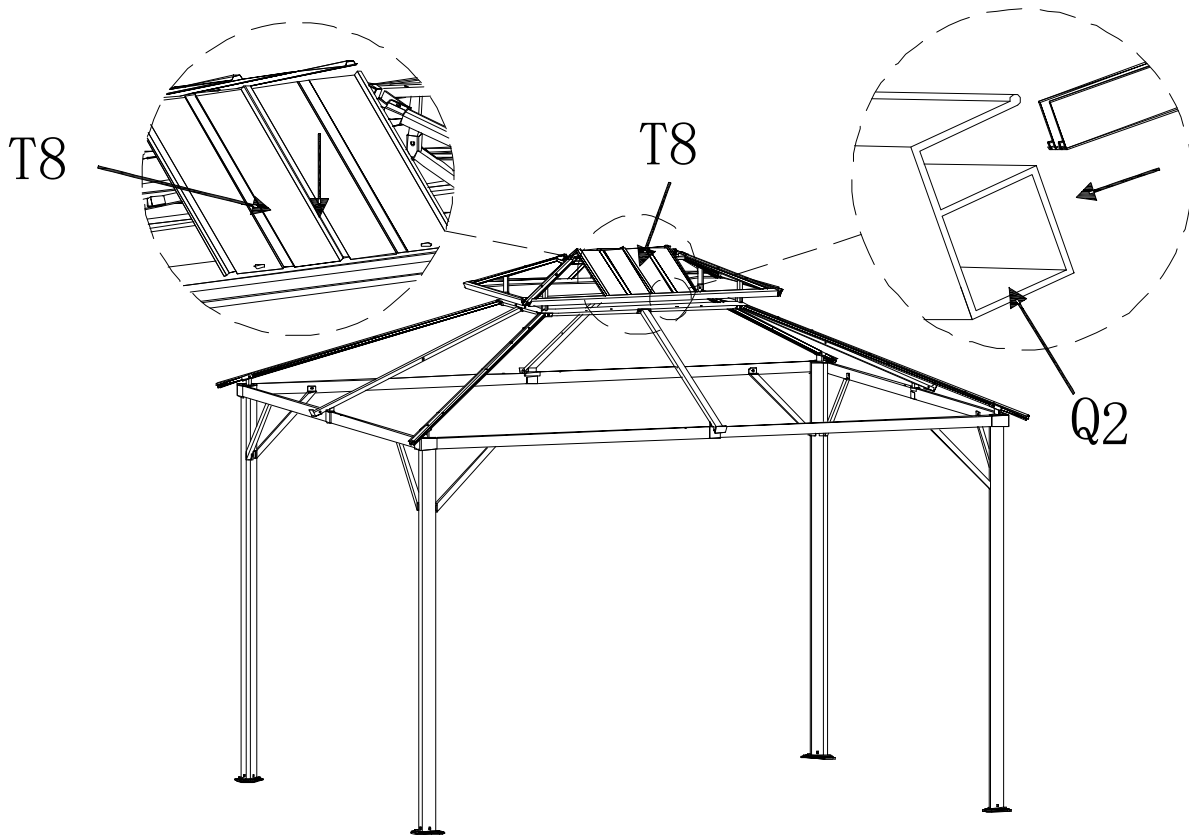

**EN:** Attach small roof middle cover plate T8 to small roof assembled frame.  
Note: insert lower end of cover plate into groove of small roof long tubes Q2)

**FR:** Fixer la plaque de couverture centrale T8 de petit toit à la charpente assemblée de petit toit.  
(Avis: insérer l'extrémité inférieure de la plaque de couverture dans la rainure de petits tubes longs de toit Q2)

**EN:** note: Place the small roof cover plate from the middle position to both side.

**FR:** Avis: Placez la plaque de couverture du petit toit de la position centrale des deux côtés.

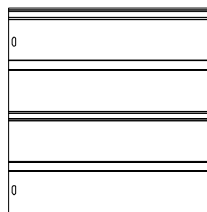

Ⓣ8 2X

# <14>

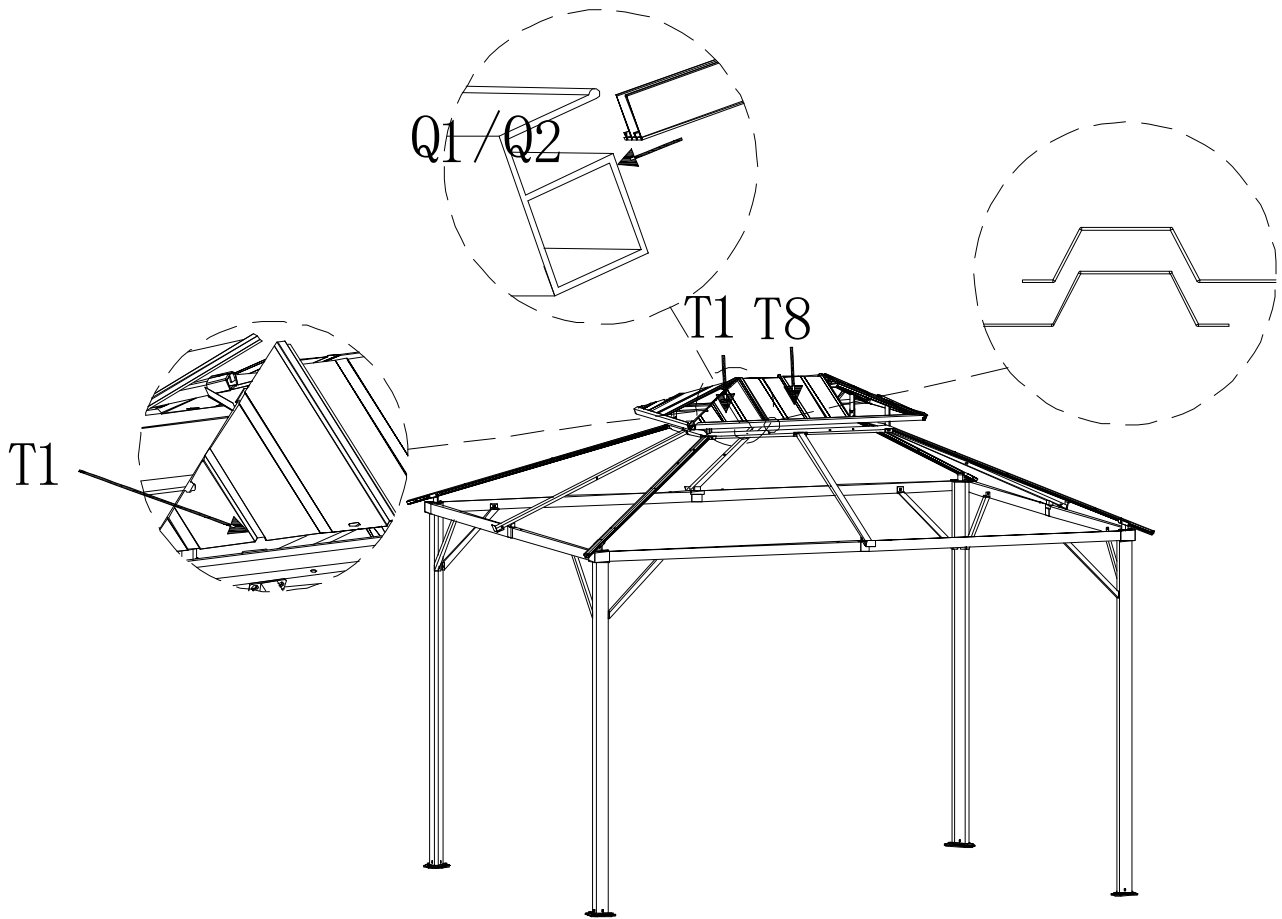

**EN:** Attach small roof left cover plate T1 to small roof assembled frame.  
(Note: Insert lower end of cover plate into groove of small roof short/long tubes(Q1/Q2),  
connection of cover plates are interlock)

**FR:** Fixer la plaque de couverture gauche T1 de petit toit à la charpente assemblée de petit toit.  
(Avis: Insérer l'extrémité inférieure de la plaque de recouvrement dans la rainure des tubes courts/  
longs (Q1/Q2) de petit toit, connexion de l'emboîtement de la plaque de recouvrement)

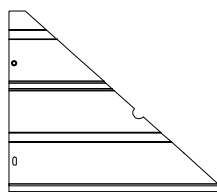

Ⓣ1 4X

# <15>

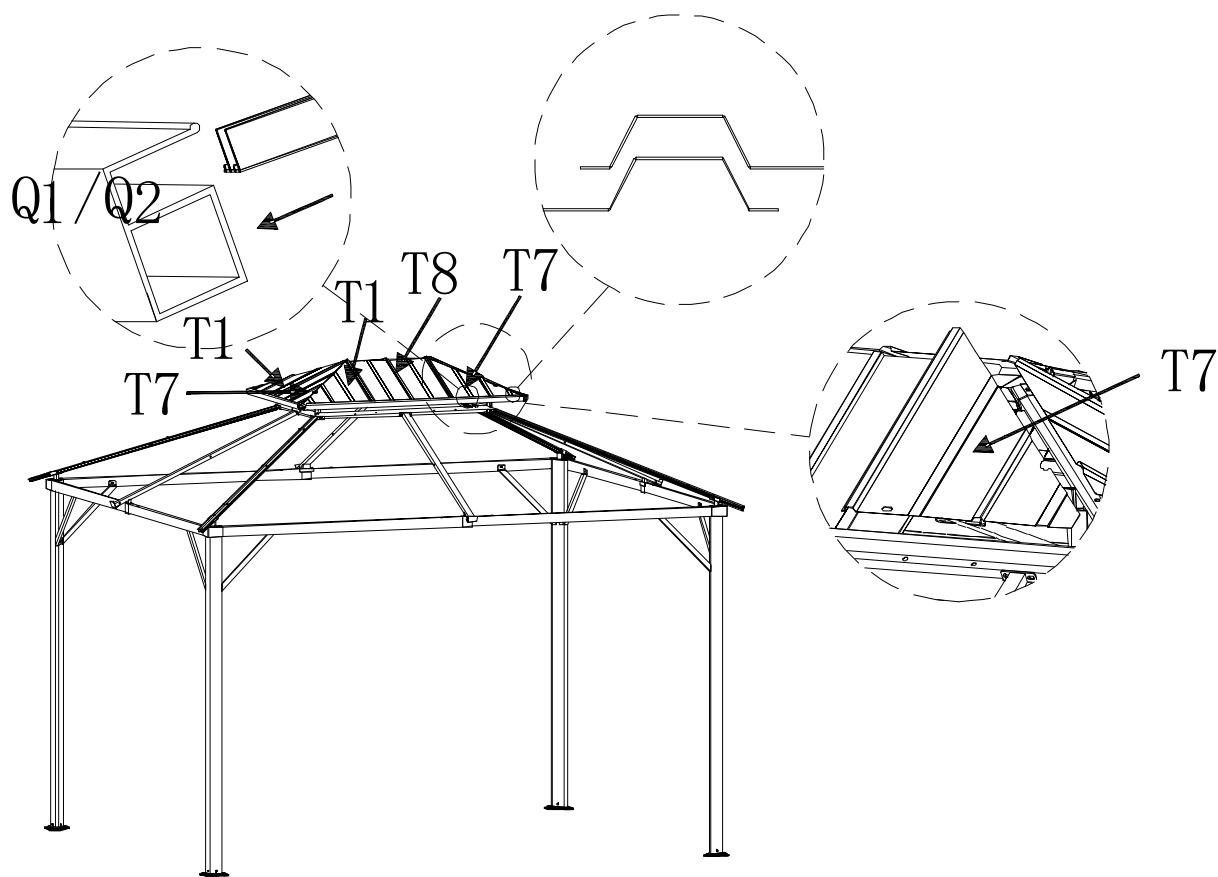

**EN:** Attach small roof right cover plate T7 to small roof assembled frame.  
(Note: Insert lower end of cover plate into groove of small roof short/long tubes(Q1/Q2), connection of cover plates are interlock)

**FR:** Fixez la plaque de couverture droite du petit toit T7 à la charpente assemblée du petit toit.  
(Avis: Insérez l'extrémité inférieure de la plaque de recouvrement dans la rainure de petits tubes courts / longs de toit Q1/Q2, connexion de l'emboîtement de la plaque de recouvrement)

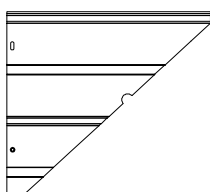

Ⓣ7 4X

# <16>

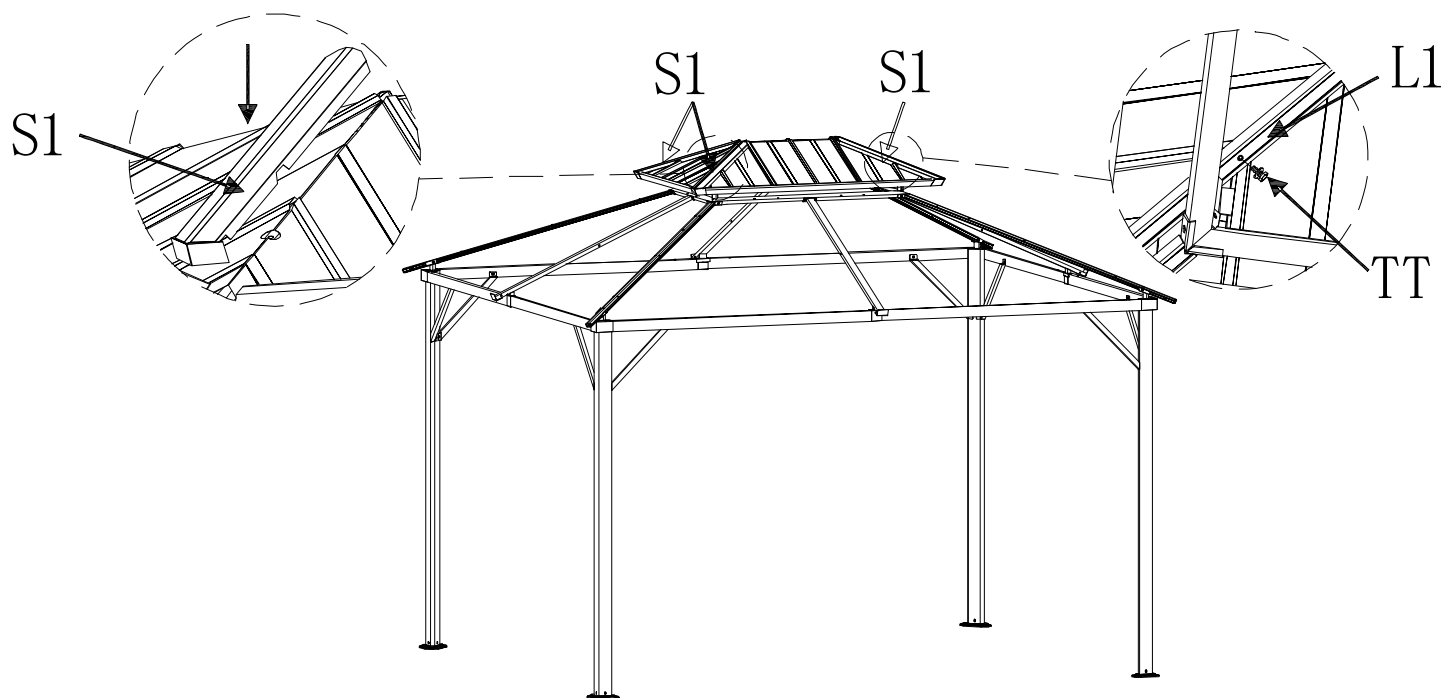

**EN:** Attach small roof side cover plate S1 to small roof slant beam L1, fix inner side small roof slant beam L1 by using screws TT.

**FR:** Fixer la plaque de couverture latérale S1 de petit toit à la poutre oblique L1 de petit toit, fixer la poutre inclinée latérale intérieure L1 de petit toit avec les vis TT.



(S1) 4X



M6\*15

(TT) 4X

# <17>

**EN:** Attach small roof cover P1 to small roof connector M1, fix inner side small roof connector M1 by using screws TT, then attach Hook N1 to small roof connector M1, turn hook to the right to tighten.

**FR:** Fixez le petit couvercle de toit P1 au petit connecteur de toit M1, fixez le petit connecteur de toit M1 côté intérieur avec les vis TT, puis fixez le crochet N1 au petit connecteur de toit M1, tournez le crochet vers la droite pour serrer.

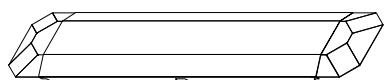
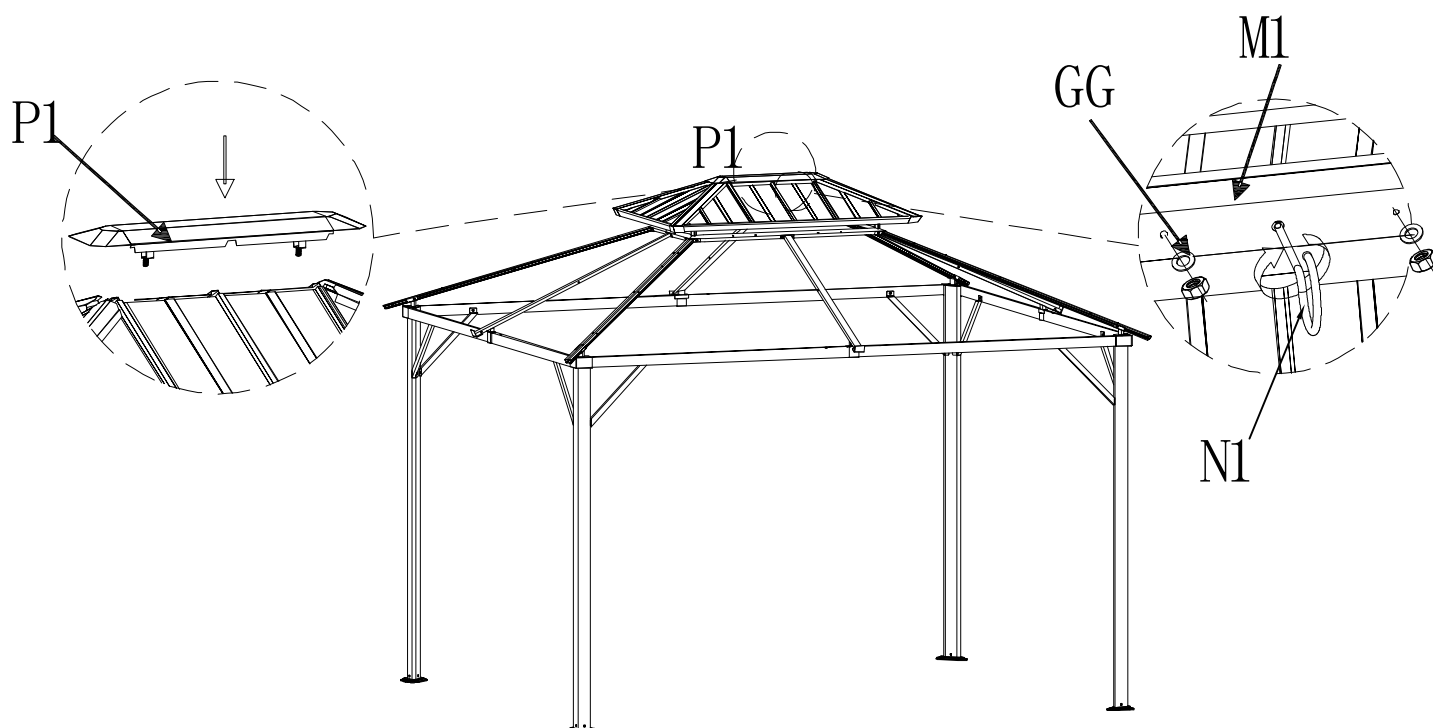

Ⓟ P1 1X

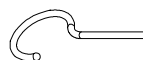

Ⓟ N1 1X

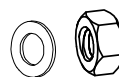

Ⓟ GG 2X

# <18>

**EN:** Attach lower long /short tubes F3/F4/K5/K6 to big roof slant Beam G2 and big roof middle beam H2 by using screws TT/bolts II.

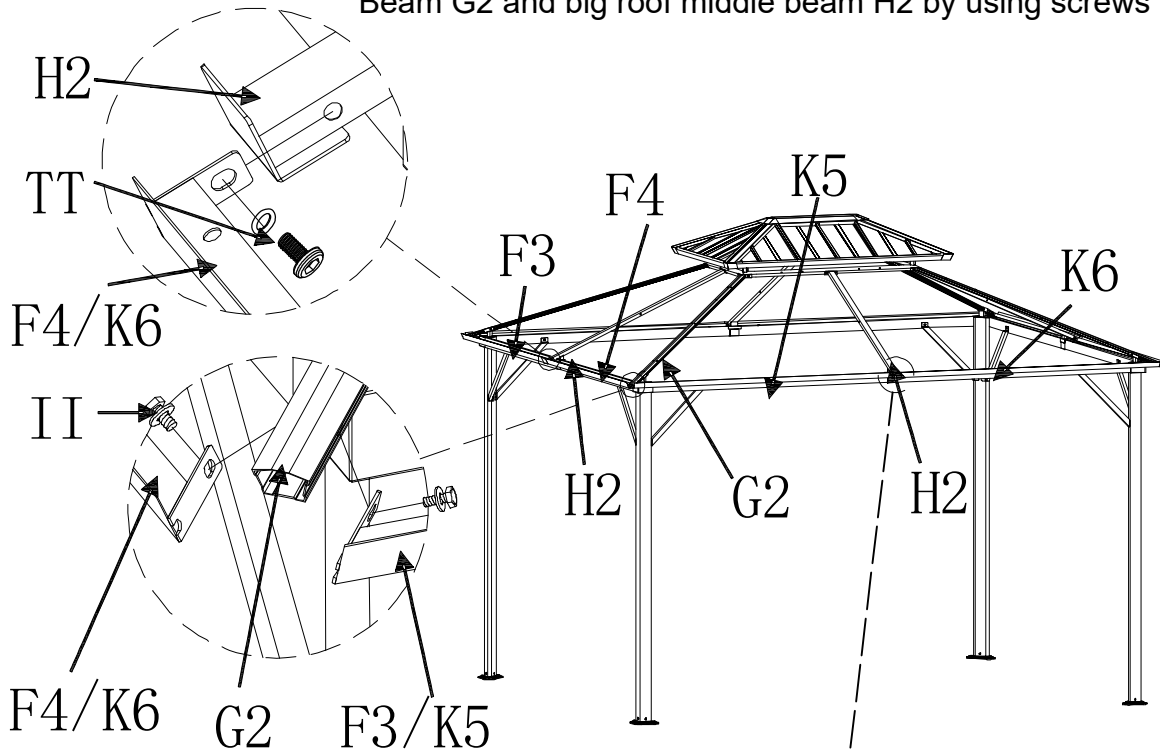

**FR:** Fixez les tubes longs/courts inférieurs F3/F4/K5/K6 à la poutre oblique G2 du grand toit et à la poutre centrale H2 du grand toit avec les vis TT/boulons II.

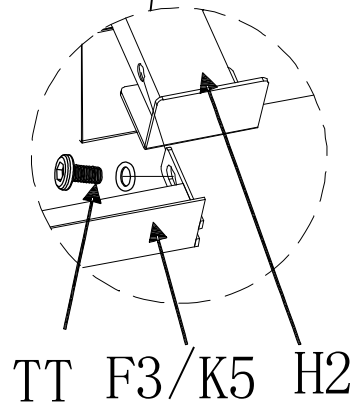

ⓕ F3 2X



ⓕ F4 2X



ⓕ K5 2X



ⓕ K6 2X



M6\*15



ⓕ 8X



M6\*15



ⓕ 8X

# <19>

**EN:** Attach big roof upper short/long tubes K1/K2 to big roof middle beam H2 by using screws TT, attach another end of big roof upper long/short beam K1/K2 to big roof slant beam G2 by using screws (TT).

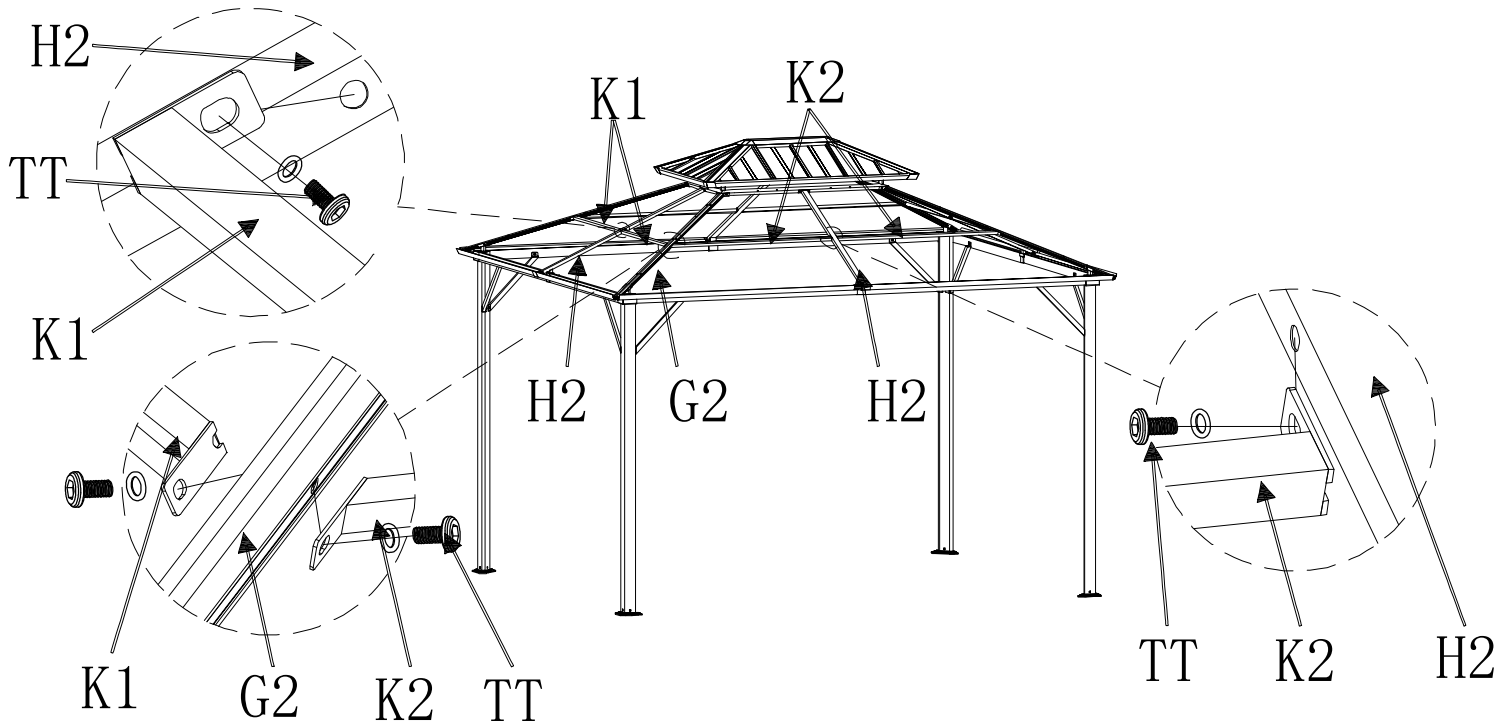

**FR:** Fixez les tubes courts/longs supérieurs K1/K2 du grand toit à la poutre centrale H2 du grand toit avec les vis TT, fixez une autre extrémité de la partie supérieure longue/courte tu K1/K2 du grand toit à la poutre oblique G2 du grand toit avec les vis TT.

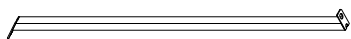

(K1) 4X



(K2) 4X



M6\*15

(TT) 16X

# <20>

**EN:** Attach big roof middle cover plate T4 to big roof assembled frame.

**FR:** Fixez la plaque de couverture centrale T4 de grand toit à la charpente assemblée du grand toit.

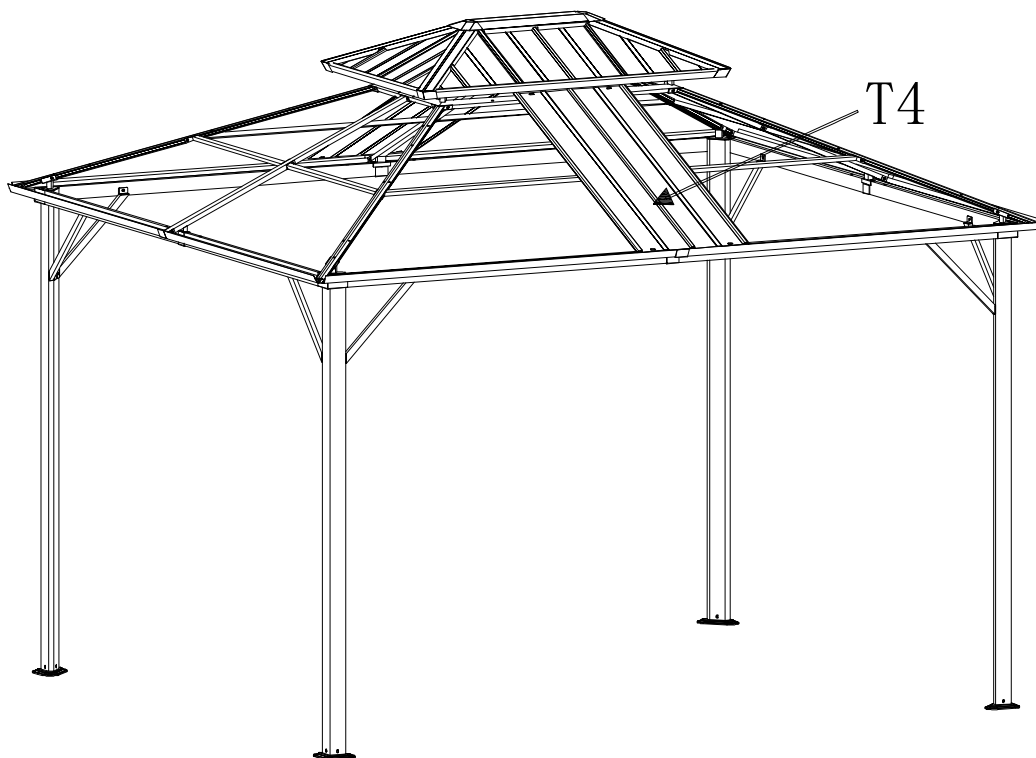

**EN:** note: Place the big roof cover plate from the middle position to both side.

**FR:** Avis: Placez la plaque de couverture du grand toit de la position centrale des deux côtés.

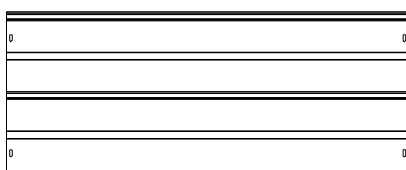

Ⓣ4 2X

# <21>

**EN:** Attach small press pane R1 to upper of big roof left middle cover plates T3 / middle cover plates T4/ right middle cover plates T5 to assembled frame by using screws TT.

**FR:** Fixez la petite presse R1 à la partie supérieure des plaques de couverture centrale gauche T3 / plaques de couverture centrale T4 / plaques de couverture centrale droite T5 à la charpente assemblée de grand toit avec les vis TT.

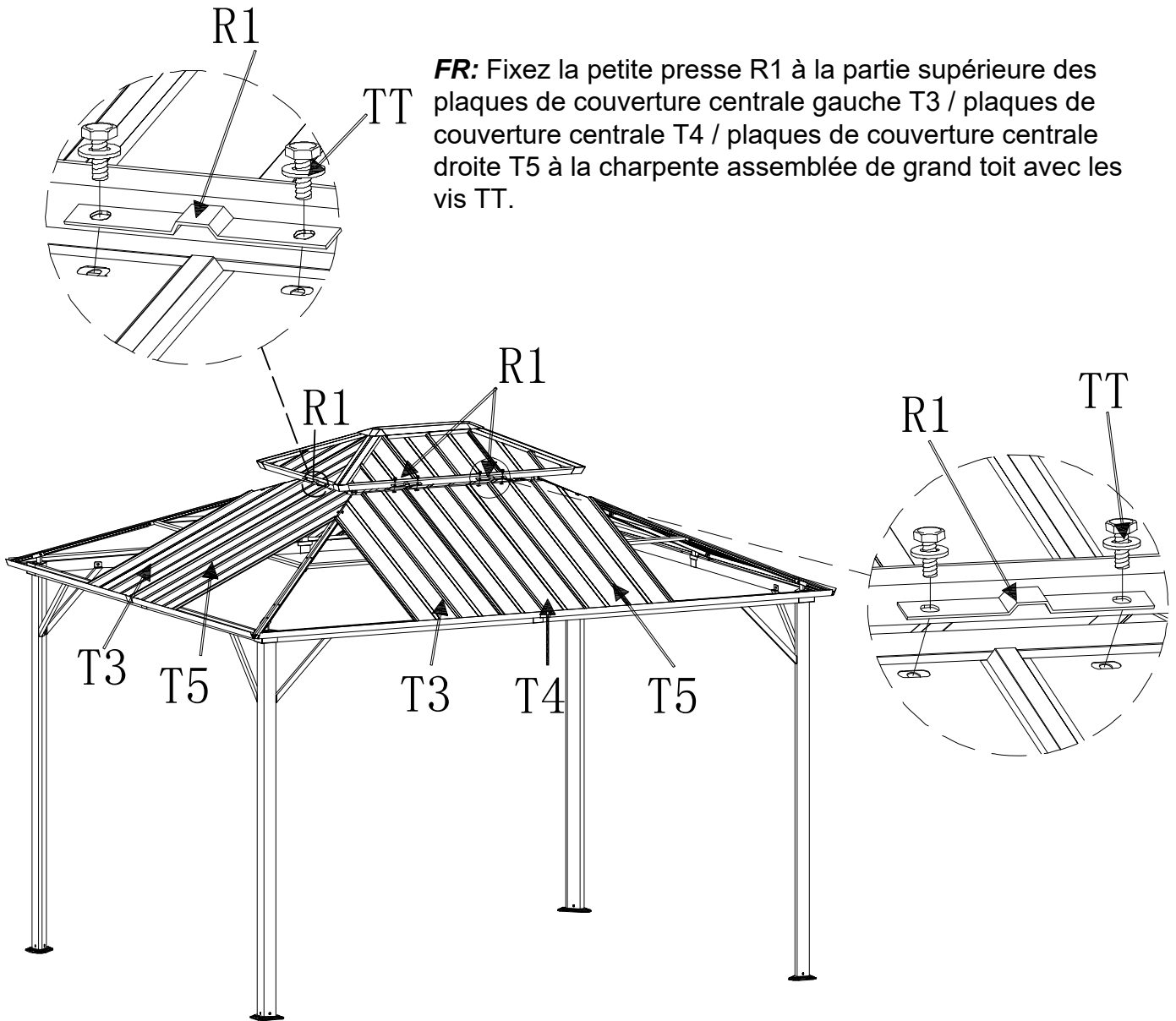

**EN:** Note: Please do not fully tighten screws TT prior to complete assembly for all small/big cover plates in Step 24.

**FR:** Avis: Veuillez ne pas serrer complètement les vis TT avant de terminer l'assemblage pour toutes les petites/grandes plaques de couverture à l'étape 24.

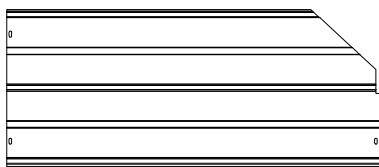

Ⓣ3 4X

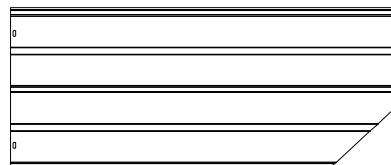

Ⓣ5 4X

Ⓜ6\*15

ⓉⓉ 12X



Ⓡ1 6X

<22>

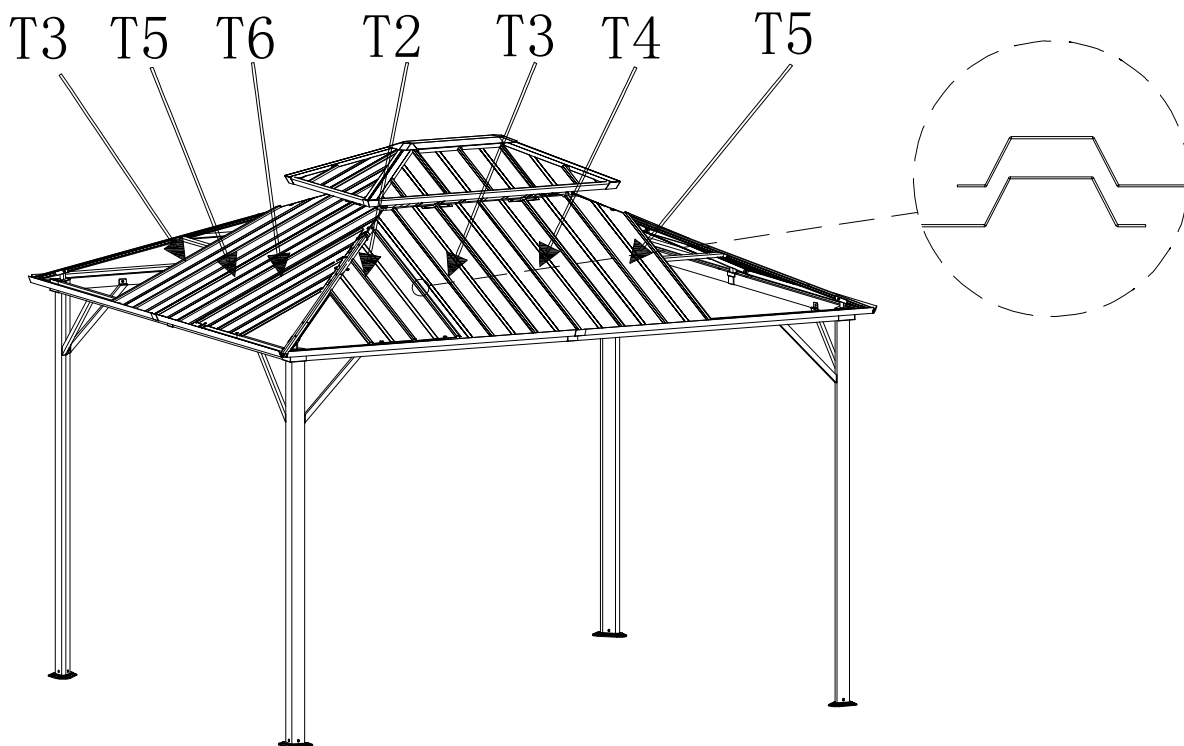

**EN:** Attach big roof right cover plate T6 and big roof left cover plate T2 to the big roof assembled frame (Note: connection of cover plates are interlock.)

**FR:** Fixer la plaque de couverture droite T6 de grand toit et la plaque de couverture gauche T2 de grand toit à la charpente assemblée de grand toit (Avis: connexion de l'emboîtement de la plaque de recouvrement)

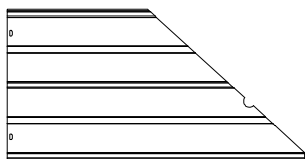

(T2) 4X

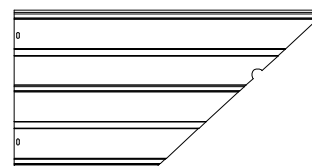

(T6) 4X

<23>

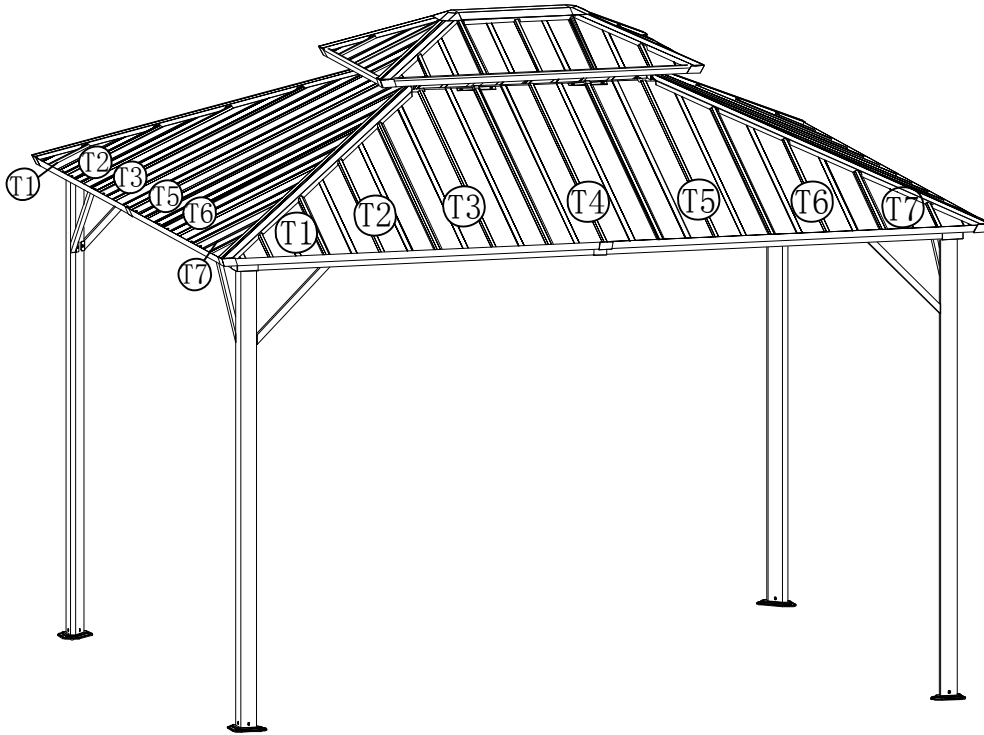

**EN:** All of the left/right small cover plates T1/T7 must be evenly put.

**FR:** Toutes les petites plaques de couverture gauche/droite T1/T7 doivent être placées uniformément.

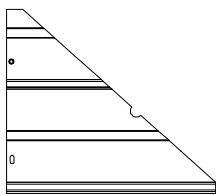

(T1) 4X

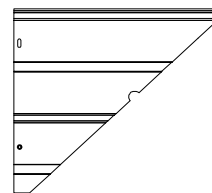

(T7) 4X

# <24>

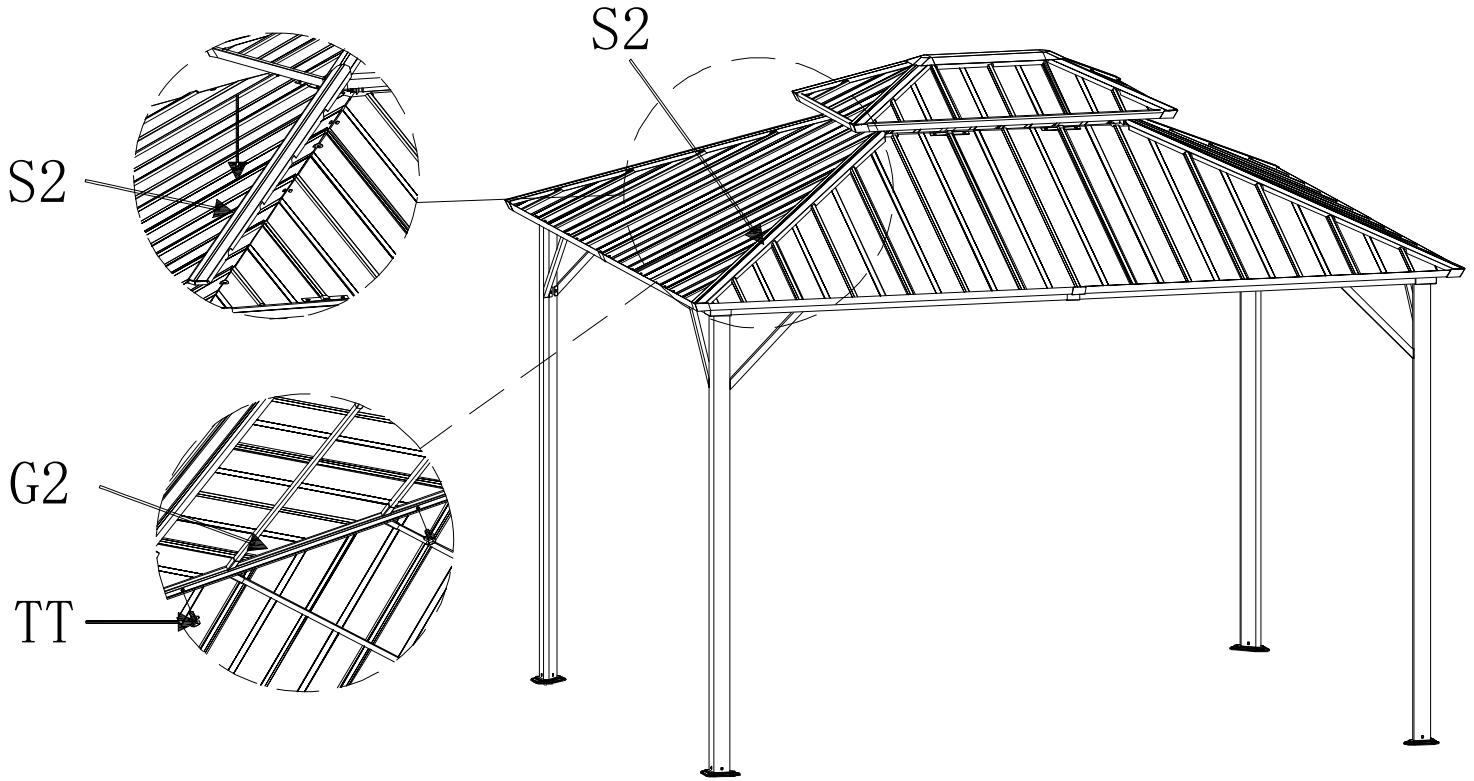

**EN:** Attach big roof long slant beam cover S2 to big roof long slant beam G2, fix inner side of long slant beam G2 by using bolts TT.

**FR:** Fixez le long couvercle de poutre oblique S2 de grand toit à la poutre oblique longue G2 de grand toit, fixez le côté intérieur de la poutre oblique longue G2 avec les vis TT.

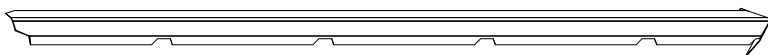

(S2) 4X



M6\*15

(TT) 8X

# <25>

9B. Ü^~ã^ã&iaj

: F. Ú^!&^•^Á•đ..&••ã^

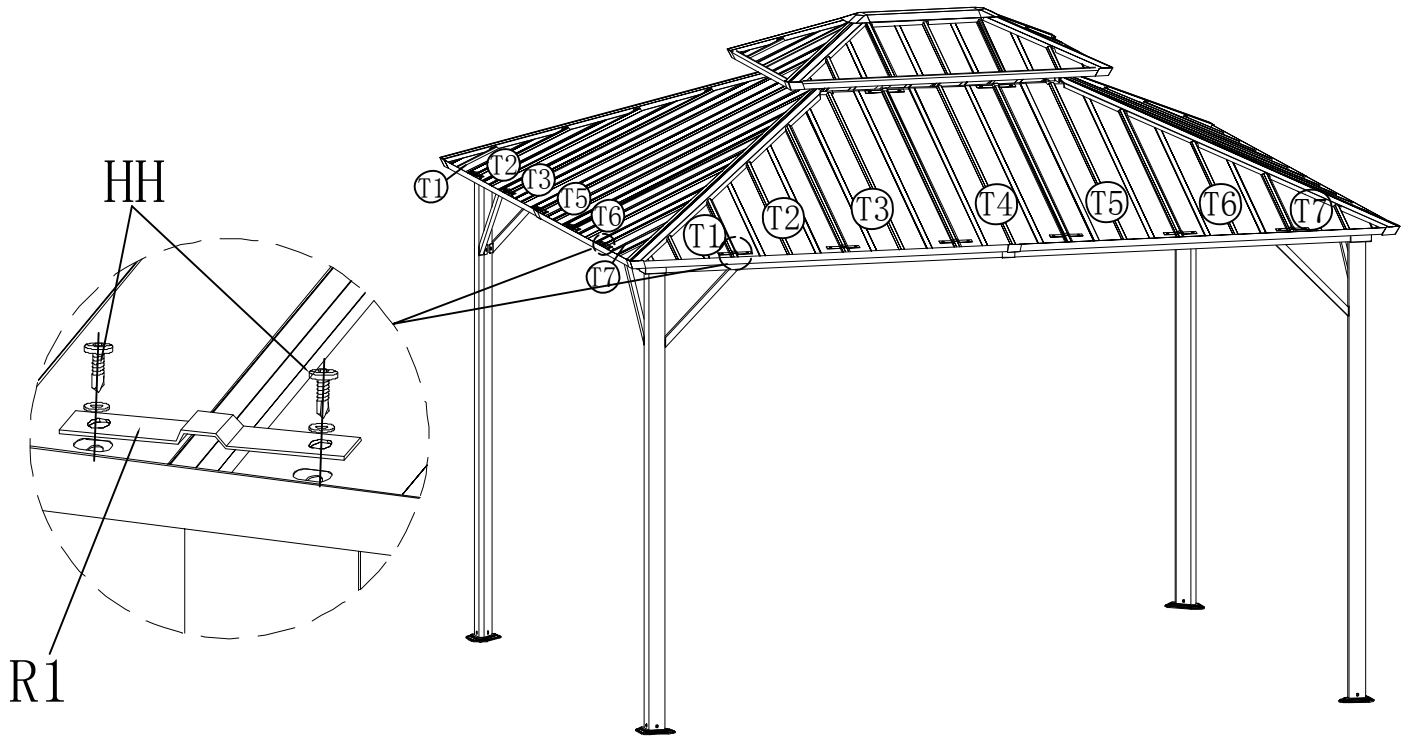

**EN:** Attach press panel R1 to the bottom of cover plate to big roof assembled frame by using Bolts (HH).

**FR:** Fixez le panneau de presse R1 au bas de la plaque de couverture à la charpente assemblée du grand toit avec les boulons HH.

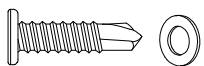

M6\*15

(HH) 44X



(R1) 22X

<26>

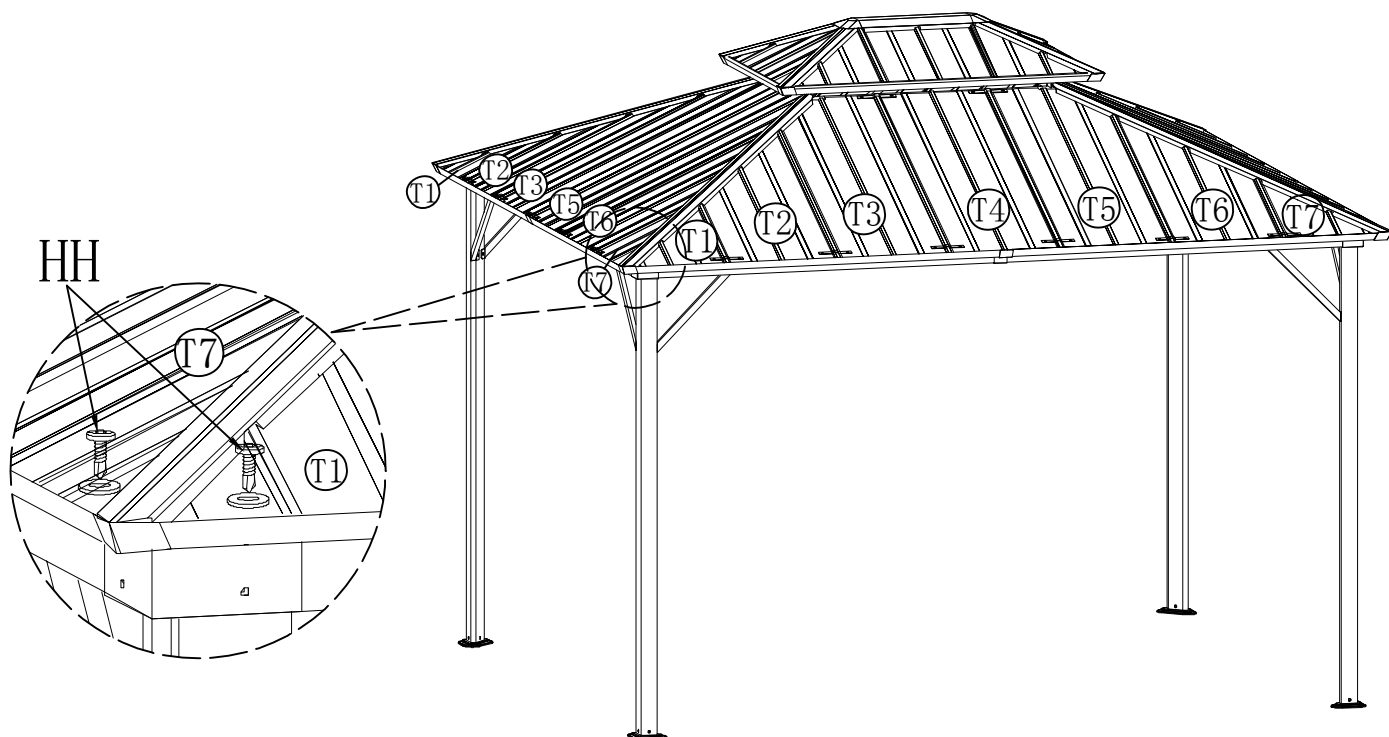

**EN:** Fix the corners of the big roof cover plates by using bolts HH.

**FR:** Fixez les coins des plaques de couverture du grand toit avec les boulons HH.

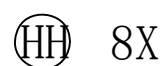

<27>

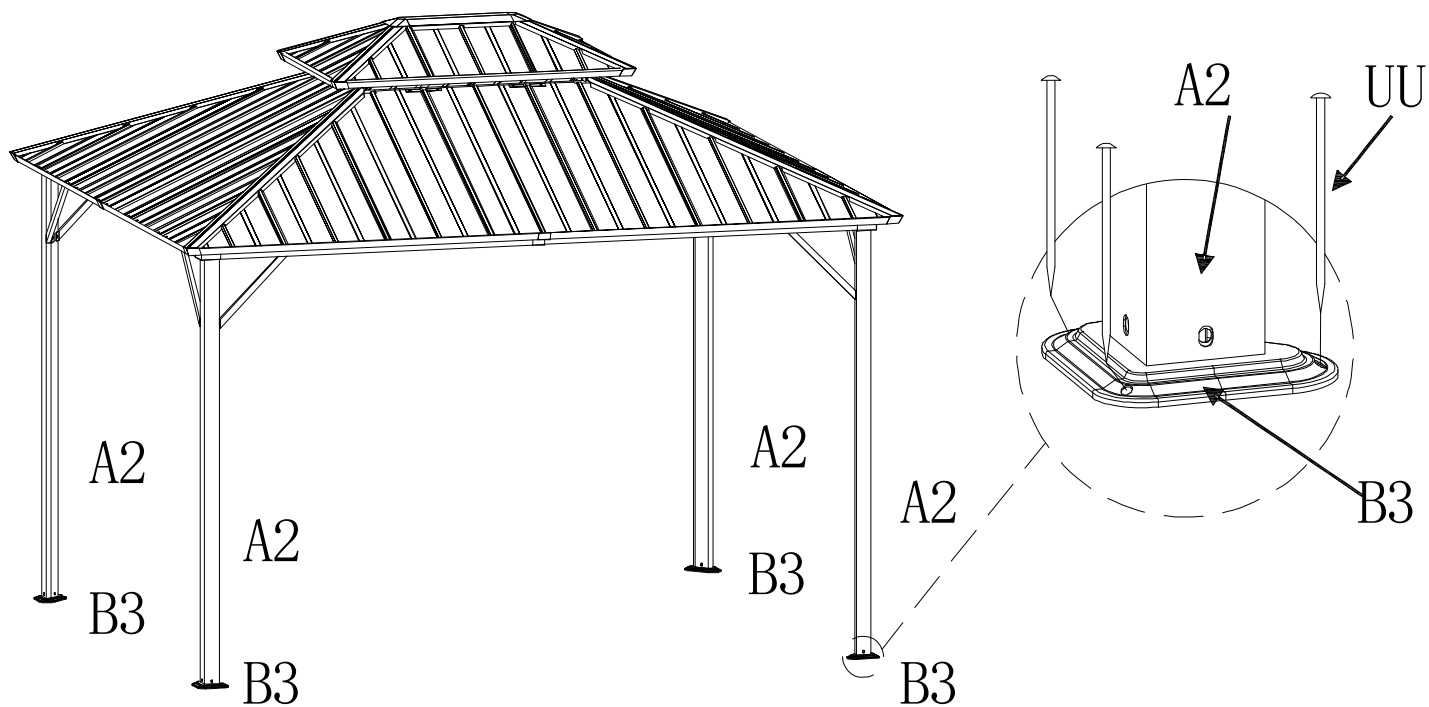

**EN:** Fix base B3 of post A2 on the ground by using stake UU.

**FR:** Fixer la base B3 du poteau A2 au sol à l'aide du piquet UU.

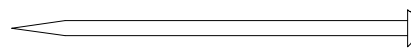

UU 12X

## EN

### Care and Maintenance

1. Our steel components for garden accessories and furniture are treated with rust inhibiting paint that protects it from rusting. However, due to the nature of steel, surface oxidation (rusting) will occur once these protective coatings are scratched. This is not a defect and thus not covered by the warranty.
2. To minimize this condition, we recommend care when assembling & handling the product to prevent scratching the paint. Should any scratching or damage occur, we recommend immediate touch-up with rust inhibiting paint.
3. Surface rust can also be easily removed with a very light application of common cooking oil. If surface oxidation (rusting) occurs and if no measure is taken to prevent this, the oxidation may start dripping on to deck or patio and caused damaging stains, which may be difficult to remove. This can be prevented if the above-mentioned measures are taken to keep the product from oxidizing.
4. Use damp cloth to wipe off the stains as quickly as possible.
5. If necessary, wash with a mild solution of soap and water; rinse thoroughly and dry completely.
6. Periodically check and ensure that all bolts are well-tighten during use.

## FR:

### Maintenance préventive et corrective

1. Les composants en acier des meubles et accessoires de jardin sont traités avec une peinture antirouille pour les protéger de la rouille. Cependant, en raison de la nature de l'acier, une oxydation de surface (rouille) se produira une fois ces revêtements protecteurs rayés. Ce qui n'est pas un défaut et n'est donc pas couvert par la garantie.
2. Afin de minimiser l'occurrence de cette situation, nous vous recommandons de veiller lors de l'assemblage et de la manipulation du produit à éviter de rayures sur la peinture. En cas de rayures ou de dommages, il est recommandé de les réparer immédiatement par une peinture antirouille.
3. La rouille de surface sera également facilement éliminée avec une très légère application d'huile de cuisson courante. Si une oxydation de surface (rouille) se produit et qu'aucune mesure n'est prise, l'oxydation peut commencer à s'égoutter sur la terrasse ou le patio, provoquant des taches dommageables qui seront difficiles à enlever. Les mesures mentionnées ci-dessus sont pour éviter l'oxydation du produit.
4. Nettoyez les taches dès que possible avec un chiffon humide.
5. Si nécessaire, lavez-le avec une solution d'eau et de savon doux, puis le rincez et séchez complètement.
6. Vérifiez périodiquement et assurez-vous que tous les boulons sont serrés pendant l'utilisation.