

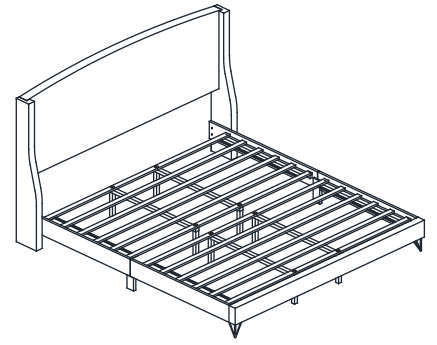



ASSEMBLY INSTRUCTION

KING / KING

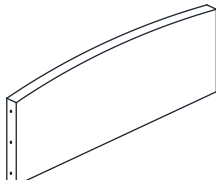
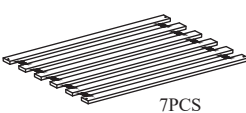
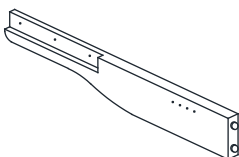
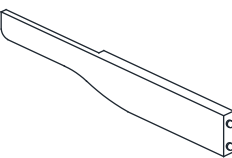
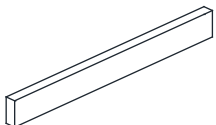
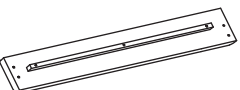
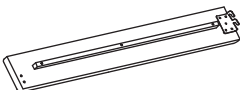
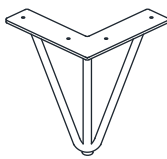

1. Read this instructions carefully.
2. See hardware and furniture part list for guidance.
3. Be sure all parts are complete before you assemble.
4. Place all wooden furniture parts on a clean and flat soft surface to prevent from being scratched.
5. Follow the figure to start assembling.

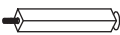

PART LIST

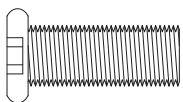
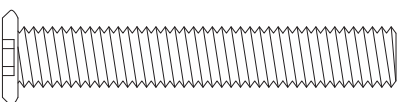
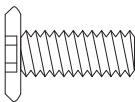
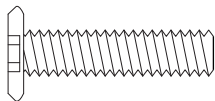
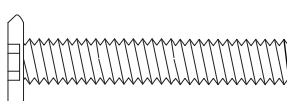

<p>1. HEADBOARD PANEL</p>  <p style="text-align: center;">x 1PC</p>	<p>2. ROLL SLAT</p>  <p style="text-align: center;">7PCS</p> <p style="text-align: center;">x 2 SET</p>	<p>3. LEFT WING (with "L" label)</p>  <p style="text-align: center;">x 1PC</p>	<p>4. RIGHT WING (with "R" label)</p>  <p style="text-align: center;">x 1PC</p>	<p>5. FOOTBOARD PANEL</p>  <p style="text-align: center;">x 1PC</p>
<p>6. (LEFT & RIGHT) HEADBOARD SIDE RAIL</p>  <p style="text-align: center;">x 2PCS</p>	<p>7. (LEFT & RIGHT) FOOTBOARD SIDE RAIL</p>  <p style="text-align: center;">x 2PCS</p>	<p>8. LEG</p>  <p style="text-align: center;">x 2PCS</p>	<p>9. CENTER RAIL</p>  <p style="text-align: center;">x 4PCS</p>	<p>10. CENTER RAIL SUPPORT LEG WITH LEVELER</p>  <p style="text-align: center;">x 8PCS</p>
<p>11. SIDE RAIL SUPPORT LEG</p>  <p style="text-align: center;">x 2PCS</p>				

HARDWARE LIST (IN ACTUAL SIZE/SCALE FOR REFERENCE)

<p>A. JCBB BOLT M8 x 20mm</p>  <p style="text-align: center;">x 4PCS</p>	<p>B. JCBB BOLT M8 x 50mm</p>  <p style="text-align: center;">x 4PCS</p>	<p>C. JCBB BOLT M6 x 15mm</p>  <p style="text-align: center;">x 6PCS</p>
<p>D. JCBC BOLT M6 x 25mm</p>  <p style="text-align: center;">x 8PCS</p>	<p>E. JCBC BOLT M6 x 35mm</p>  <p style="text-align: center;">x 6PCS</p>	<p>F. SPRING WASHER M6 x 12mm</p>  <p style="text-align: center;">x 14PCS</p>

ASSEMBLY INSTRUCTION

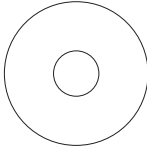
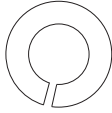
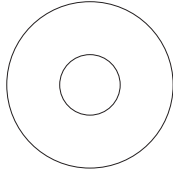
HARDWARE LIST (IN ACTUAL SIZE/SCALE FOR REFERENCE)

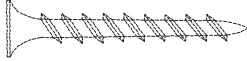
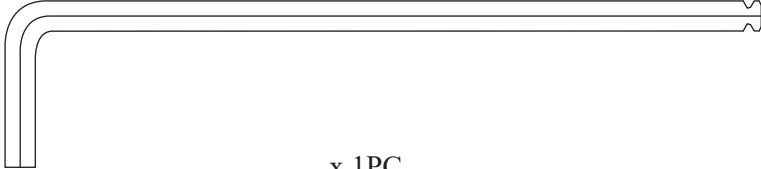
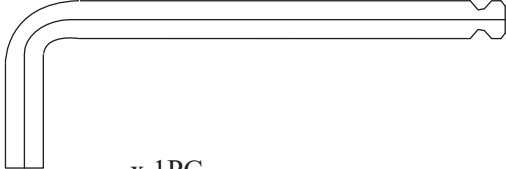
<p>G. FLAT WASHER M6 x 19mm</p>  <p>x 14PCS</p>	<p>H. SPRING WASHER M8 x 13mm</p>  <p>x 4PCS</p>	<p>I. FLAT WASHER M8 x 22mm</p>  <p>x 4PCS</p>
<p>J. WOOD DOWEL M10 x 30mm</p>  <p>x 4PCS</p>	<p>K. SCREW M4 x 32mm</p>  <p>x 8PCS</p>	
<p>L. L-KEY M4 x 100mm</p>  <p>x 1PC</p>		
<p>M. L-KEY M5 x 65mm</p>  <p>x 1PC</p>		

CAUTIONS:

1. DO NOT Fully-Tighten the nut or bolt until all nut or bolt is ready assembled.
2. DO NOT Over-Tighten the nut or bolt to avoid causing damages to the thread.
3. Keep all hardware parts out of reach of children.

NOTE: THE LIST AND QUANTITY SHOWN ARE FOR 1 UNIT ASSEMBLY.

!! ATTENTION !!

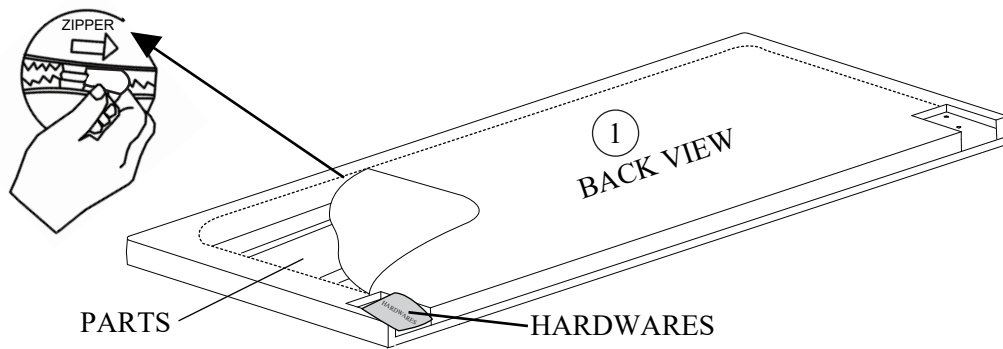

- Lay the Headboard Panel (1) with the back side facing up on a clean surface and make sure there are no sharp objects underneath.
- Hardwares Package is stapled on corner of the Backside of Headboard Panel (1)
- Parts are inside the Headboard. Unzip the cover on the Back of Headboard Panel (1) all the way and take out all the Parts out.
- Close the zip of the cover back properly before start assembly.

STEP 1

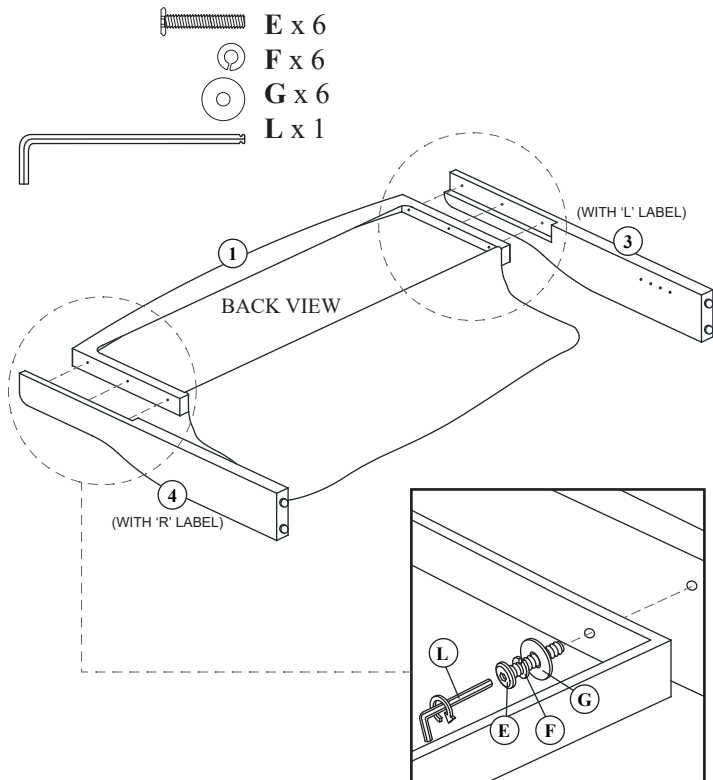

Attach Left & Right Wing (3 & 4) to Headboard Panel (1) by aligning the holes and secure using Bolt (E) and Spring Washer (F), Flat Washer (G) ; Then tighten all Bolts with L-Key (L).

STEP 2

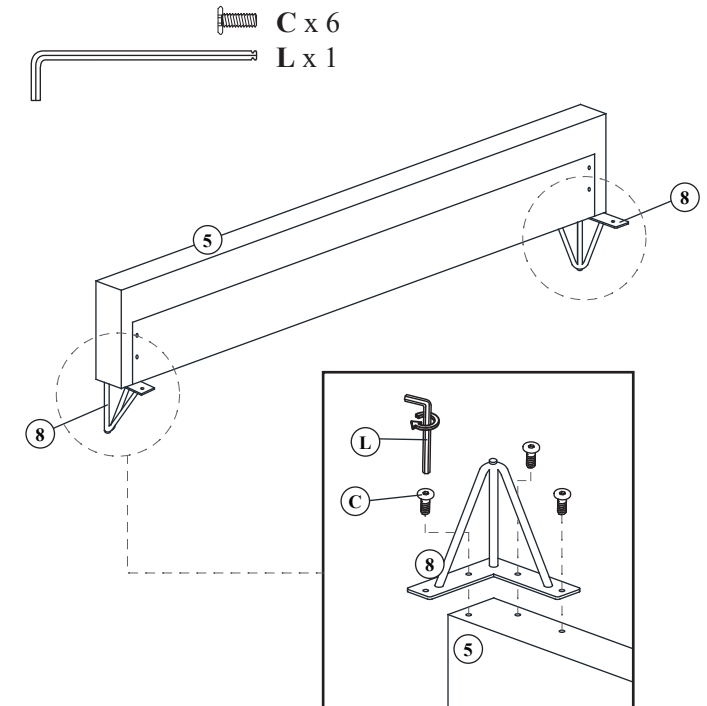

Attach Leg (8) to Footboard Panel (5) using Bolt (C) and tighten with L-Key (L).

STEP 3

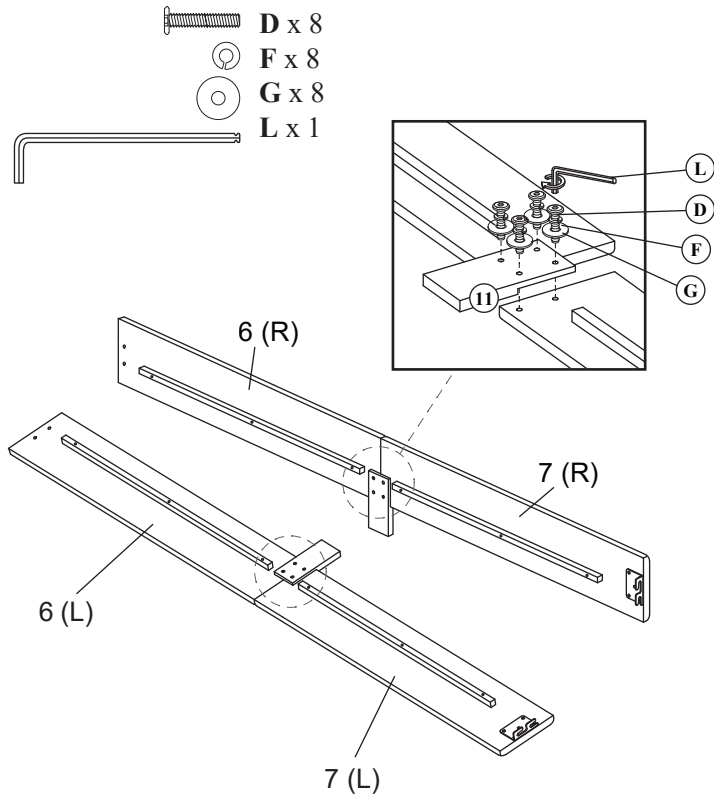

Connect RIGHT Side Rails (6 & 7) with Side Rail Support Leg (11), then secure using Bolt (D), Spring Washer (F), Flat Washer (G) and tighten all with L-Key (L), as shown in picture above. Repeat the same way to connect LEFT Side Rails (6 & 7).

STEP 4

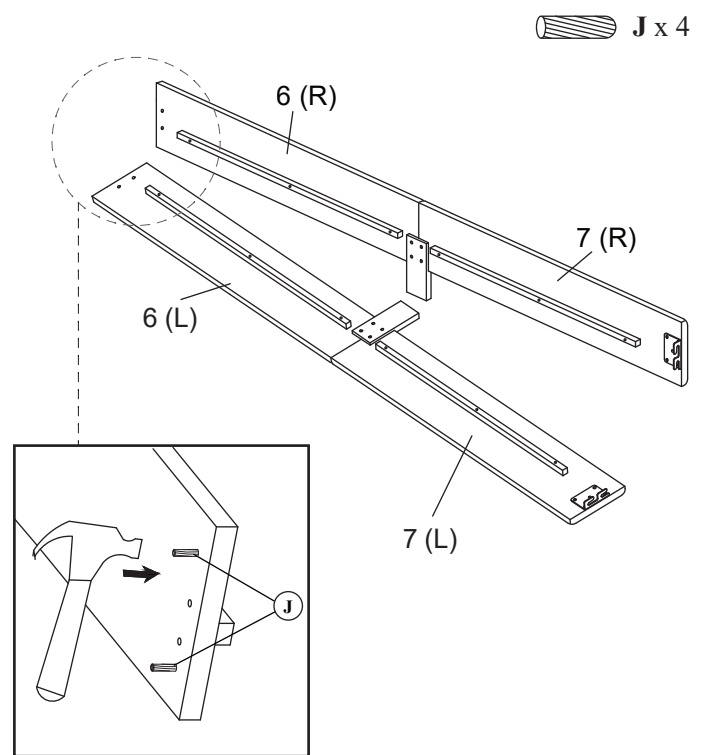

Insert Wood Dowel (J) into the LEFT & RIGHT Headboard Side Rails (6), as shown in picture above; and tap lightly/gently using a Hammer or Rubber Mallet (not included).

STEP 5

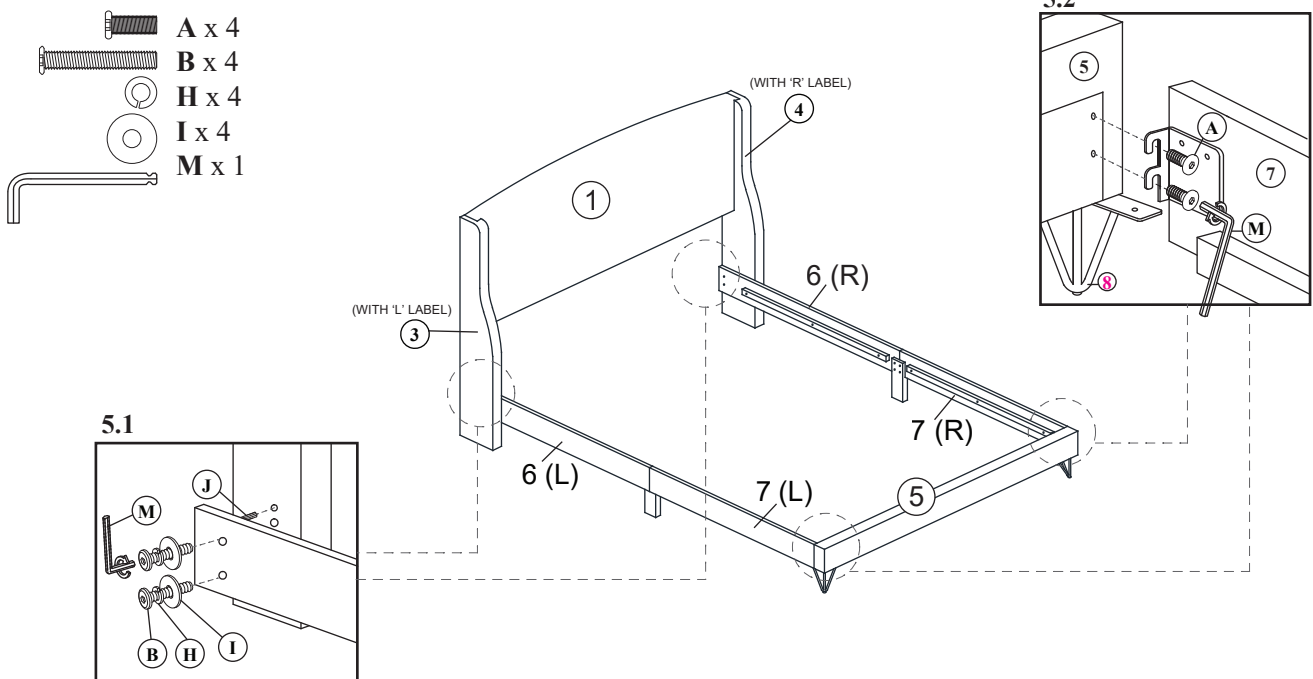

- 5.1** Attach LEFT & RIGHT Headboard Side Rails (6) by inserting the attached Wood Dowel into Left & Right Wing (3 & 4) and secure using Bolt (B), Spring Washer (H), Flat Washer (I) and tighten with L-Key (M).
- 5.2** Attach LEFT & RIGHT Footboard Side Rails (7) to the Footboard (5) using Bolt (A) and secure with L-Key (M), but DO NOT tighten it in all the way.
- Once the Headboard (1) and Footboard (5) are properly attached on the Left & Right Side Rails (6 & 7), tighten all the Bolts.

STEP 6

 **K x 8**

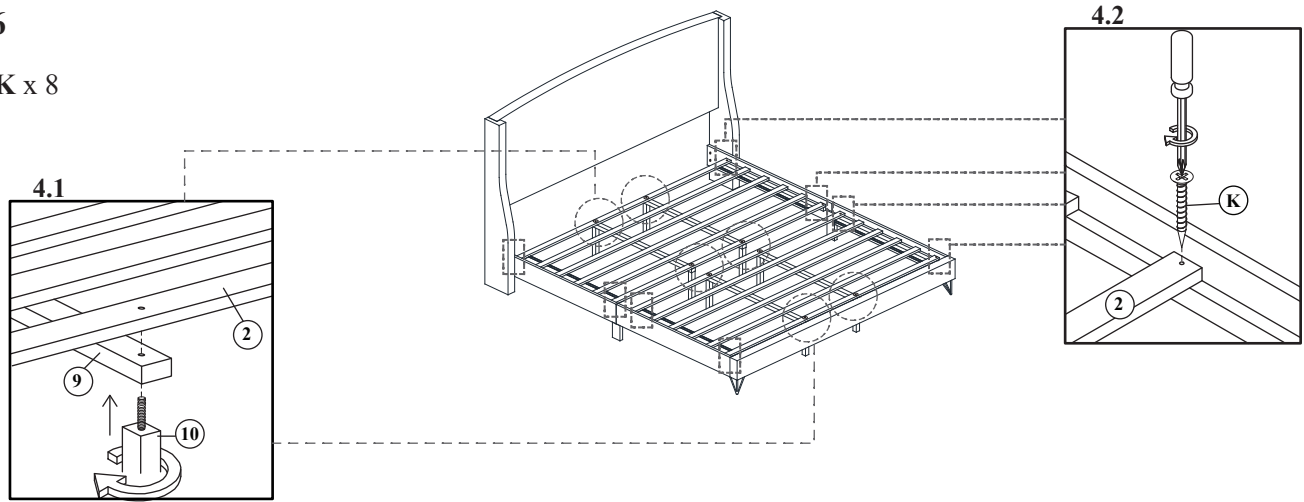

Aligning the holes of Center Rail (9) to Slats (2) and connect using Center Rail Support Leg (10) by turning clockwise until secure. Secure the Slats (2) to the Left & Right Side Rails (6 & 7) using Screw (K) and tighten using Screw Driver (not included).

STEP 7

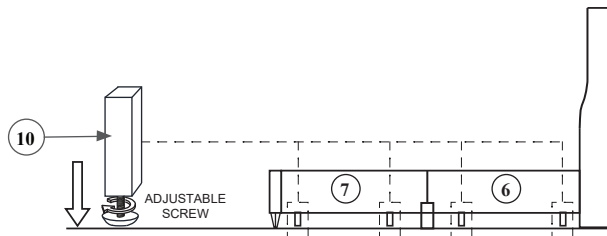

After moving the bed to preferred position, adjust the Center Rail Support Legs (10) leveling straight to the ground.

ASSEMBLY COMPLETED

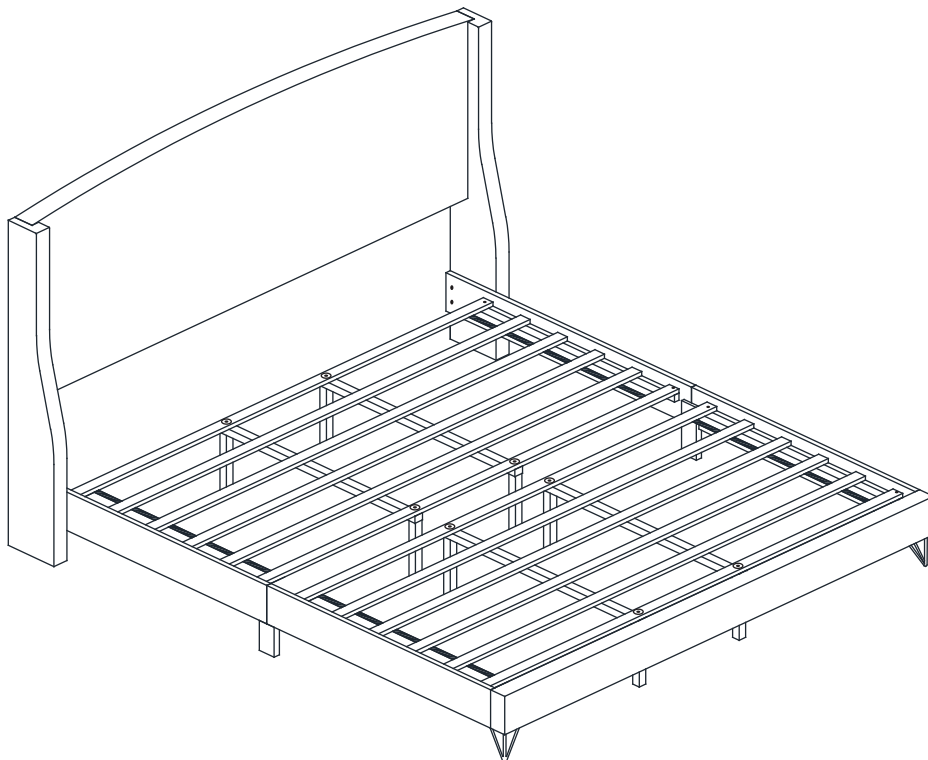

Your Bed is now ready!
Make sure all bolts and screws are fully tightened before using.
DO NOT Jump or Stand on top!