

ASSEMBLY INSTRUCTIONS

DINING TABLE

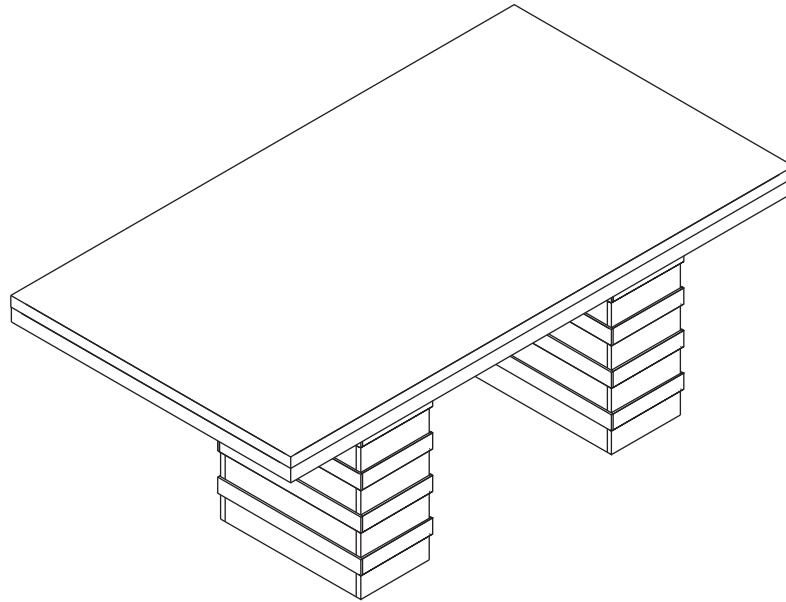



NOTE TO CUSTOMERS:

- For ease and speed of assembly we recommend that before you commence each step of the assembly that you identify all the parts required to complete that step.
- We recommend that where possible you allow sufficient space to assemble the item as close as possible to the place where it will be once assembled.
- For the protection of your furniture we recommend that the product is placed on protected surfaces during assembly to prevent any damage.
- During assembly do not over tighten the screws or bolts, as this may damage the product.
- Please ensure you retain all the product packaging until the item is completely assembled.
- Periodically check all fitting and re-tighten as necessary.
- Never allow any liquids to remain on your furniture as absorption can cause the wood to warp or finish to de-laminate.
- It is recommended that this item should be assembled by two adults.

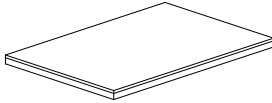
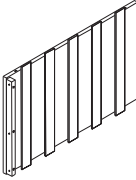
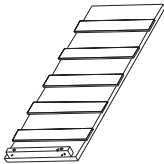
PARTS IDENTIFICATION

A-	Table Top		1 pc
B-	Pedestal Leg Panel (Long)		4 pcs
C -	Pedestal Leg Panel (Short)		4 pcs

HARDWARE IDENTIFICATION

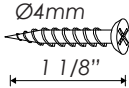
1-	Minifix Connecting Bolt		24 pcs
2-	Minifix Connector Housing		24 pcs
3-	Screws		24 pcs

NOTE: Quantities shown are for one table.

STEP 1 Place pedestal leg panel (C) face down on a soft surface then insert the bolt & tighten with screw driver(NOT INCLUDED) as per diagram shown.

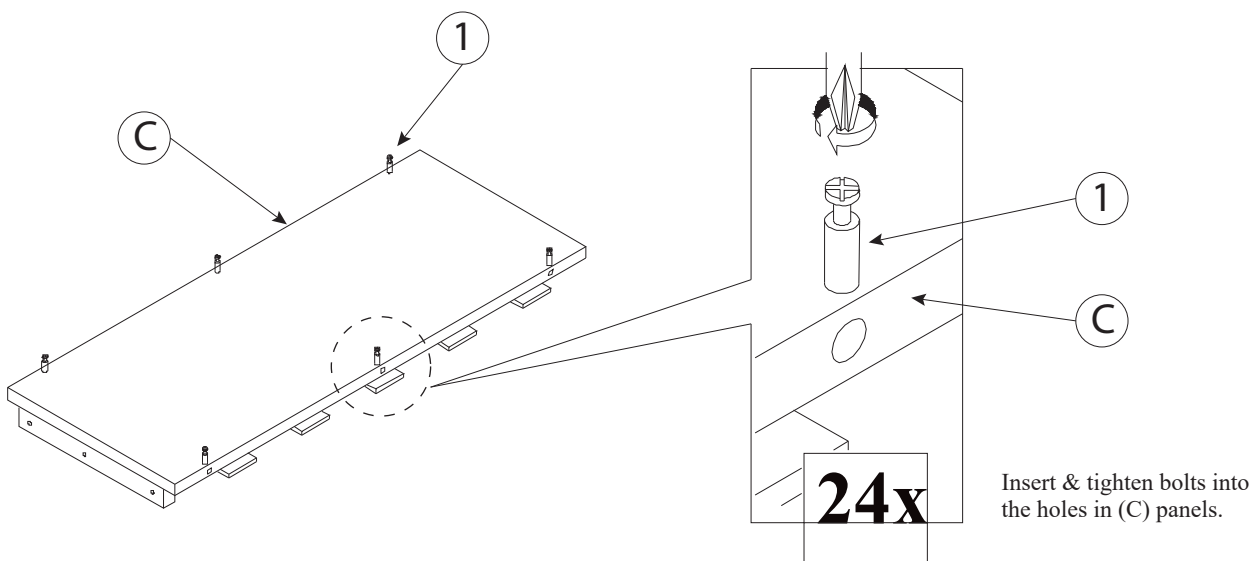

STEP 2 Align & fasten pedestal leg panels (B) by using minifix fittings (2) as per diagram shown. Tighten with screw driver (NOT INCLUDED).

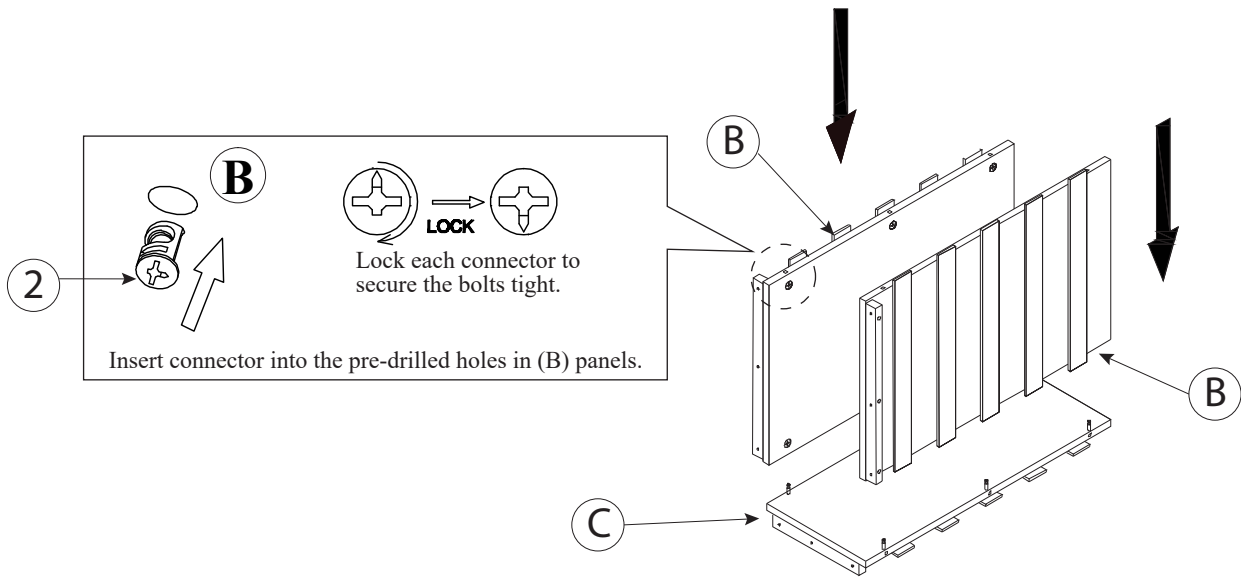

STEP 3 Complete the assembly of one pedestal leg by aligning & fastening the short pedestal leg panel (C) to pedestal leg panels (B), using the connecting fittings. Repeat the assembly process for the second set of the pedestal leg.

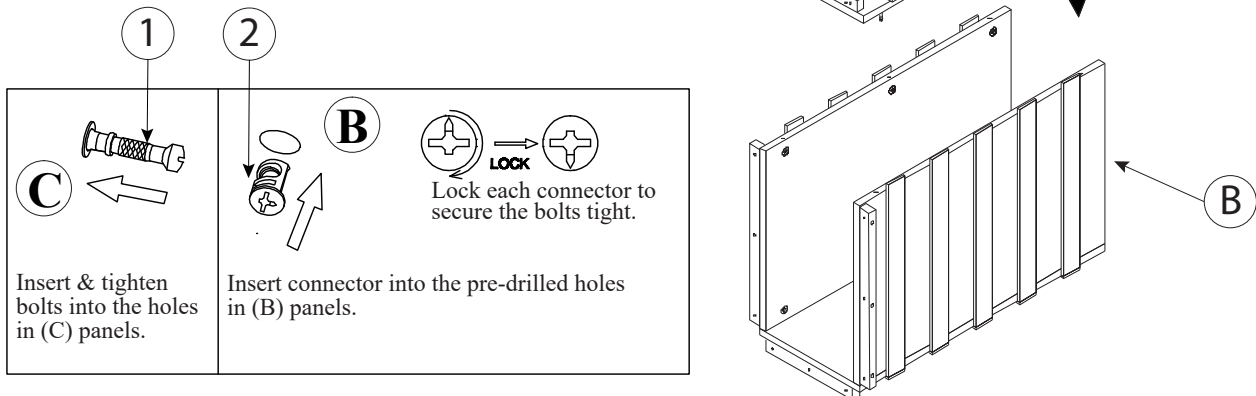

STEP 4 Place Table top upside down. Place both the table base within the marked lines on the table top. Use screws (3) to attach table base to table top. Make sure all screws and connecting bolts are fully tightened before turning the table upright.

