

Instruction Manual



Sofa

Sofa

WARRANTY

WE STRIVE TO OFFER HIGH-QUALITY PRODUCT AND WE ALSO TRY OUR BEST TO SATISFY EACH CUSTOMER THAT ORDERS FROM US WITH PRODUCT OR SERVICE AS NEEDED. EACH CUSTOMER RECEIVES A RECORD OF THEIR ORDER, SUCH AS THE ORDER NUMBER OR ITEM RECEIPT. FOR ANY ITEMS THAT ARE OUT OF THE WARRANTY PERIOD, YOU MAY STILL RECEIVE REPLACEMENT PARTS BY PURCHASING THEM FROM OUR COMPANY IF THEY ARE AVAILABLE.

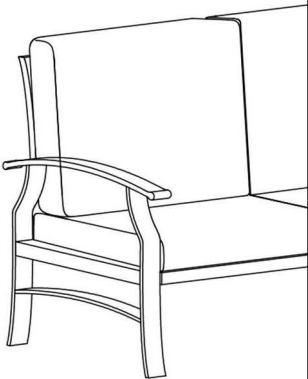

MAINTAINANCE AND WARNING

Please read the manual throughly before
you start install.

Please always use proper tools for
installment.

Packaging and small parts may have
chocking hazard, please keep them away
from children and pets.

Please clean the product with dry clean
cloth, some of the parts may be able to
wash directly. Check with the product
description!

Please keep the product away
from fire.

Please keep the product away from
sharp objects.

IF the product is placed under direct
sunlight, the pattern or color might
fade away.

Do not jump on the product.

Check the product periodically to make
sure everything is tightened.

If you have any questions else, please
contact us,we will be glad to help
you out.

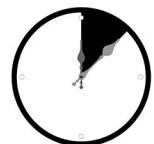

Around 45 min

PRDOUCT DESCRIPTION

This classic outdoor coffee table brings some elegance to your patio or garden.

The table features a rectangular top made from weathered steel-inspired plastic resin, and it sits on a black and brown powder-coated steel base, ensuring its resistance to weather, water, UV rays, rust, and scratches.

With its 100 lbs. weight capacity, this table is perfect for holding your favorite drinks, snacks, and outdoor accessories.

This coffee table adds a timeless touch to your outdoor space without compromising on functionality.

EXPLODED VIEW

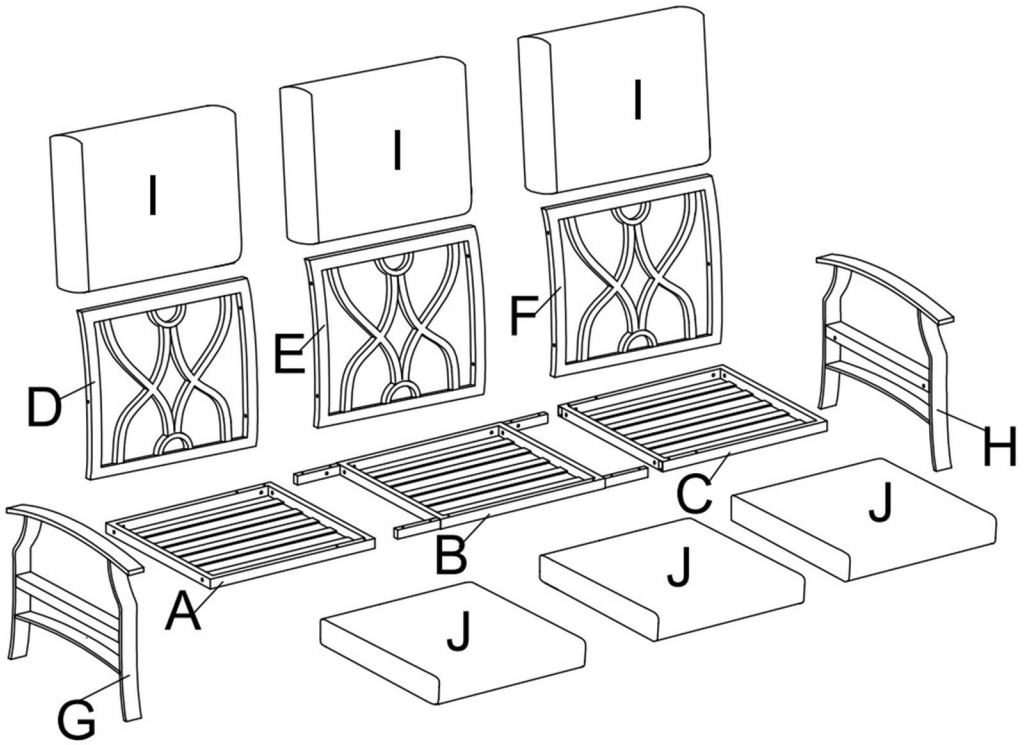

PARTS

A*1



Left seat frame

B*1



Middle seat frame

C*1



Right seat frame

D*1

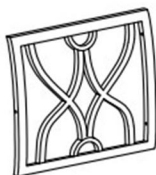

Left backrest

E*1

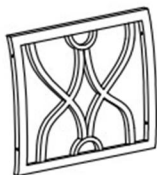

Middle backrest

F*1



Right backrest

G*1



Left arm

H*1



Right arm

I*3

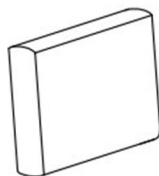

Back cushion

J*3



Seat cushion

K*2



Connecting iron

HARDWARE

TOOL LIST

①*6



★M6*40mm
Bolt

②*20



★M6*35mm
Bolt

③*10



★M6*20mm
Bolt

④*36



★Flat Washer

⑤*1



Allen key

PLEASE MAKE SURE ALL
HARDWARE&PACKING
MATERIAL FITTING THE LIST.
ESPECIALLY SOME SMALL
ACCESSORIES MAY BE MISSING
DURING TRANSPORTATION.
PLEASE CONTACT US
IF YOU HAVE ANY QUESTION.

NOTE: Designated with (★) We provide additional spare parts in the hardware package

step 1

TAKE OUT THE CUSHIONS (I & J) FROM THE COMPRESSION BAGS, AND ALLOW IT TO RECOVER TO ITS ORIGINAL SHAPE, IT MIGHT TAKE UP TO 24 HOURS TO BE FULLY RECOVERED, YOU MAY GENTLY SLAP ON THEM TO SPEED UP THE PROCESS.

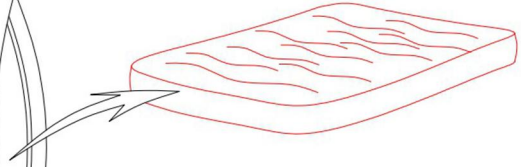
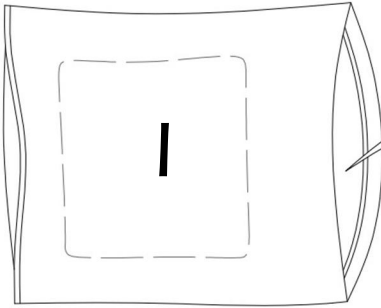

X3

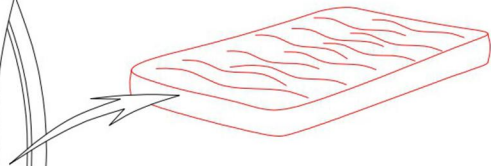
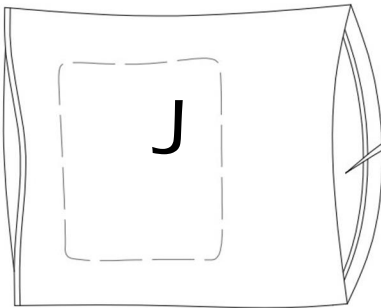

X3

step 2

INSERT LEFT SEAT FRAME (A) AND RIGHT SEAT FRAME (C) INTO THE MIDDLE SEAT FRAME (B) AS SHOWN. MAKE SURE THEY ARE ALL ALIGNED CORRECTLY.

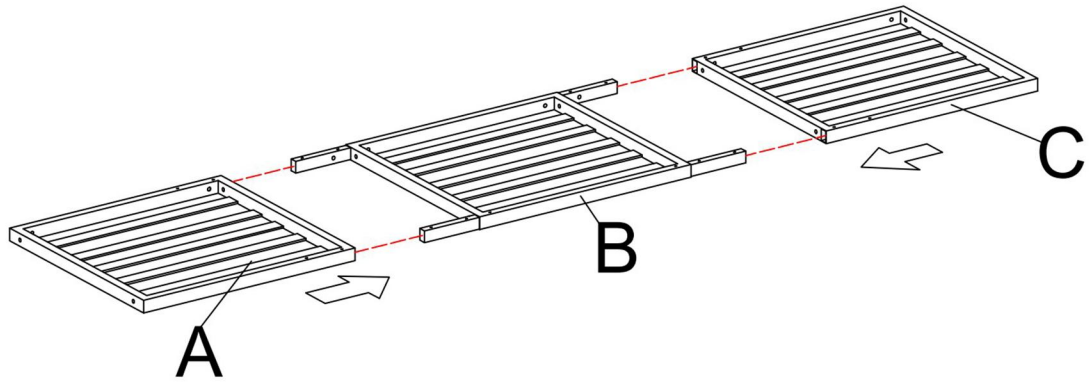

step 3

PLACE ONE FLAT WASHER (4) ONTO EACH BOLT (3), AND USE A PIECE OF CONNECTING IRON (K) TO FIX THE BACK PART OF THE FRAMES AS SHOWN, THERE ARE TWO PIECES OF CONNECTING IRONS WILL BE USED. THEN USE THE ALLEN WRENCH (5) PROVIDED TO TIGHTEN ALL THE BOLTS, MAKE SURE ALL THE PARTS ARE CORRECTLY ALIGNED BEFORE FULLY TIGHTEN THE BOLTS.

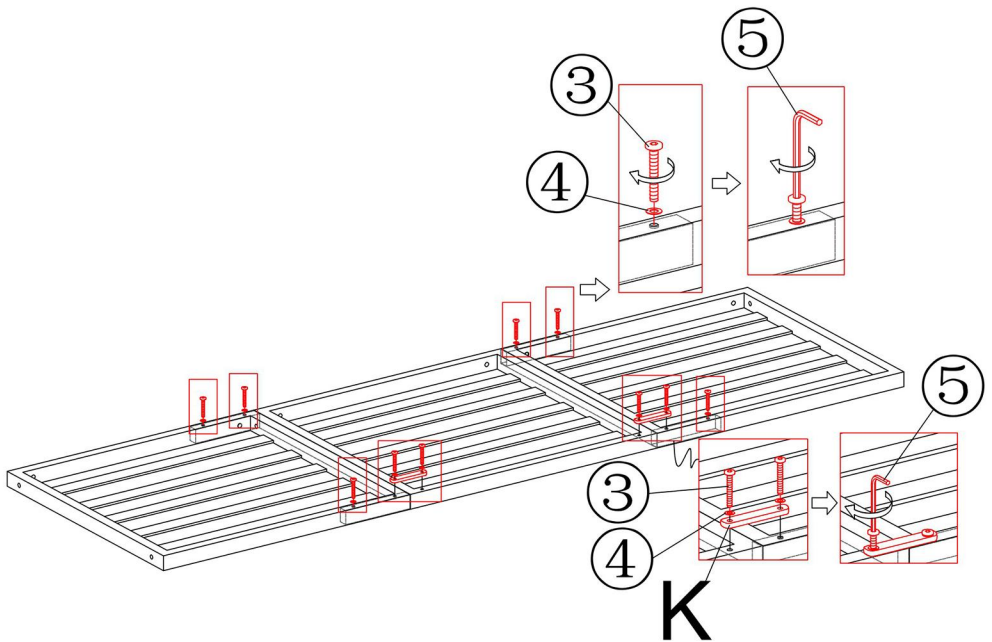

step 4

PLACE ONE FLAT WASHER (4) ONTO EACH BOLT (2), AND USE THE ALLEN WRENCH (5) PROVIDED TO TIGHTEN THE BOLTS AS SHOWN. THE BOLTS ARE LOCATED ON THE INNER SIDES OF THE LEFT AND RIGHT FRAME, MAKE SURE ALL 10 BOLTS ARE CORRECTLY ALIGNED BEFORE FULLY TIGHTEN THEM.

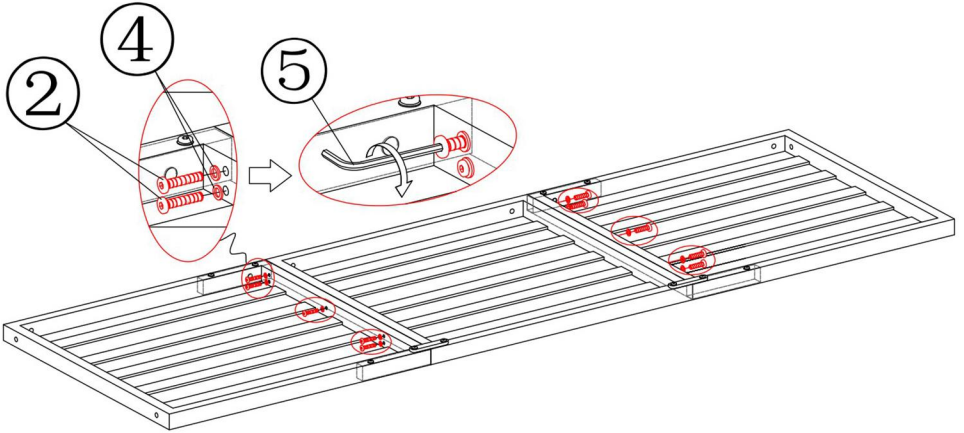

step 5

ALIGN THE PREDRILLED HOLES ON BACKREST WITH THE SEAT FRAME , ADD ONE WASHER (4) ON EACH BOLT (2) AS SHOWN, THEN ALIGN THE BOLT HOLES ON BOTH SEAT FRAME AND RIGHT ARMREST, THEN USE THE ALLEN WRENCH (5) PROVIDED TO TIGHTEN ALL BOLTS BY 30%-50% AT FIRST, ENSURING THAT ALL BOLTS ARE ALIGNED CORRECTLY BEFORE TIGHTENING ALL BOLTS.

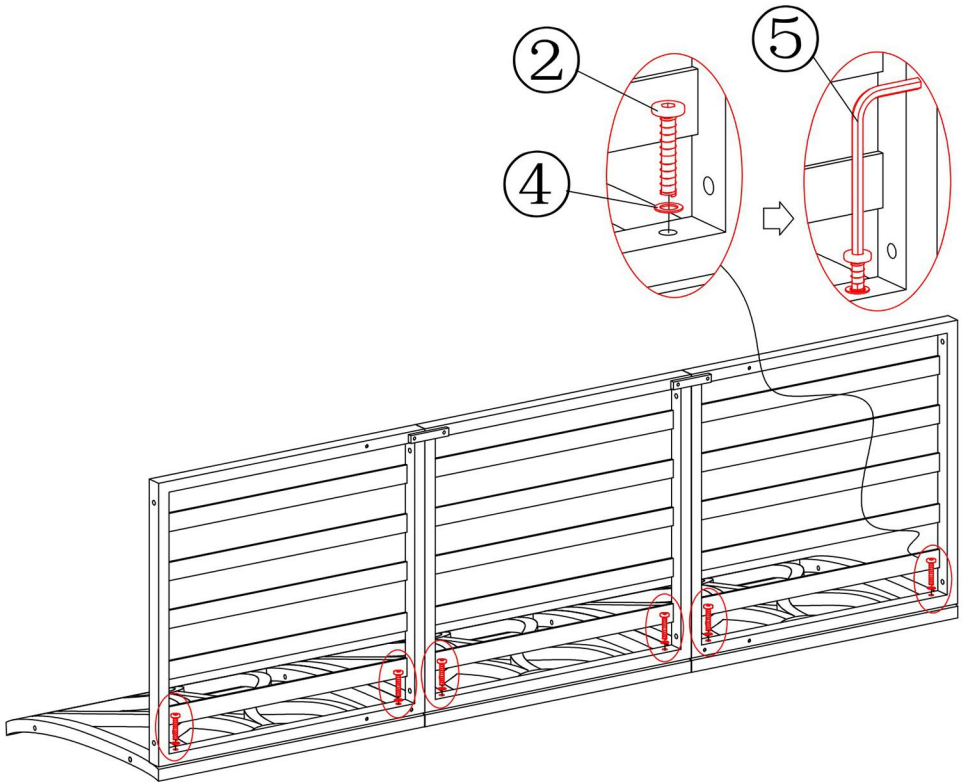

step 6

PLACE ONE FLAT WASHER (4) ONTO EACH BOLT (1), AND USE THE ALLEN WRENCH (5) PROVIDED TO TIGHTEN THE BOLTS AS SHOWN. THE BOLTS ARE LOCATED ON THE INNER SIDES OF THE BACKREST, MAKE SURE ALL 4 BOLTS ARE CORRECTLY ALIGNED BEFORE FULLY TIGHTEN THEM.

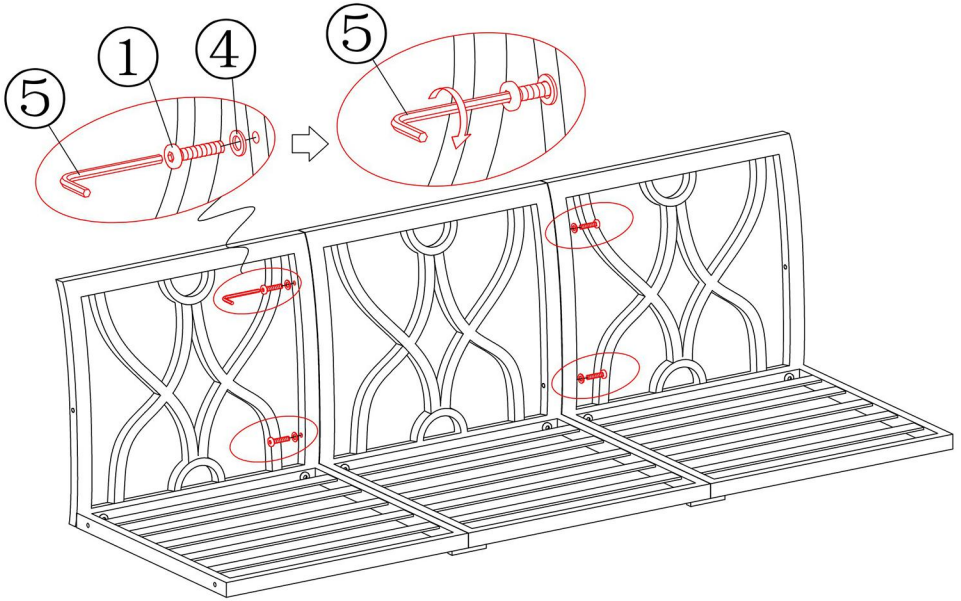

step 7

INSTALL THE LEFT ARMREST (G) ONTO THE FRAME, ADD ONE FLAT WASHER (4) ON EACH BOLT (1& 2) AS SHOWN, THEN ALIGN THE BOLT HOLES ON BOTH FRAME AND LEFT ARMREST (G), USE BOLT (1) TO CONNECT BACK FRAME AND THE LEFT ARMREST, USE BOLT (2) TO CONNECT SEAT FRAME AND LEFT ARMREST, THEN USE THE ALLEN WRENCH (5) PROVIDED TO TIGHTEN THE BOLTS BY 30-50% AT FIRST, ENSURING THAT ALL BOLTS ARE ALIGNED CORRECTLY BEFORE FULLY TIGHTENING.

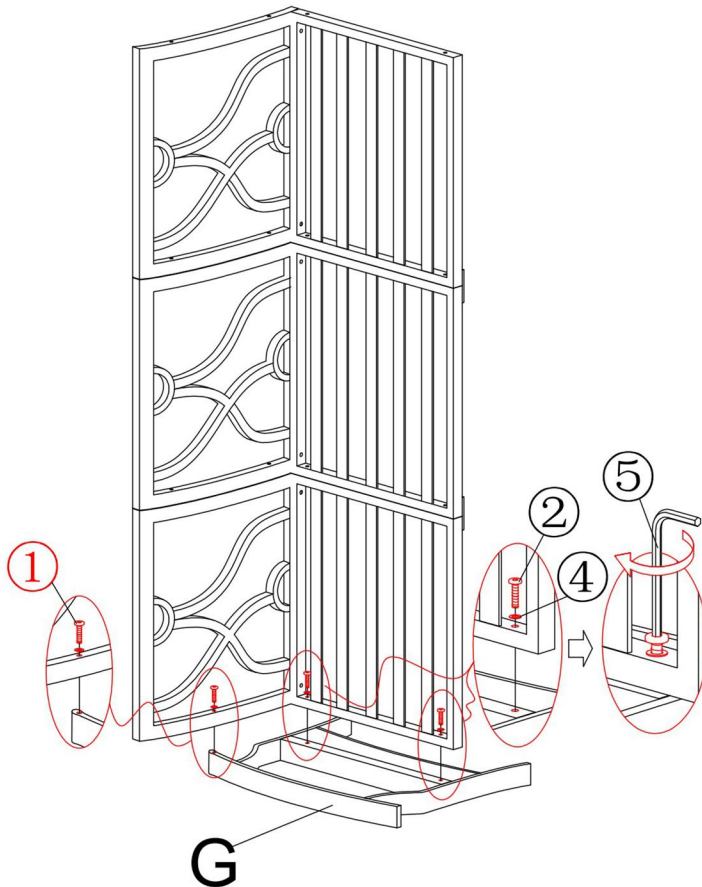

step 8

INSTALL THE RIGHT ARMREST (H) ONTO THE FRAME, ADD ONE FLAT WASHER (4) ON EACH BOLT (1 & 2) AS SHOWN, THEN ALIGN THE BOLT HOLES ON BOTH FRAME AND RIGHT ARMREST (H), USE BOLT (1) TO CONNECT BACK FRAME AND THE LEFT ARMREST, USE BOLT (2) TO CONNECT SEAT FRAME AND LEFT ARMREST, THEN USE THE ALLEN WRENCH (5) PROVIDED TO TIGHTEN THE BOLTS BY 30-50% AT FIRST, ENSURING THAT ALL BOLTS ARE ALIGNED CORRECTLY BEFORE FULLY TIGHTENING.

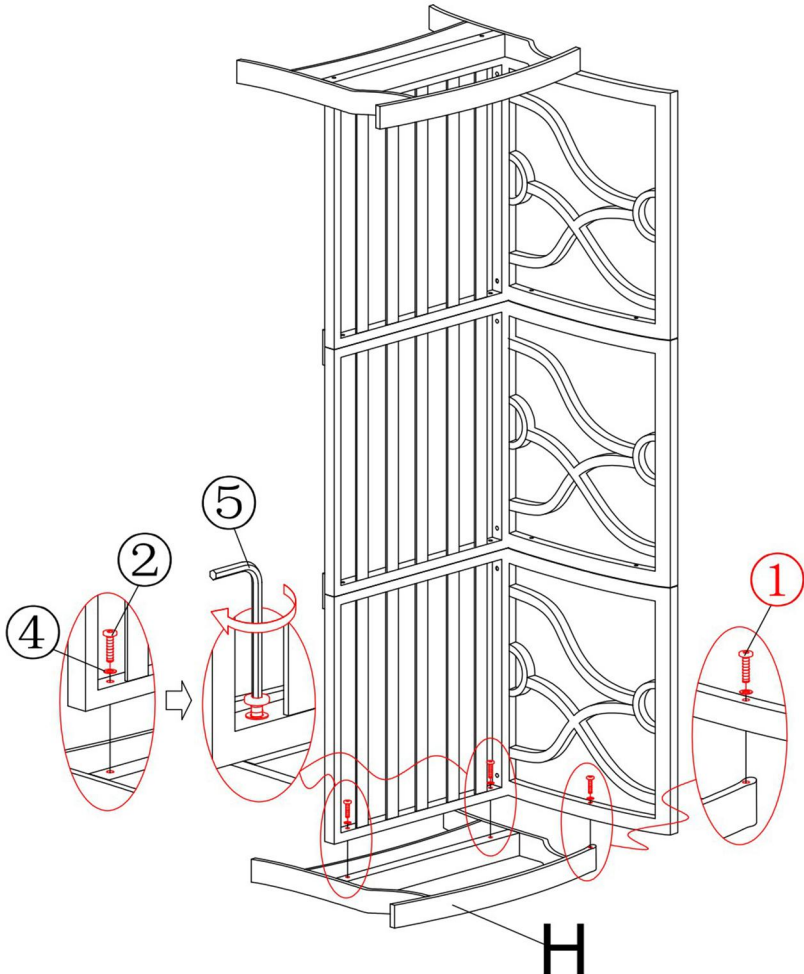

step 9

PLACE THE SEAT CUSHION (J) ONTO THE CHAIR.

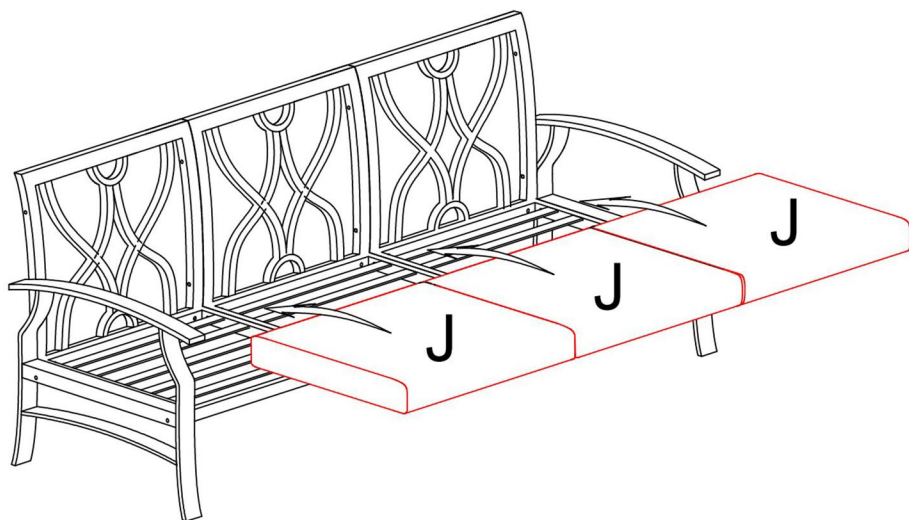

step 10

PLACE THE BACK CUSHION (1) ONTO THE CHAIR.

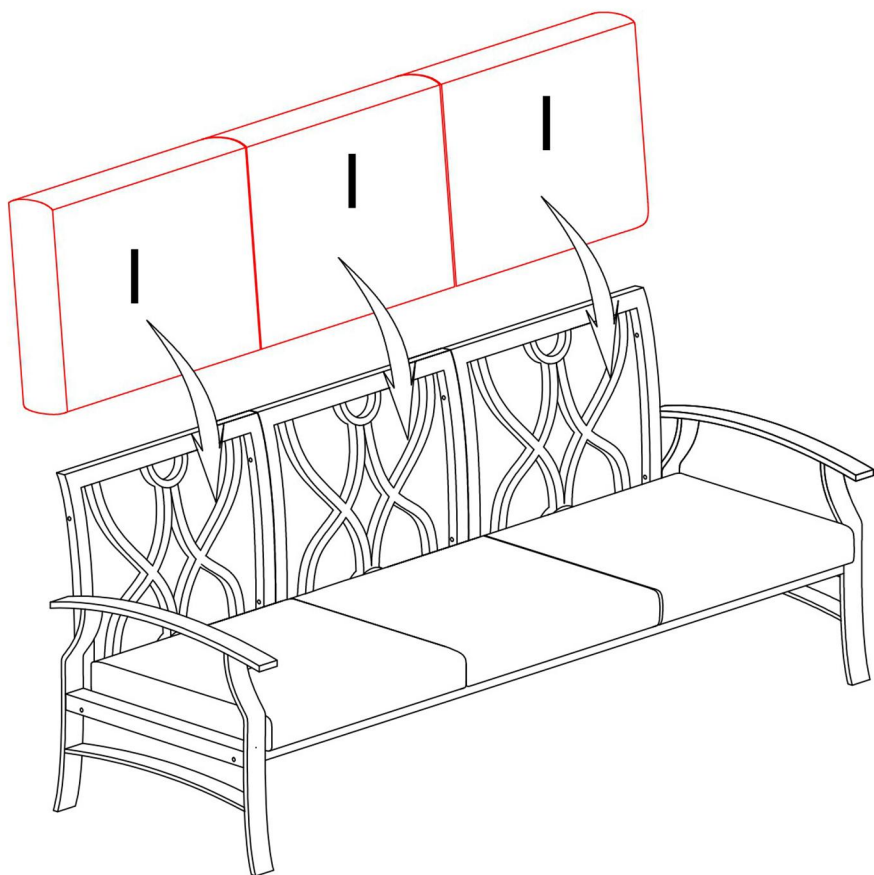

step 11

THE ASSEMBLY IS COMPLETE! THANKS FOR CHOOSING OUR PRODUCT!
PLEASE ENJOY!

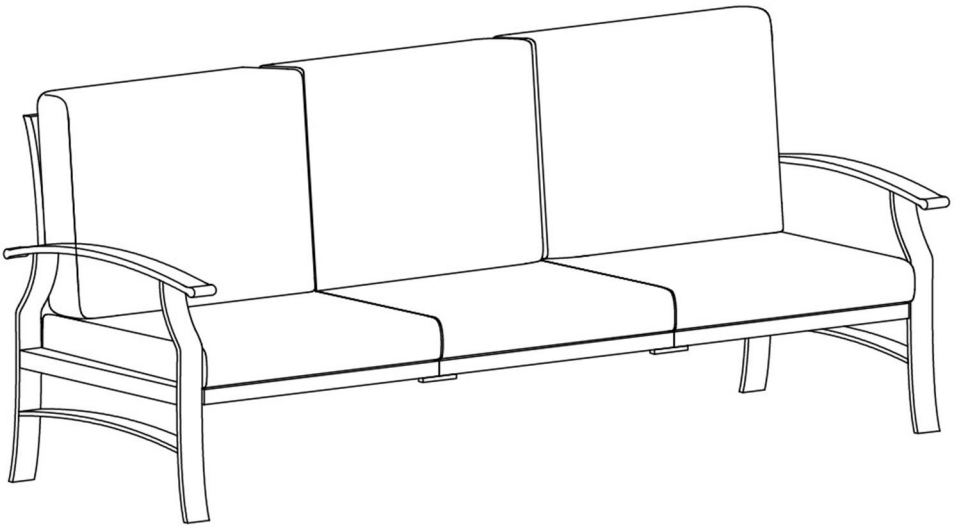

For better user experience, please carefully check all the screws, and make sure they are all fully tightened. (Use the allen wrench to twist each screw until it is fully tightened.)