



INSTRUCTIONS D'ASSEMBLAGE ASSEMBLY INSTRUCTIONS

**TABLE D'APPOINT -
48" L / CONSOLE D'ENTREE NOIR**





**ACCENT TABLE -
48" L / BLACK / BLACK METAL HALL CONSOLE**





**POUR DE L'ASSISTANCE OU POUR COMMANDER
DES PIÈCES CONTACTEZ NOTRE DÉPARTEMENT
DE SERVICE À LA CLIENTÈLE.**

**FOR ASSISTANCE OR TO ORDER PARTS
CONTACT OUR CUSTOMER SERVICE DEPARTMENT**



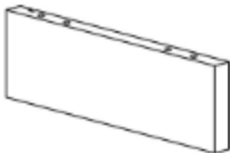
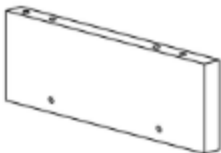
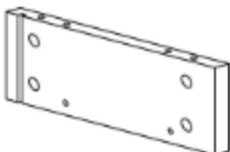

LISTE DES PIÈCES
PARTS LIST

PIÈCE / PART #	IMAGE	DESCRIPTION	QTY / QTÉ
1		FRONT FACING LEFT LEG PATTE AVANT GAUCHE	1
2		CROSSBAR BARRE TRANSVERSALE	2
3		CROSSBAR BARRE TRANSVERSALE	2
4		FRONT FACING RIGHT LEG PATTE AVANT DROITE	1
5		BOTTOM PANEL PANNEAU DU BAS	1

LISTE DES PIÈCES
PARTS LIST

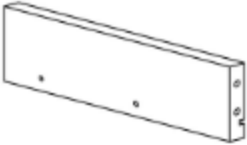
PIÈCE / PART #	IMAGE	DESCRIPTION	QTY / QTÉ
6		FRONT FACING LEFT SIDE PANEL PANNEAU DE CÔTÉ GAUCHE	1
7		DIVIDER PANEL PANNEAU DE DIVISION	1
8		FRONT FACING RIGHT SIDE PANEL PANNEAU DE CÔTÉ AVANT DROIT	1
9		BACK PANEL PANNEAU ARRIÈRE	1
10		TOP PANEL PANNEAU DE SURFACE	1

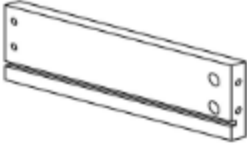

LISTE DES PIÈCES
PARTS LIST

PIÈCE / PART #	IMAGE	DESCRIPTION	QTY / QTÉ
11		DRAWER SIDE PANEL PANNEAU DE CÔTÉ TIROIR	2
12		DRAWER BACK PANEL PANNEAU ARRIÈRE TIROIR	2
13		DRAWER SIDE PANEL PANNEAU DE CÔTÉ TIROIR	2
14		DRAWER BOTTOM PANEL PANNEAU DU BAS TIROIR	2
15		DRAWER FRONT PANEL PANNEAU AVANT TIROIR	1



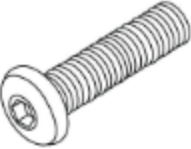
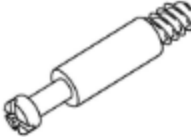
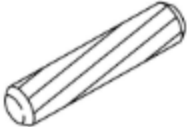

LISTE DES PIÈCES
PARTS LIST

PIÈCE / PART #	IMAGE	DESCRIPTION	QTY / QTÉ
16		DRAWER FRONT PANEL PANNEAU AVANT TIROIR	1

LISTE DES PIÈCES DE MONTAGE
HARDWARE LIST

PIÈCE / PART #	IMAGE	DESCRIPTION	QTY / QTÉ
A		ASSEMBLING BOLT - 1 1/2" BOULON D'ASSEMBLAGE - 1 1/2"	8
B		CAM LOCK SCREW VIS CAM LOCK	28
C		WOOD DOWEL GOUJON DE BOIS	12
D		CAM LOCK CONNECTOR ÉCROU CAM LOCK	28
E		ASSEMBLING SCREW - 1/2" VIS D'ASSEMBLAGE - 1/2"	16

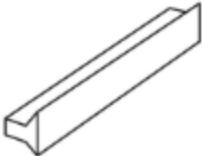
LISTE DES PIÈCES DE MONTAGE
HARDWARE LIST

PIÈCE / PART #	IMAGE	DESCRIPTION	QTY / QTÉ
F		METAL DRAWER SLIDE COULISSE DE MÉTAL	2
G		METAL DRAWER SLIDE COULISSE DE MÉTAL	2
H		HANDLE POIGNÉE	2
I		ASSEMBLING BOLT - 3/4" BOULON D'ASSEMBLAGE - 3/4"	4
J		ASSEMBLING BOLT - 1 1/8" BOULON D'ASSEMBLAGE - 1 1/8"	4

LISTE DES PIÈCES DE MONTAGE
HARDWARE LIST

PIÈCE / PART #	IMAGE	DESCRIPTION	QTY / QTÉ
K		HEX KEY CLÉ HEXAGONALE	1



**OUTIL DE VÉRIFICATION DE DIMENSIONS DES PIÈCES
HARDWARE DIMENSIONS VERIFICATION TOOL**



ÉTAPE / STEP 1

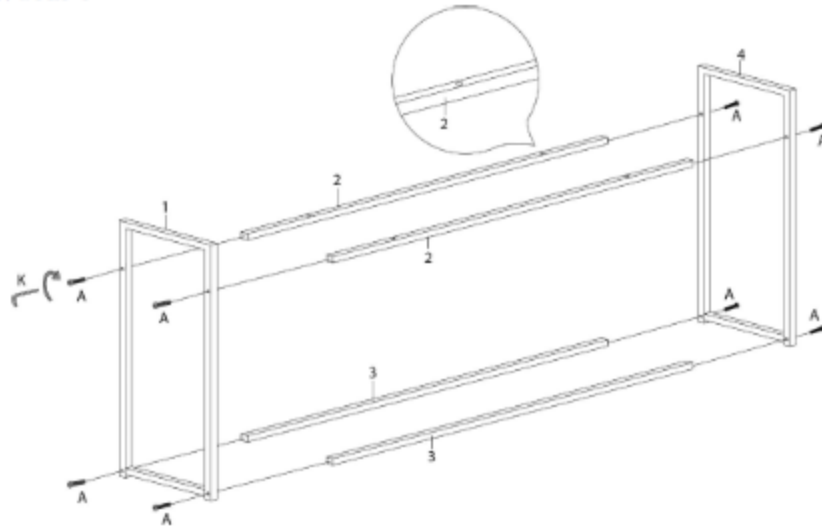

ÉTAPE / STEP 2

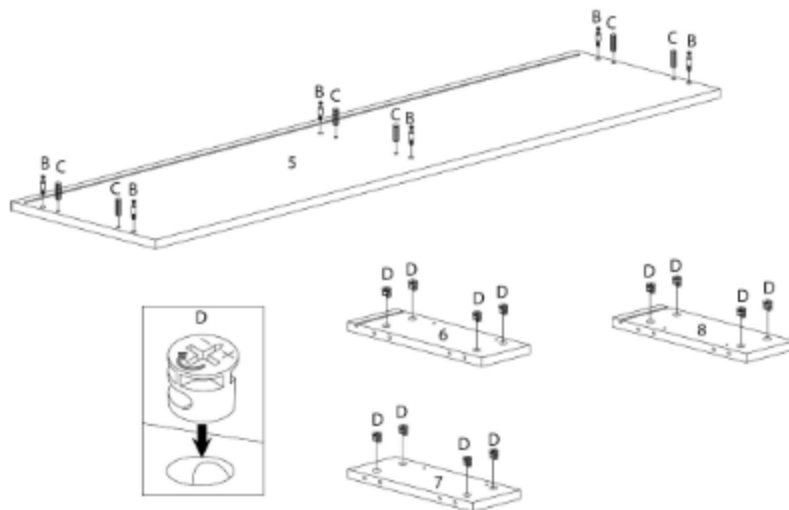

ÉTAPE / STEP 5

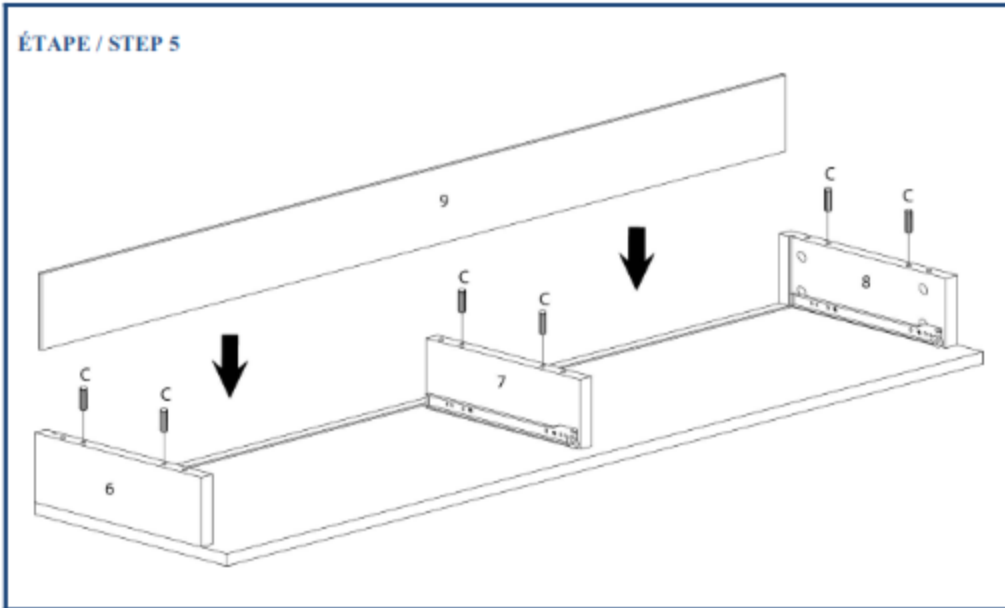

ÉTAPE / STEP 6

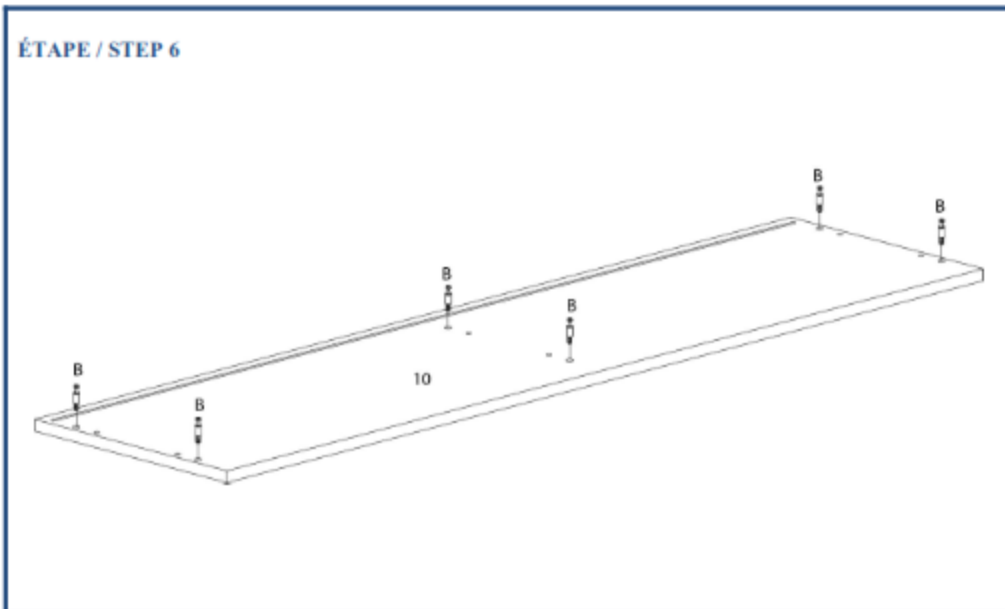

ÉTAPE / STEP 7

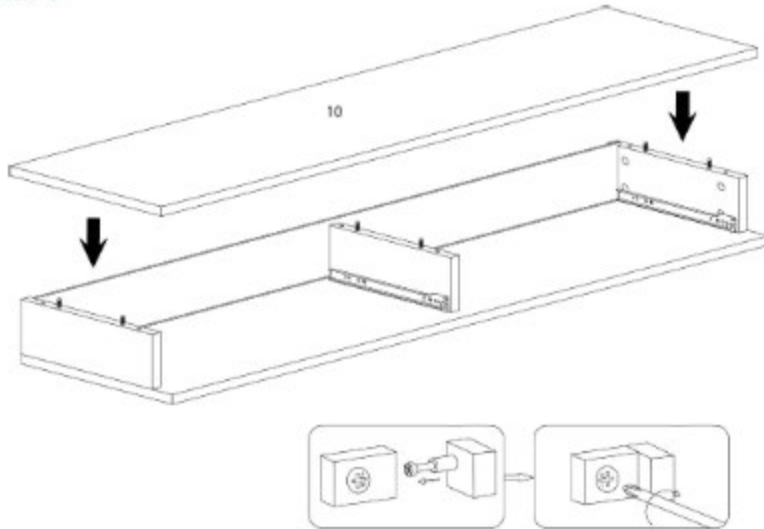

ÉTAPE / STEP 8

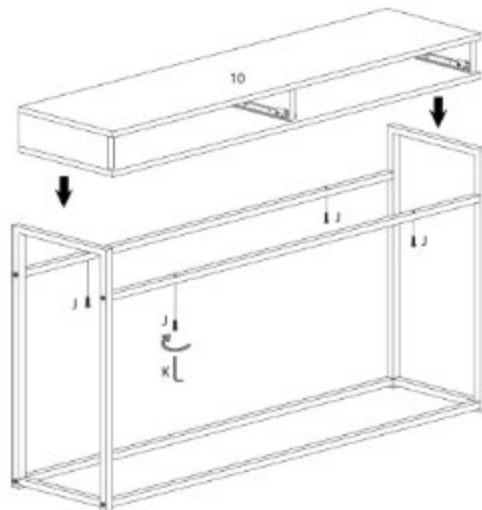

ÉTAPE / STEP 9

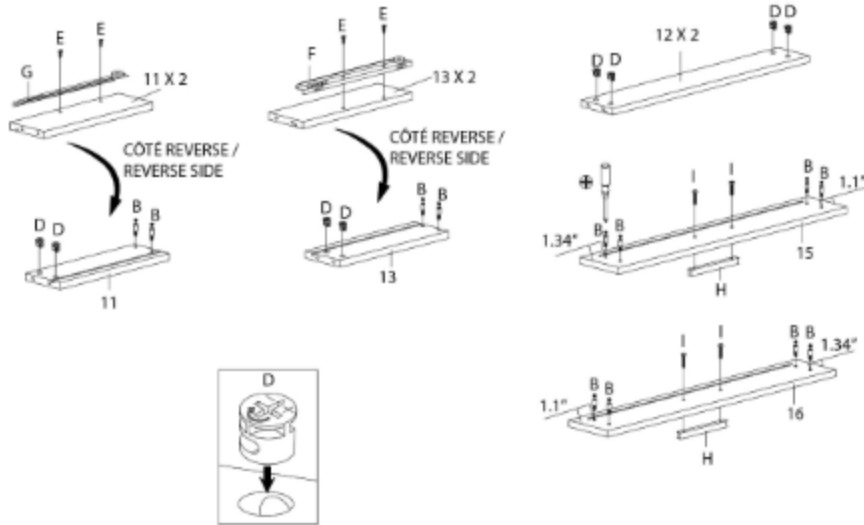

ÉTAPE / STEP 10

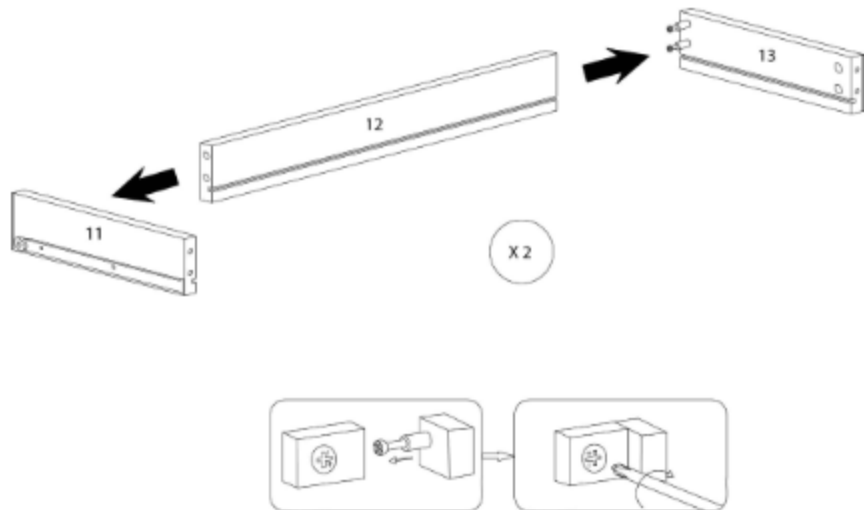

ÉTAPE / STEP 11

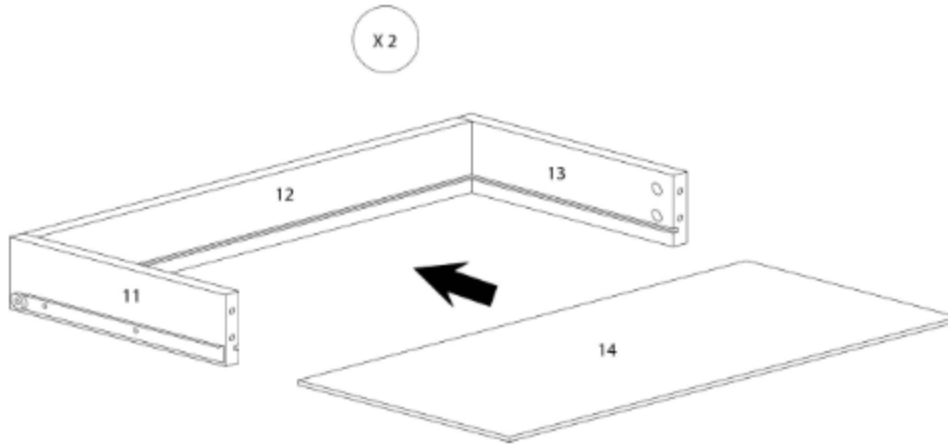

ÉTAPE / STEP 12

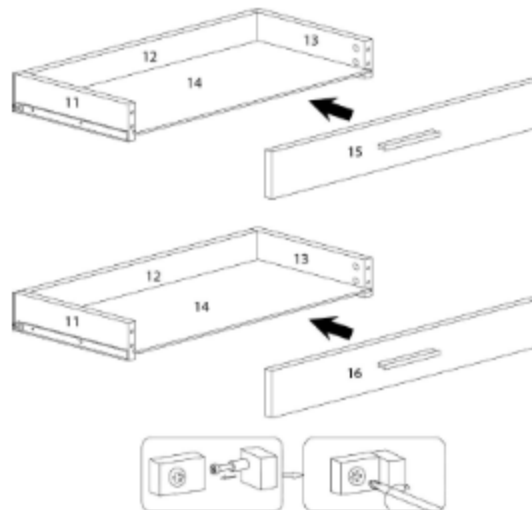

ÉTAPE / STEP 13

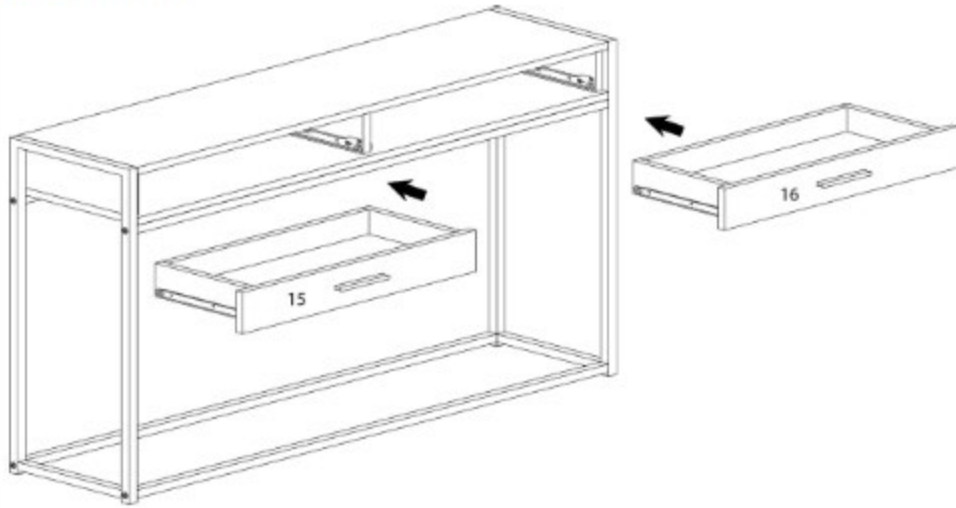

ÉTAPE / STEP 14

