

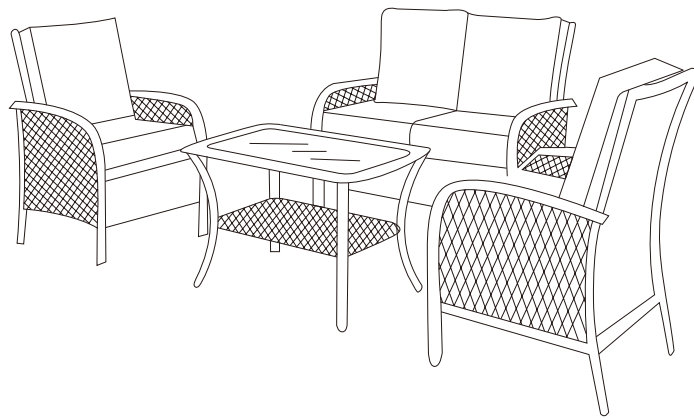

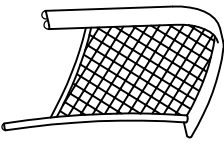

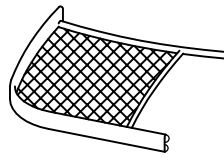

Outdoor Wicker Conversation Set

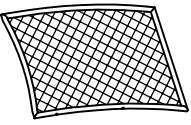
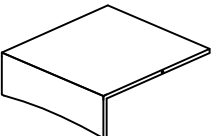
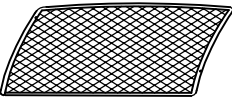
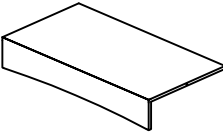

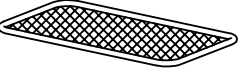
PART LIST

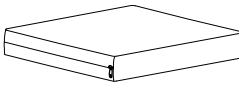
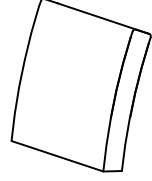
A 	B 	C  (arm chair)	D  (arm chair)	E  (loveseat)
Left Arm Panel 3 PCS	Right Arm Panel 3 PCS	Back Panel 2 PCS	Seat Panel 2 PCS	Back Panel 1 PC
F  (loveseat)	G 	H 	I 	J 
Seat Panel 1 PC	Top Panel 1 PC	Leg 4 PCS	Shelf 1 PC	Glass Top 1 PC
K 	L 			
Seat Cushion 4 PCS	Back Cushion 4 PCS			

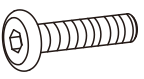
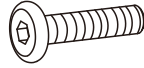
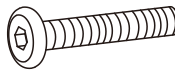
HARDWARE LIST

#1  M6*15mm	#2  M6*30mm	#3  M6*40mm	#4  M6mm	#5  M6mm
Short Bolt 8 PCS (Extra 1)	Medium Bolt 18 PCS (Extra 2)	Long Bolt 20 PCS (Extra 2)	Flat Washer 46 PCS (Extra 2)	Allen Wrench 1 PC

Step 1. Lay left arm panel (part A) down on a soft flat surface, such as carpet, as shown below. Attach back panel (part C) to left arm panel (part A) using long bolts (part #3), flat washers (part #4) and allen wrench (part #5).

NOTE: Please do not fully tighten bolts until unit is fully assembled.

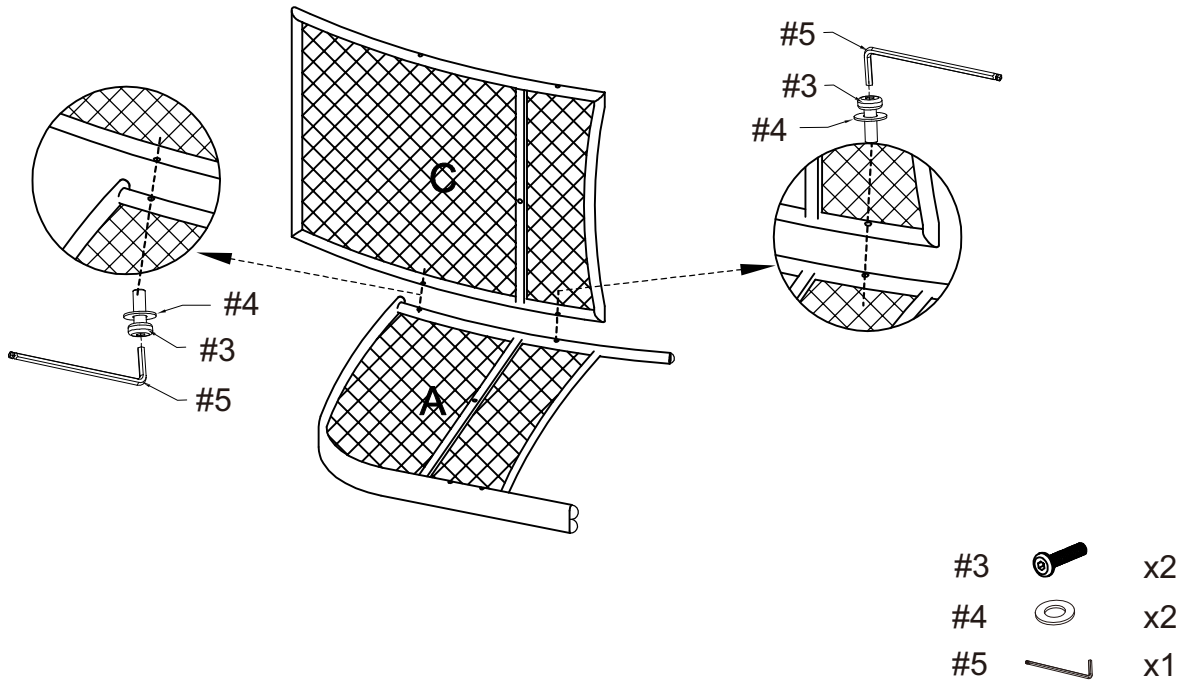

Step 2. Attach seat panel (part D) to left arm panel (part A) and back panel (part C) using medium bolts (part #2), long bolt (part #3), flat washers (part #4) and allen wrench (part #5).

NOTE: Please do not fully tighten bolts until unit is fully assembled.

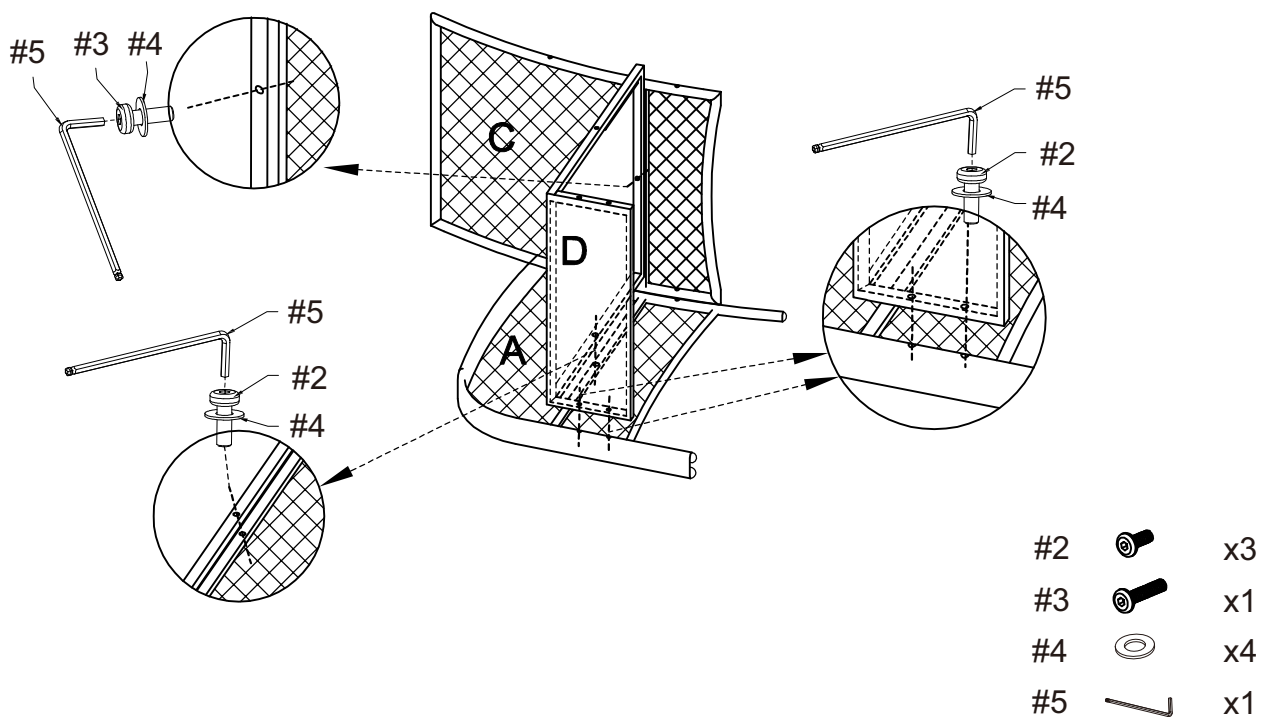

Step 3. Attach right arm panel (part B) to assembled unit (parts A, C & D) using medium bolts (part #2) long bolts (part #3), flat washers (part #4) and allen wrench (part #5).

NOTE: Please fully tighten all bolts at this time.

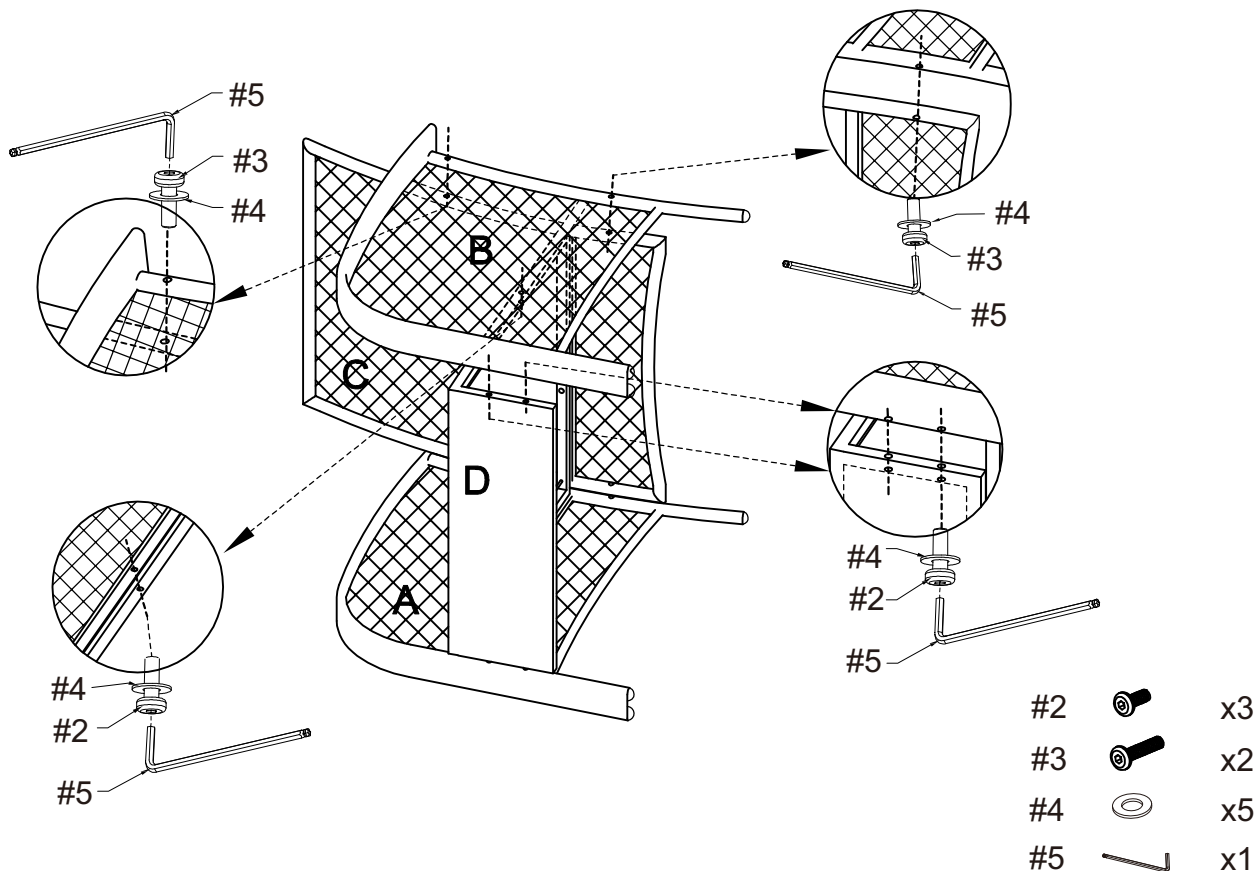

Step 4. Carefully turn unit upright. Place seat cushion (part K) and back cushion (part L) as shown below.

Repeat steps 1-4 to assemble remaining chair.

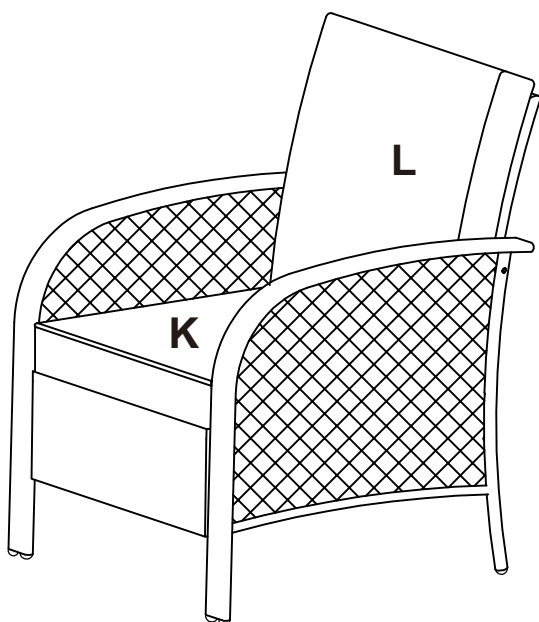

Step 5. Lay left arm panel (part A) down on a soft flat surface, such as carpet, as shown below. Attach back panel (part E) to left arm panel (part A) using long bolts (part #3), flat washers (part #4) and allen wrench (part #5).

NOTE: Please do not fully tighten bolts until unit is fully assembled.

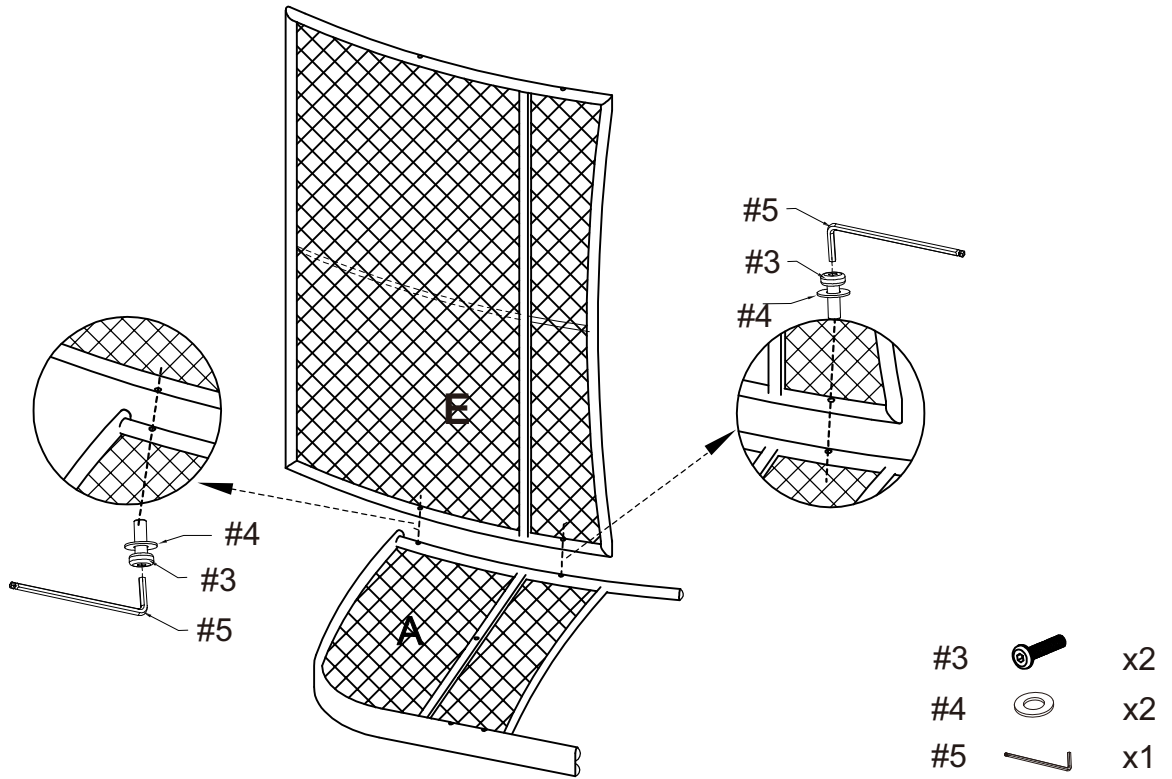

Step 6. Attach seat panel (part F) to left arm panel (part A) and back panel (part E) using medium bolts (part #2), long bolts (part #3), flat washers (part #4) and allen wrench (part #5).

NOTE: Please do not fully tighten bolts until unit is fully assembled.

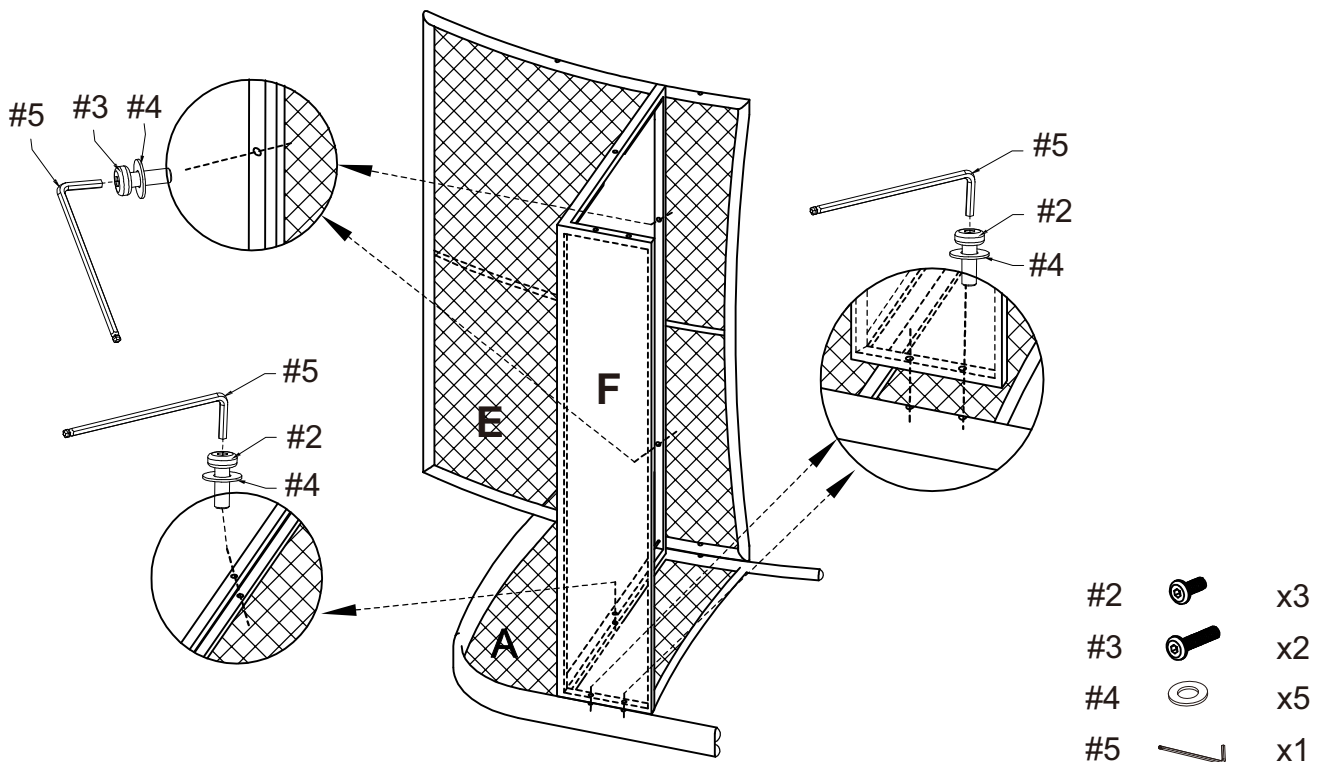

Step 7. Attach right arm panel (part B) to assembled unit (parts A, E & F) using medium bolts (part #2) long bolts (part #3), flat washers (part #4) and allen wrench (part #5).

NOTE: Please fully tighten all bolts at this time.

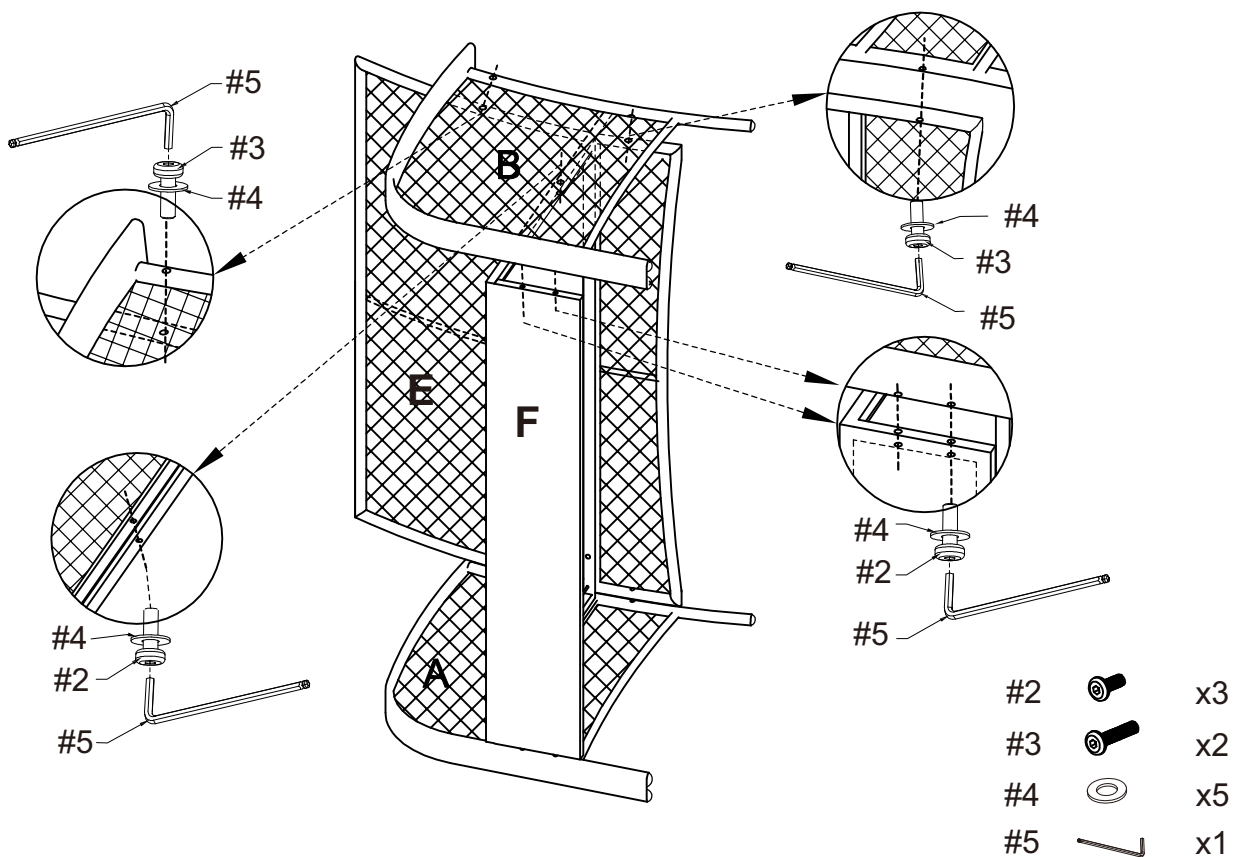

Step 8. Carefully turn unit upright. Place seat cushions (part K) and back cushions (part L) as shown below.

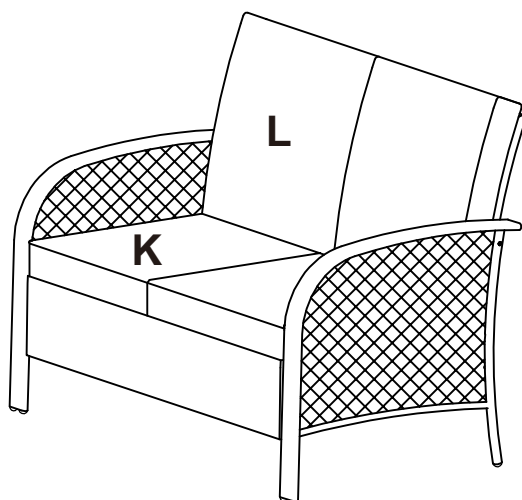

Step 9. Lay top panel (part G) down on a soft flat surface, such as carpet, as shown below. Attach legs (part H) to top panel (part G) using short bolts (part #1), flat washers (part #4) and allen wrench (part #5).

NOTE: Please do not fully tighten bolts until unit is fully assembled.

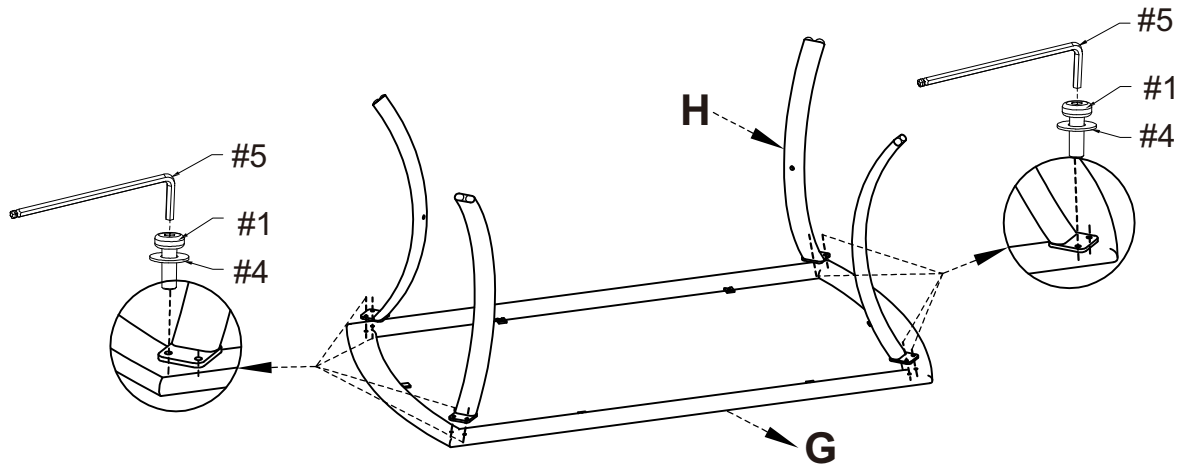



- | | | |
|----|--|----|
| #1 |  | x8 |
| #4 |  | x8 |
| #5 |  | x1 |

Step 10. Attach shelf (part I) to legs (part H) using long bolts (part #3), flat washers (part #4) and allen wrench (part #5).

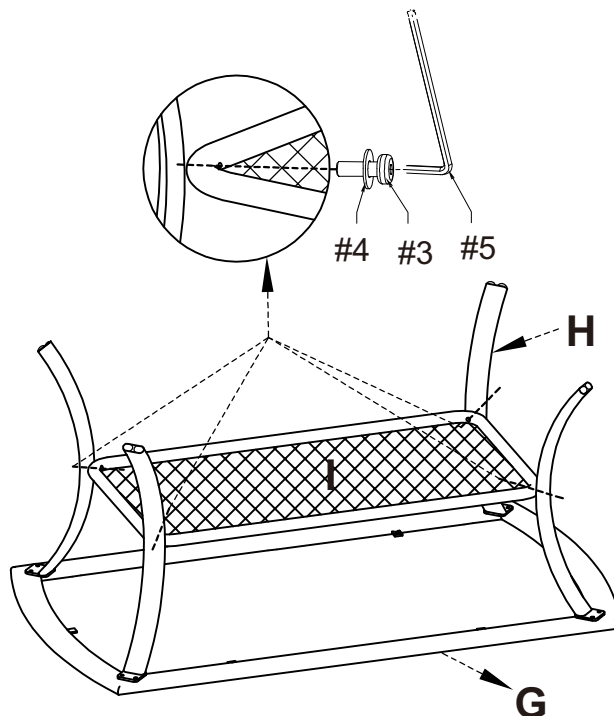
NOTE: Please fully tighten all bolts at this time.



- | | | |
|----|---|----|
| #3 |  | x4 |
| #4 |  | x4 |
| #5 |  | x1 |

Step 11. Turn the table upright and gently place glass top (part J) on holders of top panel (part G).

