

TOOLS REQUIRED:

SAFETY GLASSES

GLOVES

3/16" HEX HEAD HAND OR POWER TOOL

92-0815XX, 92F0815XX REPLACEMENT SEAT ASSY

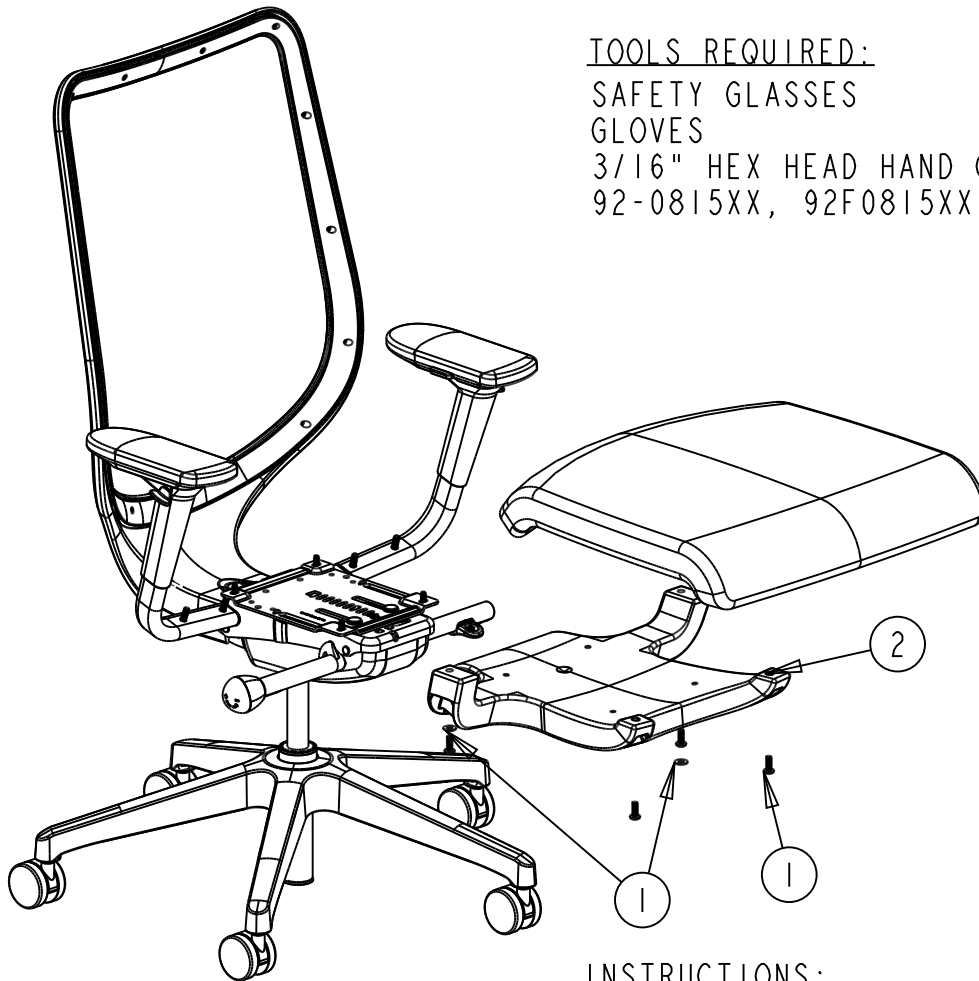

INSTRUCTIONS:

1. REMOVE (4) SEAT ASSEMBLY SCREWS (50-8392) FROM CONTROL SPIDER, USING 3/16" HEX HEAD HAND OR POWER TOOL. THE TWO REAR SPIDER SEAT SCREWS ALSO HAVE (1) WASHER (50-8396) PER SCREW THAT WILL NEED TO BE REMOVED WITH THE SCREWS AS WELL.
2. CENTER REPLACEMENT SEAT ASSY (92-0815XX, 92F0815XX) SCREW LOCATIONS ON CHAIR SPIDER HOLE. ALIGN SEAT ASSY HOLES AS INDICATED IN ITEM 2.
3. USE 3/16" HEX HEAD HAND OR POWER TOOL TO SECURE (4) SEAT ASSEMBLY SCREWS INTO CHAIR SPIDER. MAKE SURE TO INSTALL (1) WASHER (50-8396) TO EACH REAR SCREW (2 TOTAL). USE 135-145 IN-LBS OF TORQUE WHEN SECURING SCREWS TO REPLACEMENT SEAT ASSEMBLY.

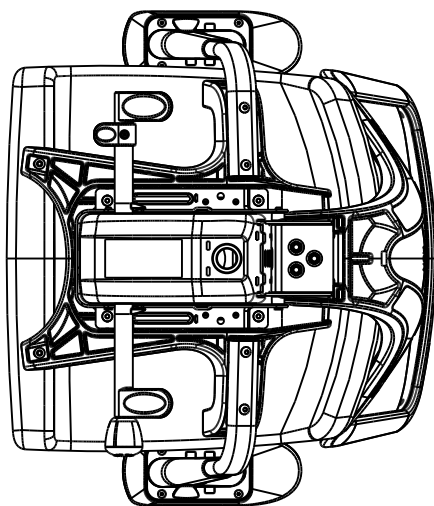

BASE SIDE UP - VIEW