

KJEC-250009 BGD2304-50-X说明书英标2026.1.9
145x210mm

DAHTEC®

DEHUMIDIFIER

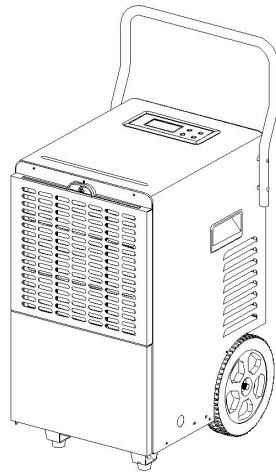

BGD2304-50-X

Thank you for purchasing our product!
To ensure a safe, correct and efficient use of the product,
Please carefully go through and well store this manual.

IMPORTANT SAFEGUARDS

This appliance can be used by children aged from 8 years and above and persons with reduced physical, sensory or mental capabilities or lack of experience and knowledge if they have been given supervision or instruction concerning use of the appliance in a safe way and understand the hazards involved.

Children shall not play with the appliance.

Cleaning and user maintenance shall not be made by children without supervision.

If the supply cord is damaged, it must be replaced by the manufacturer or its service agent or a similarly qualified person in order to avoid a hazard.

This appliance can be used by children aged from 8 years and above and persons with reduced physical, sensory or mental capabilities or lack of experience and knowledge if they have been given supervision or instruction concerning use of the appliance in a safe way and understand the hazards involved. Children shall not play with the appliance. Cleaning and user maintenance shall not be made by children without supervision

If the supply cord is damaged, it must be replaced by the manufacture, its service agent or similarly qualified persons in order to avoid a hazard.

WARNING

- Do not use means to accelerate the defrosting process or to clean, other than those recommended by the manufacturer.
- The appliance shall be stored in a room without continuously operating ignition sources (for example: open flames, an operating gas appliance or an operating electric heater).
- Do not pierce or burn.
- Be aware that refrigerants may not contain an odour.

This appliance is intended to be used by expert or trained users in shops, in light industry and on farms, or for commercial use by lay persons.

Product Structure

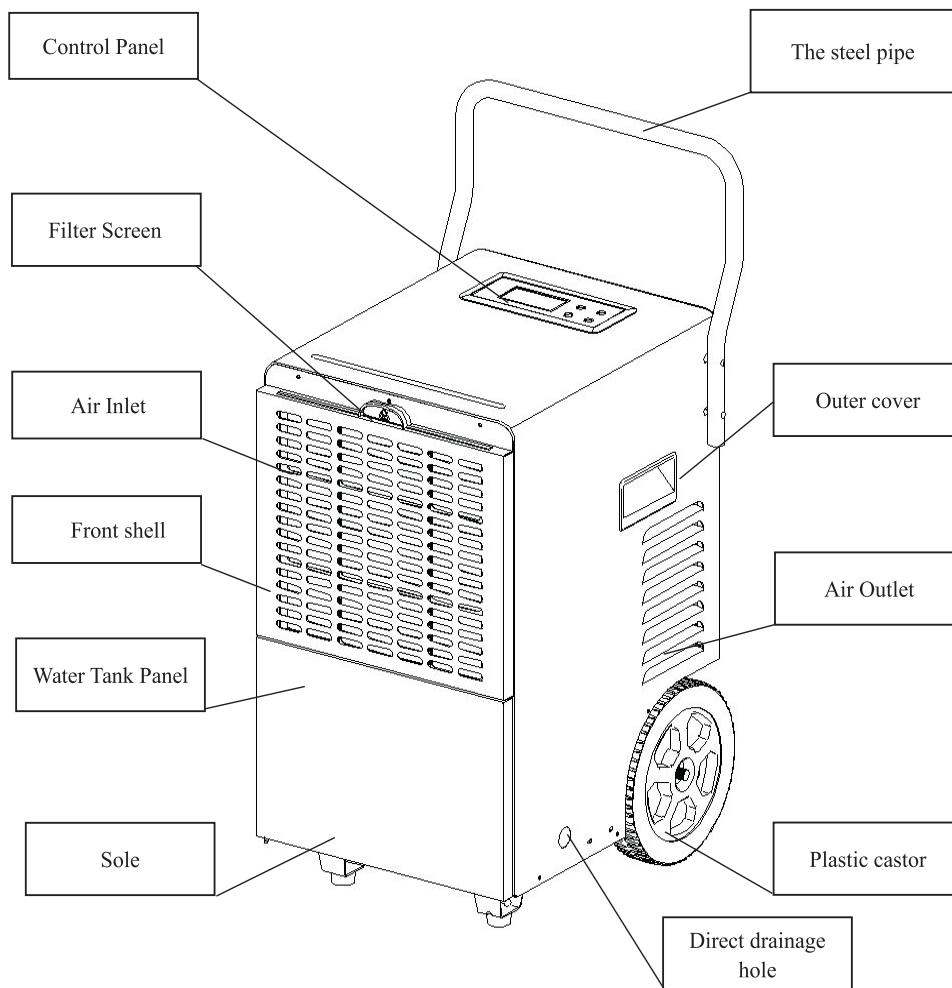

Installation Methods

1. Upper steel pipe installation method: As shown in Fig. 1, screw down the two screws at top of the body, turn the upper steel pipe by 180 degree, and fix the upper steel pipe with the screws in counter-position.

***Tip: Upon end of installation, keep the machine out of any action for 2h before starting to use.**

(Fig.1)

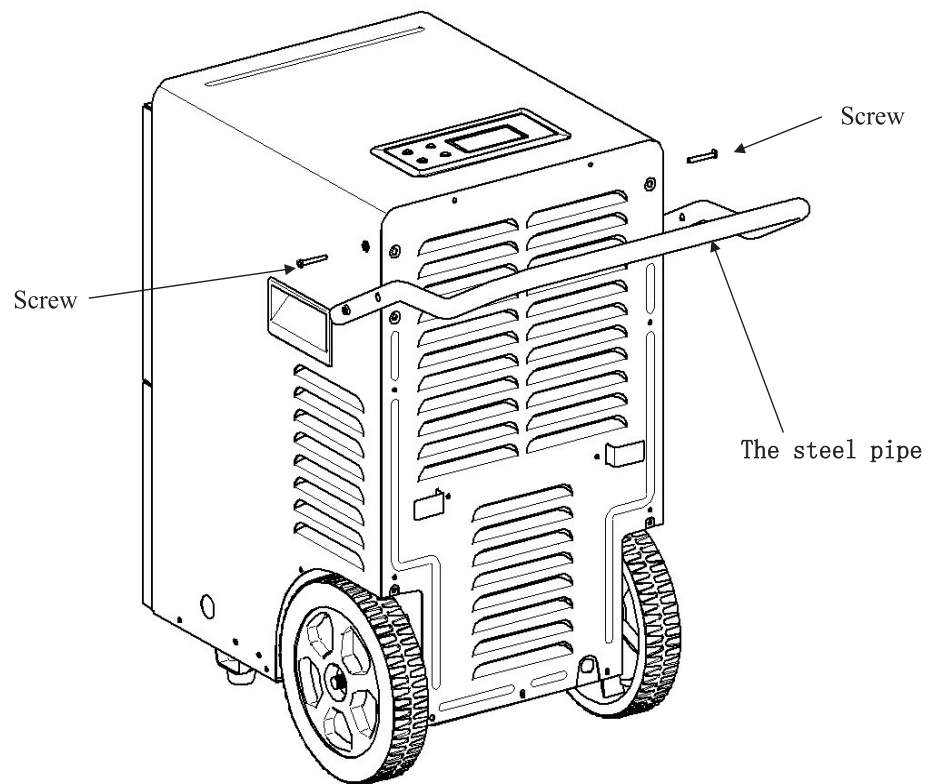

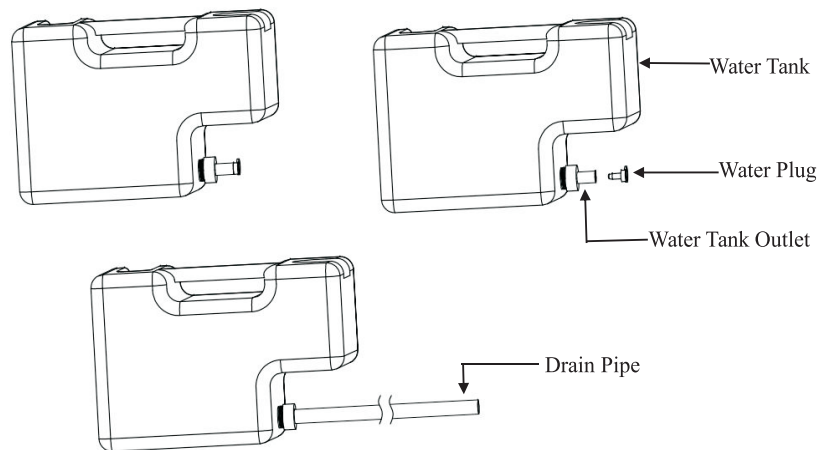

(Fig. 2)

3. Water tank usage: You may use the water tank in two ways. I) Direct use. When the water tank is full, the machine automatically shuts down and enters the standby state, the LED displays the “Full Water” signal and the hummer alarms. When the water tank is emptied and put in place again, the dehumidifier can continue its performance. II) Continuous drainage. As shown in Fig. 2, to restore the performance of the water tank, you need to take out the water tank, remove the drain plug, and install the drain pipe. Put the water tank back to its original position, and the water pipe goes out from the side plate.

***Tip: In continuous drainage, the drainage pipe shall not be set higher than the water tank.**

Warning: If the power cord is damaged, it must be replaced by the professional person from manufacturer, the maintenance department or similar departments.

Product Introduction

Tips: For physiological health of the humanity, protection of furniture and other items indoors and energy saving, the humidity is recommended to range from RH50% to 70%, provided no special requirements are made.

Operation Instructions for Control Panel

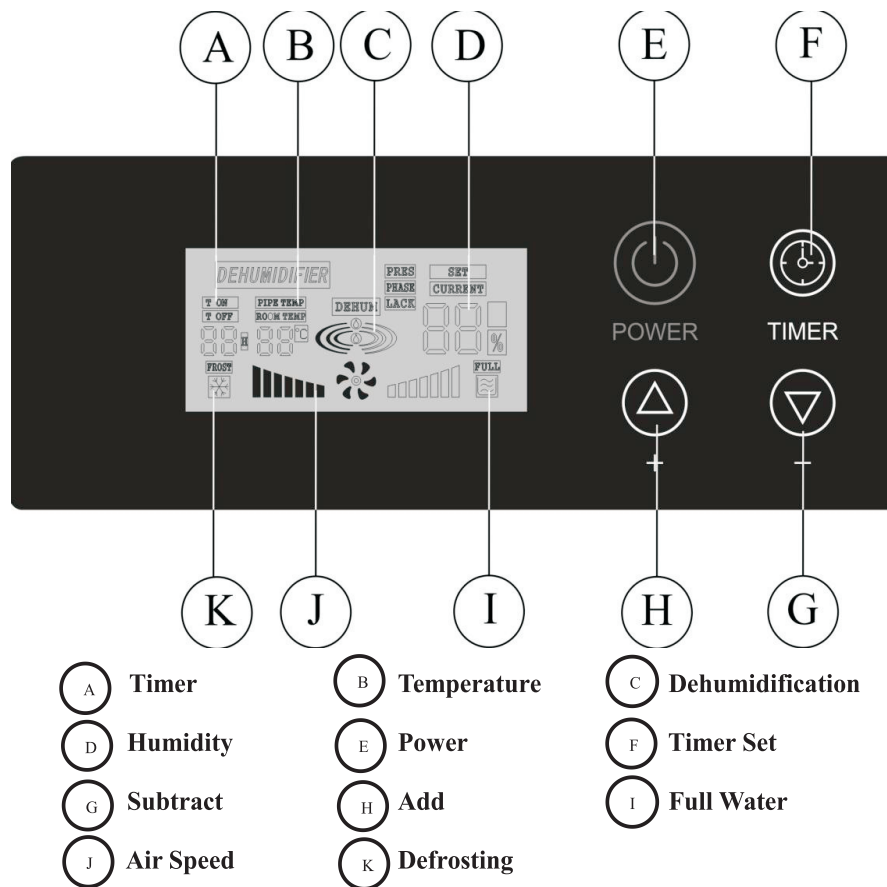

Button	Operation Instructions
ON/OFF	Shift between Switch on and Switch off once for each pressing
+	Adjust different setting values at different states 1、 Increase the humidity value set(RH10% to 95%) 2、 Increase the Timer(hour) set(00 to 24)
-	Adjust different setting values at different states 1、 Decrease the humidity value set(RH10% to 95%) 2、 Decrease the Timer(hour) set(00 to 24)
Timer	Short press the button to launch a cycle of Set on/off Timer and Exit

Function Description

1. Humidity Control

When room humidity value 3% lower than set, compressor shut down, fan delay 3 minutes and shut down; and when it's 3% higher than the humidity value set, both fan and compressor operate.

Note

- ◆ When the humidity is set at the minimum value, it's defaulted to enter the continuous dehumidifying mode
- ◆ Upon fault of the humidity sensor, it turns to the continuous dehumidifying mode
- ◆ Upon fault of the coil sensor, it turns to the Timer defrosting mode(See the defrosting mode)
- ◆ When it's shut down, the fan will be closed 10s later.

2. Protection Function

- ◆ Once shut down, the compressor takes 3min to start. Quick start is available for the first power-on.
- ◆ Power off memory: For abrupt power outage or accidental unplugging of the plug, the system will automatically archive the operating state right before the incident, and continue at that state for the next power-on.
- ◆ Full water protection: When the water tank is full, the dehumidifier automatically shuts down and enters the standby state, the indicator light "Full Water" on and buzzer alarms.

3. Defrosting Mode

Defrosting mode	Description	
Automatic Defrosting	Sensor at normal state	Starting conditions(satisfied at the same time) 1、 It enters this mode when compressor runs constantly for 20min and coil temperature is tested to be $\leq -1^{\circ}\text{C}$ In defrosting, the compressor stops running, fan continues running and the defrosting light is on
Timing Defrosting	In this mode, it defrosts for 3 min and withdraws upon expiration	
The defrosting end condition satisfies one of the conditions	When it is greater than 7°C , Defrost for more than 8 minutes, Or less than or equal to 7°C , Defrost for more than 10 minutes	
Finish defrosting procedure	The compressor and the fan continue to work	
Defrosting faults	Coil sensor faults	the compressor runs constantly 30 minutes, it defrosts 10 minutes;

4. Timer On/Off Function

When it's powered on, you can set timer for powering off; and when it's powered off, you can set timer for powering on. Setting timer for both powering on and off then initiates the cycle timer mode.

A. Set timer for powering on: When it's powered off, press the "Timer" Button. As the "Timer On" icon flickers and the time set flickers in relevant area, press "+" or "-" to adjust the Timer. The hummer makes a sound once the button is pressed. When the time set increases or decreases by "1", holding the button constantly for 2s can continually increase or decrease the time. For non-action for 10s when it's adjusted to the required value, the dehumidifier accepts the new setting and the "Timer On" icon flickers(Ranging from 0 to 24H, and 0H as default);

B. Set timer for powering off: When it's powered on, press the "Timer" Button. As the "Timer Off" icon flickers and the time set flickers in relevant area, press "+" or "-" to adjust the Timer. The hummer makes a sound once the button is pressed. When the time set increases or decreases by "1",

holding the button constantly for 2s can continually increase or decrease the time. For non-action for 10s when it's adjusted to the required value, the dehumidifier accepts the new setting and the "Timer Off" icon flickers(Ranging from 0 to 24H, and 0H as default);

Precautions for Use

Do not repair and disconnect this appliance by yourself.

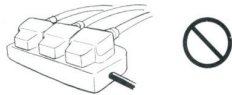

Do not place this appliance beside of a heat source such as stove.



Do not use this appliance in the place where it is expose to sunlight directly.



Turn off this appliance and cut off the power before cleaning.

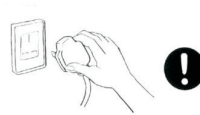

Do not use this appliance in the place where it is close to chemicals.



The suitable place.

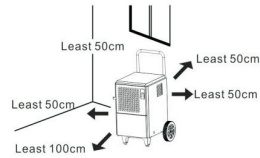

Turn off this appliance and cut off the power,if any accident happens.



Kids and incapacitated people without guardians' monitor and teaching should keep away from this unit.



This unit use special electrical connection and outlet, don't use other extension wire or portable outlet.



Do not use this appliance in the place which may have water.



Troubleshooting

1. Upon fault of the dehumidifier, please cut off the power supply immediately, unplug the plug and check the following items:

Faults	Cause Analysis		Eliminating Methods
Failure to operate	Shown as no power	Power outage or unavailable socket	Check if the power supply works well
		If the plug is well plugged	Plug the power supply in the socket
		Fuse of electric board is blown out	Replace the fuse
		Transformer of electric board is broken	Replace the transformer
	Shown as power on	Environmental humidity lower than the set value	Set again according to the demand
		If the water tank is well placed	Place the water tank in right position
If the entire machine is defrosting		Wait for completion of defrosting	
Unfavorable dehumidifying effect	If there's obstacle at the air inlet/outlet		Remove the obstacle
	If the door and window are open		Close the door and window
	If the indoor temperature is too low		Don't run the dehumidifier
Heavy noise	If the ground is firm and flat		Resettle the dehumidifier
	Dehumidifier laid unsteadily		Steadily resettle the dehumidifier
Water leakage	Inclination		Adjust the dehumidifier to the flat position
	Drain pipe/outlet obstructed		Dismantle the front plate to eliminate impurities
E1	Fault of the coiler		Turn to Timer for defrosting, and cancel system fault function. It can be restored.
E2/E3	Fault of humidity & temperature sensor		Replace the humidity & temperature sensor
EE	Refrigerant leakage		Start the machine after a certain while of time. Ask for help from professionals if the "EE" signal remains
HI	Ambient temperature detected by ambient temperature probe > 38°C		The ambient temperature range of the machine is 5-35°C. Reduce the ambient temperature.
LO	Ambient temperature detected by ambient temperature probe < 3°C		The ambient temperature range of the machine is 5-35°C. Increase the ambient temperature.

2. If the said methods still fail to eliminate the troubles, please directly contact the manufacturer or agents. Don't disassemble the dehumidifier on your own.

3. It's normal to hear the sound of the circulation of refrigerant when the dehumidifier runs.

4. It's normal for the air outlet to reject heat.

Special Tips

Special tips for the user:

1. As a precision part, the humidity sensor may be out of service when used in environment filled with strong corrosive gas and heavy dust.
2. As the dehumidifier is non-resistant against explosion, it's forbidden to be used in environment of special requirements such as that filled with combustible/explosive gas, dust, chemicals or biological products.
3. Damage caused to the dehumidifier by use in said environment is out of the warranty.
4. Grounding measures shall be put in place during installation of the dehumidifier to ensure the safety in use.
5. As water may be discharged from the machine after a certain while of use, attention shall be paid to the dewatering measures.
6. To minimize faults and maximize the lifetime, press the button in a gentle manner.
7. The deviation between the humidity shown on the sensor and the actual humidity is normal, due to impact by the location, environment and temperature.
8. Since the cooled air is dried by the condenser before being discharged during operation of the dehumidifier, it's normal for the air discharged to be hotter than the environment.
9. Since the dehumidifying effect is associated with the temperature and humidity of the environment, the higher the temperature and humidity of the environment, normally the greater the dehumidifying effect; while the lower the temperature and humidity of the environment, typically the lower the dehumidifying effect.

Specification Introduction

Specification Table

Model	BGD2304-50-X
Power Supply	AC 220-240V/50Hz
Max. Removal Capacity	50L/D(30℃ RH80%)
	30L/D(27℃ RH60%)
Rated Power	900W(30℃ RH80%)
	750W(27℃ RH60%)
Rated Current	4.0A (30℃ RH80%)
	3.4A(27℃ RH60%)
Max Suction Pressure	1.0Mpa
Max Discharge Pressure	2.5Mpa
Refrigerant	R290/200g
N. W.	25KG
Product Size	438*376*795mm
Working Temperature	5℃~35℃

Executive standard

EN62233:2008
EN60335-2-40:2003+A11
EN60335-1:2002



Correct Disposal of this product

This marking indicates that this product should not be disposed with other household wastes throughout the EU. To prevent possible harm to the environment or human health from uncontrolled waste disposal, recycle it responsibly to promote the sustainable reuse of material resources. To return your used device, please use the return and collection systems or contact the retailer where the product was purchased. They can take this product for environmental safe recycling.

Warranty Information

The manufacturer provides warranty in accordance with the legislation of the customer's own country of residence, with a minimum of 1 year (Germany: 2 years), starting from the date on which the appliance is sold to the end user.

The warranty only covers defects in material or workmanship.

The repairs under warranty may only be carried out by an authorized service centre. When making a claim under the warranty, the original bill of purchase (with purchase date) must be submitted.

The warranty will not apply in cases of:

- Normal wear and tear
- Incorrect use, e.g. overloading of the appliance, use of non-approved accessories
- Use of force, damage caused by external influences
- Damage caused by non-observance of the user manual, e.g. connection to an unsuitable mains supply or non-compliance with the installation instructions
- Partially or completely dismantled appliances

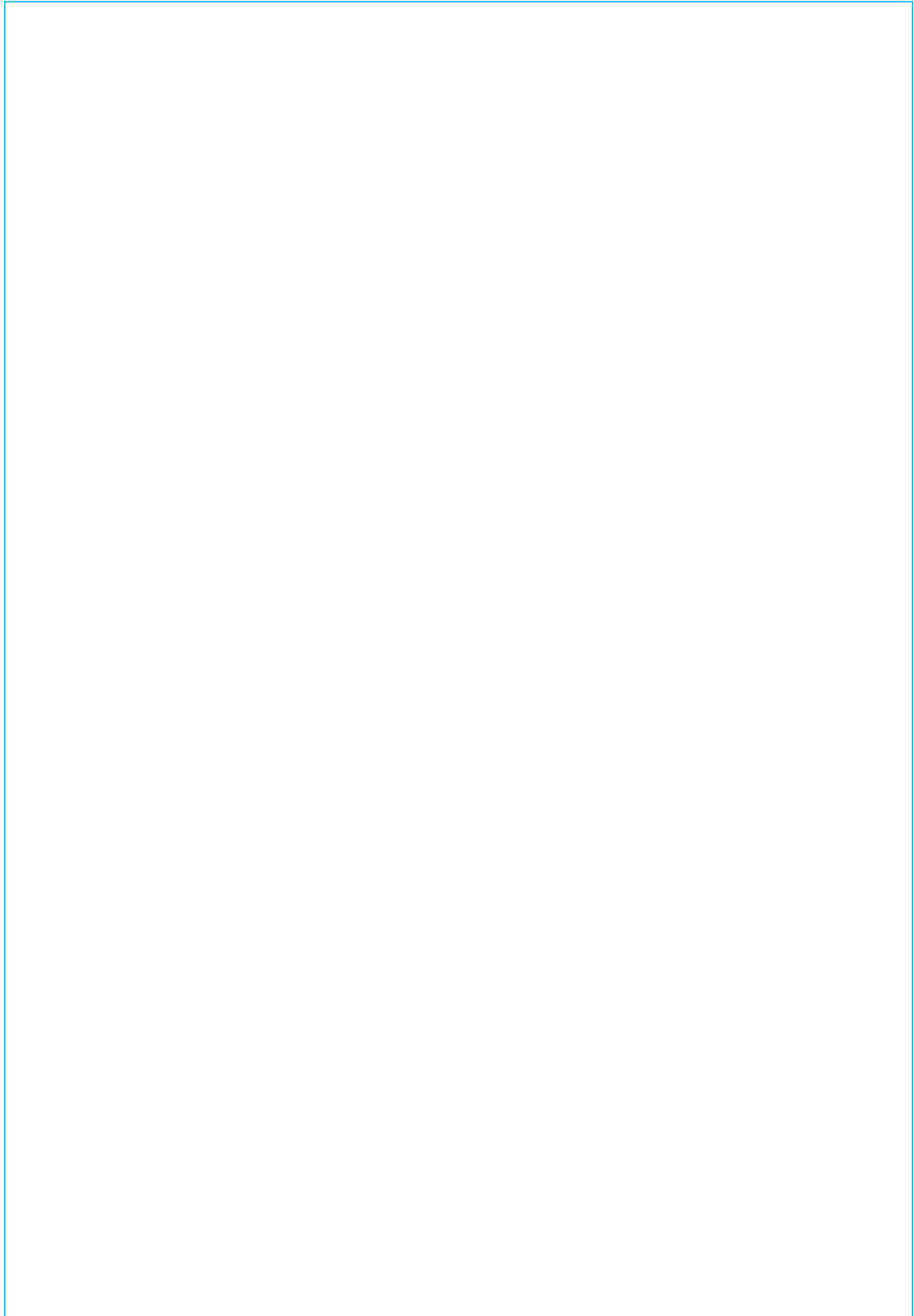

DAHTEC®

Manufacturer :
Ningbo Jingli Trading Co., Ltd.
Room 1421, Building 14-1, Cihui Building
Baisha Road Sub-district
Cixi City, Ningbo
Zhejiang Province, China



YH Consulting Limited
Add:C YH Consulting Limited Office 147,Centurion House
London Road ,Staines-upon-Thames , Surrey, TW18 4AX,London
Tel:+44 07514677868
E-mail:H2YHUK@ gmail.com