

# ASSEMBLY INSTRUCTIONS

DESCRIPTION: KING/ CAL KING BED

Caution: Please read instructions thoroughly before unpacking assembly parts. Sharp, exposed staple tips can cause injury, therefore, for your protection, please remove any exposed staple used in packing.

1. We recommend that you should assemble this product with the assistance of another person; this will make assembly easier, and will help to eliminate damage to the product or injury to persons during assembly.
2. Be sure to check all packing materials carefully for small parts that may have come loose inside the carton during shipment.
3. Please do not over tighten screws or bolts until the assembly is complete
4. Please put all parts on a non-abrasive floor before assembly, and follow the assembly steps to assemble your newly purchased product correctly and efficiently.

PART LISTS			
NO.	Description	Sketch	Q'ty
1	HEADBOARD		1PC
2	FOOTBOARD		1PC
3	SIDE RAILS		2PCS
4	SLAT SUPPORT LEGS WITH LEVELER		8PCS
5	SLATS		4PCS
6	LEG OF HEADBOARD (L&R)		2PCS

HARDWARE LISTS			
NO.	Description	Sketch	Q'ty
A	BOLT Ø5/16*2-1/4 "		6PCS
B	SPRING WASHER Ø5/16*13*1.2		6PCS
C	FLAT WASHER Ø5/16*19*1.8		6PCS
D	BOLT Ø5/16*3"		8PCS
E	"C" WASHER Ø5/16		8PCS
F	SPRING WASHER Ø5/16*13*1.2		8PCS
G	NUT Ø5/16*16MM		8PCS
H	ALLEN KEY		1PC
I	WRENCH 5/16"		1PC
J	SCREW Ø8*1"		8PCS

## STEP 1

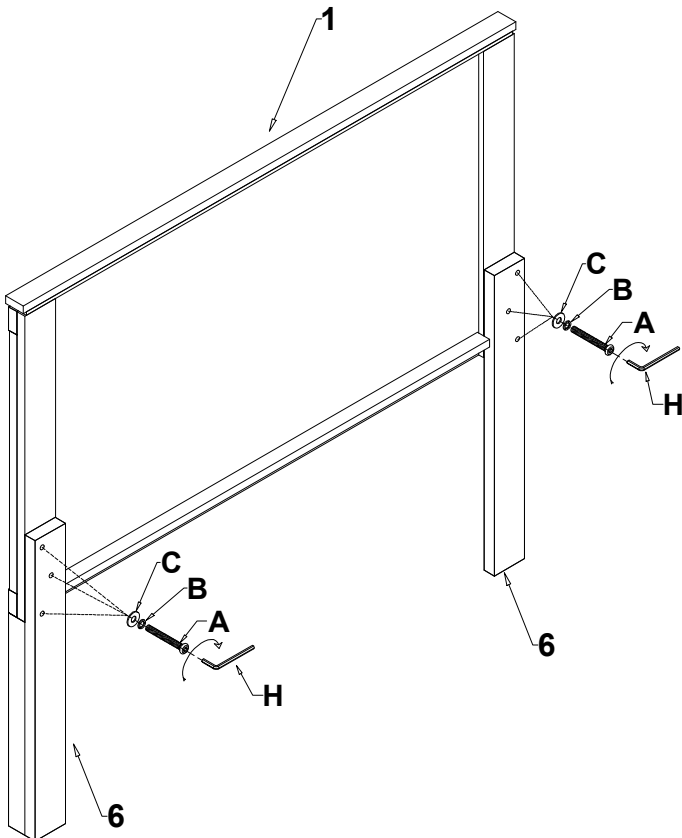

## STEP 2-2

