



OCTAGON CEDAR SANDBOX XL WITH LINER AND COVER

Assembly Instructions. Adult Assembly Required. Read all instructions before use. This manual is part of the product and must be kept for future reference.

MODEL NUMBER(S)*:

99891 - Natural

VERSION CODE*:

1.0/1124/VN

** These numbers are needed if replacement parts are requested*



Find us on  •  YouTube • 

Assembly Videos available on YouTube

FOR REPLACEMENT PARTS:
<http://www.badgerbasket.com/parts>

Badger Basket®, PO Box 227, Edgar, WI 54426-0227 USA • **Web:** www.badgerbasket.com
U.S. Based Customer Service Toll-Free (Mon-Thurs 7:00 AM-4:00 PM CST): 1-800-236-1310
Phone: 715-352-2311 • **Fax:** 715-352-3163



BEFORE YOU BEGIN ASSEMBLY:

Check all parts. If anything is missing or not satisfactory, please **DO NOT** call the store or return the product to them. Please go online to:

<http://www.badgerbasket.com/parts>

Most problems are resolved without you needing to leave home.

When emailing or calling us, please have this instruction manual, your product model number, and your Version Code ready.

Your Model Number is: SEE COVER PAGE

Your Version Code is: 1.0/1124/VN



WARNING

ADULT ASSEMBLY REQUIRED

DUE TO THE PRESENCE OF SMALL PARTS AND SHARP POINTS DURING ASSEMBLY, KEEP OUT OF REACH OF CHILDREN UNTIL ASSEMBLY IS COMPLETE.

> Read all instructions before beginning! <

NOTE:

Sand is not included. You can purchase it separately from most home improvement and hardware stores, or have it delivered from many local garden centers/landscape supply companies. You will need approximately 1200-1500 pounds of sand to fill the sandbox 5-6 inches deep.

If you want the sandbox to be deeper, assemble the sandbox and then mark the ground following the INTERIOR edges of the box. Move the sandbox aside and excavate within the marked area to the depth that you desire. Place the sandbox frame around the excavated area, and fill with the amount of sand desired.

It's helpful to use landscape fabric beneath the sand/sandbox (also found at hardware and home improvement stores), particularly if you excavate a hole to make the sandbox deeper. You can also place garden fabric under the sand to prevent weed growth. We do not recommend using garden plastic so the sand drains properly.



WARNING! FAILURE TO FOLLOW THESE WARNINGS AND THE INSTRUCTIONS MAY RESULT IN SERIOUS INJURY OR DEATH. NEVER LEAVE CHILD UNATTENDED.

- **READ ALL INSTRUCTIONS** before use of this product.
- Keep instructions for future use.
- Use only the parts and hardware provided by Badger Basket.
- Do not use the product if it is damaged, broken, cracked, or missing parts.
- Hardware may include small parts. **Choking Hazard!** Keep unassembled parts out of the reach of small children.
- No product is a replacement for adult supervision.
- **ALWAYS** keep your child in view while in the sandbox.
- Children should always wash their hands thoroughly with soap and water after playing in the sandbox, especially before handling food.
- The weight limit of each seat should not exceed 200 pounds (91 kg)
- This product is heat treated and stained and designed to be outdoors. No further treatment of the wood is required before use. Any additional surface treatment is optional. Consult with your local home improvement store if desired.
- Do not install the sandbox on top of bricks, pavers, or concrete because this can interfere with drainage and damage the product.

A	B	C
SIDE PANEL	SEAT	BRACKET
8 pcs	4 pcs	8 pcs

D	E	F	G
M6*20mm	4*30mm		
BRACKET SCREW	SEAT SCREW	LINER	COVER
32 pcs	48 pcs	1 pcs	1 pcs

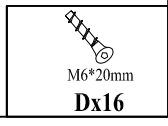
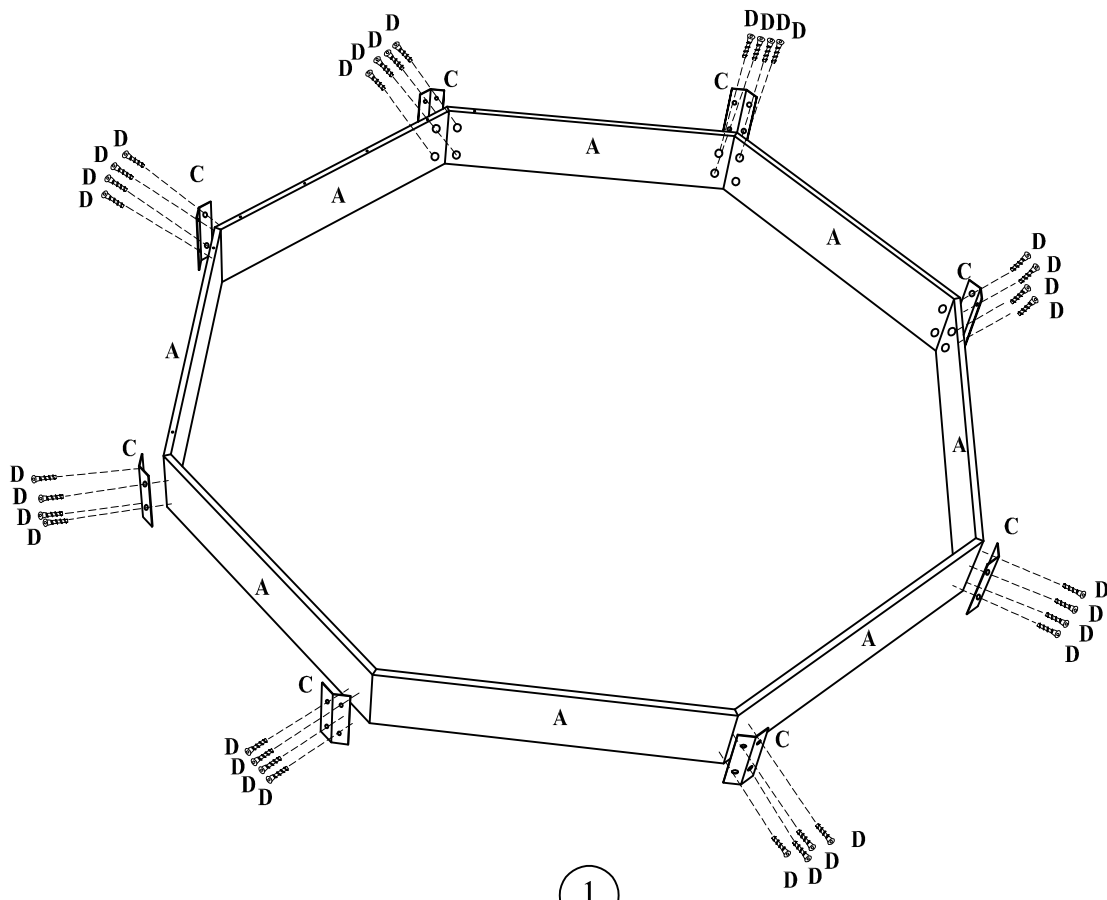

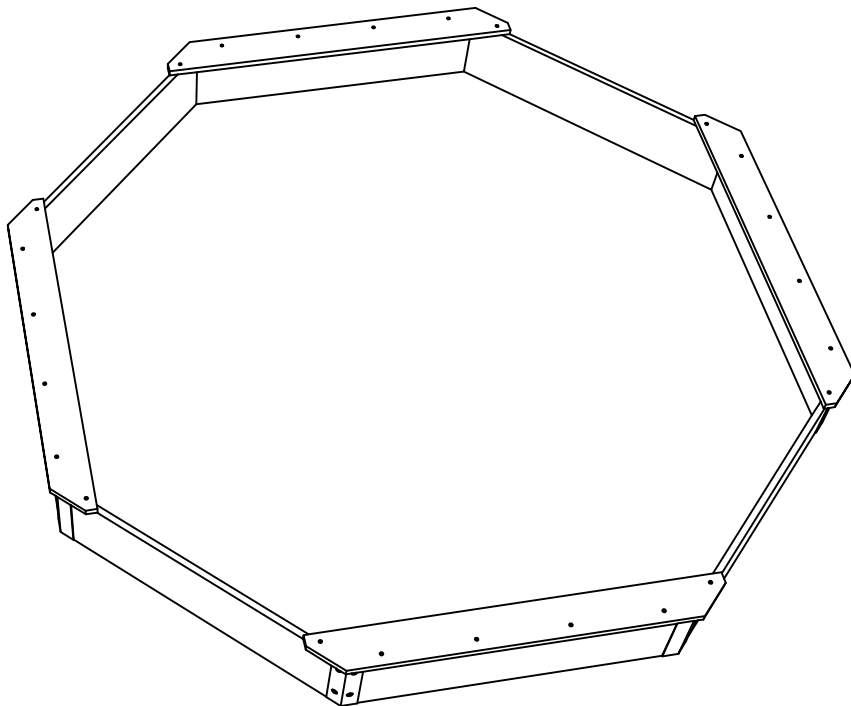
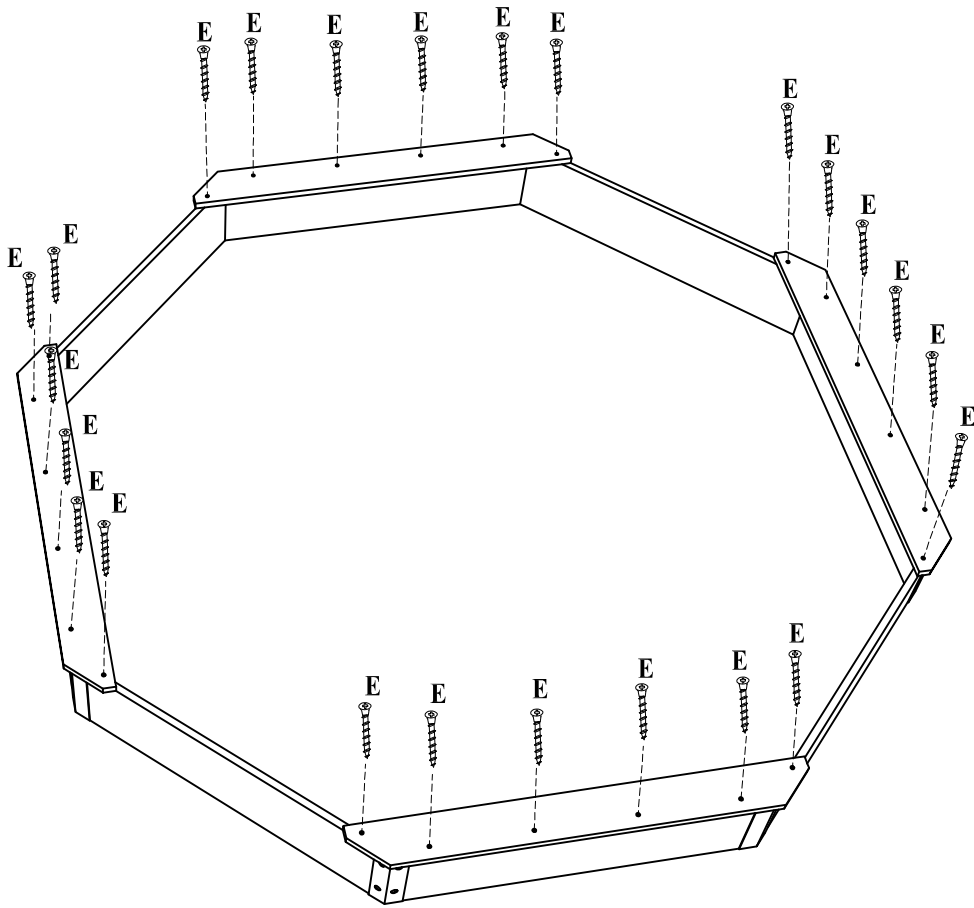

2

4*30mm
Ex48

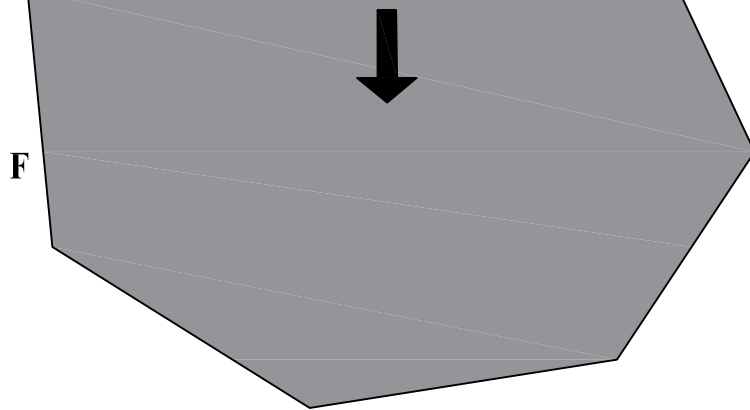
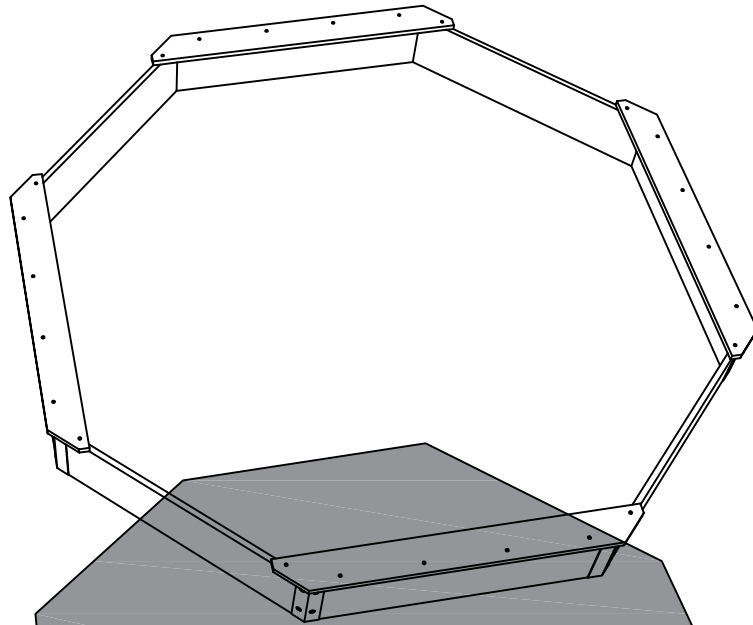
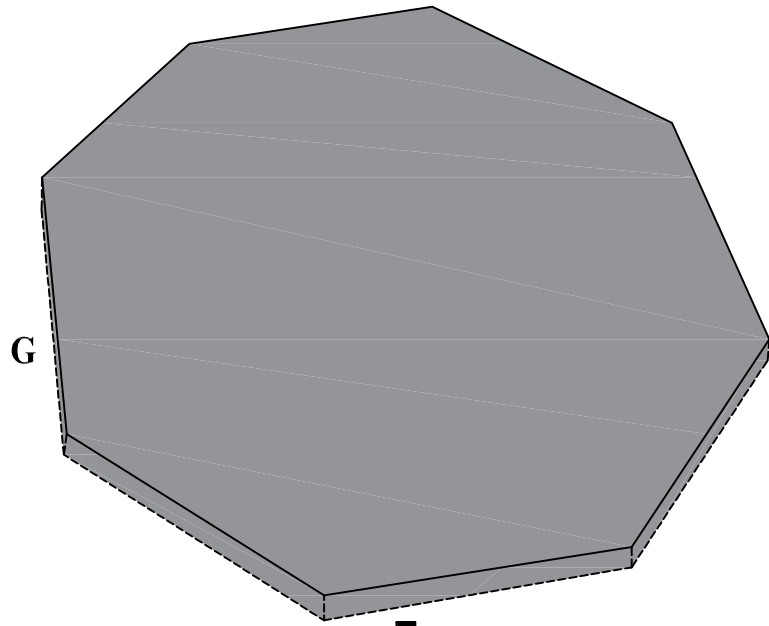

3