

Trouble Shooting

Missing/Damaged pieces/
Wrong size and installation issues



Contact us with your problem, pic,
number and qty to the "Contact seller"
button in the detail page of your order



Respond with 24 hours to solve issue

Before You Start

1. Read through each step carefully and follow the proper order
2. Separate and count all your parts and hardware
3. Give yourself enough room for the assembly process
4. Caution: If using a power drill or power screwdriver for screwing, please be aware to slow down and stop when screw is tight. Failure to do so may result in stripping the screw

Cam Lock Fastening System

This Cam Lock Fastening System will be used throughout the assembly process

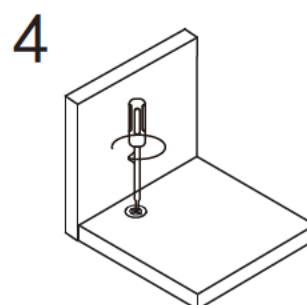
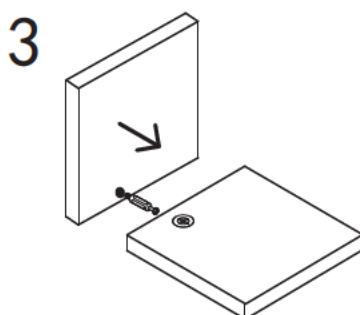
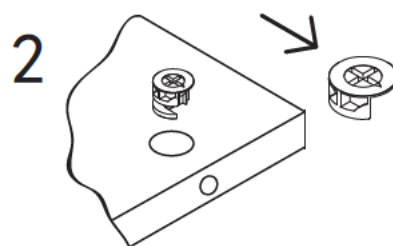
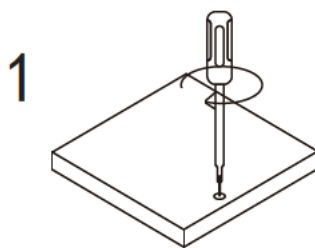

Parts List

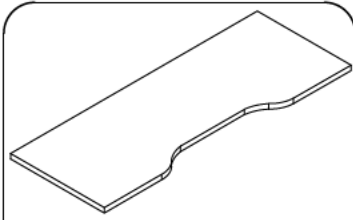

1

1PC

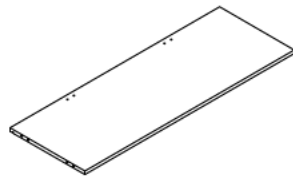

2

1PC

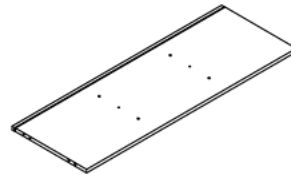

3

1PC

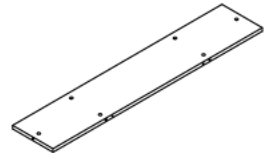

4

1PC

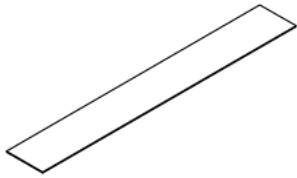

5

1PC

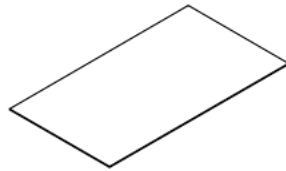

6

3PC

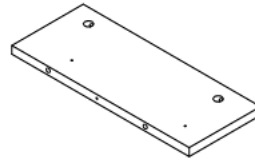

7

2PC

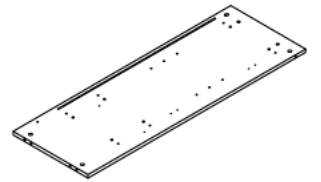

8

1PC

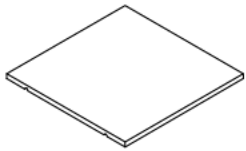

9

2PC

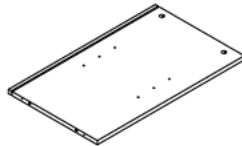

10

1PC

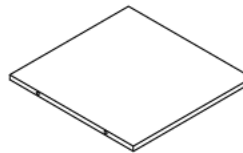

11

1PC

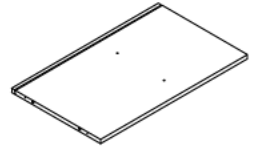

12

1PC

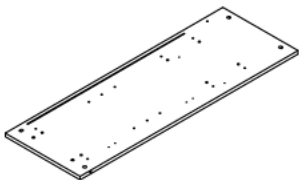

13

1PC

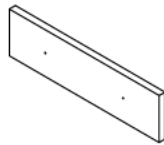

14

2PC

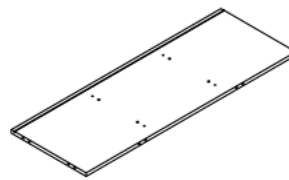

15

1PC

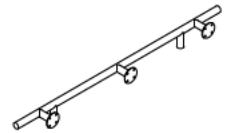

16

1PC

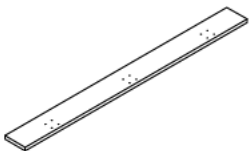

17

1PC

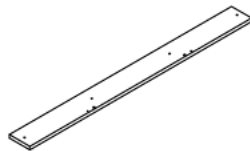

18

1PC

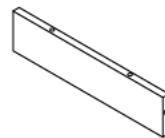

19

2PC

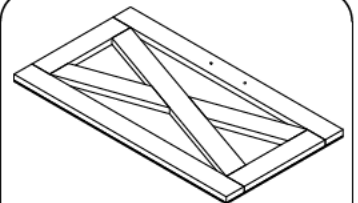

20

2PC

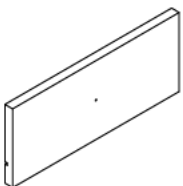

21

3PC

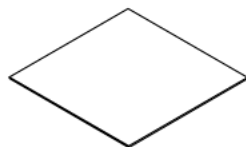

22

3PC

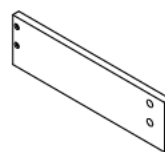

23

3PC

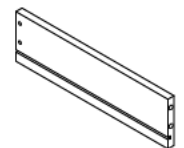

24

3PC

Parts List

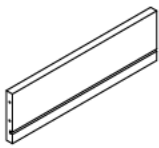

25

1PC

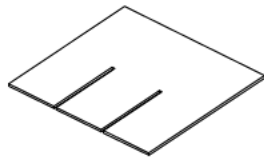

26

1PC

SPECIAL VERSION

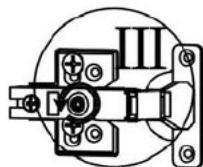
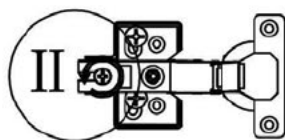
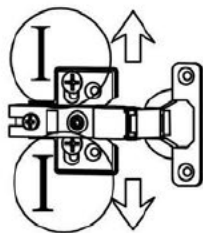

For specific adjustment details, please carefully read the precautions on the last page!

I: Adjust the screws at I to move the hinge up and down to adjust the up and down position of the door panel.

II: Adjust the screws at II to adjust the distance between the door panel and the vertical panel.

III: Adjust the screws at III to adjust the distance between the door panels.

Hardware List



A 60PC

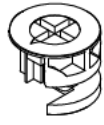

ø15

B 38PC



Ø8*30mm

C 26PC



Ø4*40mm

D 18PC

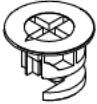

ø12

E 22PC

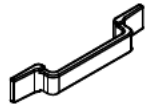

F 2PC



ø3*12mm

G 24PC



Ø4*14MM

H 12PC

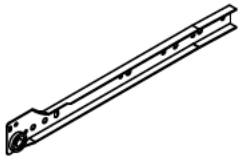

I 3PC

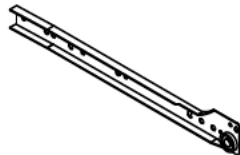

J 3PC

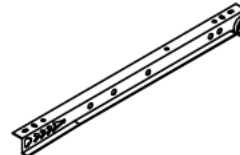

K 3PC

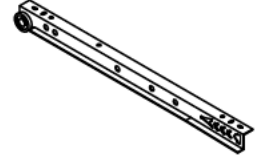

L 3PC



M4*18mm

M 3PC



Ø4*25mm

N 4PC



O 8PC



P 3PC



ø3.5*14mm

Q 16PC



R 4PC



Ø6*30mm

S 4PC



M4*22mm

T 4PC

STEP 1

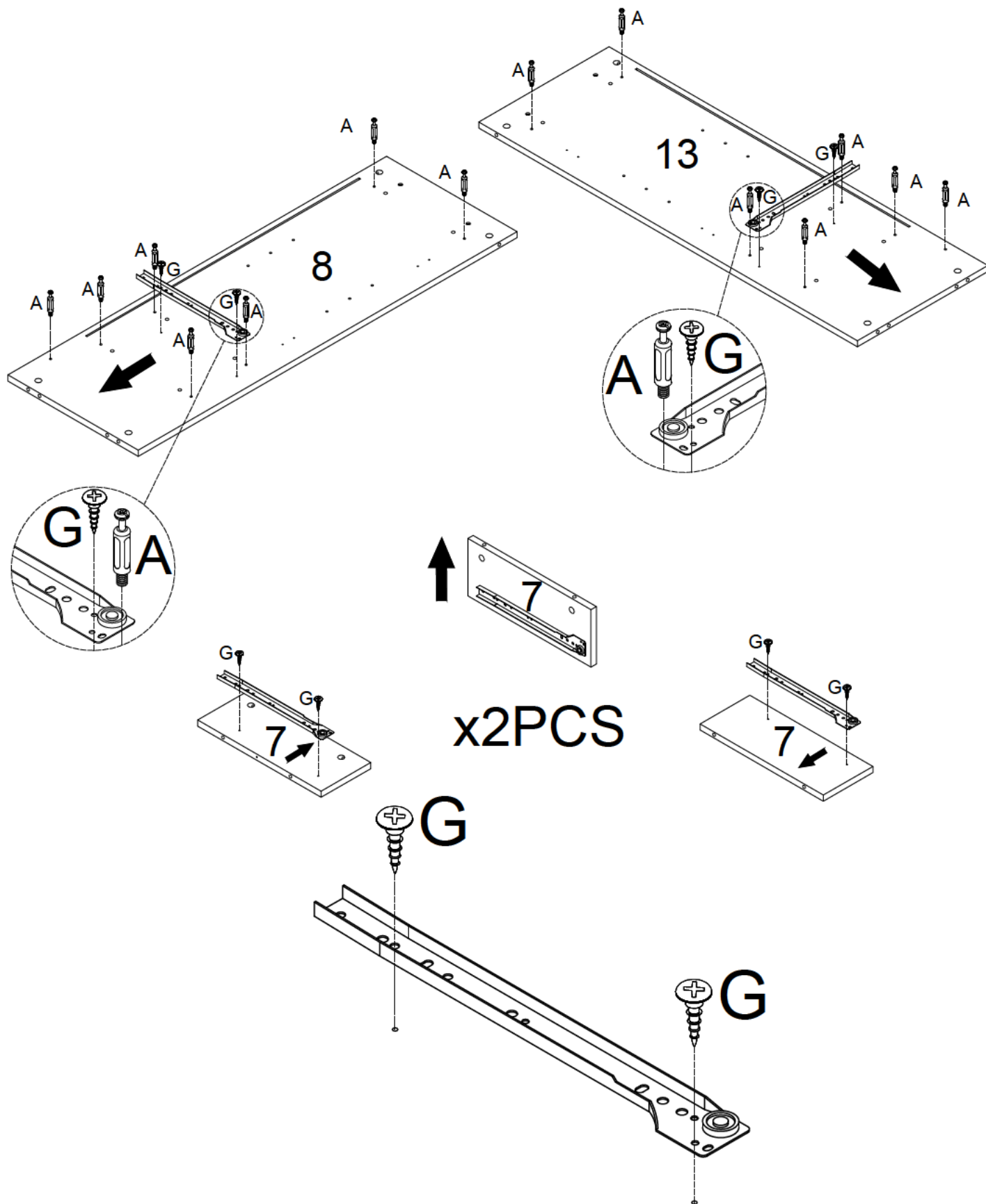
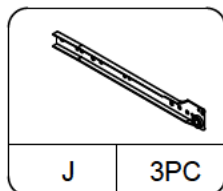
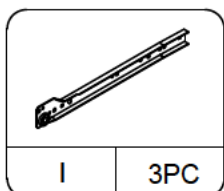
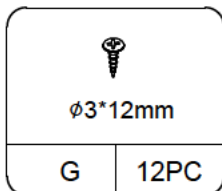
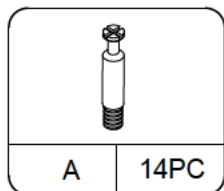

STEP 2

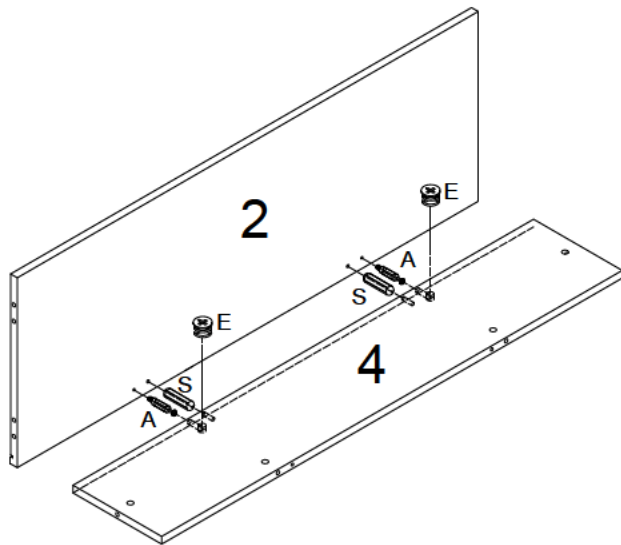
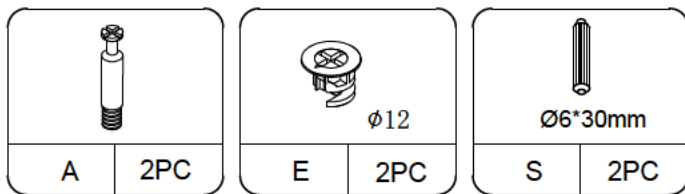

STEP 3

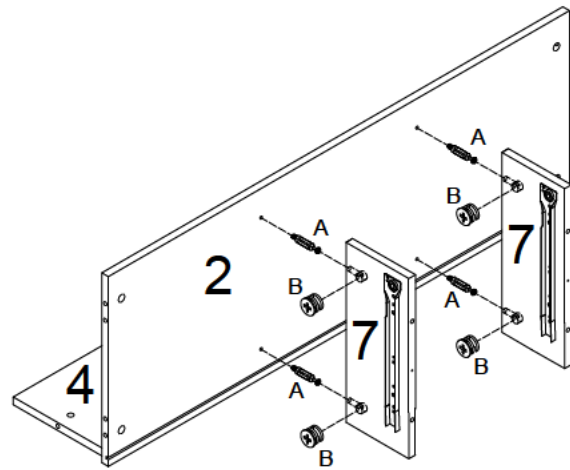
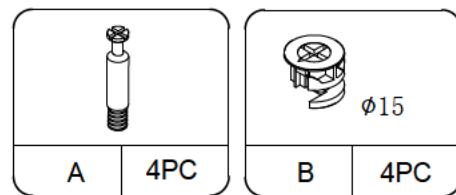

STEP 4

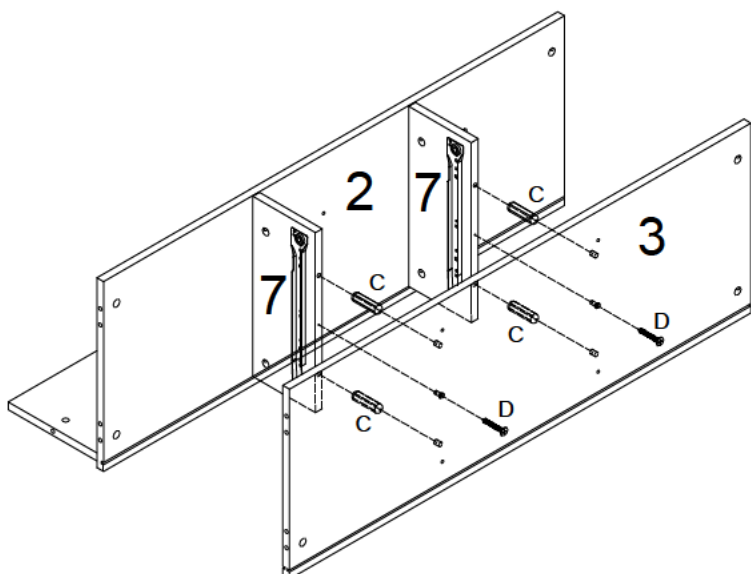
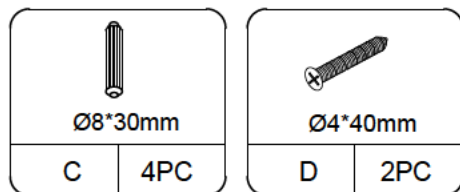

STEP 5

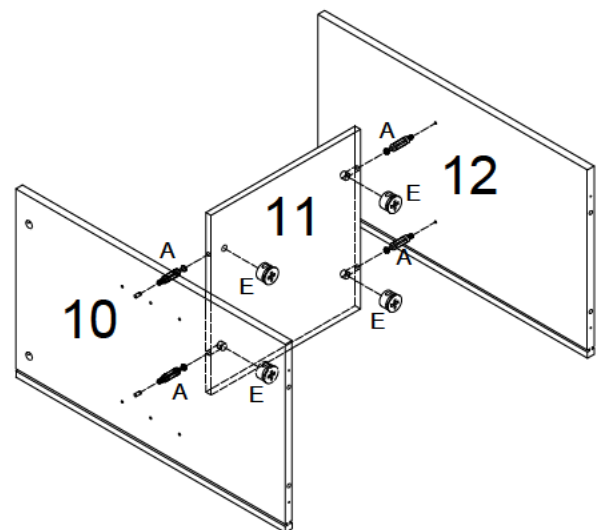
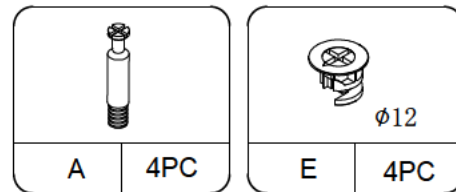

STEP 6

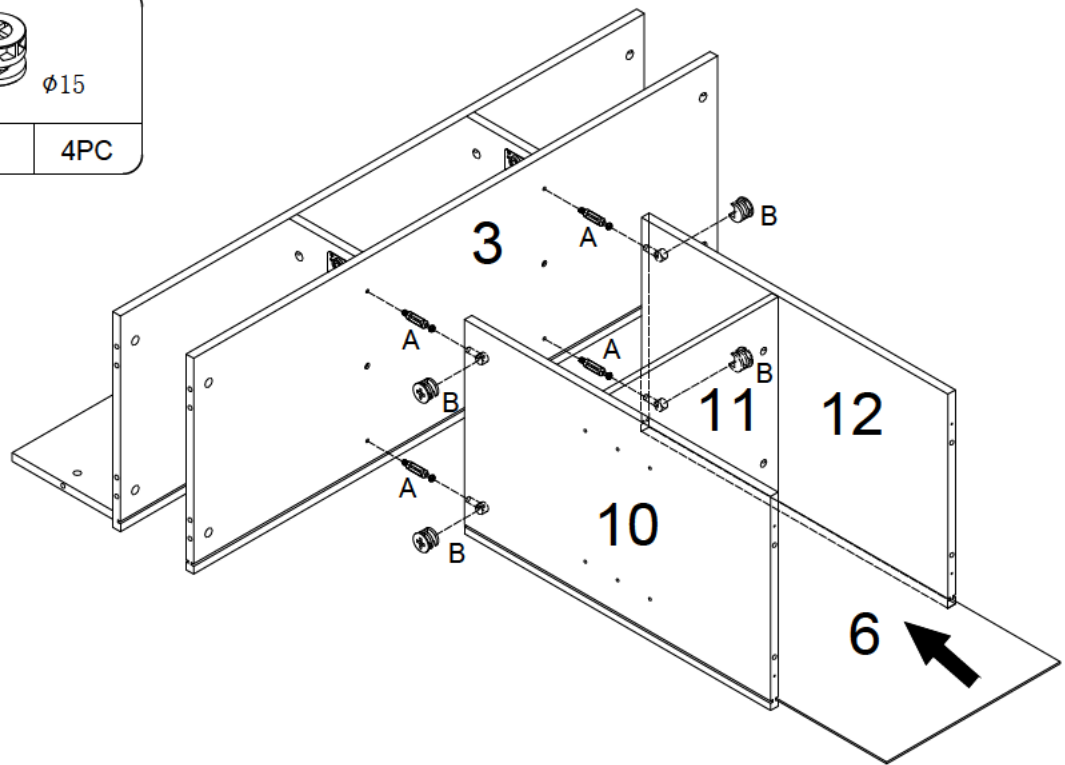
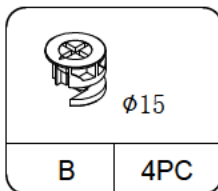
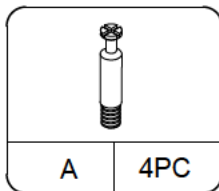

STEP 7

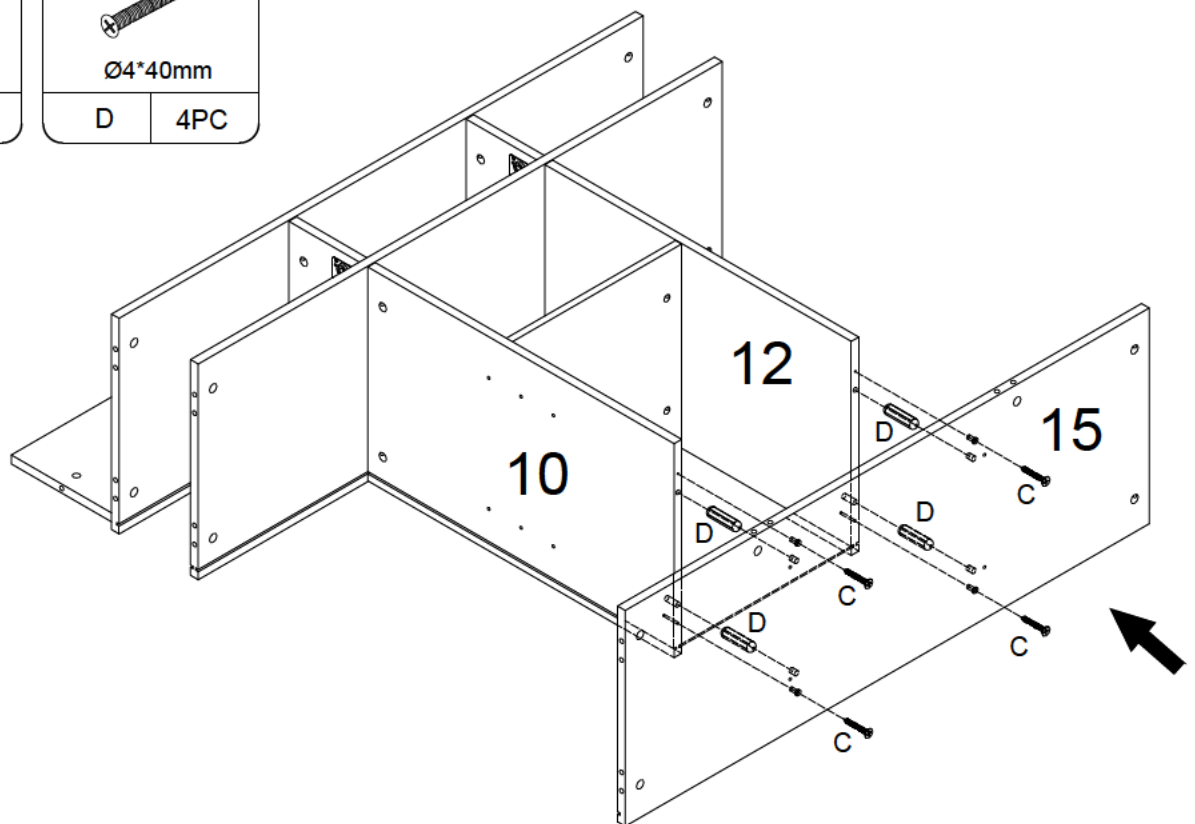
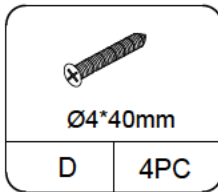
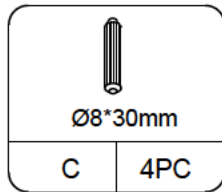

STEP 8

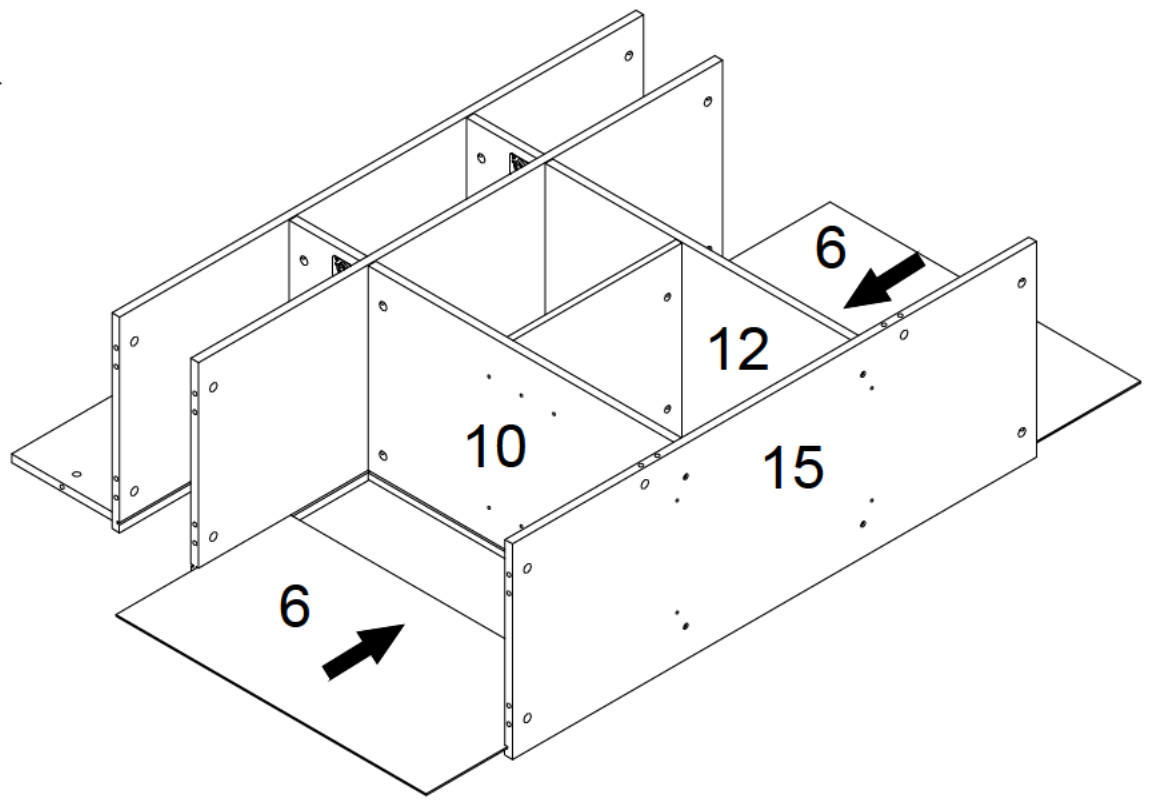

STEP 9

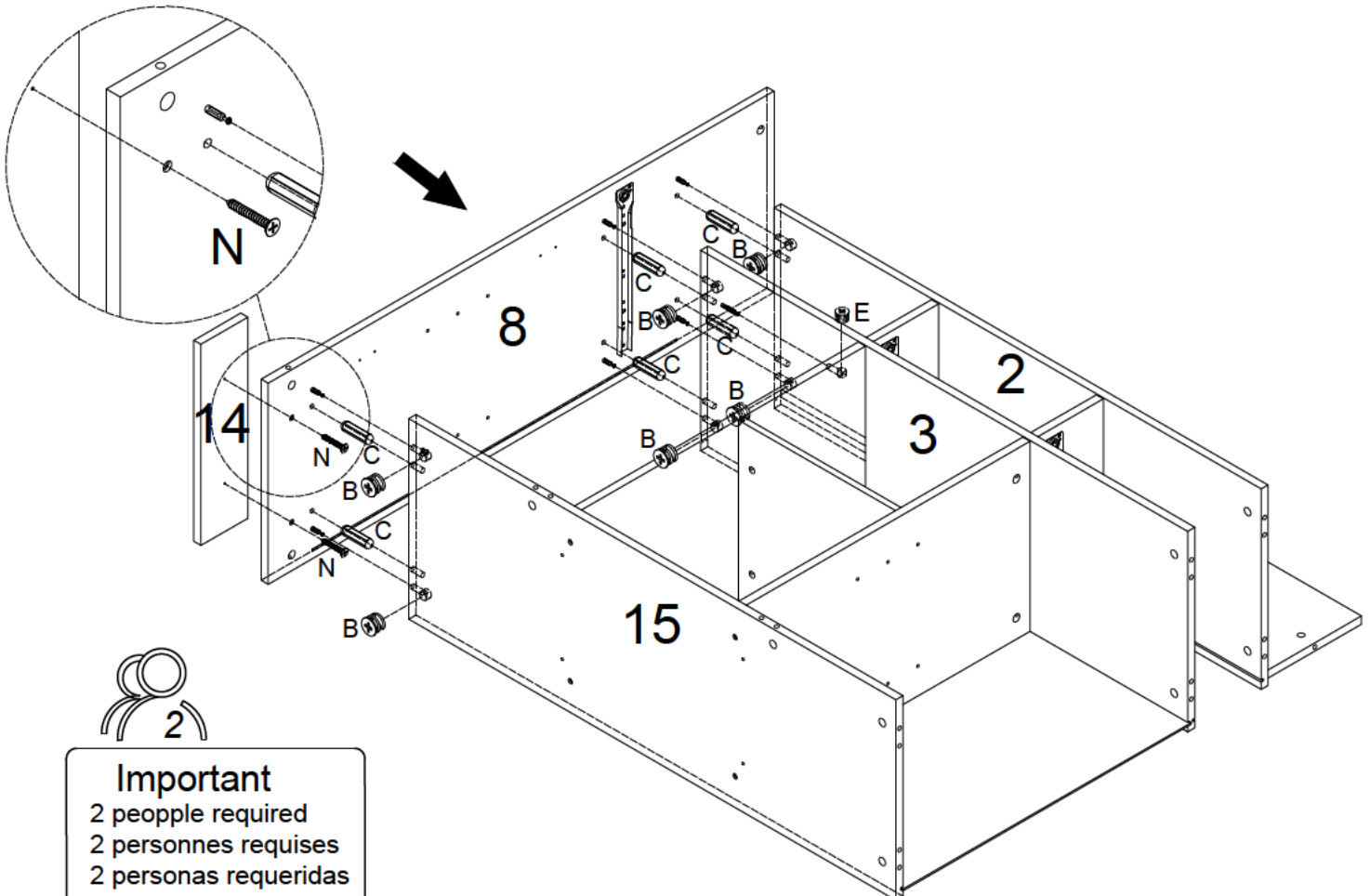
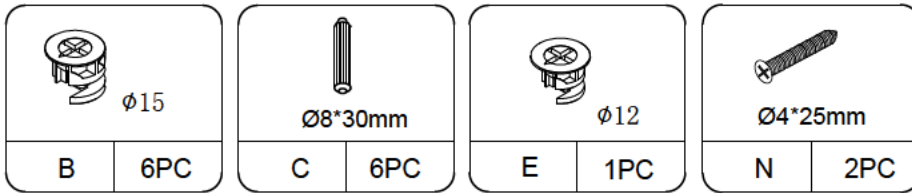

STEP 10

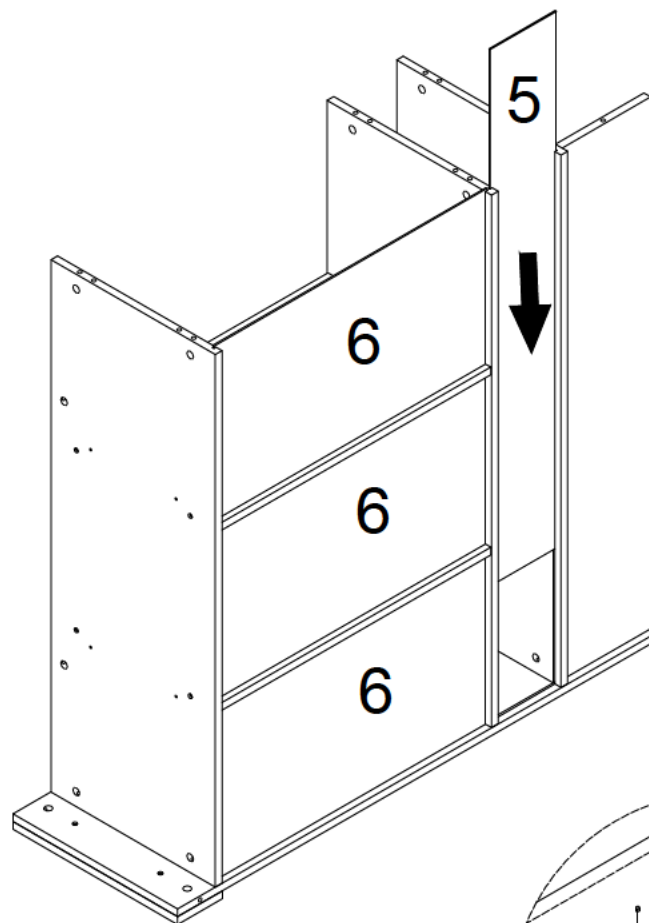

STEP 11

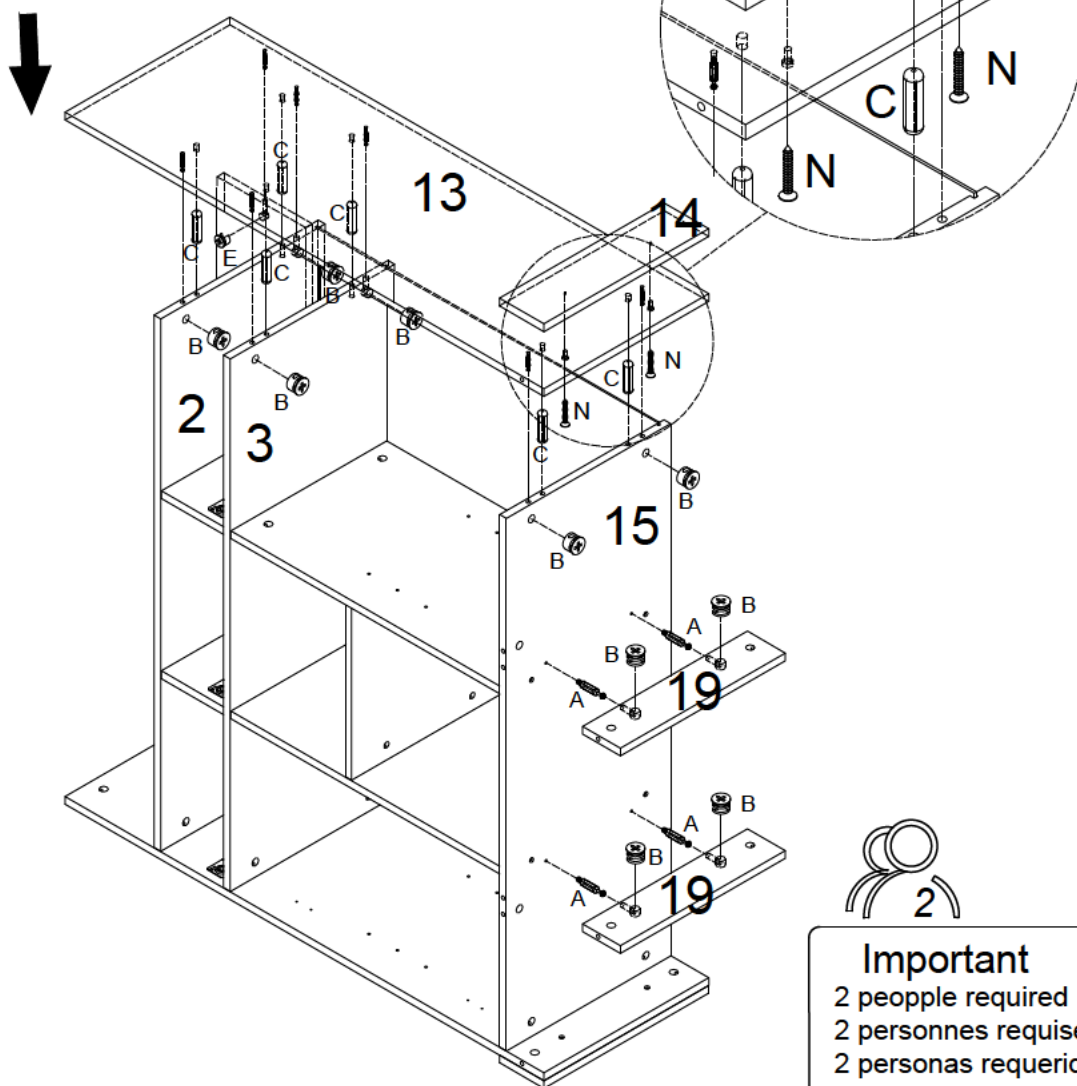
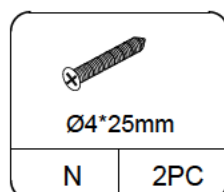
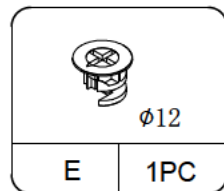
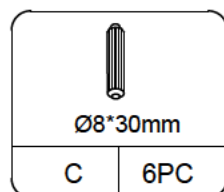
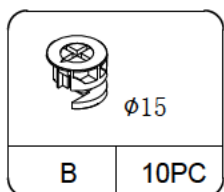
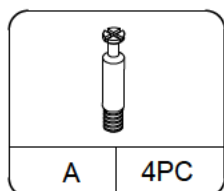

Important
 2 people required
 2 personnes requises
 2 personas requeridas

STEP 12

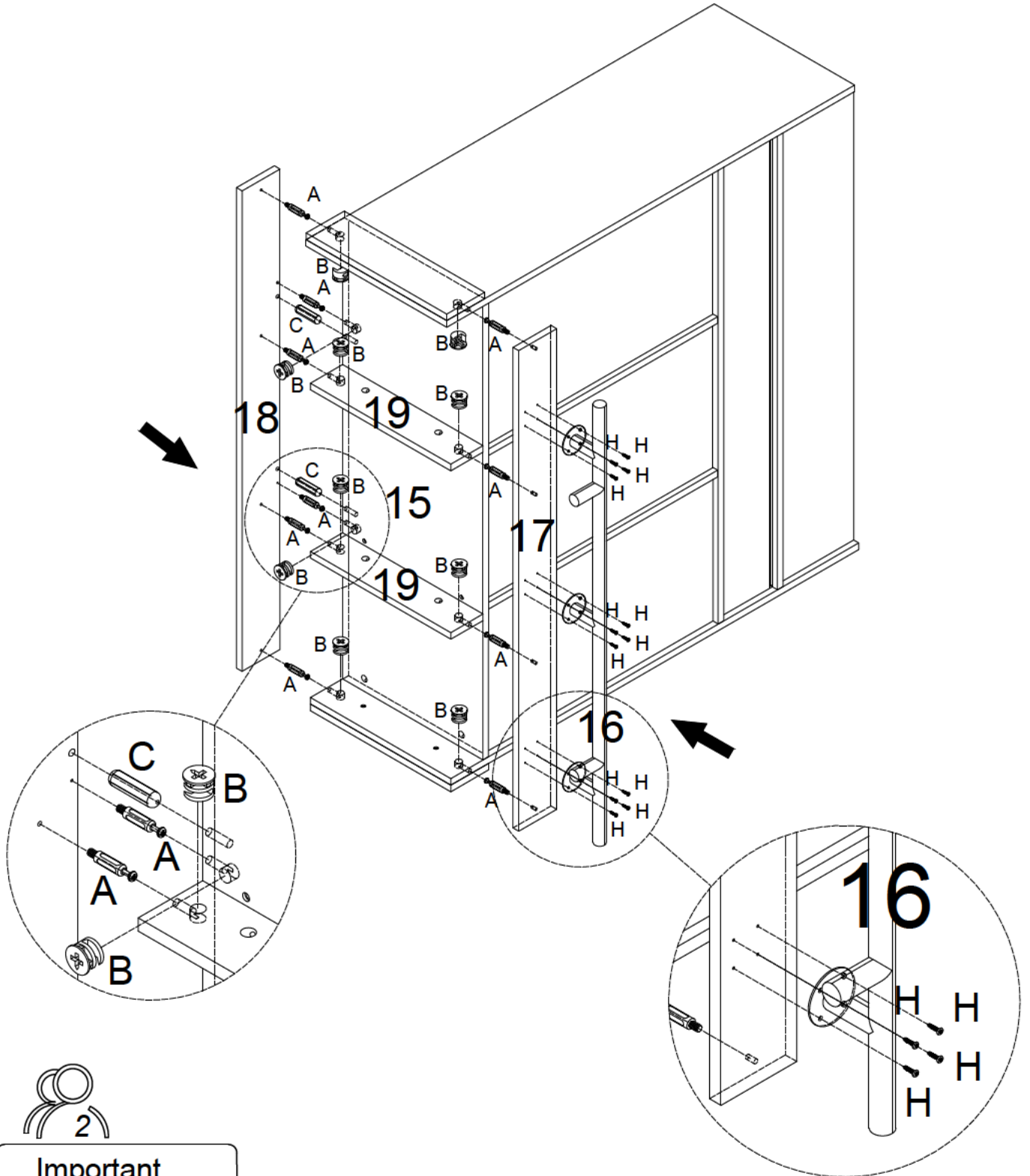
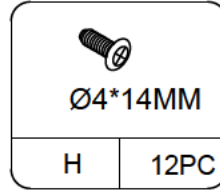
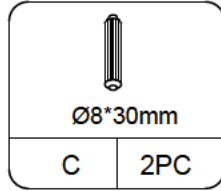
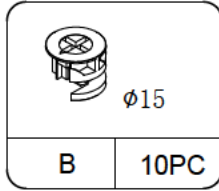
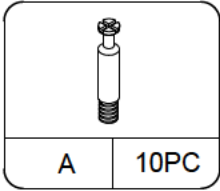

2

Important

2 people required
2 personnes requises
2 personas requeridas

STEP 13

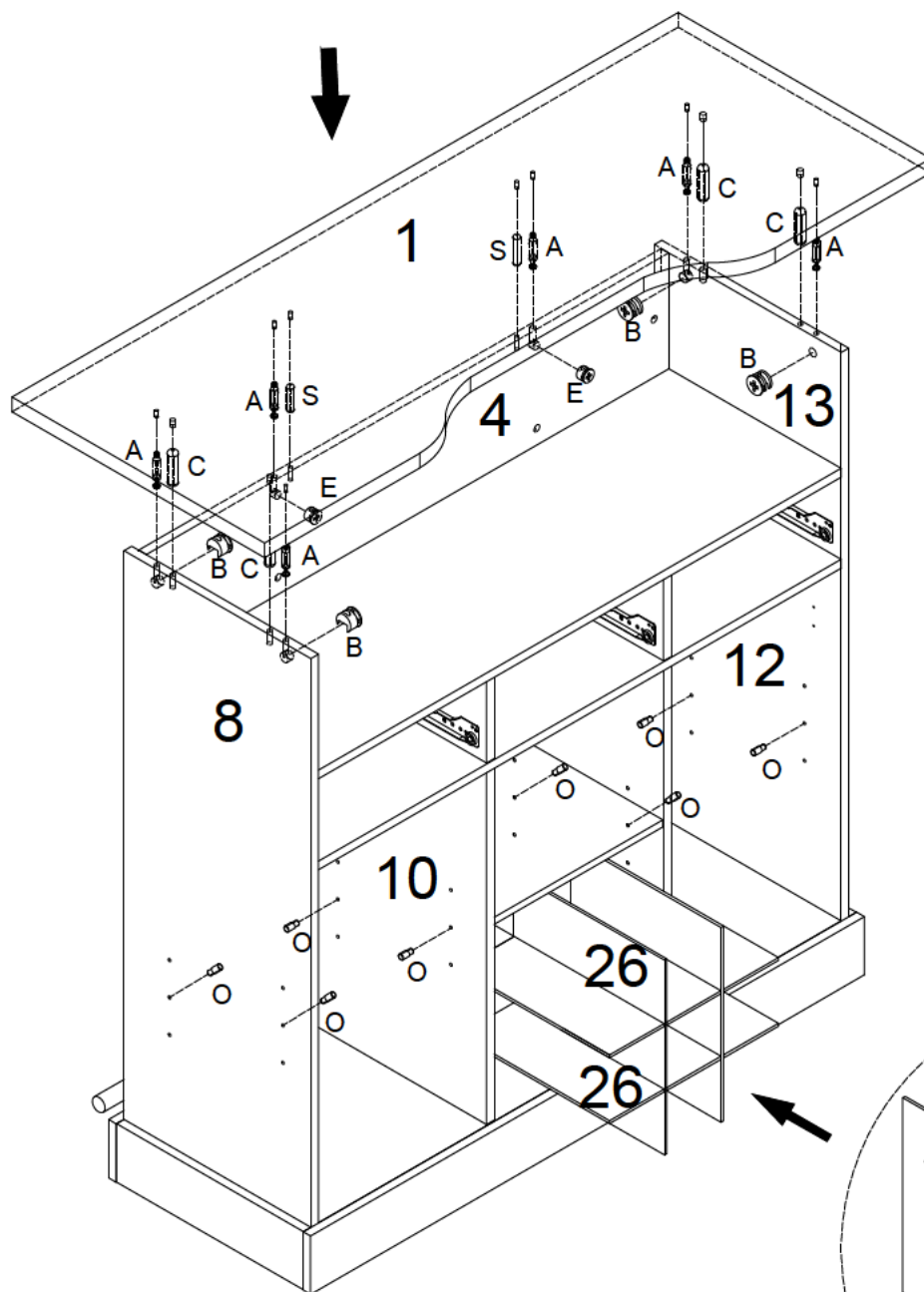
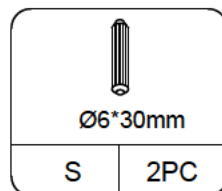
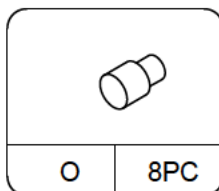
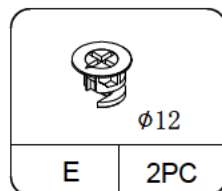
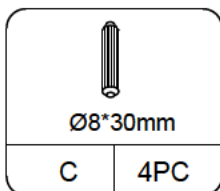
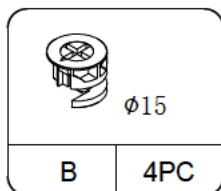
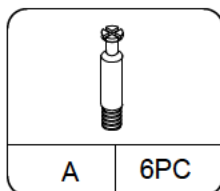

Important

2 people required
2 personnes requises
2 personas requeridas

STEP 14

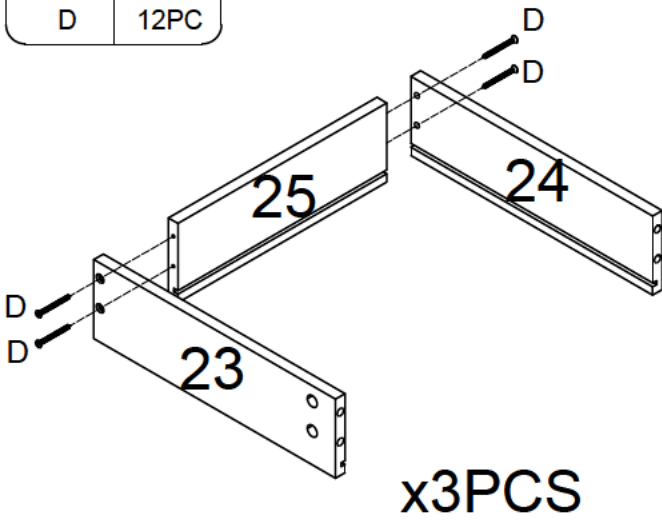
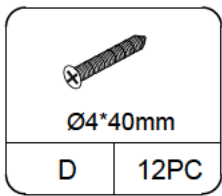

STEP 15

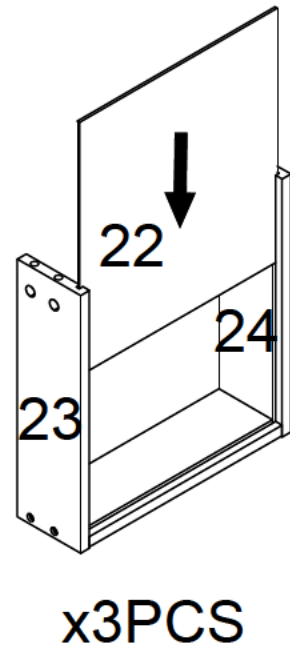

STEP 16

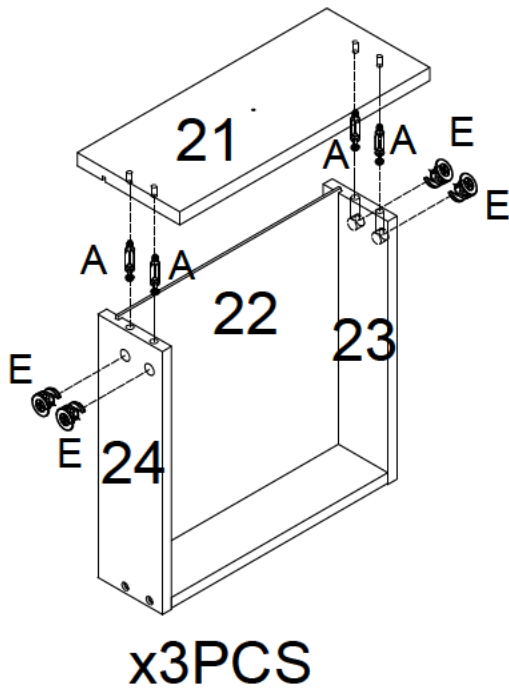
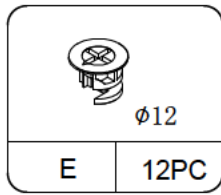
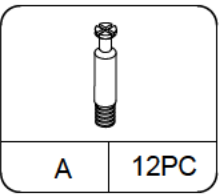

STEP 17

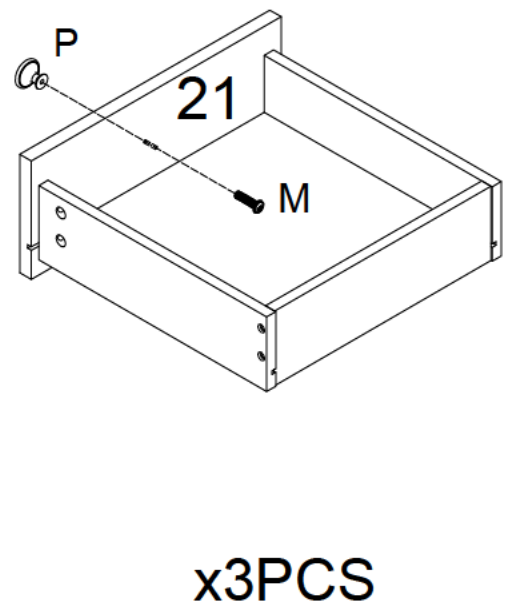
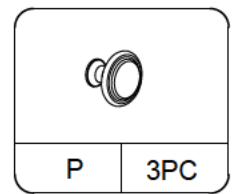
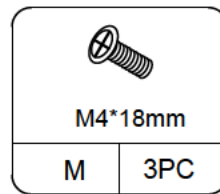

STEP 18

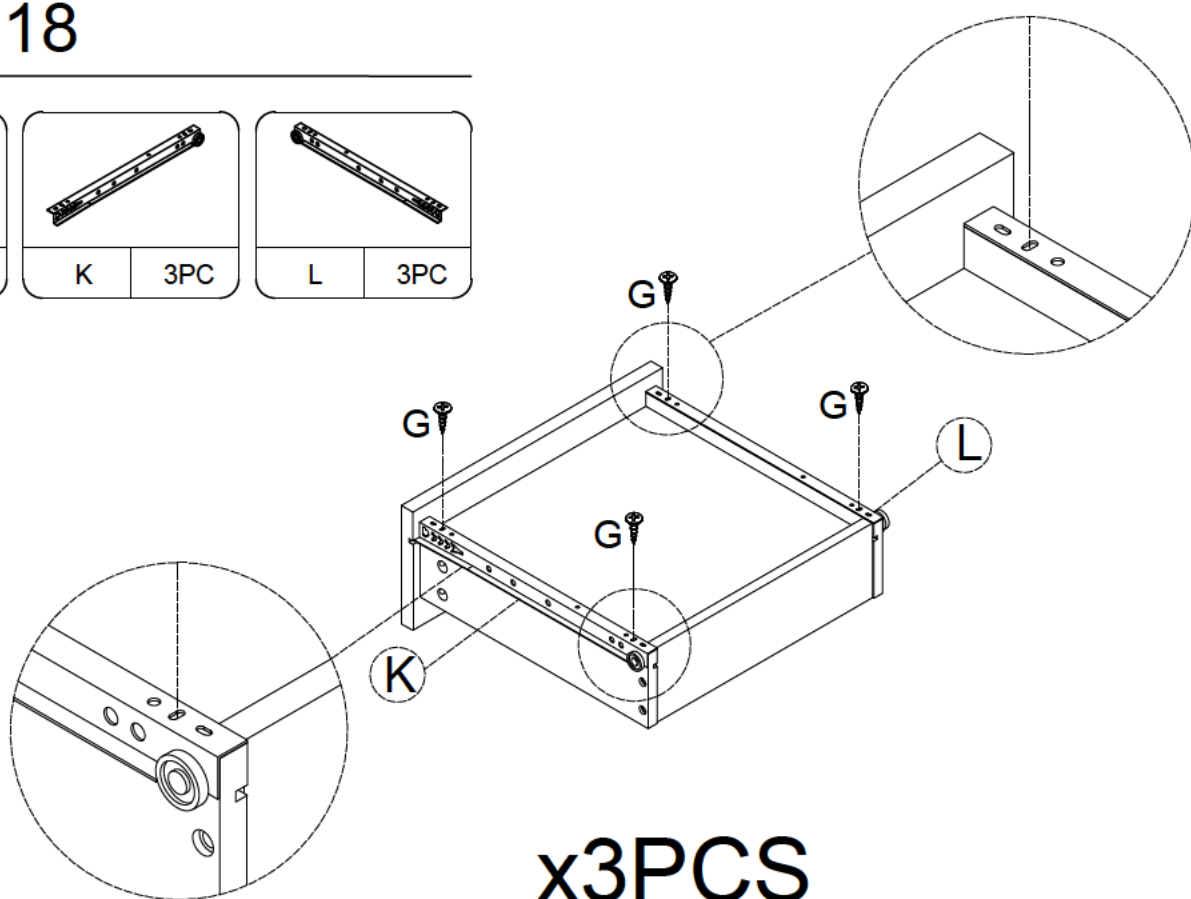
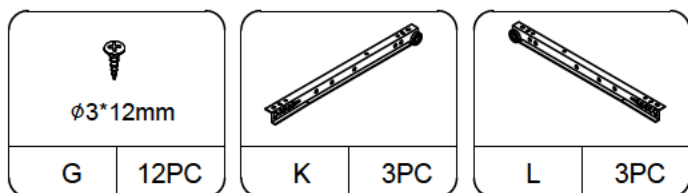

STEP 19

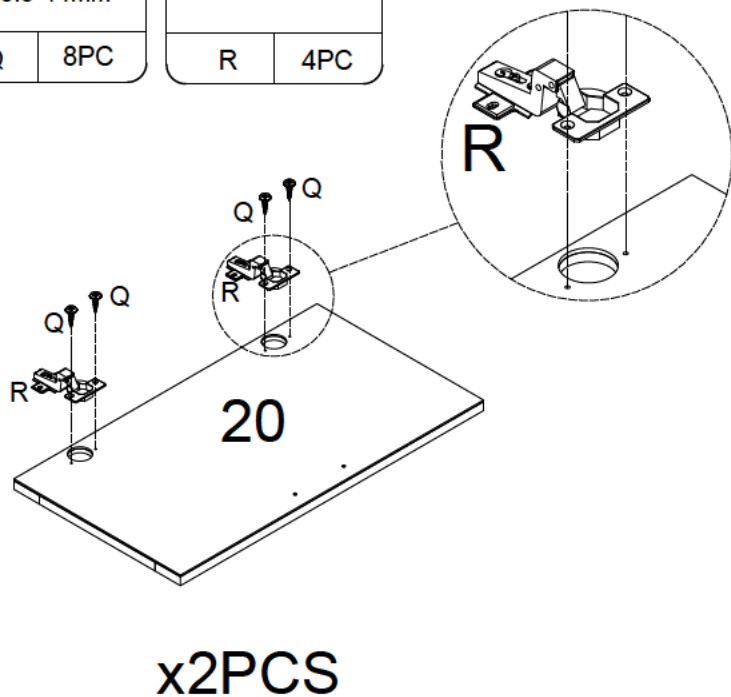
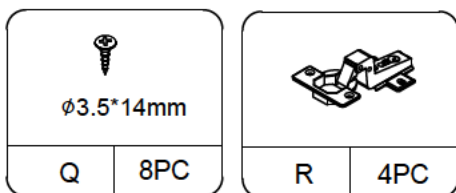

STEP 20

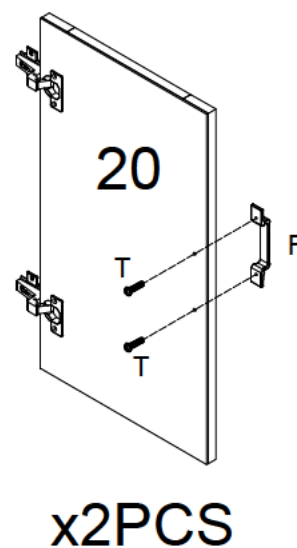
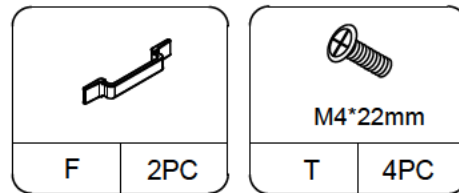

STEP 21

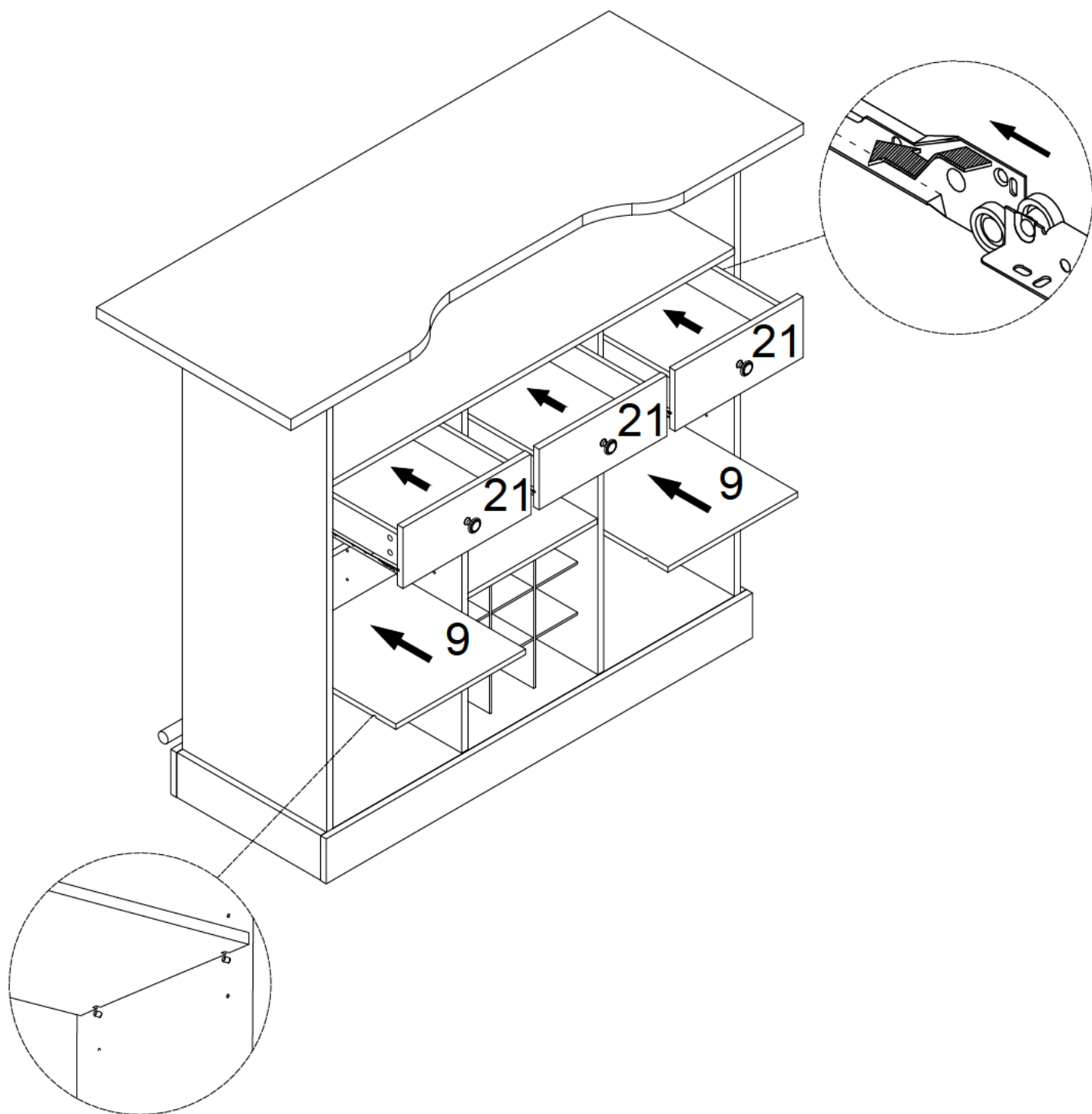

STEP 22

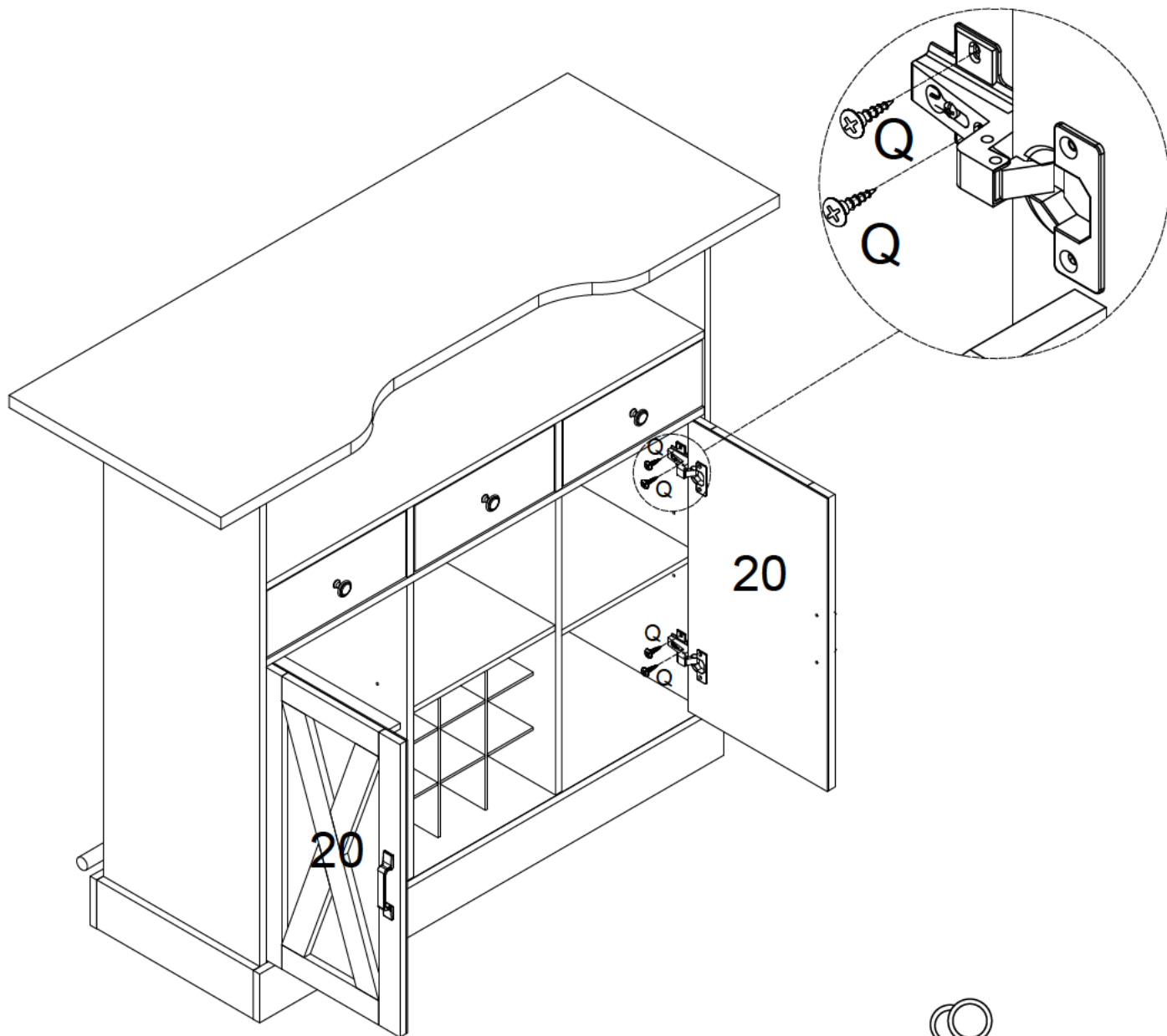
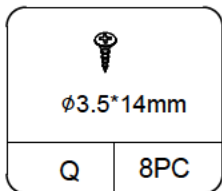

Important
2 people required
2 personnes requises
2 personas requeridas

STEP 23

