

ASSEMBLY INSTRUCTIONS

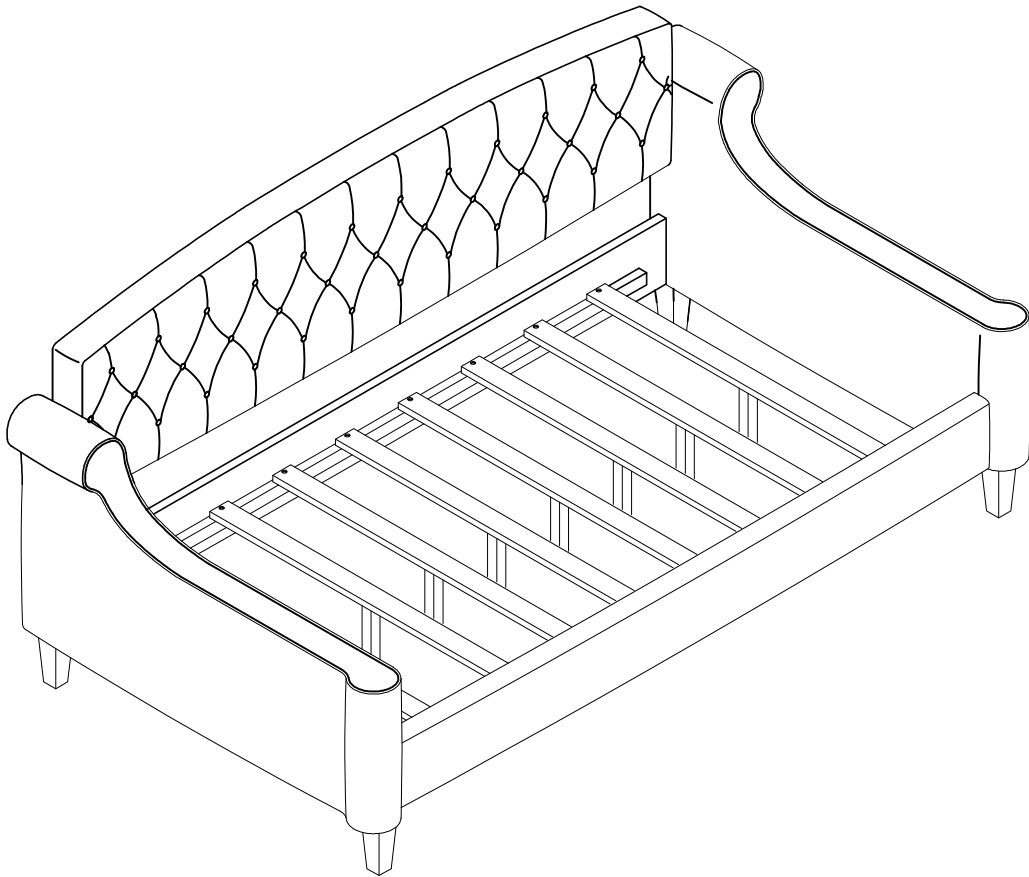

IMPORTANT NOTE:

** PLACE ALL PARTS ON A CLEAN AND SMOOTH SURFACE SUCH AS A RUG OR CARPET TO AVOID THE PARTS FROM BEING SCRATCHED.

**BEFORE YOU BEGIN , PLEASE REVIEW THE ASSEMBLY INSTRUCTIONS STEP BY STEP.

PARTS AND HARDWARE

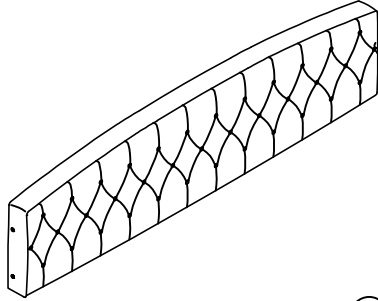

BED BACK (A) x 1PC

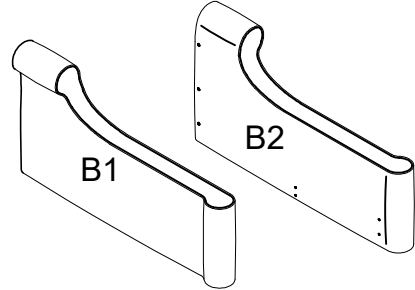

BED ARMEST (B) x 2PCS

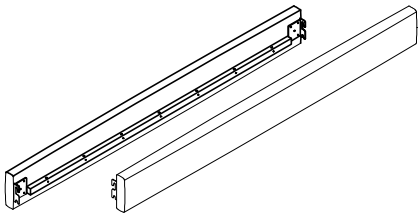

BED SIDE (C) x 2PCS

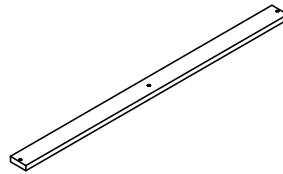

BED BATTEN (D) x 8PCS



MIDDLE LEGS (E) x 8PCS

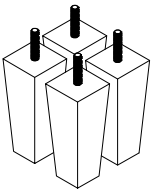

LEG (F) x 4PCS

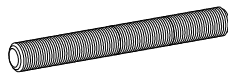

LONG BOLT (G) x 4PCS

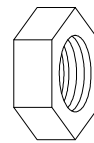

NUT (H) x 4PCS



FLAT WASHER (I) x 20PCS

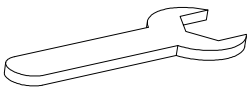

WRENCH (J) x 1PC



BOLT (K) x 8PCS



SCREW (L) x 16PCS



ALLEN KEY (M) x 1PC



PHILLIPS SCREWDRIVER
(NOT PROVIDED) (N) x 1PC

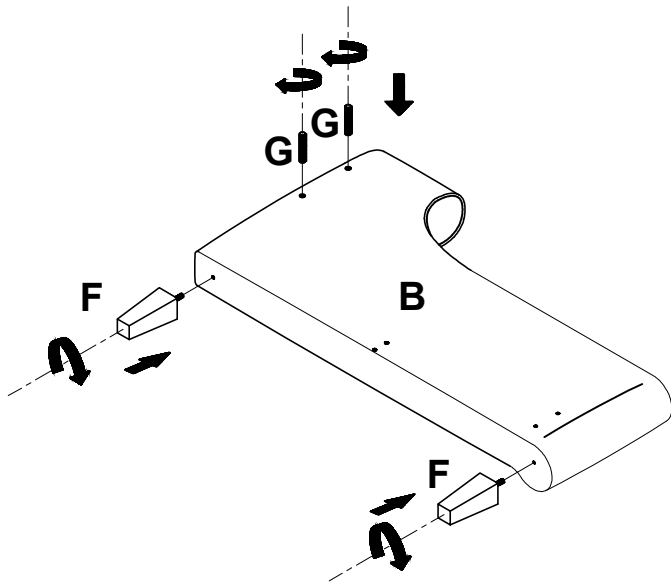

**** STEP 1: TIGHT THE LONG BOLTS(G) AND LEGS(F) TO THE BED ARMREST(B) .**

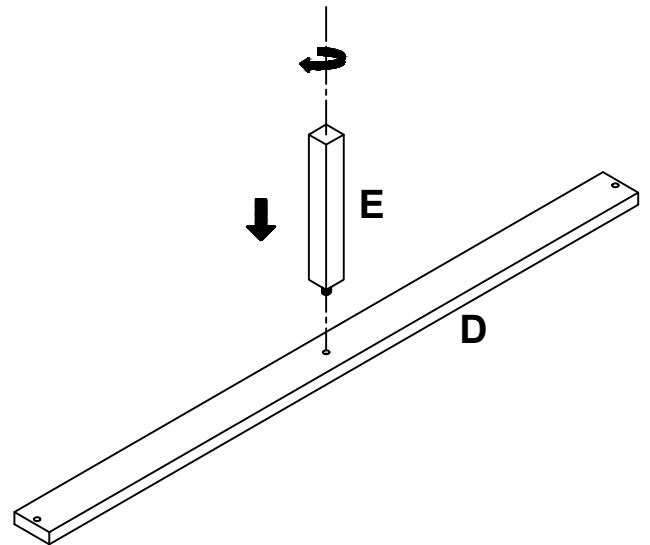

**** STEP 2:TIGHT THE MIDDLE LEGS(E) TO THE BED BATTEN(D).**

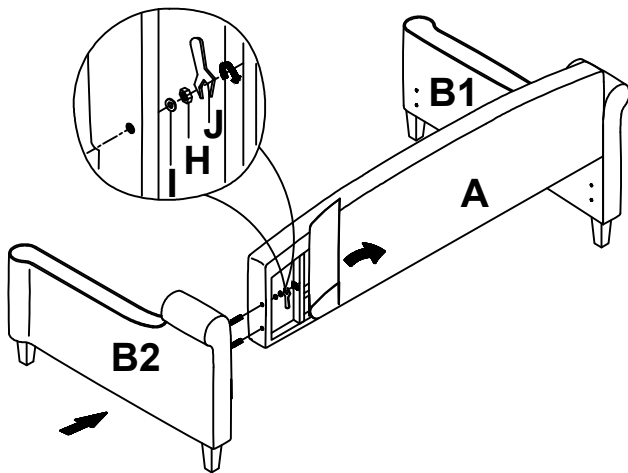

****STEP 3: ATTACH THE ARMRESTS(B) TO THE BED BACK(A). DO NOT TIGHTEN ALL NUTS.**

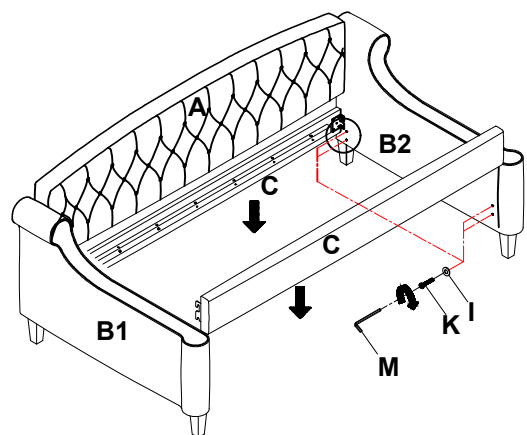

****STEP 4: ATTACH THE BED RAIL(C) TO THE BED ARMREST(B). DO NOT TIGHTEN ALL THE BOLTS.**

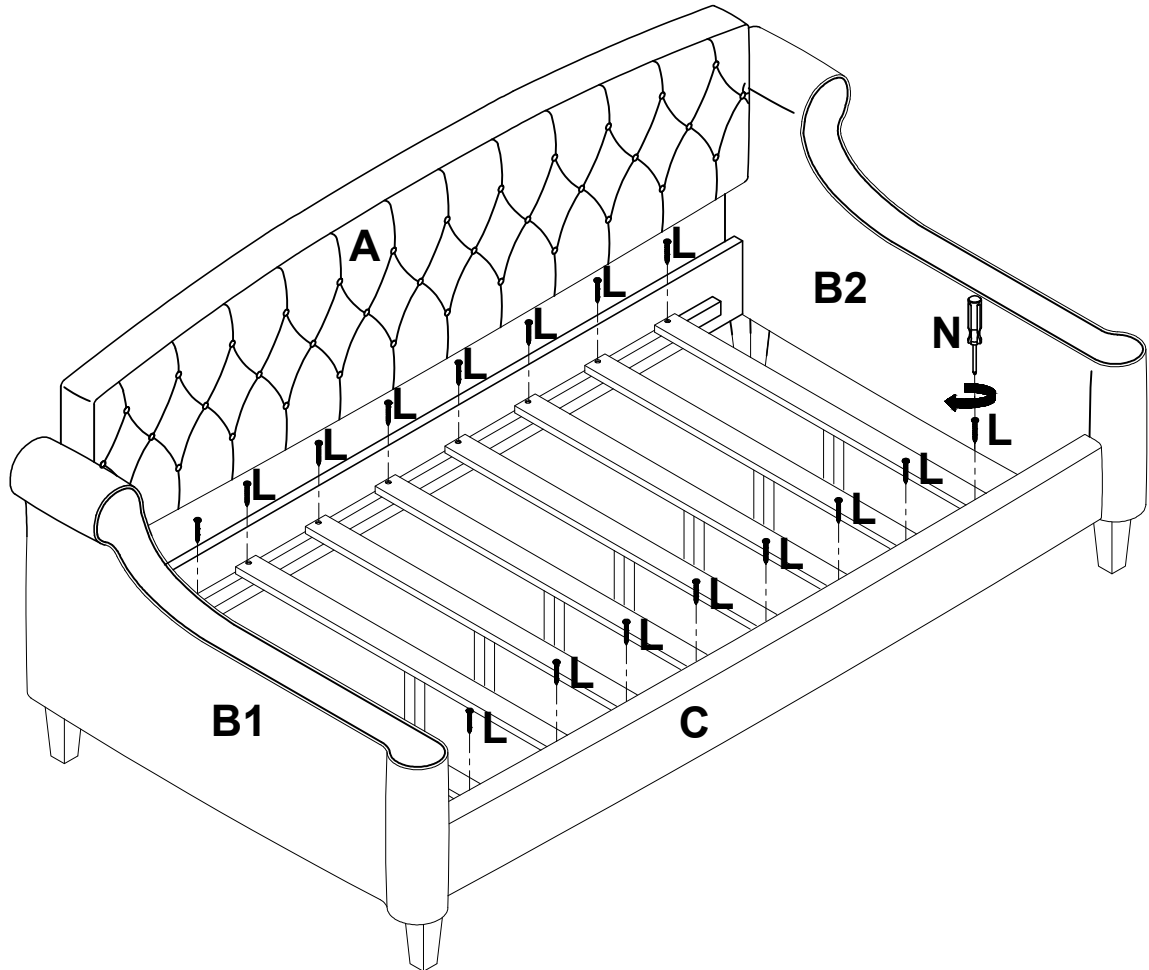

****STEP 5: ATTACH ALL THE BEDSTEAD INTO THE BED,
TIGHTEN ALL THE NUTS AND BOLTS AND SCREWS.
UNTIL NOW IS COMPELTED.**