

ASSEMBLY INSTRUCTIONS

DESCRIPTION: TABLE

Thank you for purchasing this quality product. Be sure to check all packing material carefully for small parts which may have come loose inside the carton during shipment. Identify and count all parts and compare with the parts list below:

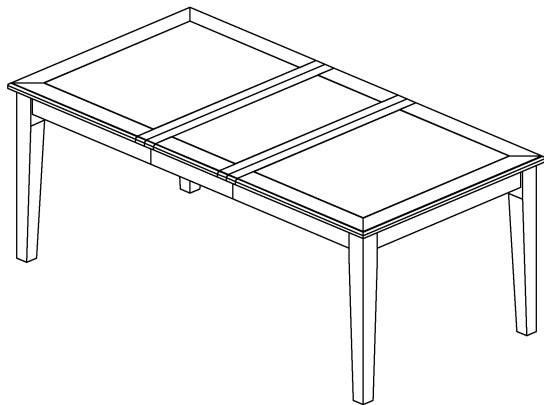

PARTS LIST

NO.	SKETCH	PARTS	Q'TY
1		TABLE TOP	1PC
2		TABLE LEAF	1PC
3		TABLE LEGS	4PCS

4

ASSEMBLY HARDWARE PACK

NO.	SKETCH	HARDWARE	Q'TY
A	$\frac{5}{16}'' \times 6\text{mm}$	NUT	8PCS
B	$\frac{5}{16}'' \times 13\text{mm}$	LOCK WASHER	8PCS
C	$\frac{5}{16}'' \times 16\text{mm}$	FLAT WASHER	8PCS
D	$\frac{5}{16}'' \times 90\text{mm}$	WRENCH	1PC

STEP 1:

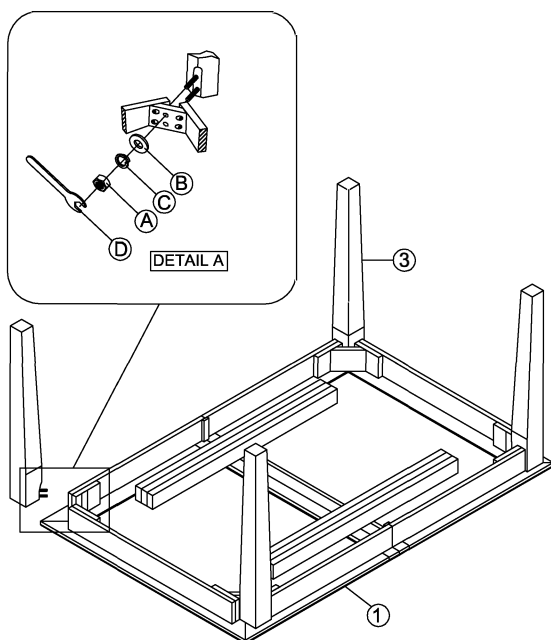

STEP 2:

