

WARRANTY

We strive to offer high-quality products, and we also try our best to satisfy each and every customer that orders from us with product or service as needed. We provide 30 days warranty starting from the time you receive the item. Each customer must provide a record of their order such as the order number, or item receipt for any items that are out of the warranty period you may also still receive replacement parts by purchasing them with our company if they are available.

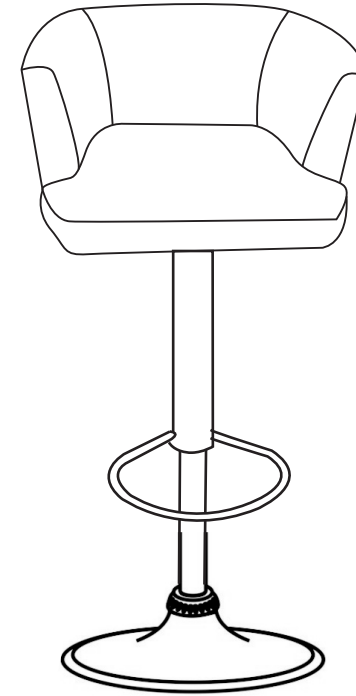

NOTE:

This brochure contains IMPORTANT safety info. Please read and keep for future reference.

MAINTAINANCE AND WARNING

- Keep furniture away from heat.
- Do not clean furniture with harsh cleansers or polish. Do not use detergents, Solvents, abrasives, spray packs or leather cleaner. Use non-color mild soap with warm water clean spills(Mix 1:10 soap to water)
- Do not place furniture under direct sunlight, material will possibly fade over time.
- Do not use on site dry Cleaning machine.
- Children should not climb or jump on the furniture.
- Do not write on furniture without a padded barrier to protect the surface.
- Not for commercial use, For residential use only.



Weight Limitation

250LBS

PARTS LIST

Ax1

Seat

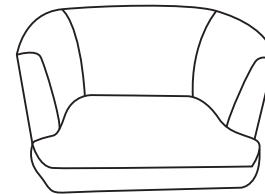

Bx1

Foot pedal

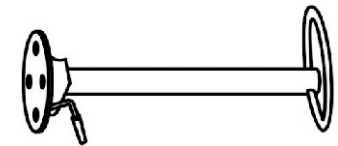

Cx1

Decorative plate



Dx1

Bar Dish



Ex1

Gas lift



HARDWARE LIST

Fx4
M6*40mm
Screw

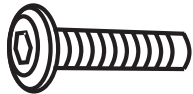

Gx1
M6
Allen Key

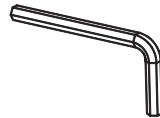

SPARE

Fx1
M6*40mm
Screw

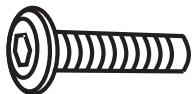

Be sure to check all packing material carefully for small parts, which may have come loose inside the carton during shipment.

ASSEMBLY INSTRUCTIONS

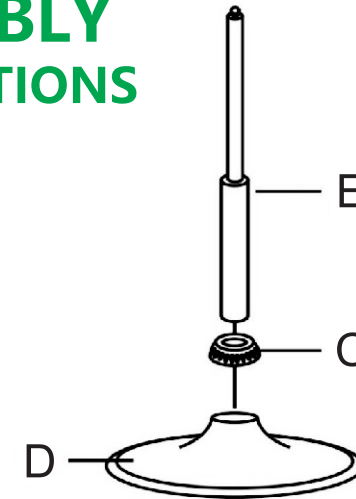

STEP 1: Insert gas lift E through decoration ring C to center hole of metal base D.

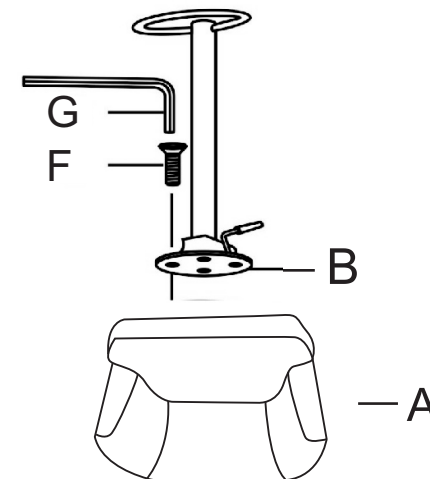

STEP 2: Place the chair back A on a clean padded surface, Use bolt F, allen key G to attach mechanism B to bottom of the seat A.

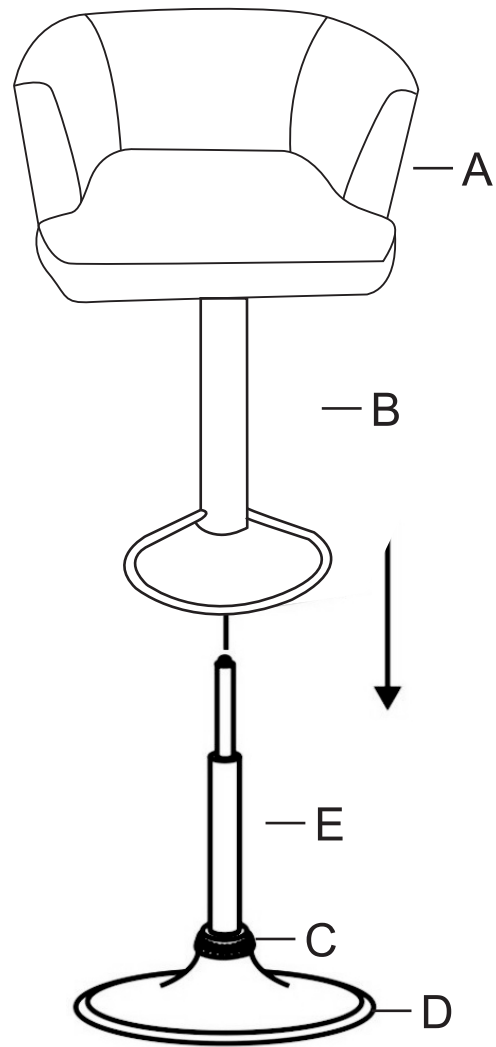

STEP 3:Carefully align bottom hole of mechanism with top pin of gas lift then push all the way down to secure.

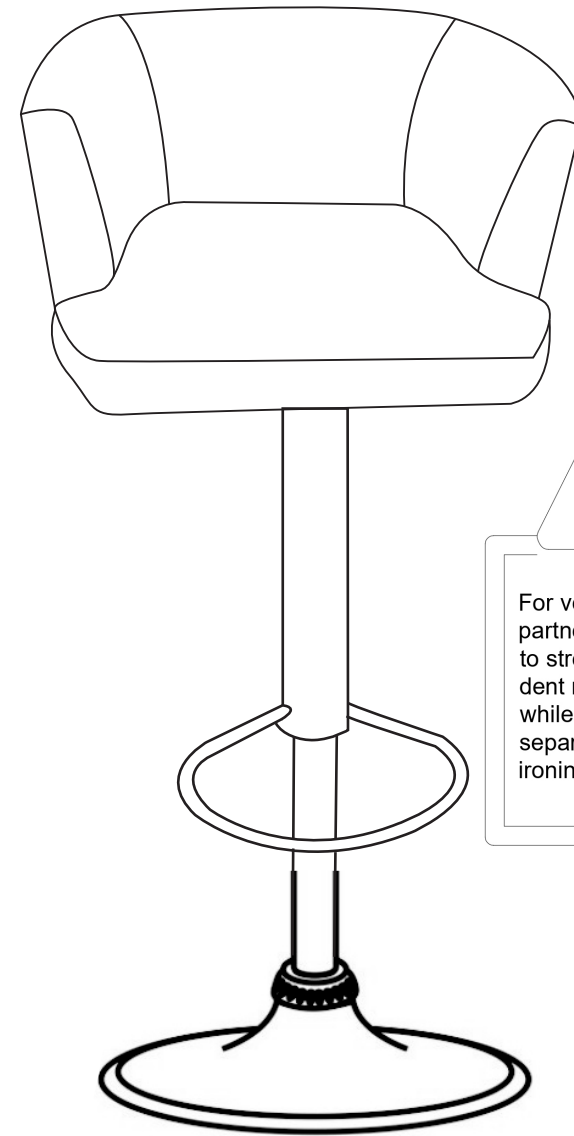

STEP 4 :Assembly completed.



For velvet:With help of adult partner, Iron the fabric cover to stretch the wrinkles and dent mark with steam iron while necessary.please separate with a towel before ironing..