

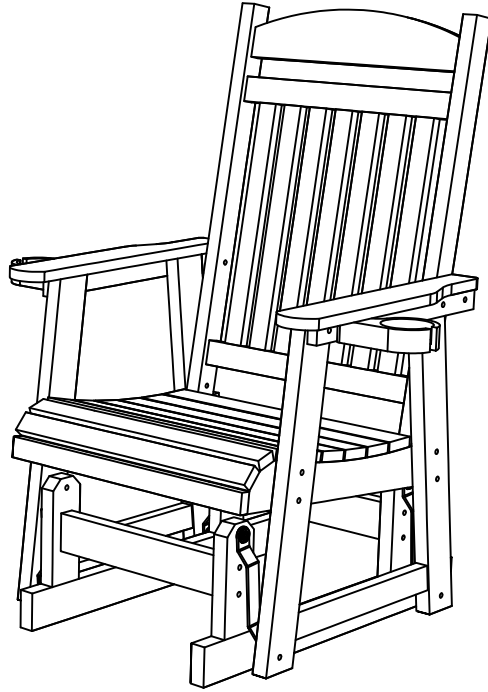

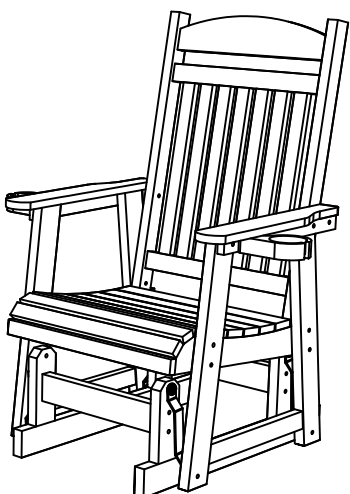

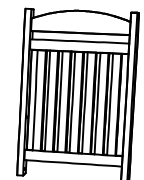

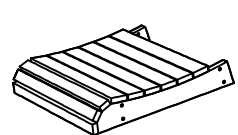

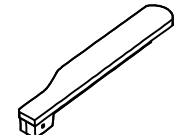
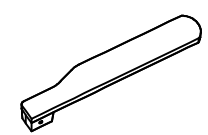
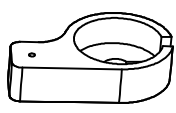
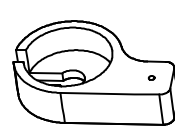
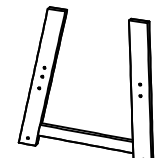
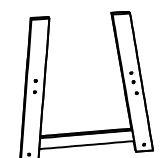

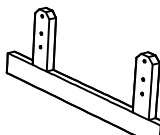
User's Manual

Patio Glider

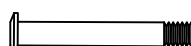
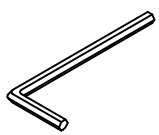
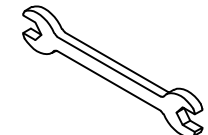

				
	A x 1	B x 1	C x 1	D x 1
				
	E x 1	F x 1	G x 1	H x 1
				
	I x 2	J x 2	AA x 4	BB x 8 M6*50
				
	M6*60	M6*70	M6*50	M6*60
	CC x 4	DD x 8	EE x 2	FF x 8
				
M6*70	M6*50	Tools		
GG x 2	HH x 2			

Precautions before Assembly

1. If any parts are missing or scratched or damaged, please contact the seller or customer service for partial refund and replacement parts.
2. In each assembly step, the screws only need to be tightened 80%, which will make it easier to assemble different parts. In the last step, please tighten the screws as tight as possible.

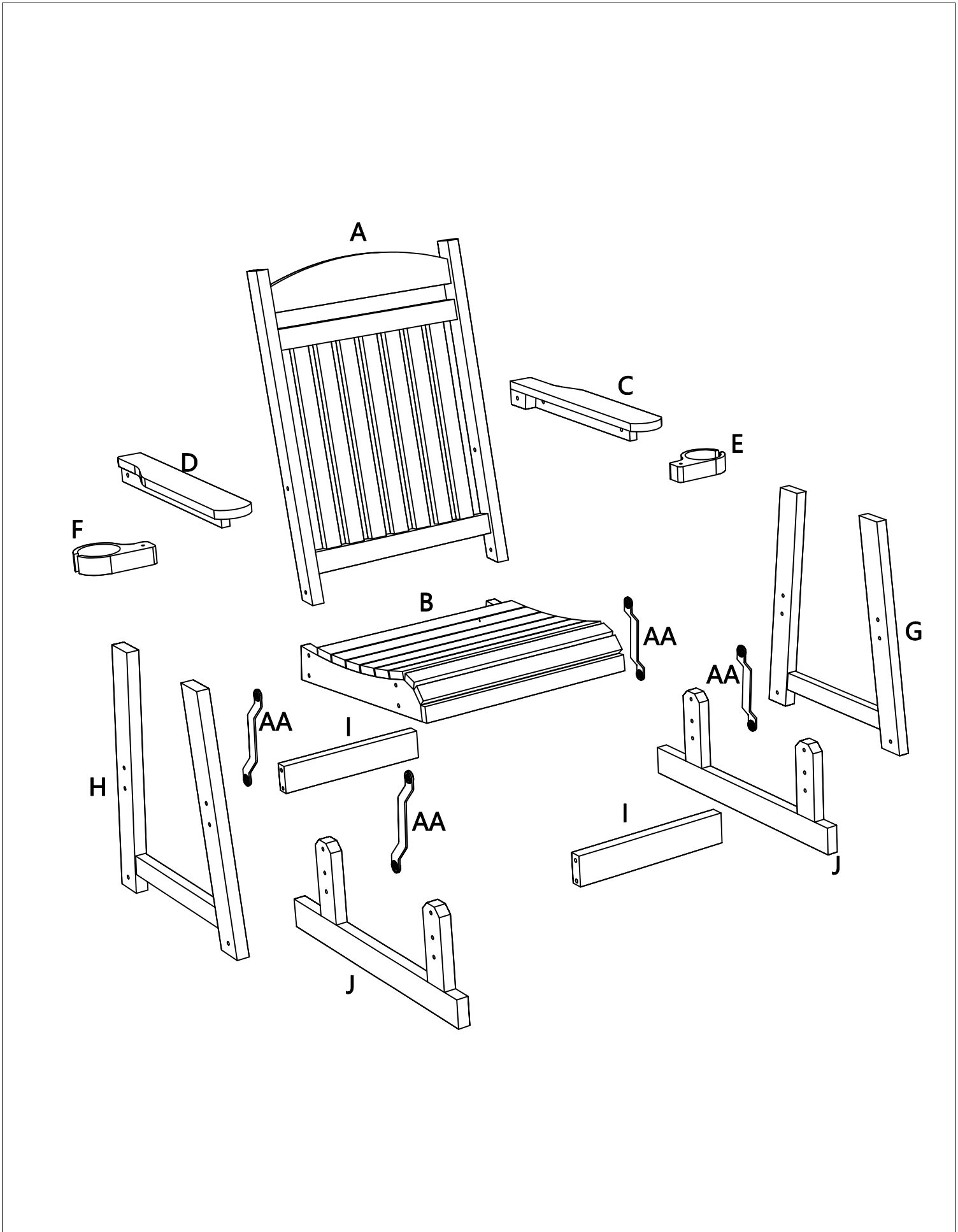

1

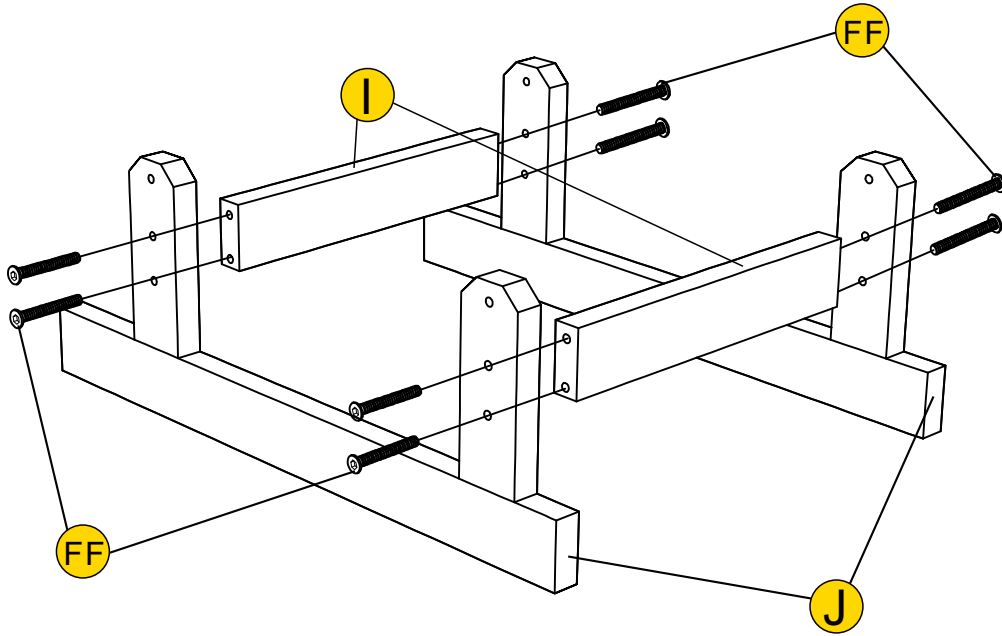

1. Assembling the base of the glider.

2

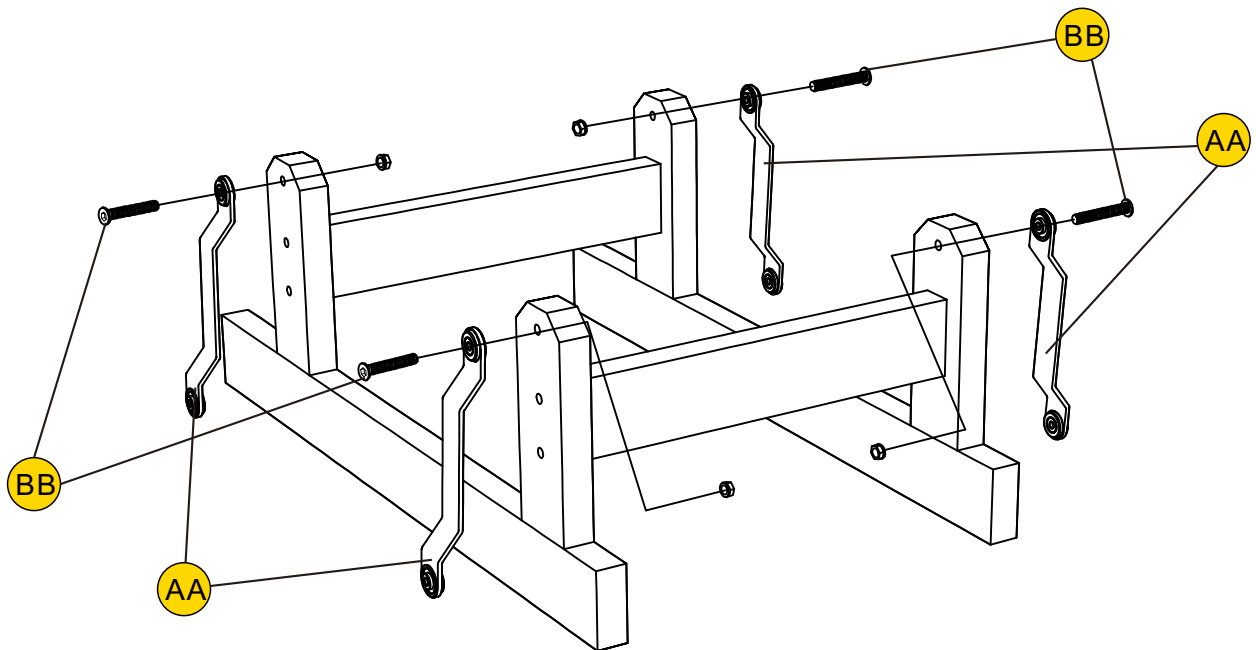

2. Assembling the metal connectors.

3

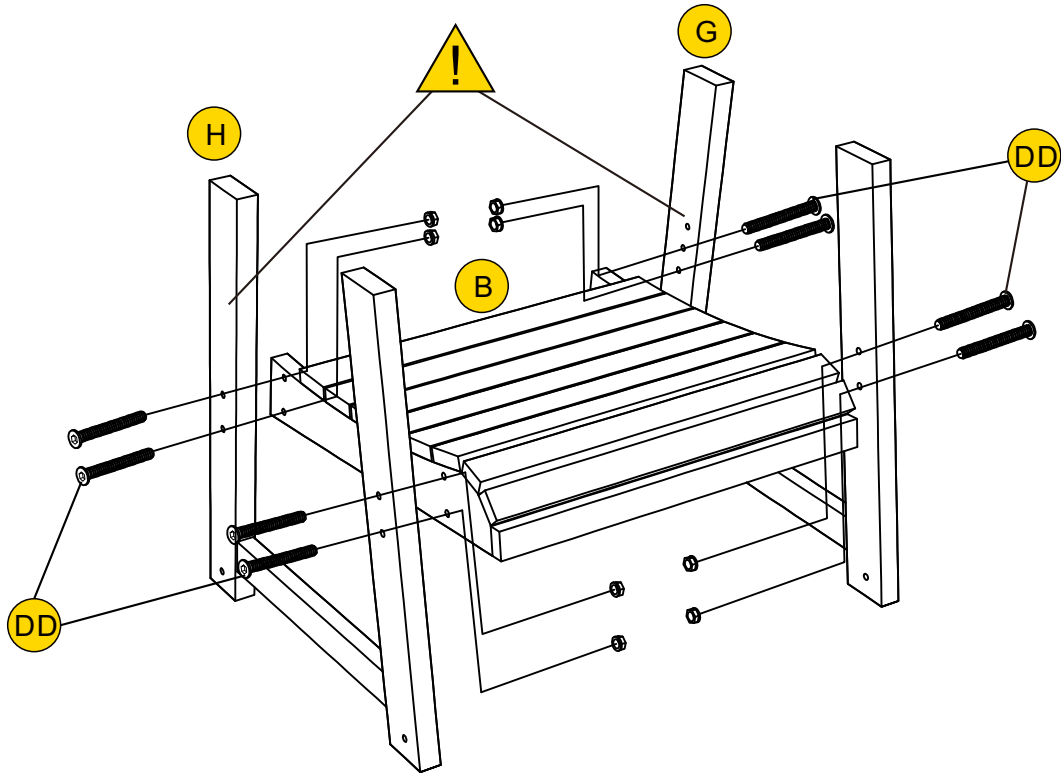

3. ⚠ Please note that the side of H and G parts with 3 screw holes should be installed on the side close to the backrest. The third screw hole is used to install the backrest.

4

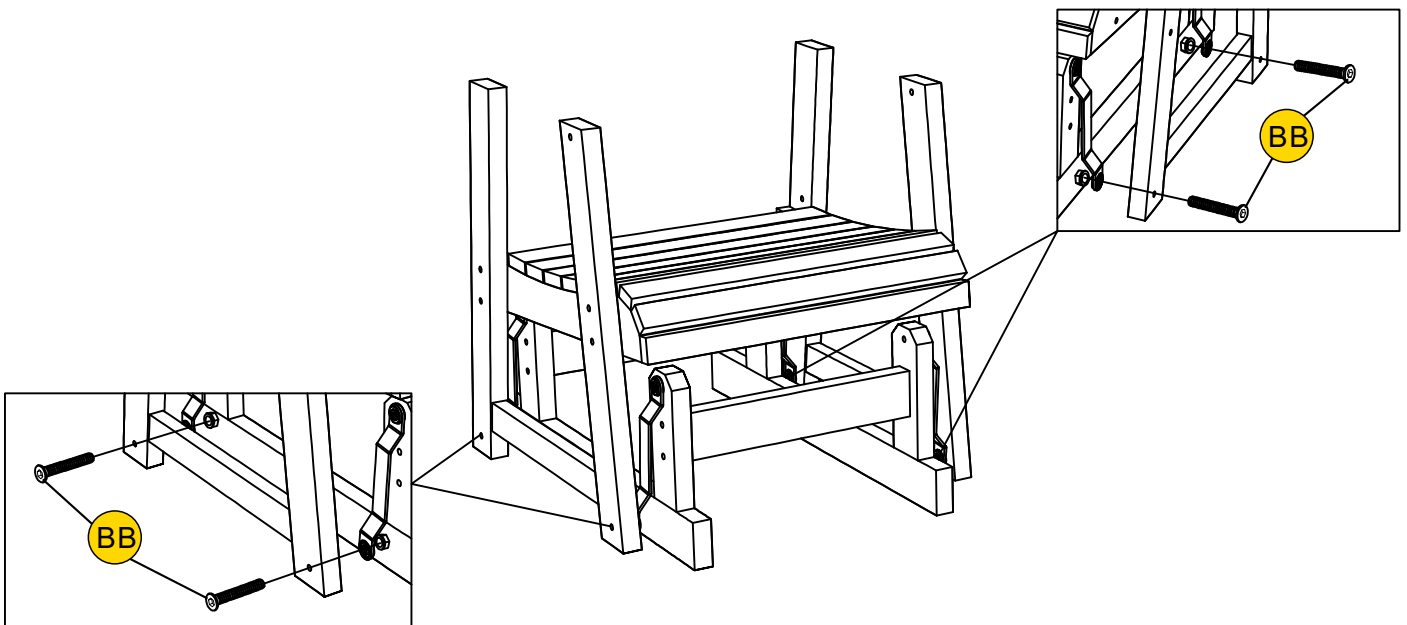

4. We recommend that two people work together for this step.

5

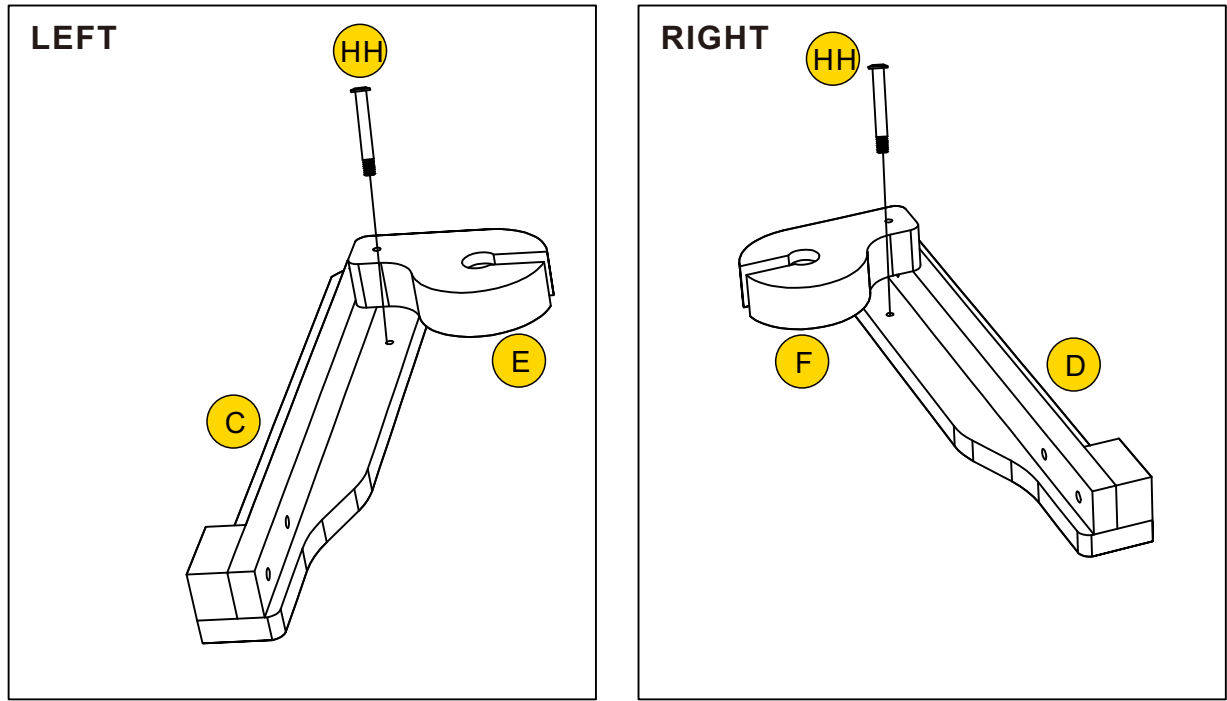

5. Assembling the cup holders.

6

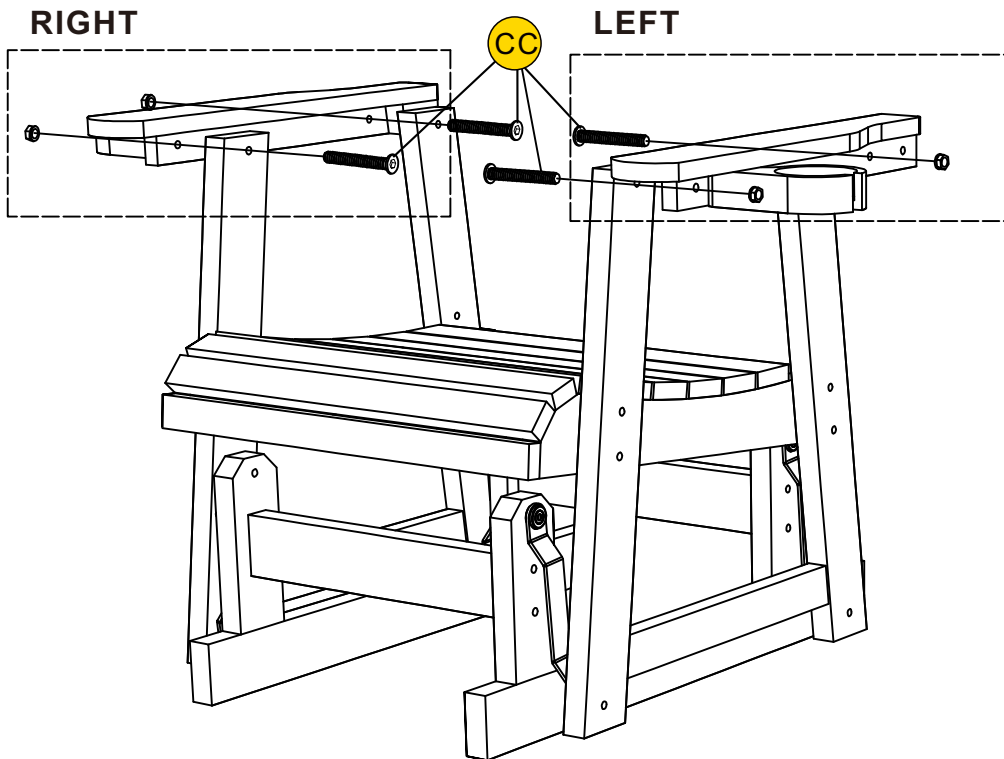

6. In this step we install the two armrests. Please note the distinction between left and right armrests.

7

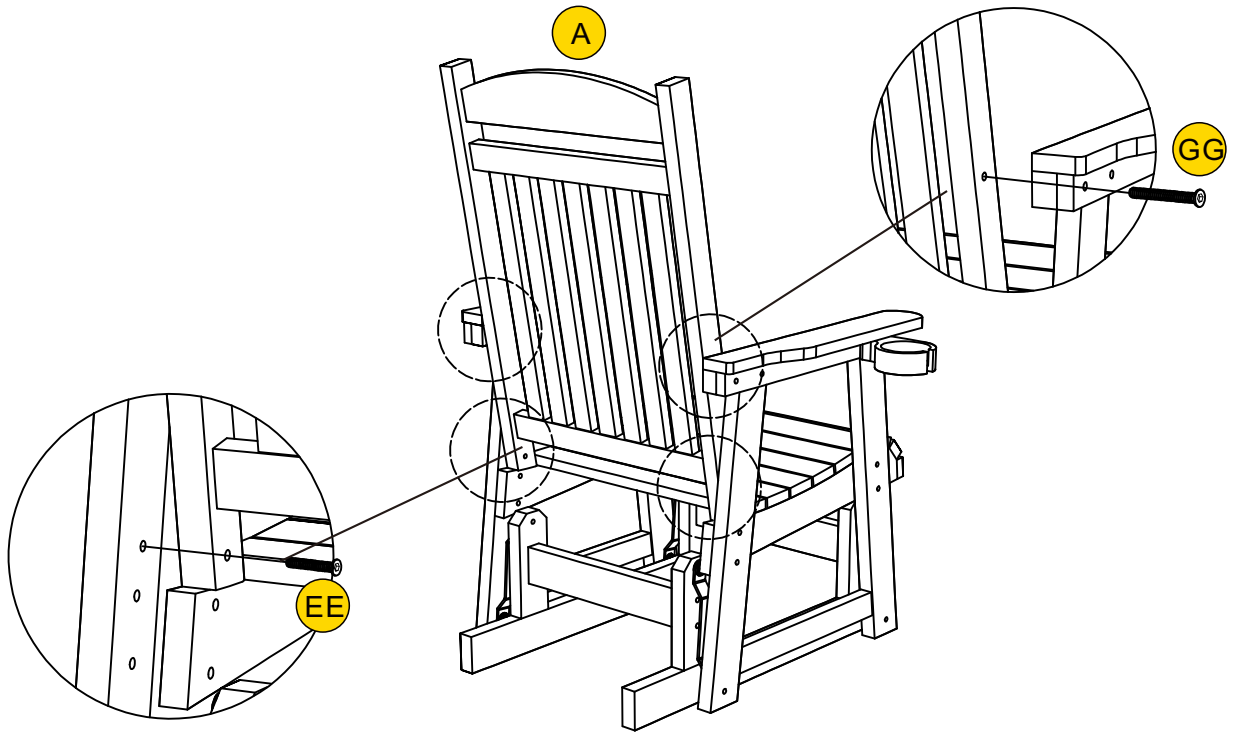

7. The Part A has no distinction between front and back, you can choose the side you like as the front.

8

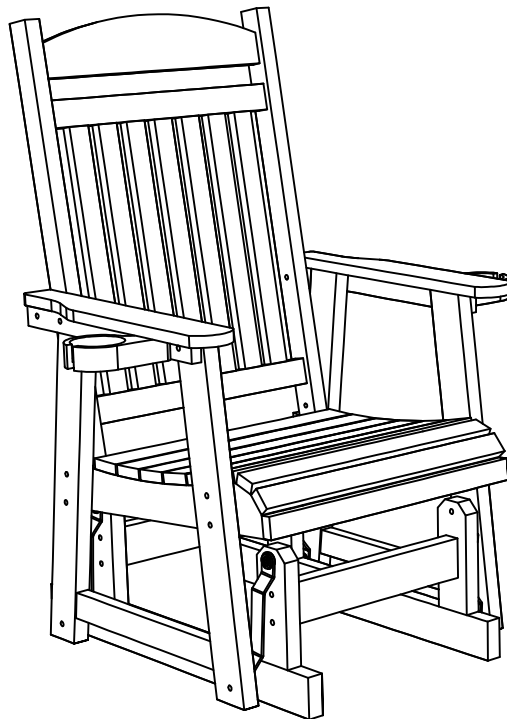

8. After all the parts are assembled correctly, please tighten the screws and nuts to the tightest, so that the glider can reach the maximum bearing capacity.