

ASSEMBLY INSTRUCTION FURNITURE



ASSEMBLY INSTRUCTION

ASSEMBLY TIPS:

1. Remove hardware from box and sort by size.
2. Please check to see that all hardware and parts are present prior to start of assembly.
3. Please follow attached instructions in the same sequence as numbered to assure fast & easy assembly.



Warning!





1. Don't attempt to repair or modify parts that are broken or defective. Please contact the store immediately.
2. This product is for home use only and not intended for commercial establishments.

ASSEMBLY TIME PER UNIT: 10MINUTES

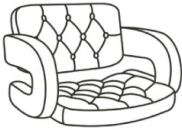
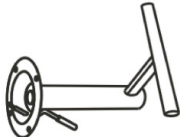

PARTS IDENTIFICATION



NOTE: QUANTITIES SHOWN ARE FOR ONE CHAIR

A-SEAT		1PC	B-FOOTREST		1PC
C-BASE		1PC	D-GAS CYLINDER		1PC
E-COVER RING		1PC			

Z HARDWARE PACKAGE

NO	DESCRIPTION	FIGURE	Q'TY
1	BOLTS M6x16mm		4PCS
2	ALLEN WRENCH M6		1PCS

ASSEMBLY INSTRUCTION

STEP 1

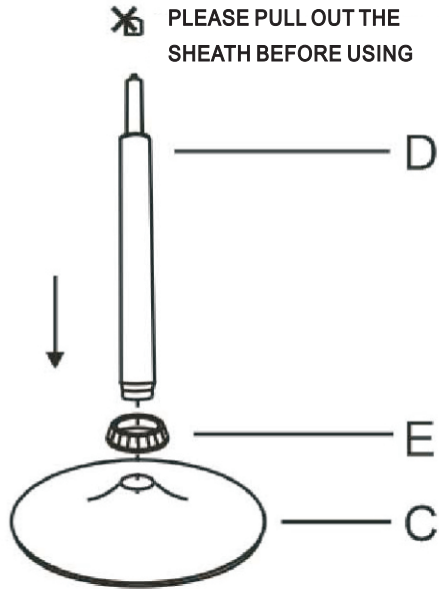

STEP 2

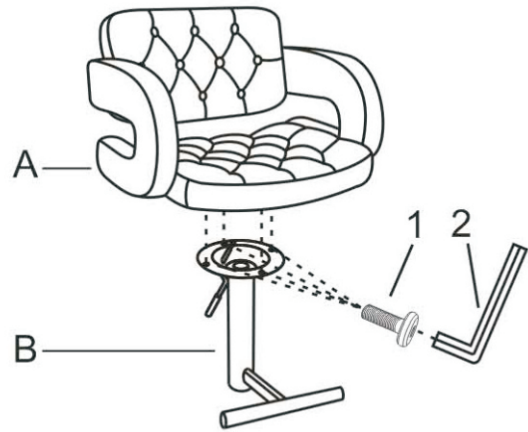

STEP 3

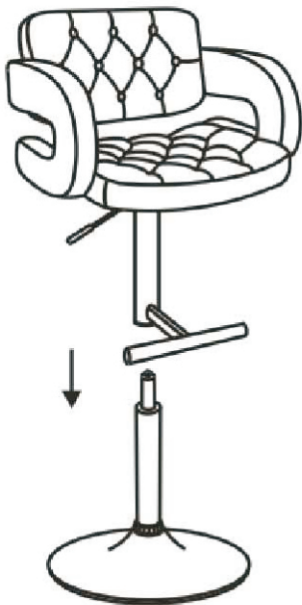

STEP 4

