

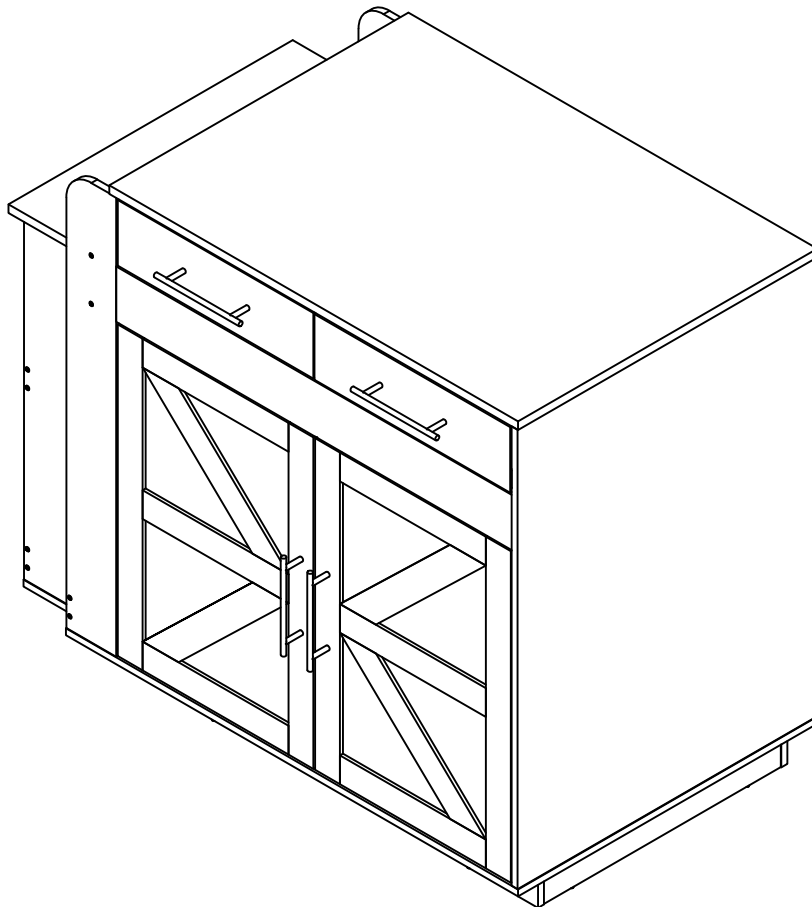

INSTRUCTIONMANUAL

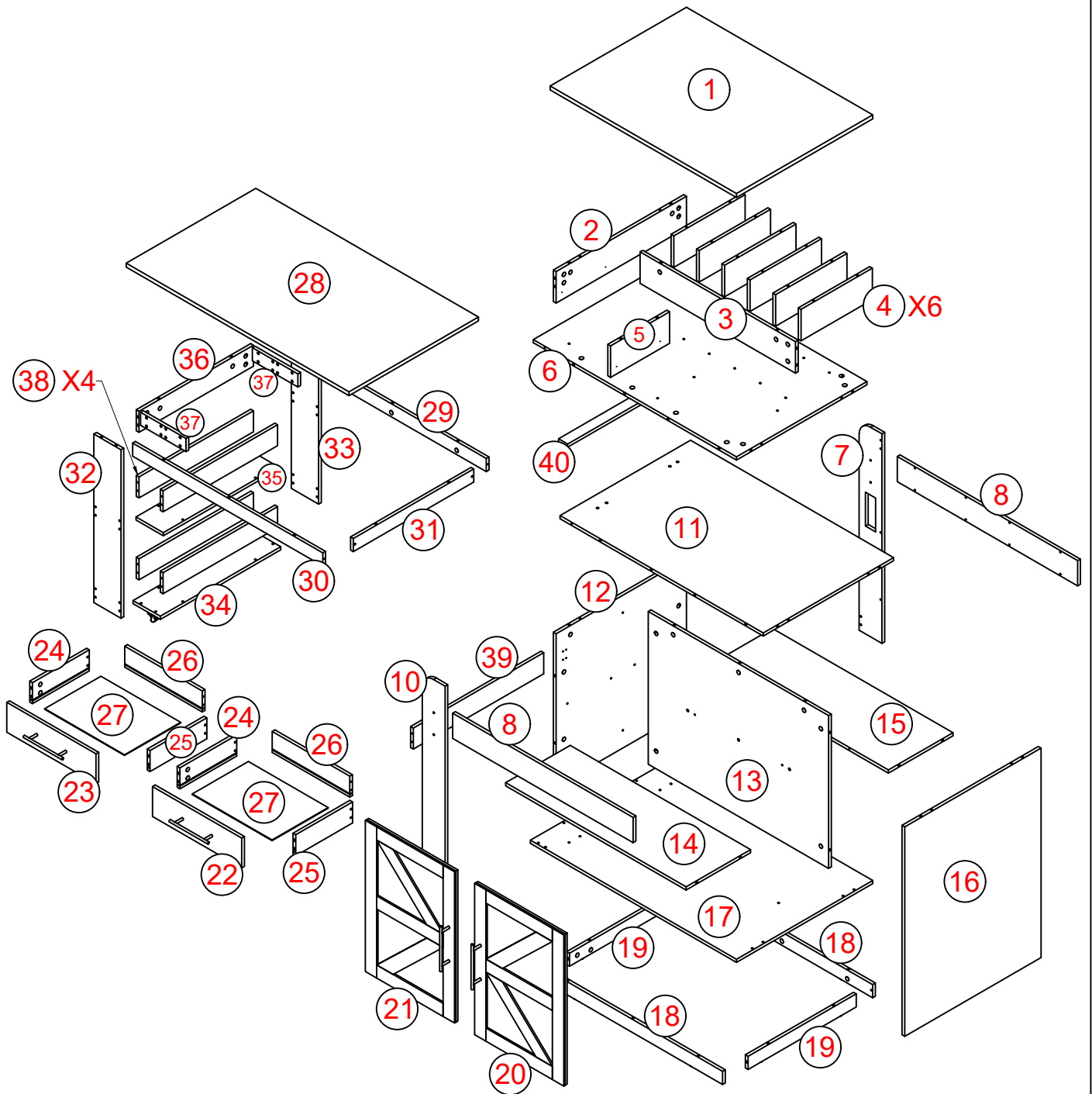



1

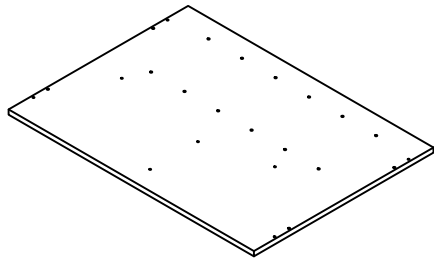

1 PC

2

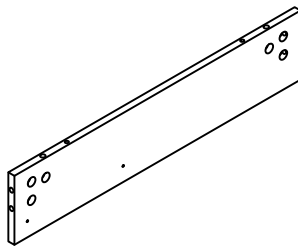

1 PC

3

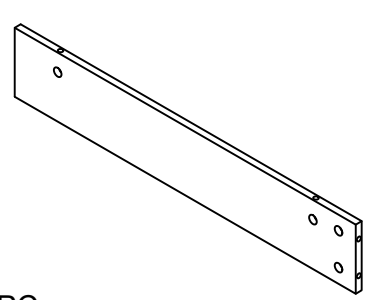

1 PC

4

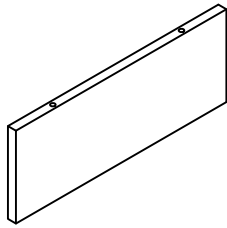

6 PCS

5

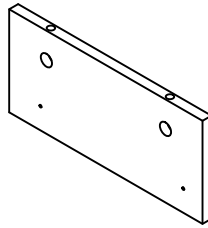

1 PC

6

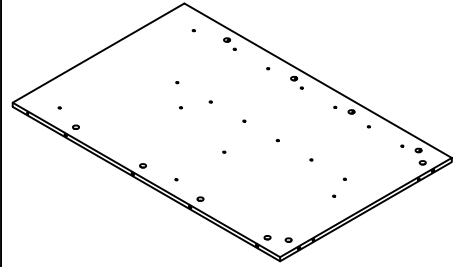

1 PC

7



1 PC

8

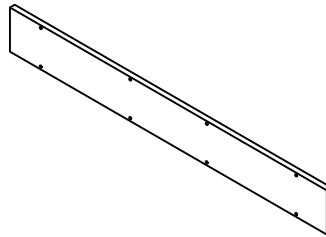

2 PCS

10



1 PC

11

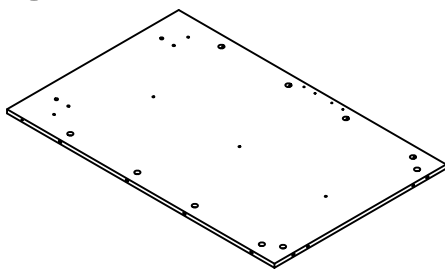

1 PC

12

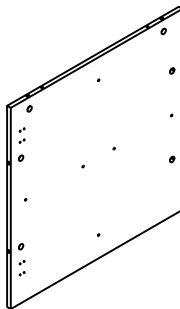

1 PC

13

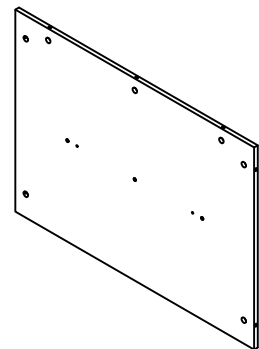

1 PC

14

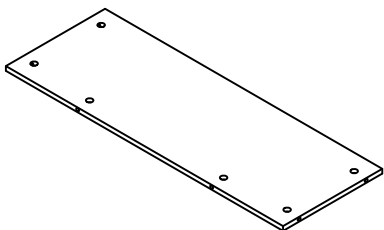

1 PC

15

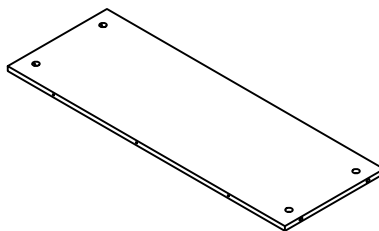

1 PC

16

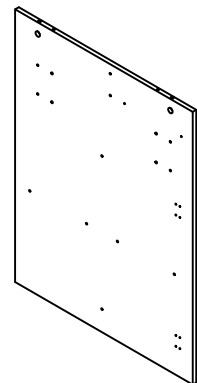

1 PC

17

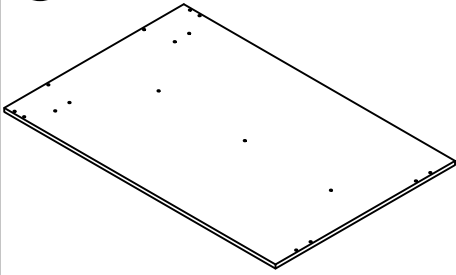

1 PC

18

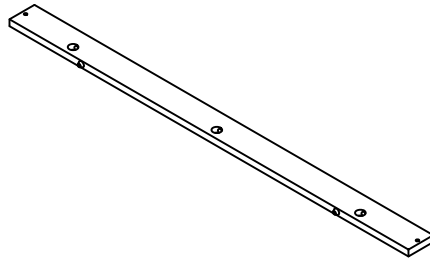

2 PCS

19

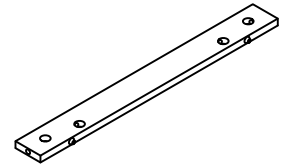

2 PCS

20

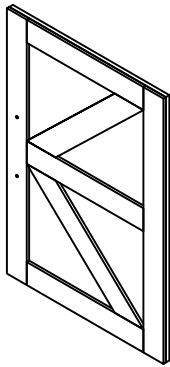

1 PC

21

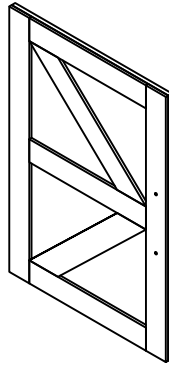

1 PC

22

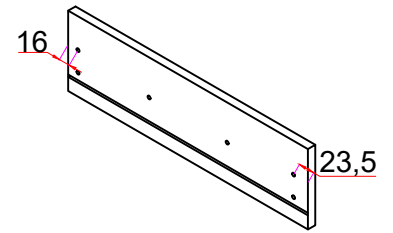

1 PC

23

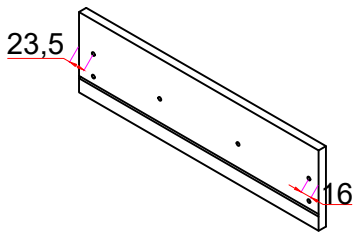

1 PC

24

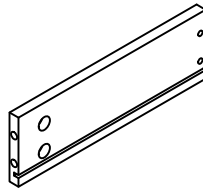

2 PCS

25

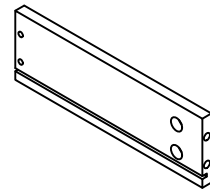

2 PCS

26

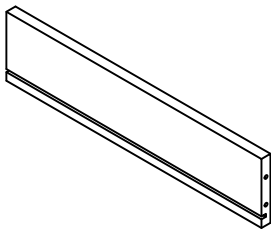

2 PCS

27

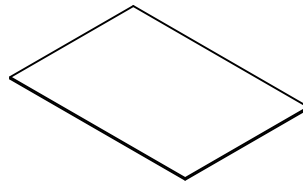

2 PCS

28

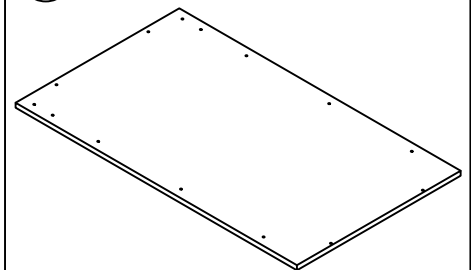

1 PC

29

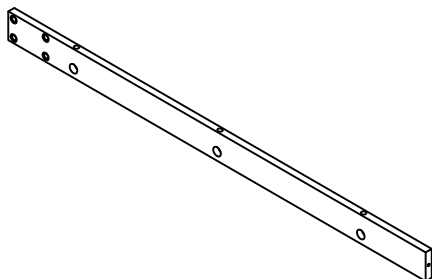

1 PC

30

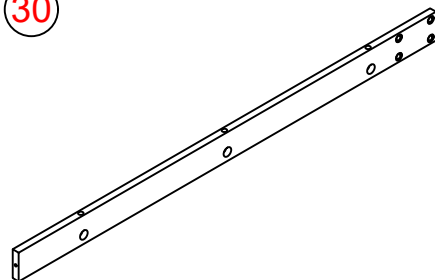

1 PC

31

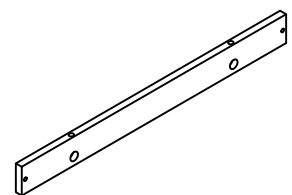

1 PC

32

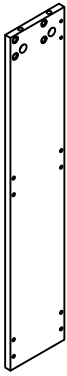

1 PC

33

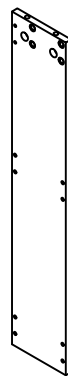

1 PC

34

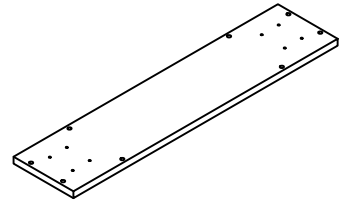

1 PC

35

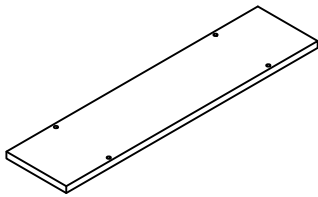

1 PC

36

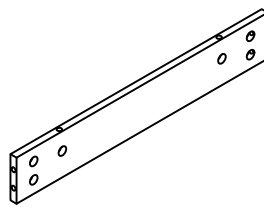

1 PC

37

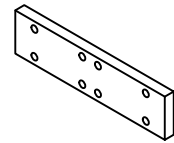

2 PCS

38

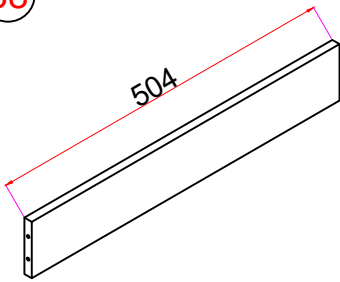

4 PCS

39

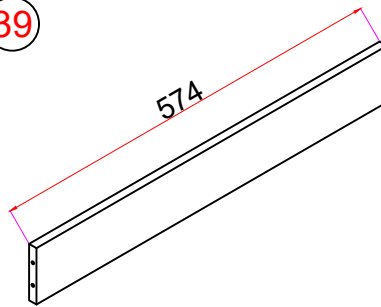

1 PC

40

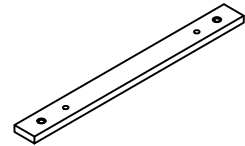

1 PC

Step: 1

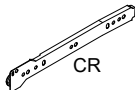
F	 M3.5X12	2
L	 CR	1

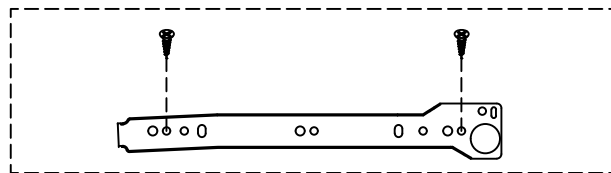
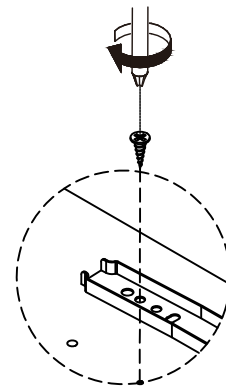
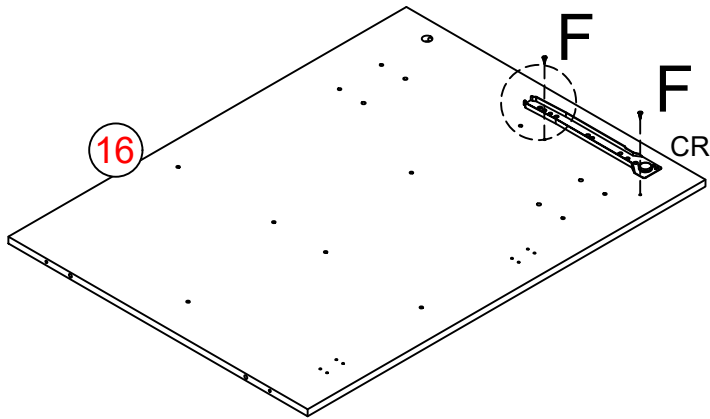

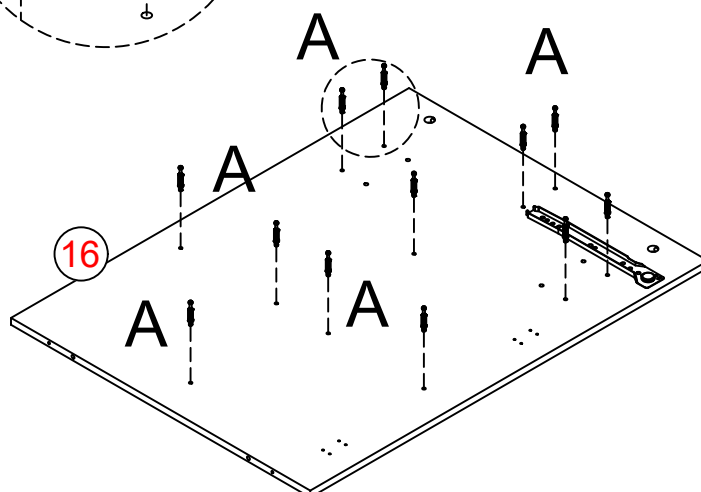
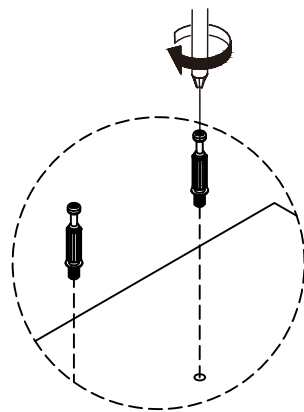

Step: 2

A	 M5X42	12
---	--	----

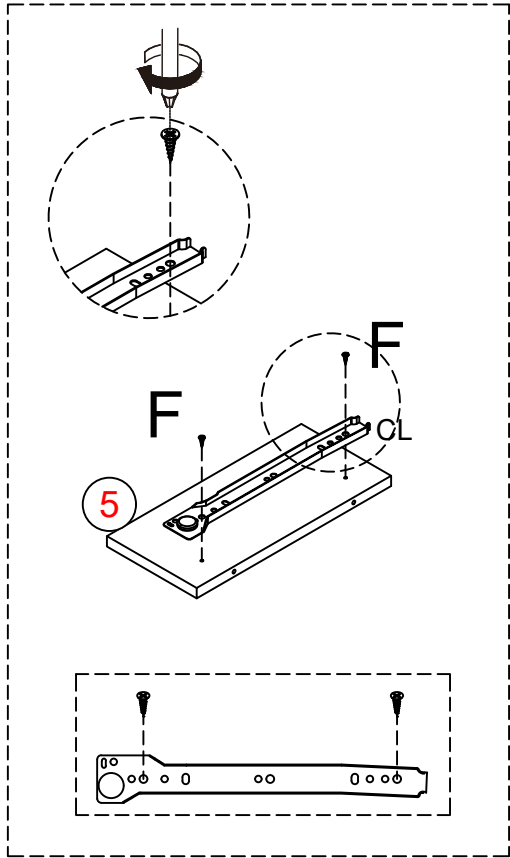

Step: 3

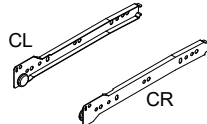

F	 M3.5X12	4
L		2

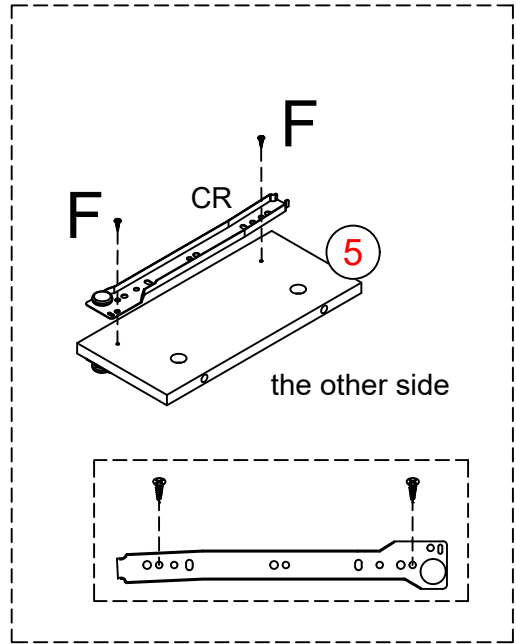

Step: 4

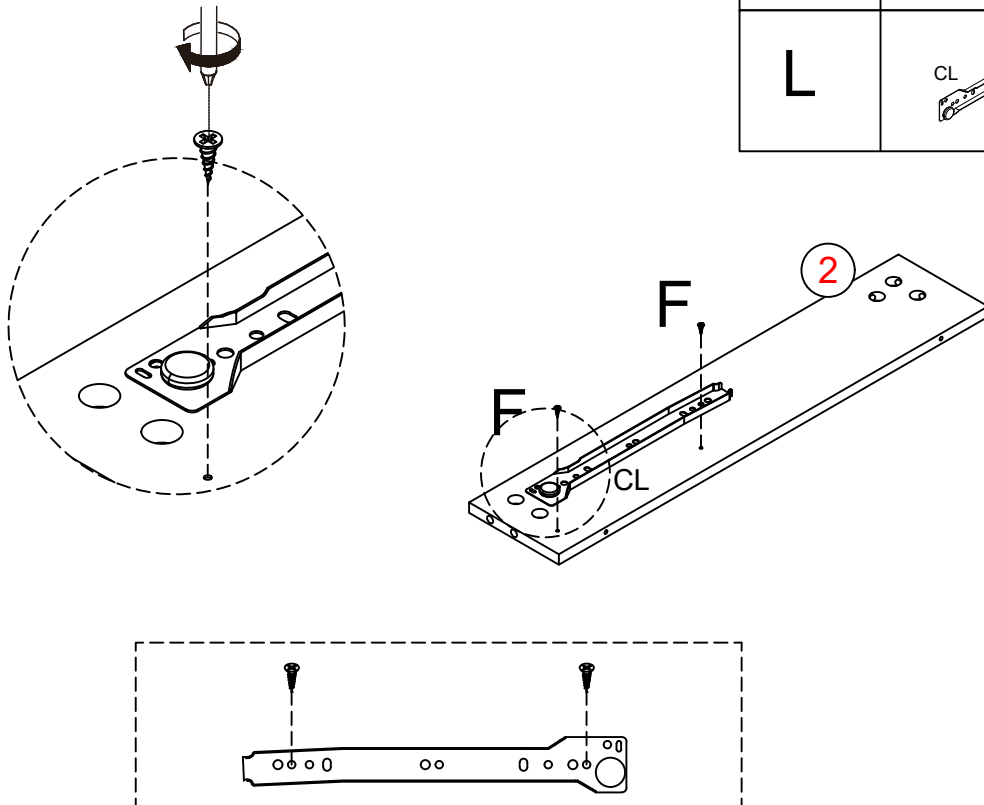

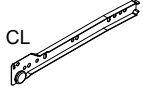
F	 M3.5X12	2
L		1

Step: 5

C



3

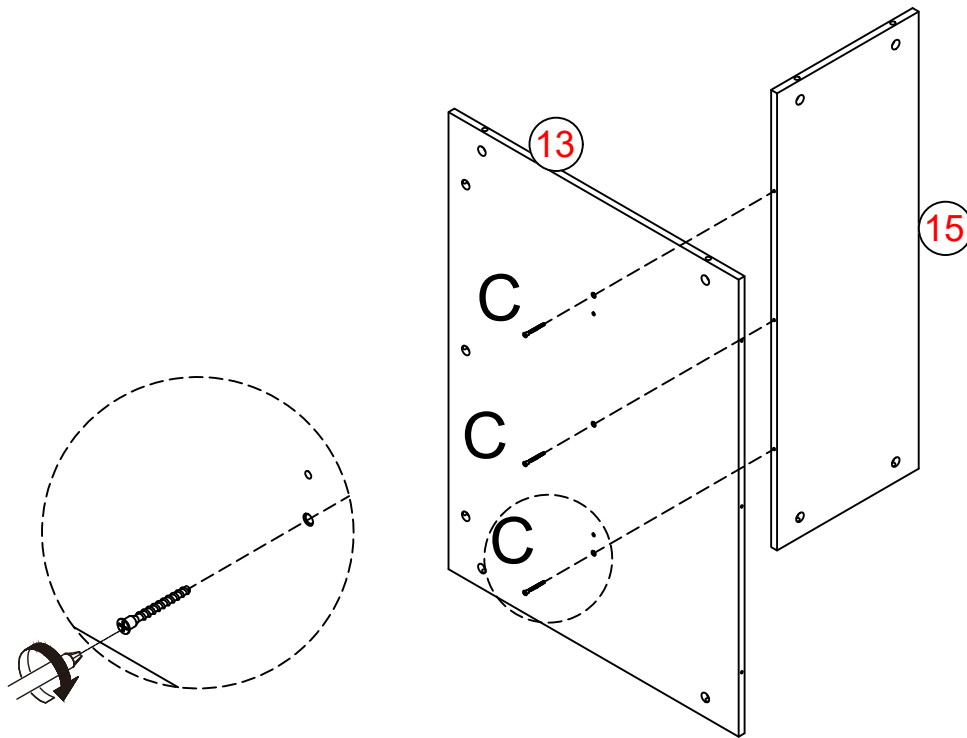

Step: 6

A

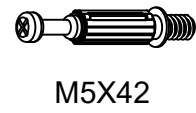

2

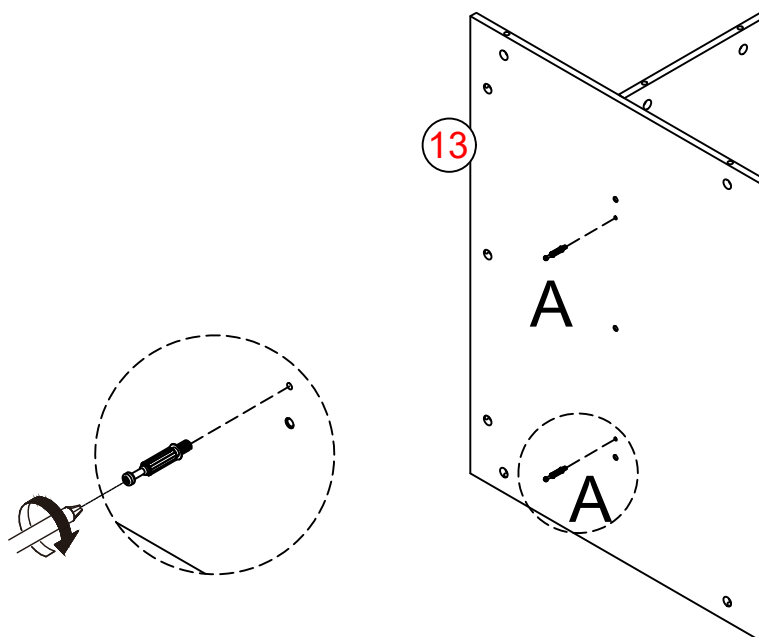

Step: 7

B



2

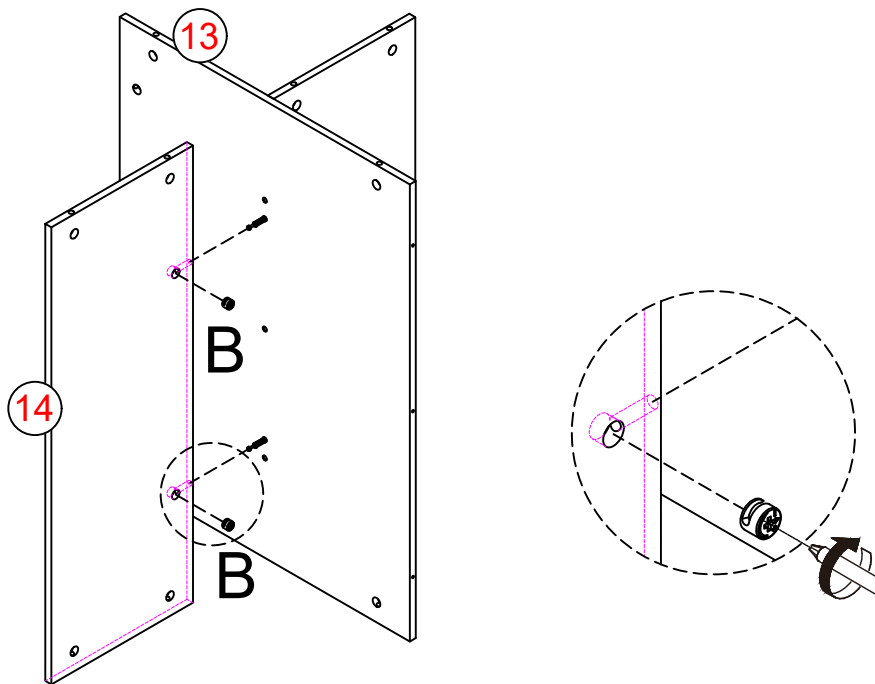

Step: 8

A

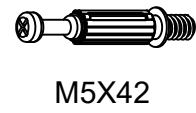

6

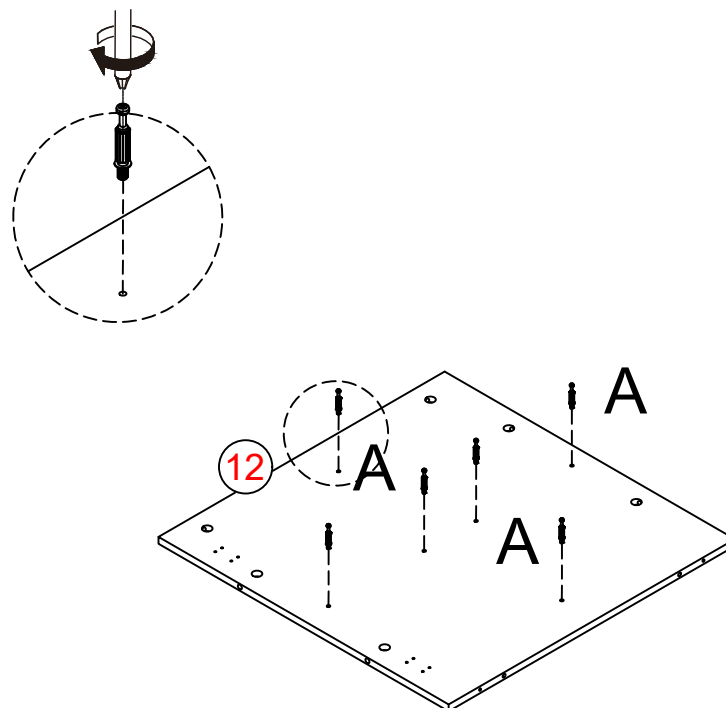

Step: 9

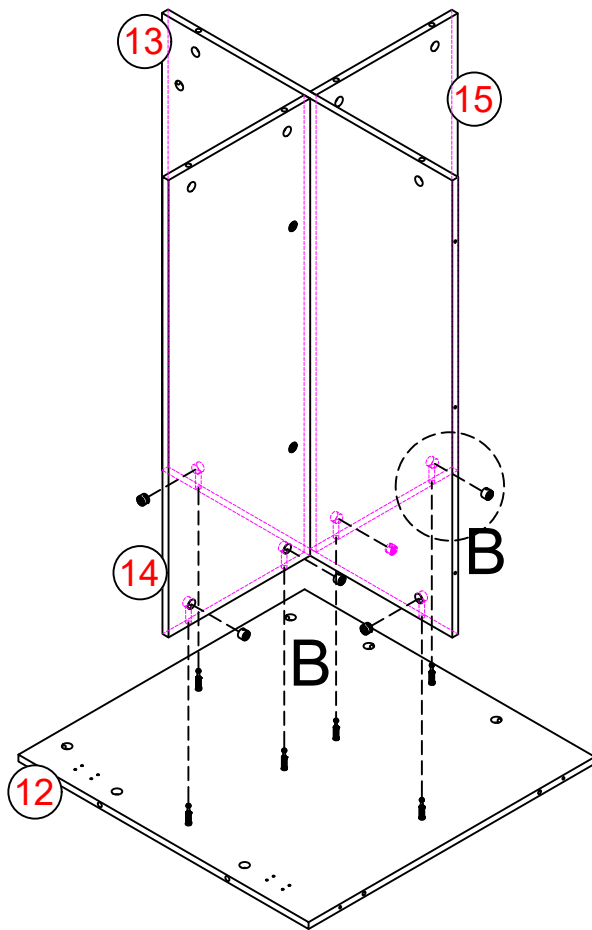

B



Ø15X10

6

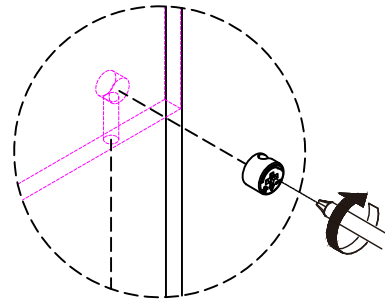

This step requires 2 people to install the hole together.

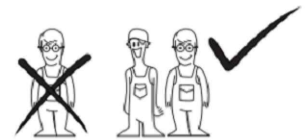

Step: 10

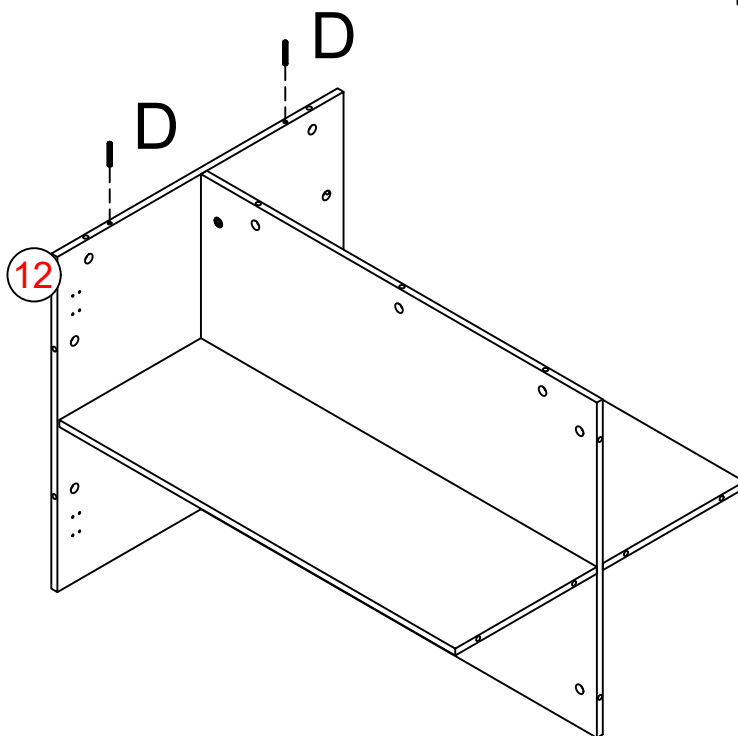

D



Ø6X40

2

Step: 11

G	 G1 G3 M3X14	2
---	---	---

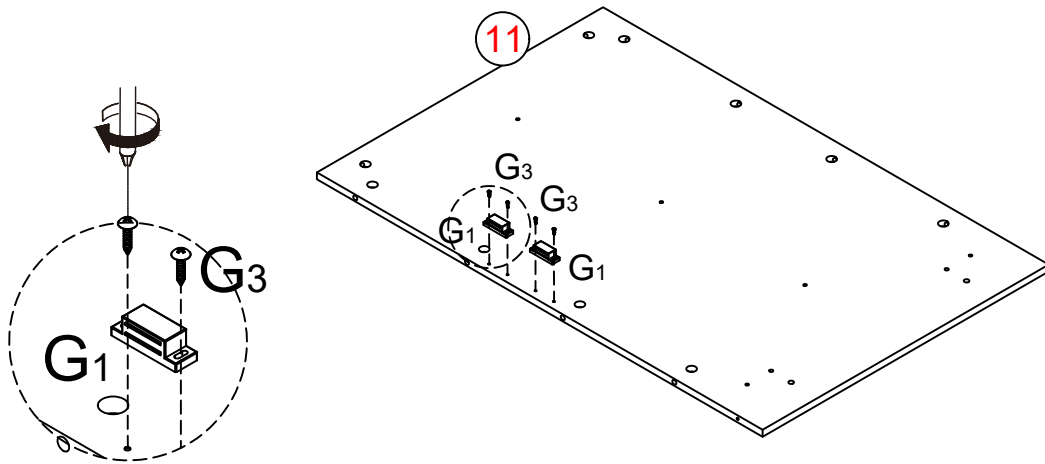

Step: 12

A	 M5X42	5
---	--	---

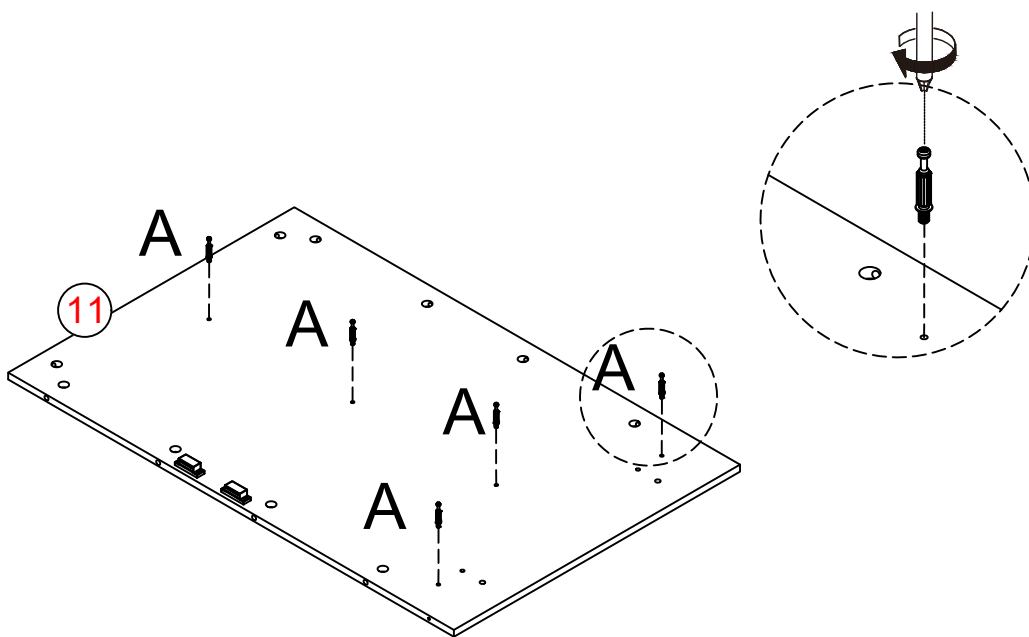

Step: 13

B



Ø15X10

5

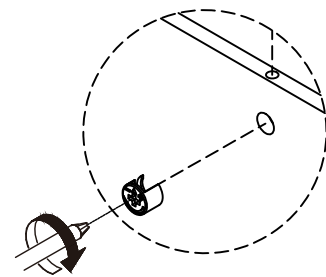
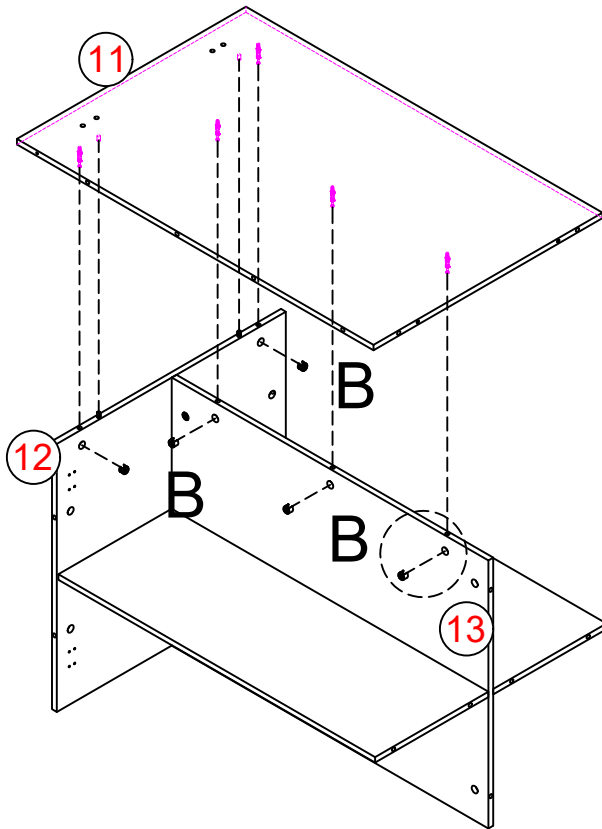

Step: 14

D



Ø6X40

2

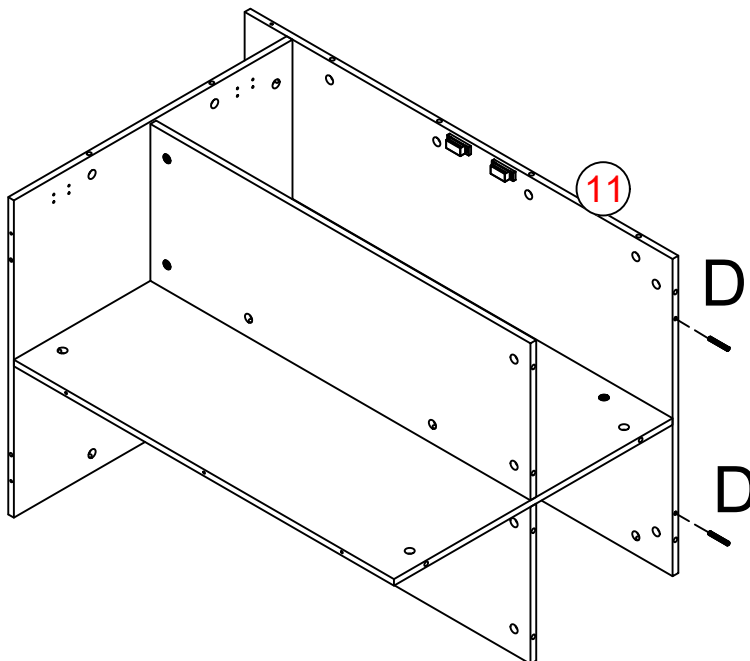

Step: 15

B



7

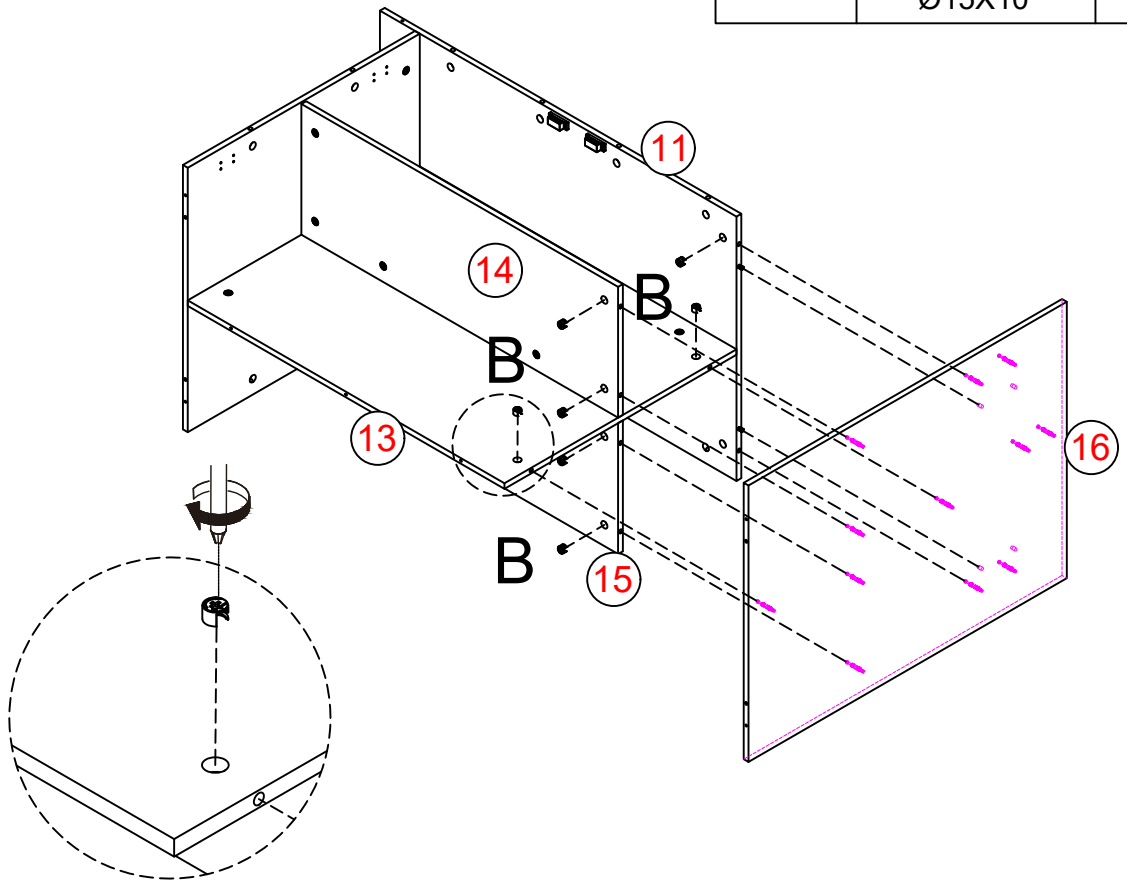

Step: 16

D

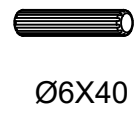

4

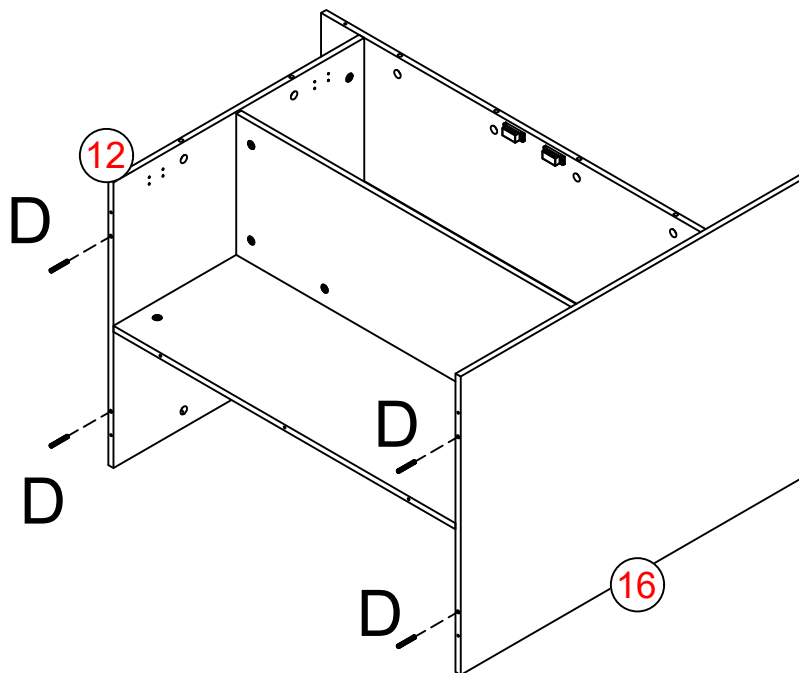

Step: 17

C



7

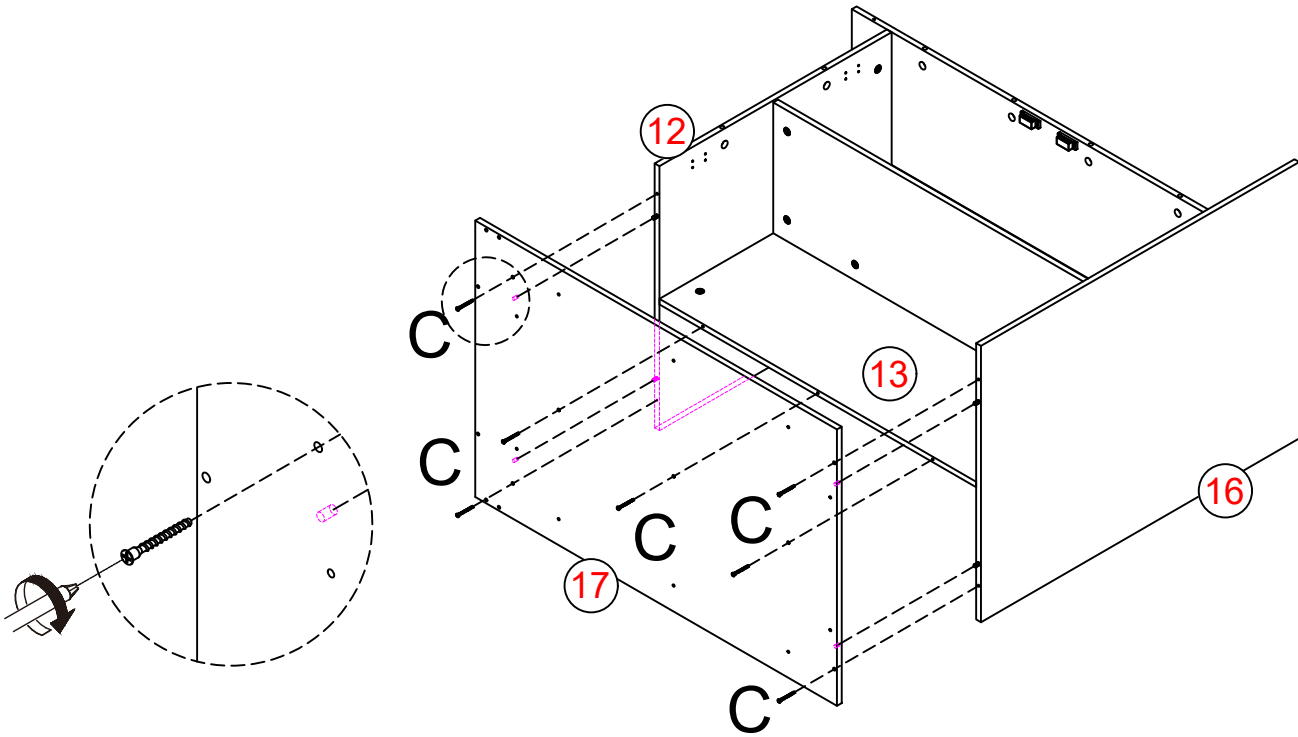

Step: 18

A

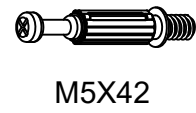

10

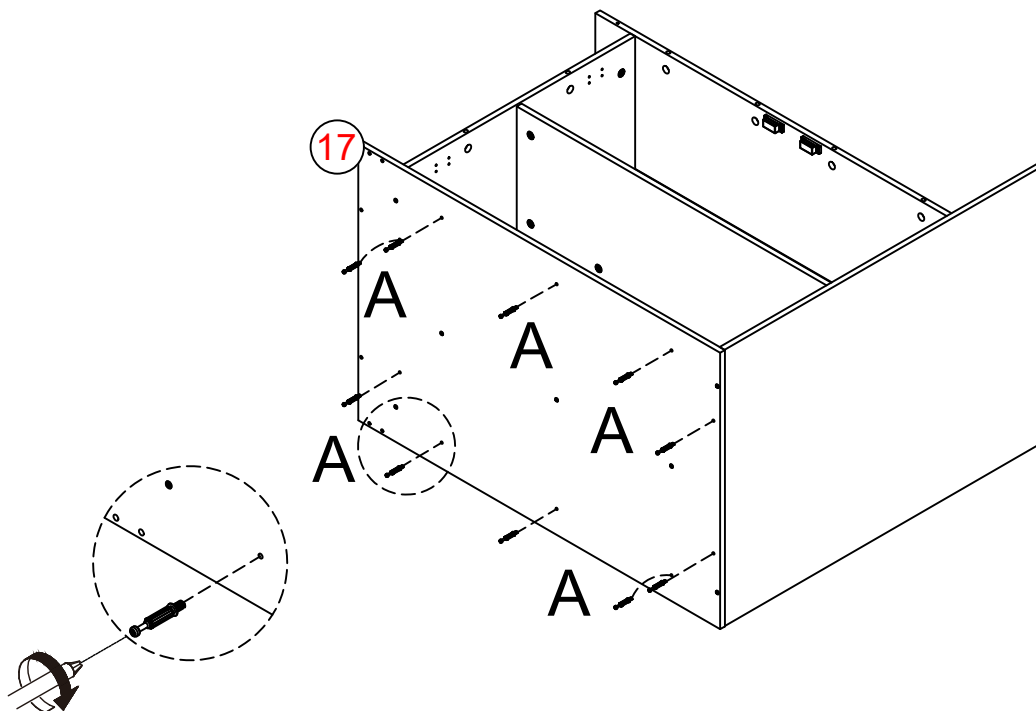

Step: 19

A



M5X42

4

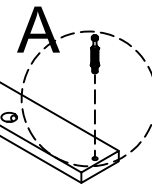
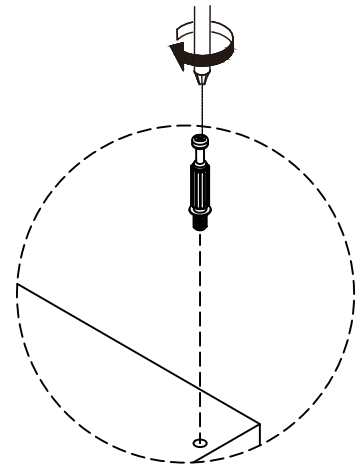
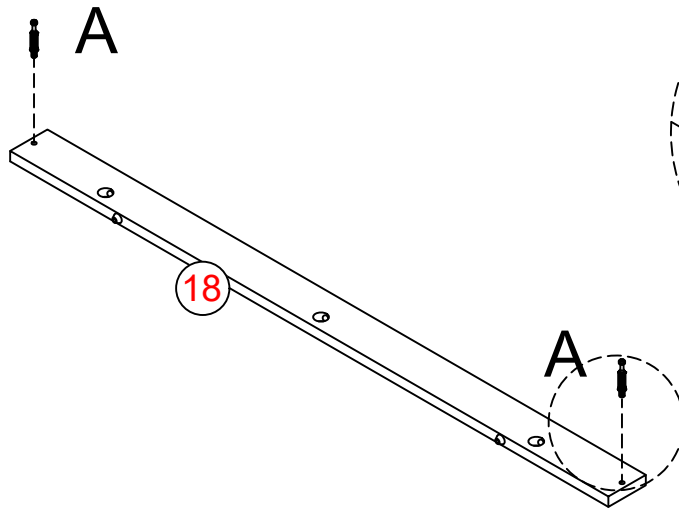

X 2

Step: 20

B



Ø15X10

4

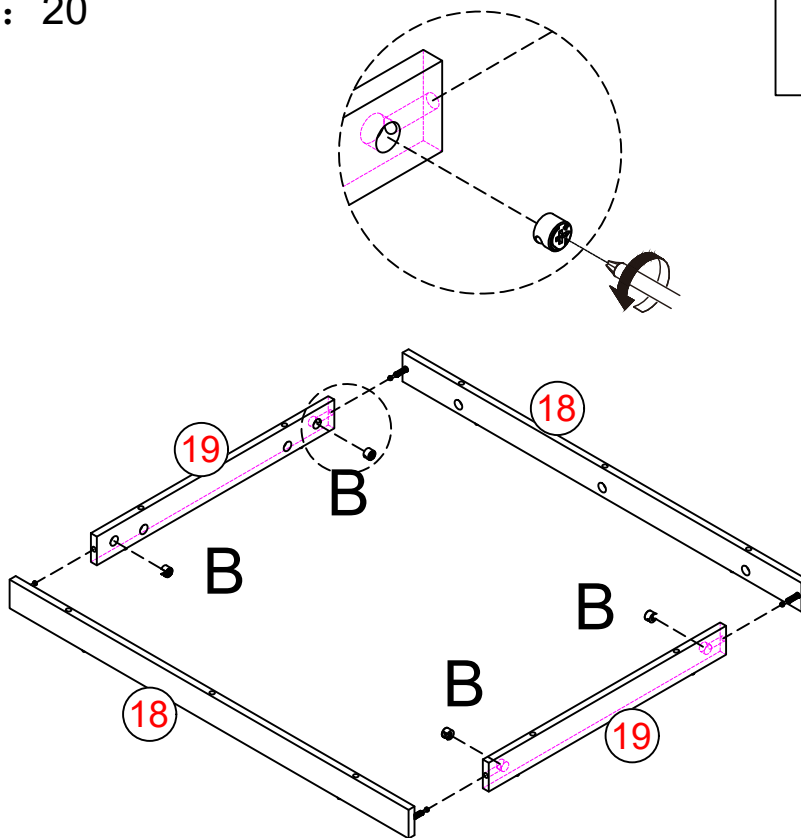

Step: 21

B



10

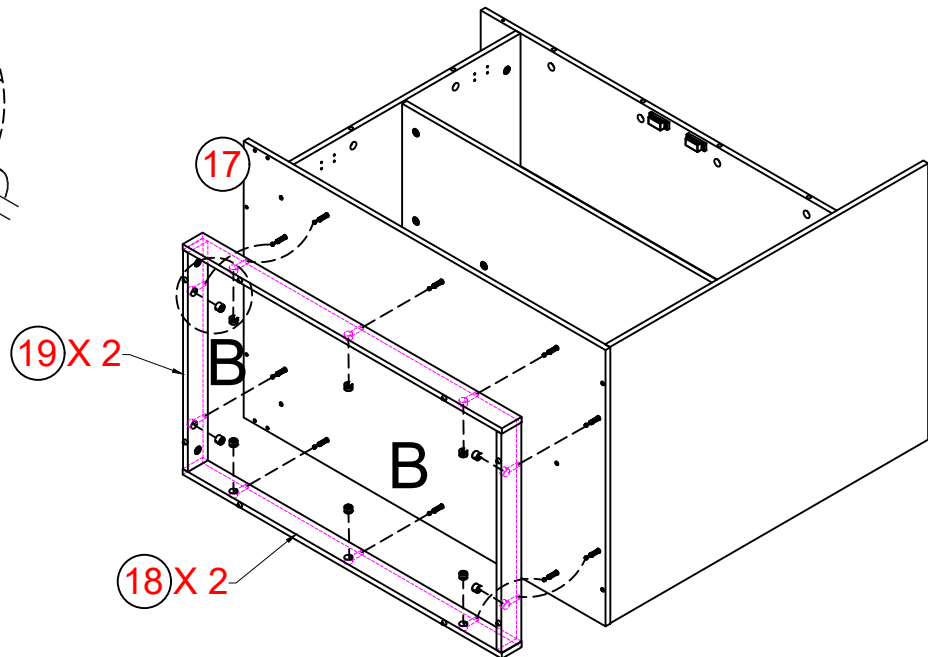
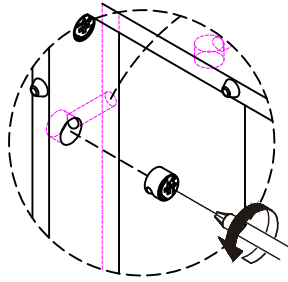

Step: 22

C



4

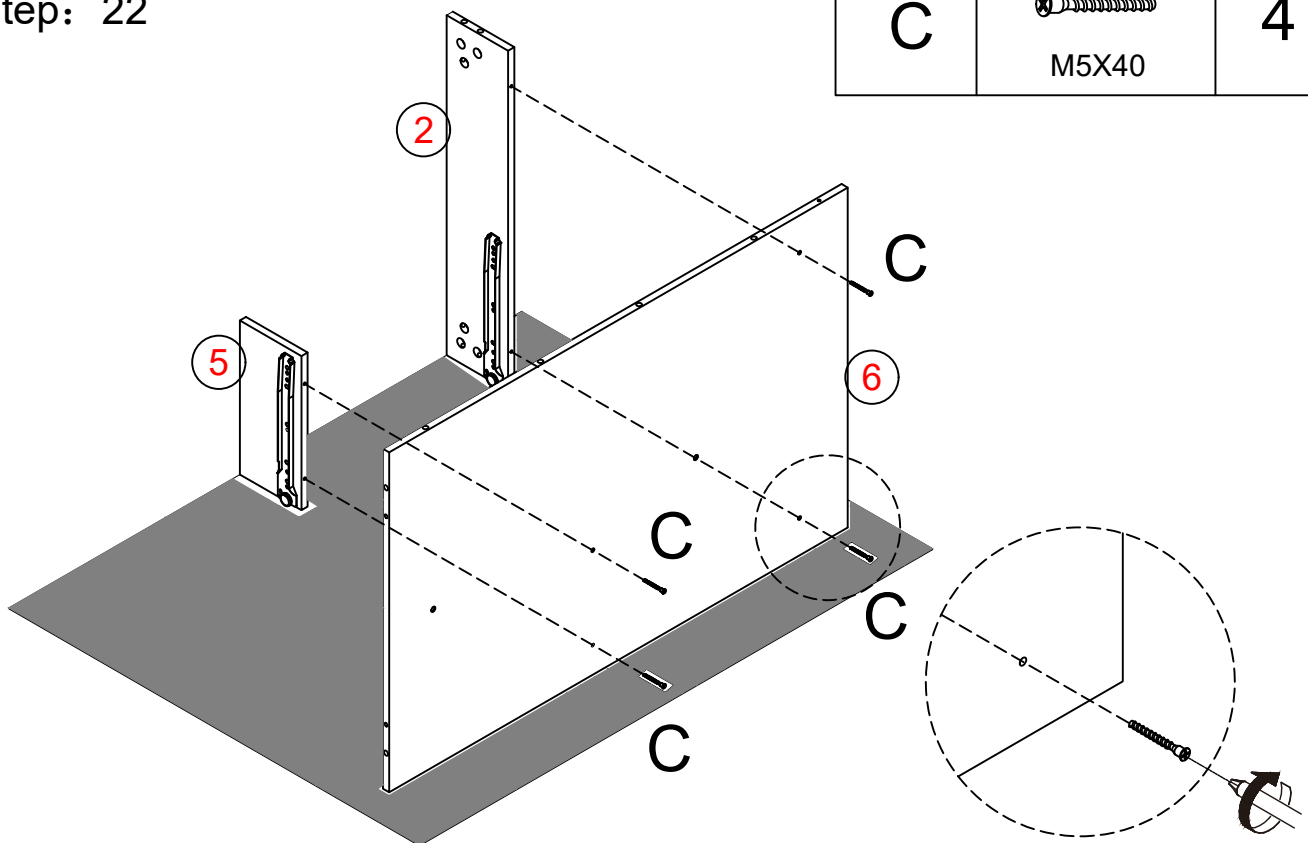

Step: 23

C



2

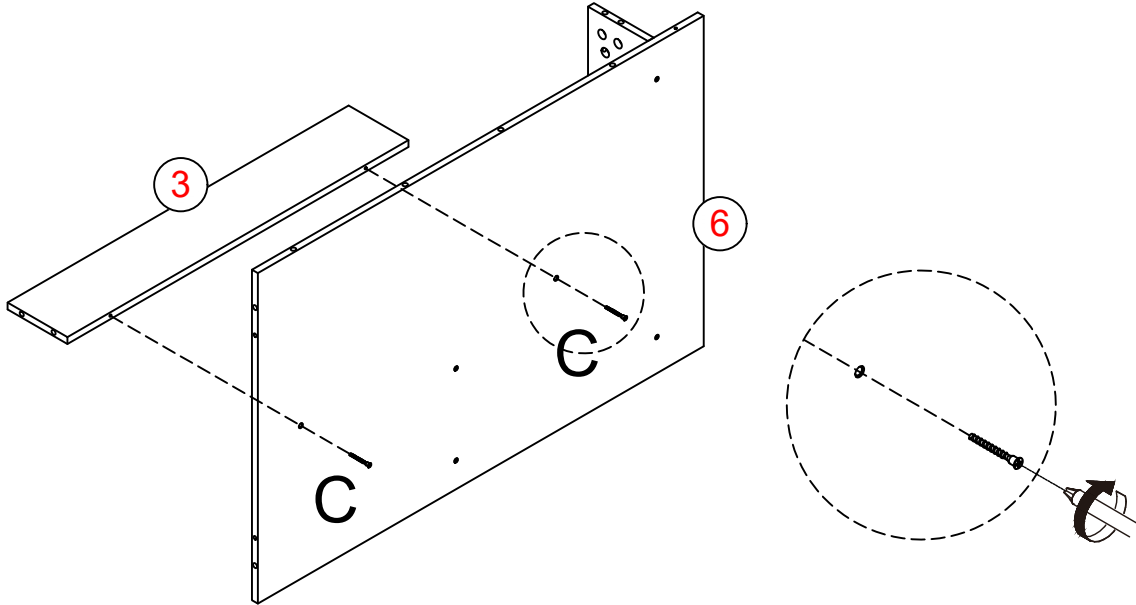

Step: 24

D

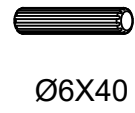

2

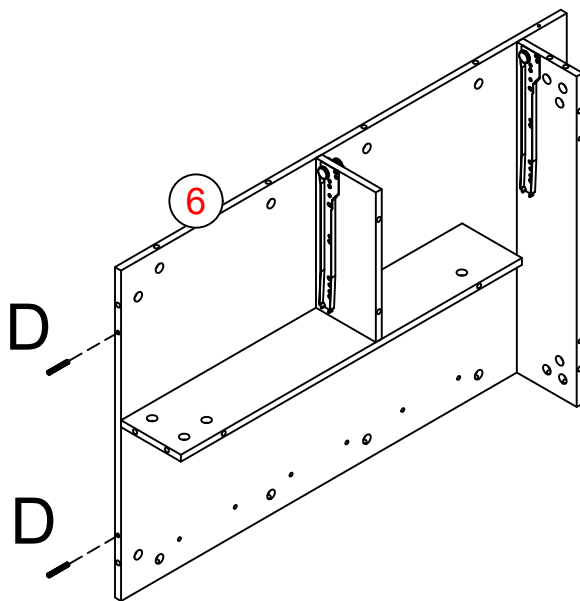

Step: 25

B



4

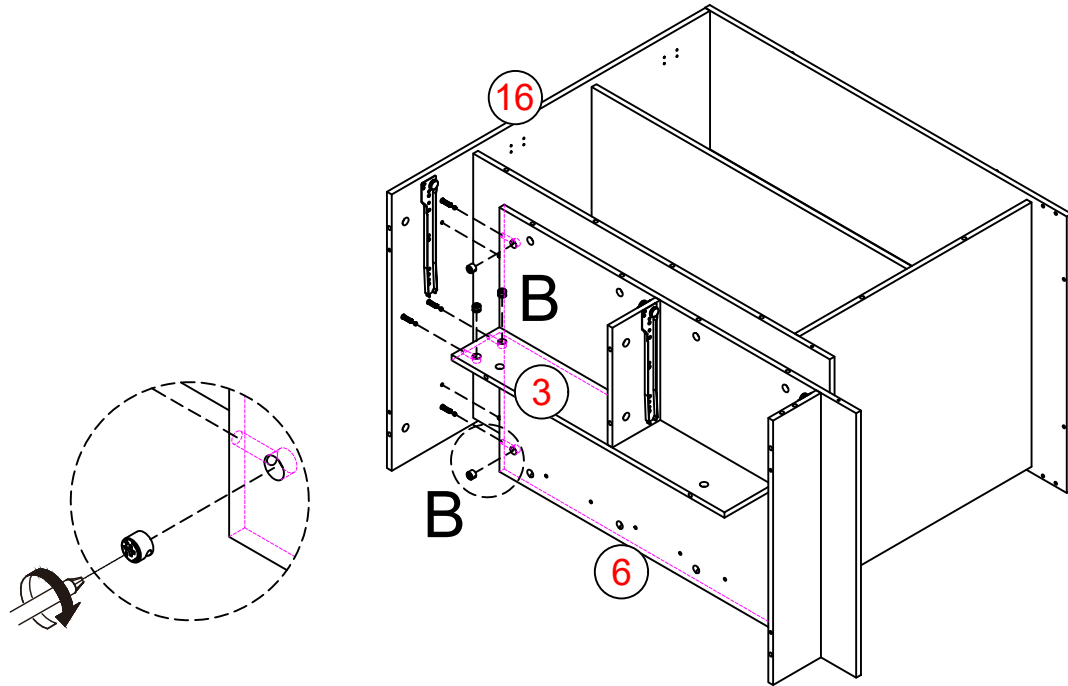

Step: 26

A

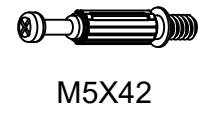

16

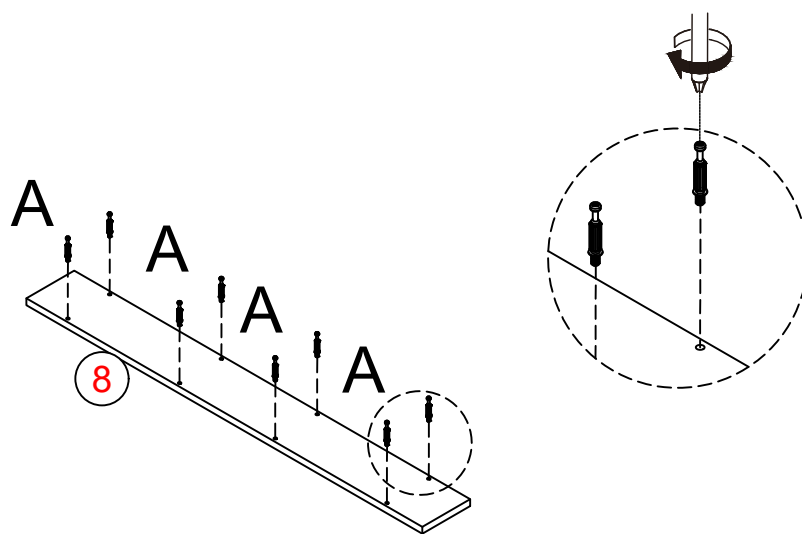

X 2

Step: 27

B



Ø15X10

8

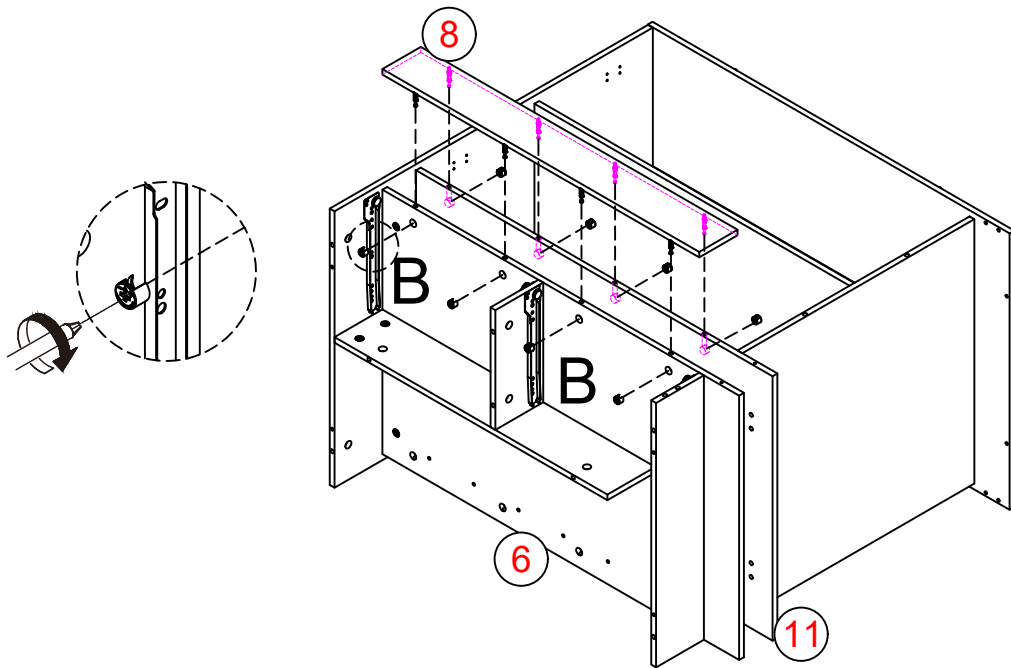

Step: 28

C



M5X40

2

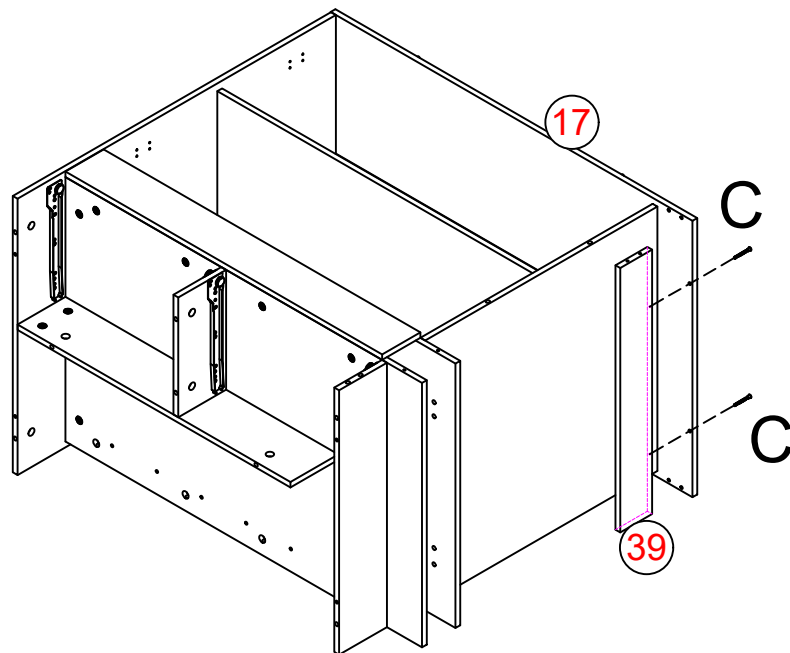

Step: 29

A



M5X42

8

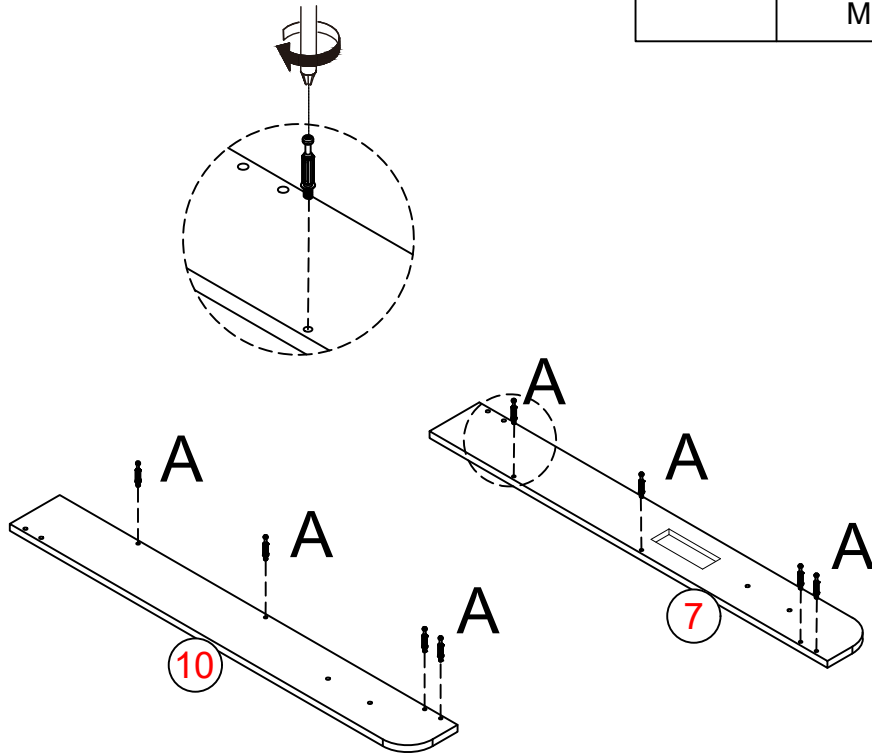

Step: 30

B



Ø15X10

4

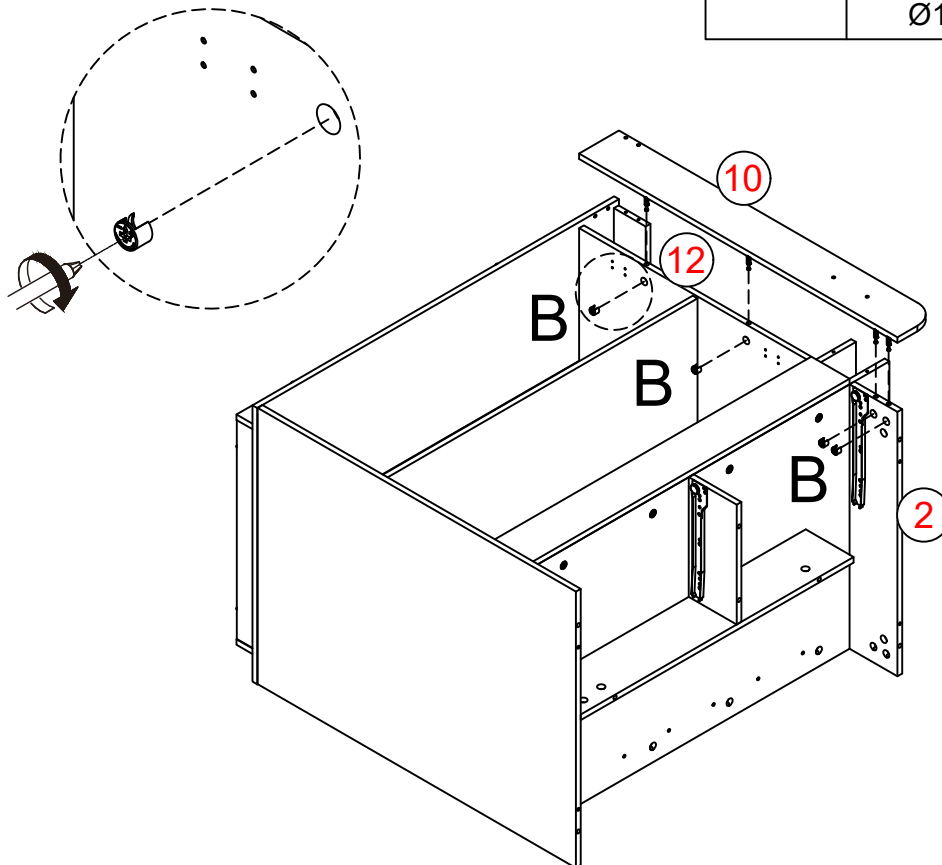

Step: 31

C



6

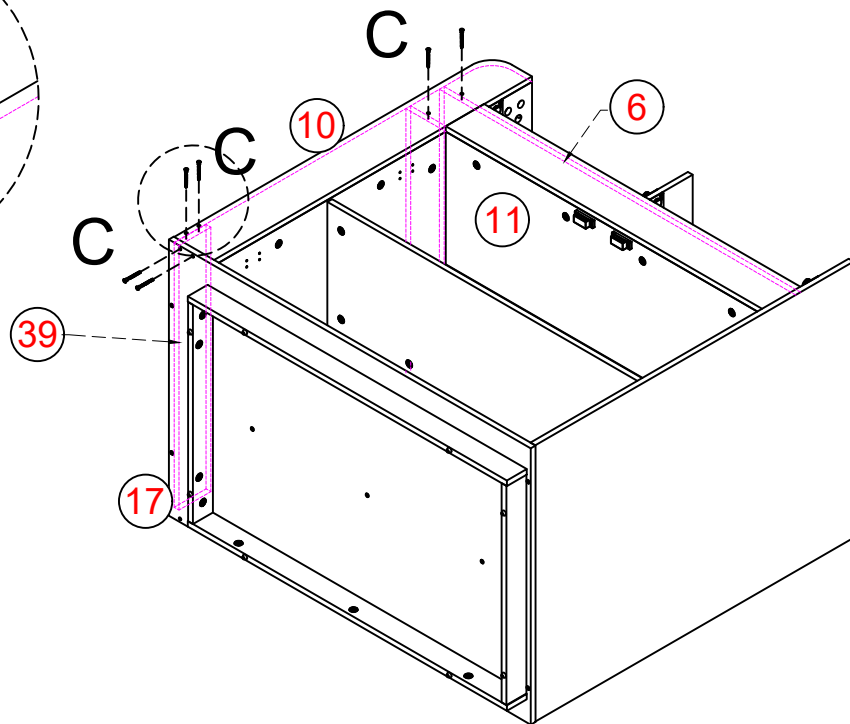
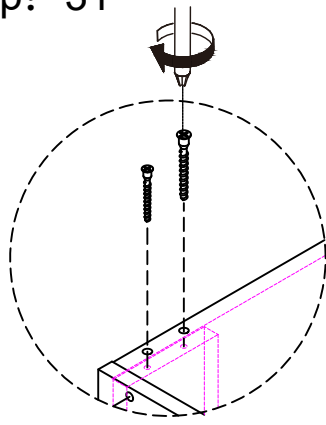

Step: 32

B



9

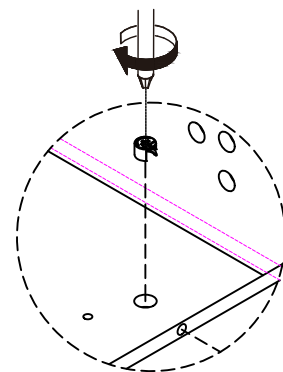
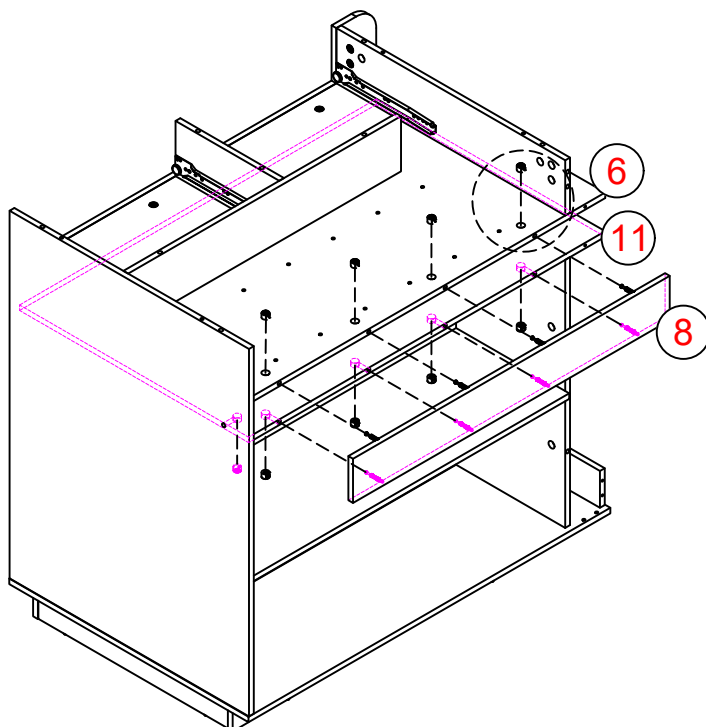

Step: 33

B



4

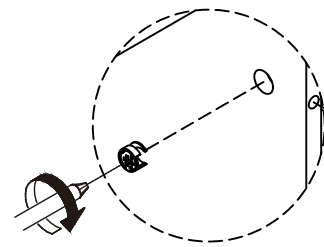
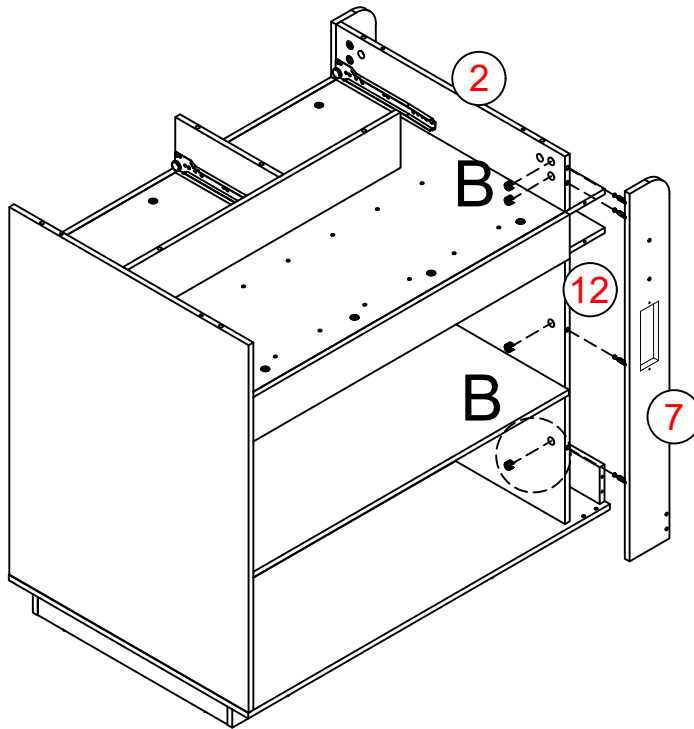

Step: 34

C



4

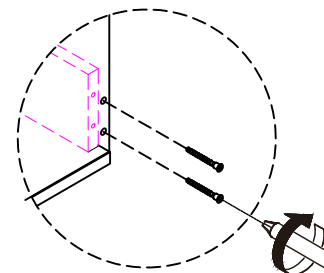
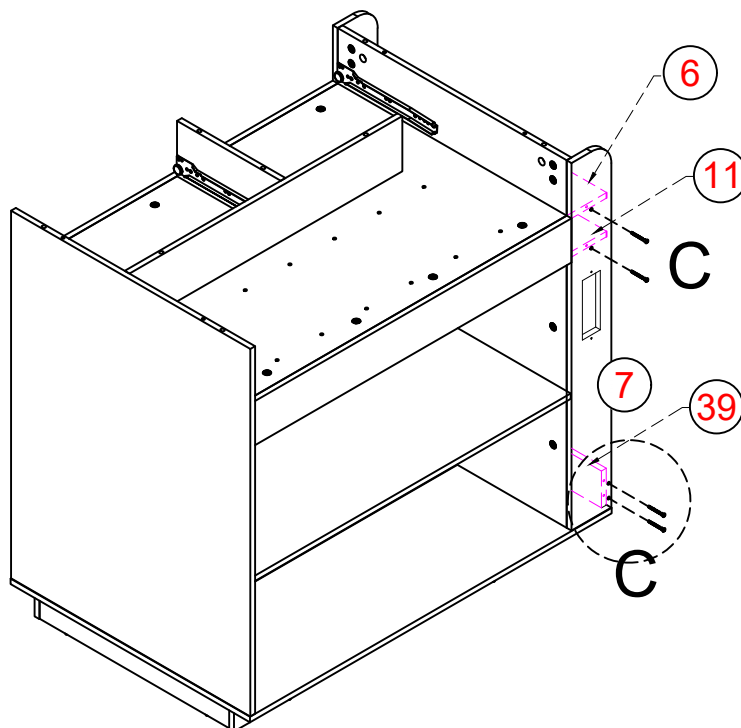

Step: 35

C



2

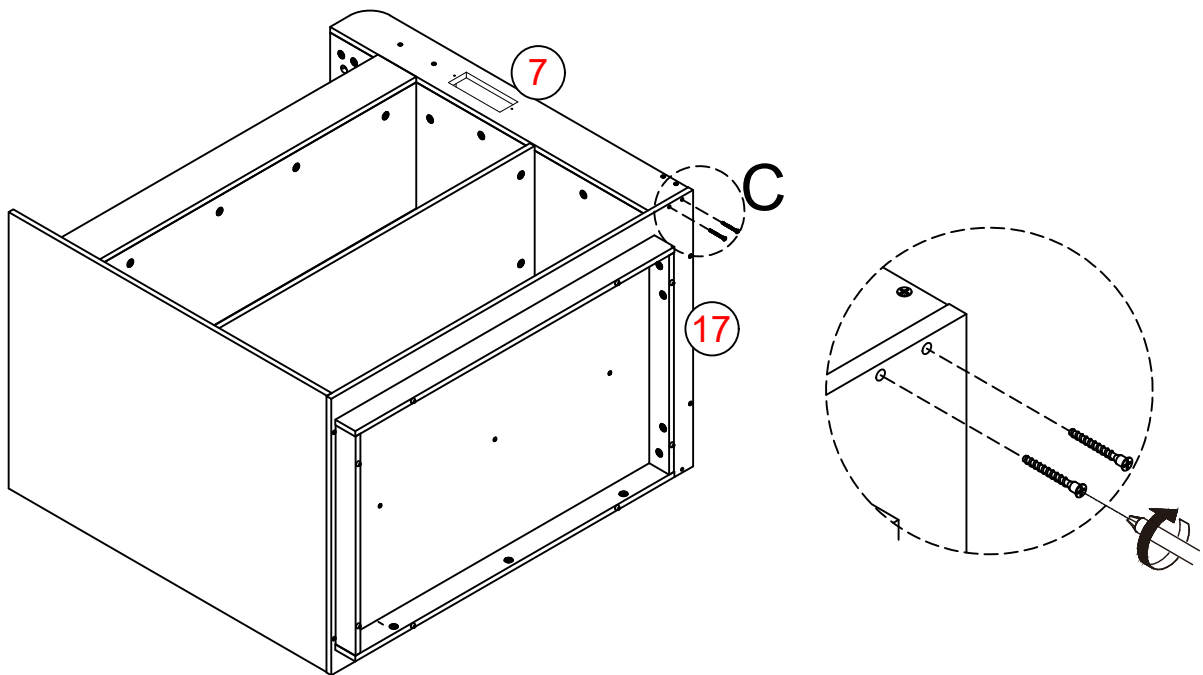

Step: 36

M



20

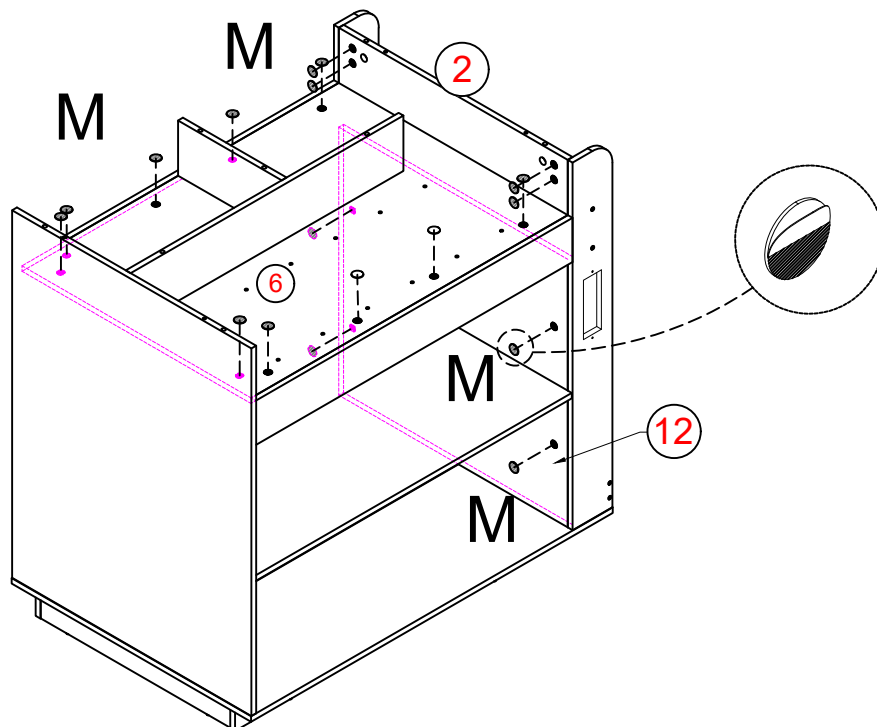

Step: 37

D



Ø6X40

24

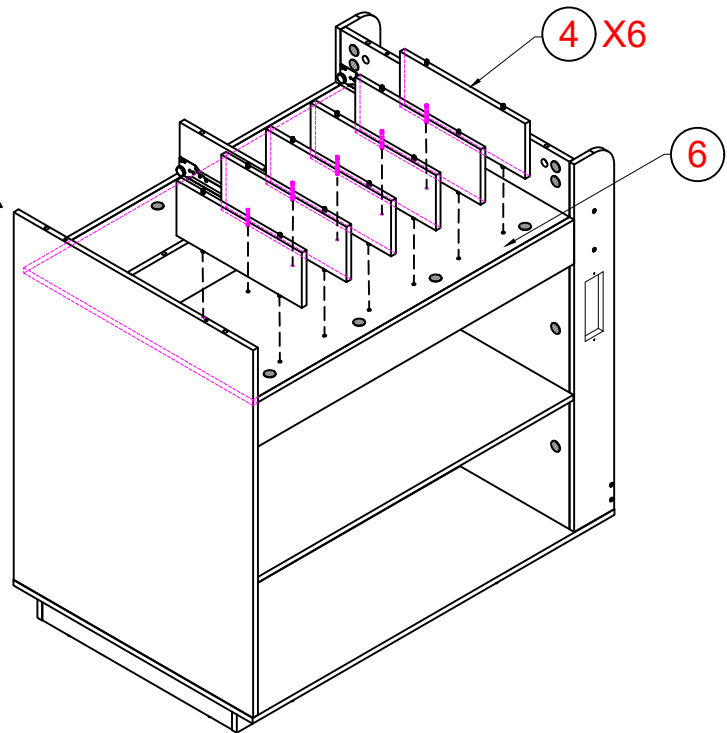
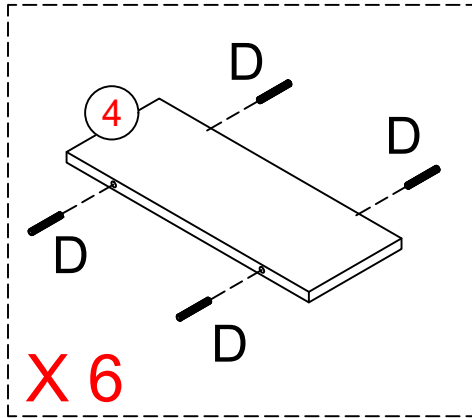

Step: 38

D



Ø6X40

4

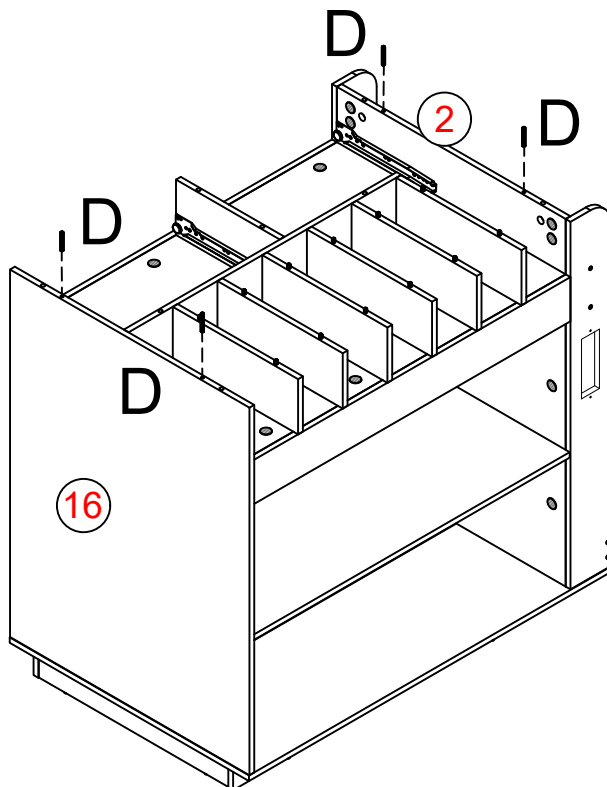

Step: 39

A



M5X42

8

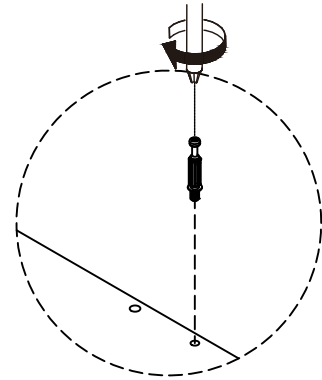
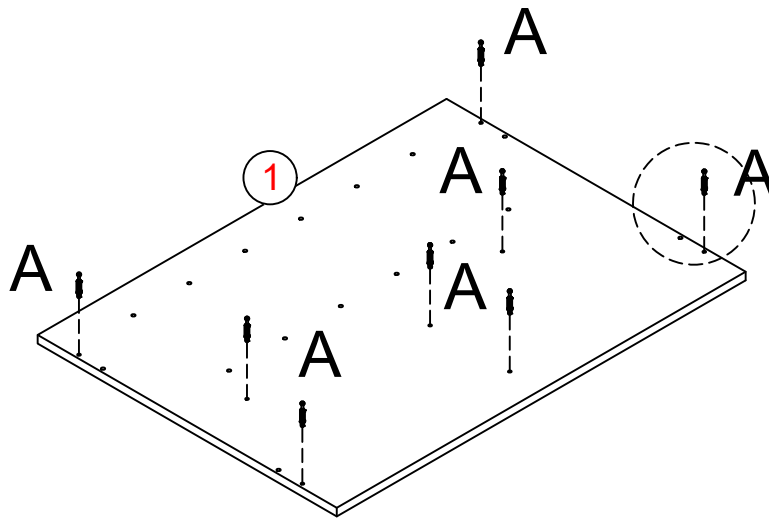

Step: 40

B



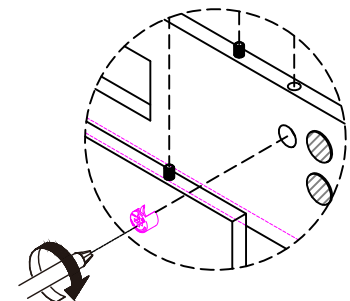
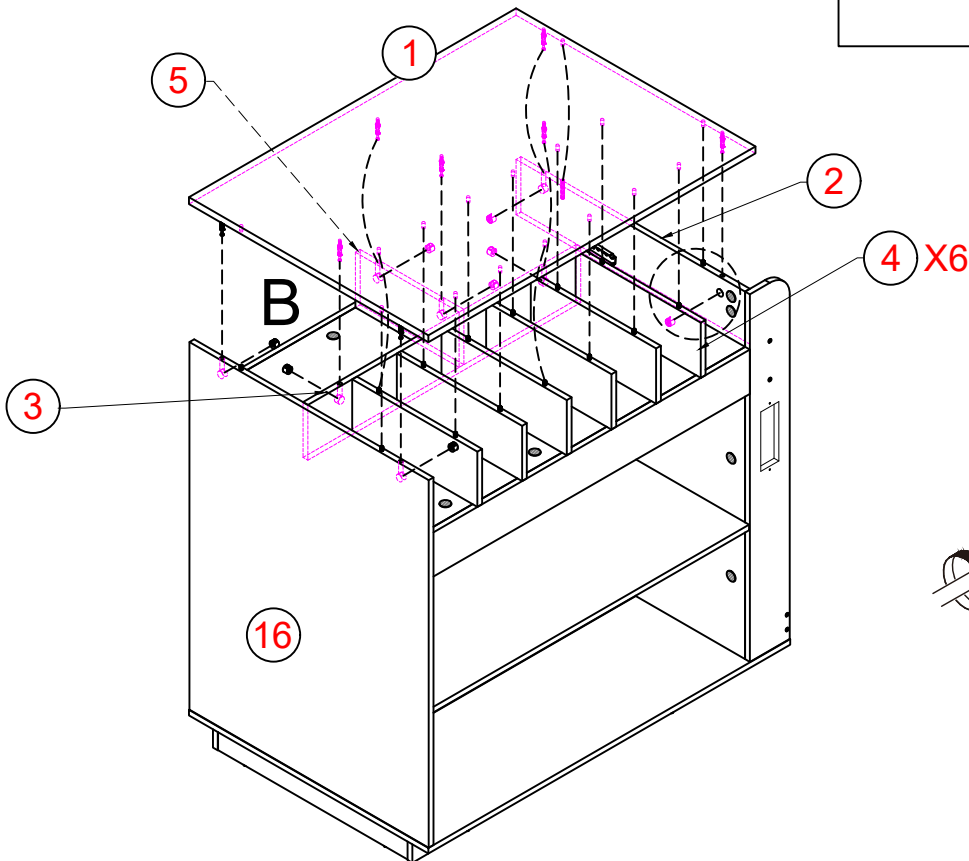

Ø15X10

8

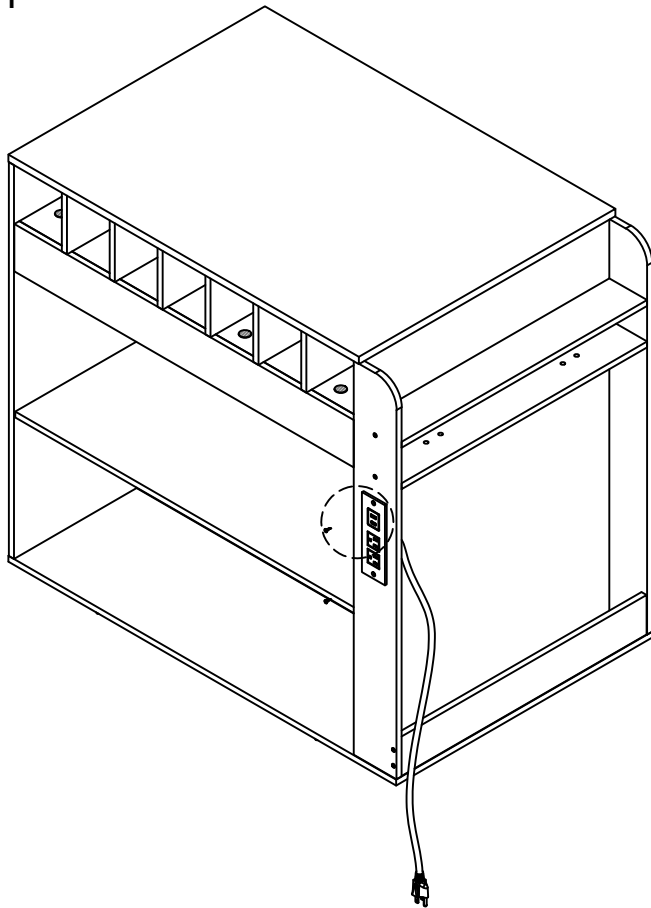

Step: 41



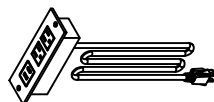

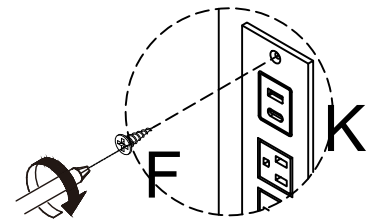
F	 M3.5X12	2
K		1

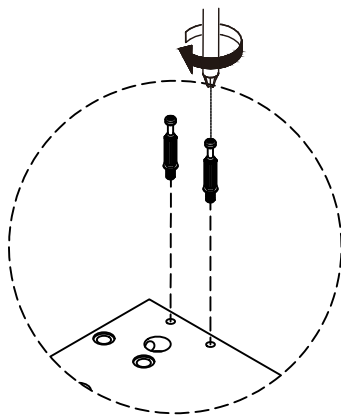

7

Step: 42



A	 M5X42	4
---	--	---

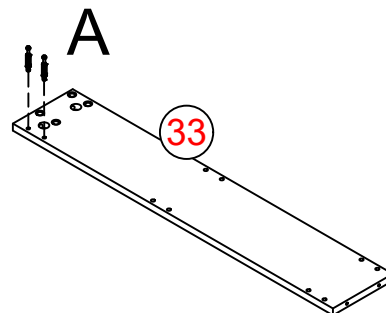
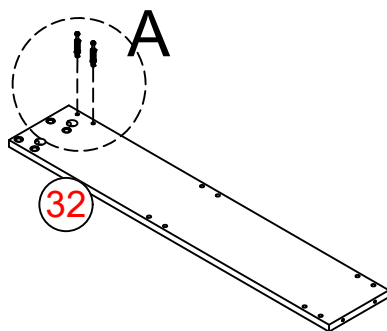

Step: 43

C



4

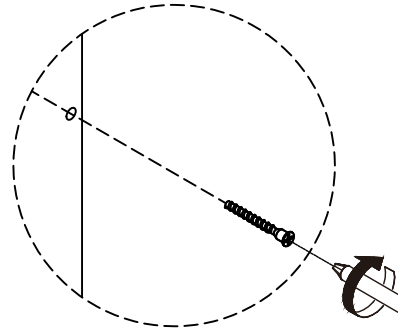
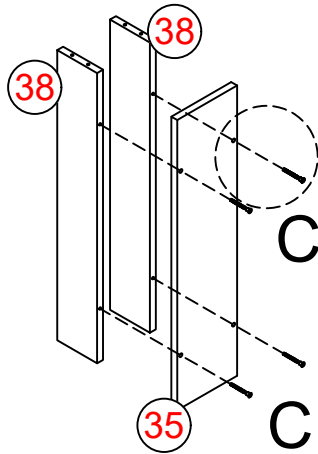

Step: 44

C



8

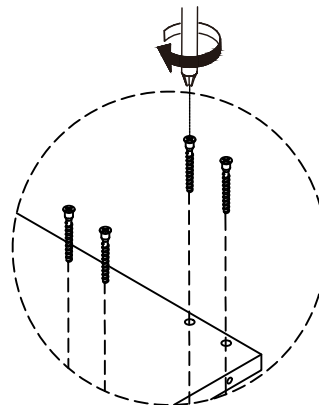
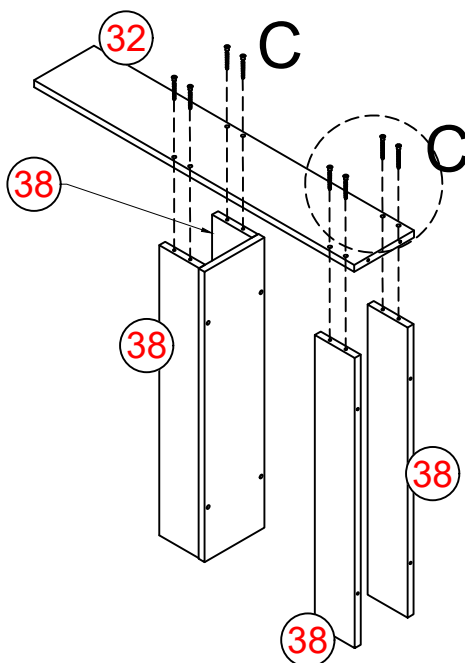

Step: 45

B



Ø15X10

2

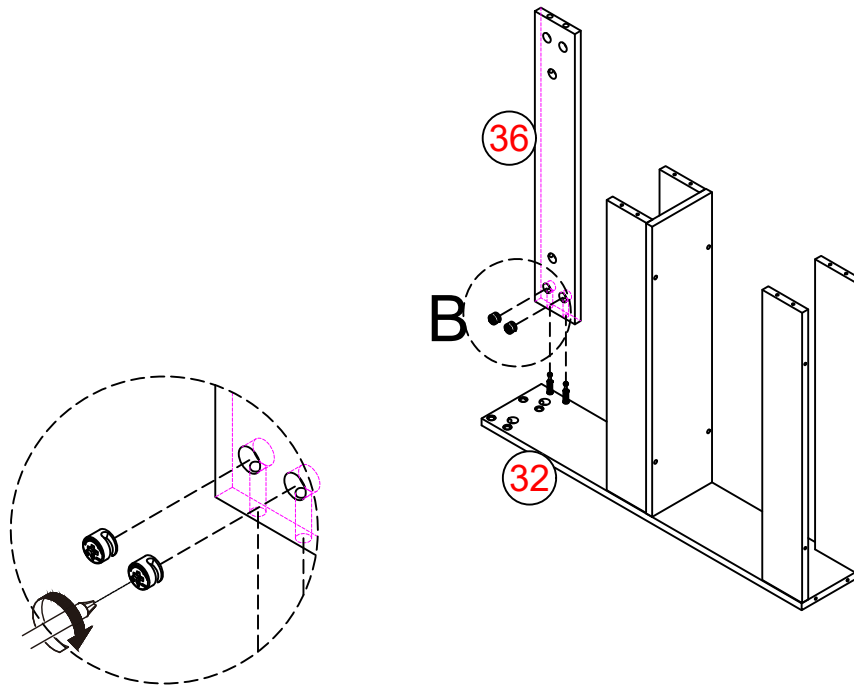

Step: 46

B



Ø15X10

2

C

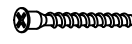

M5X40

8

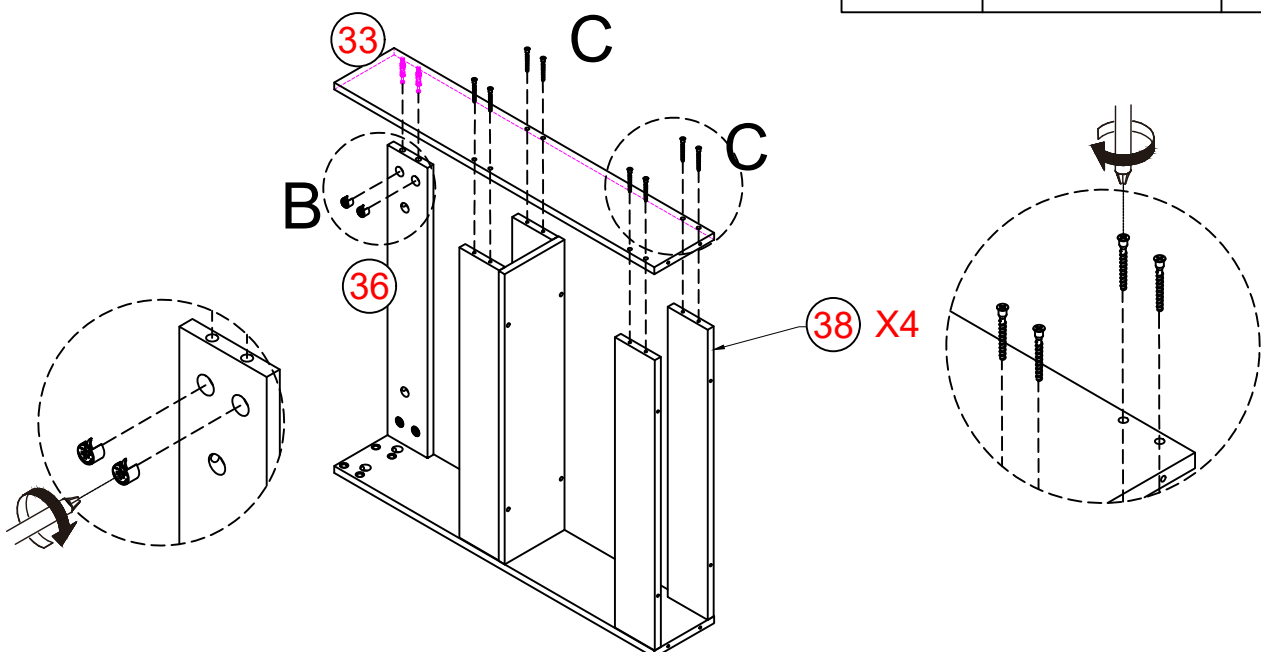

Step: 47

C



8

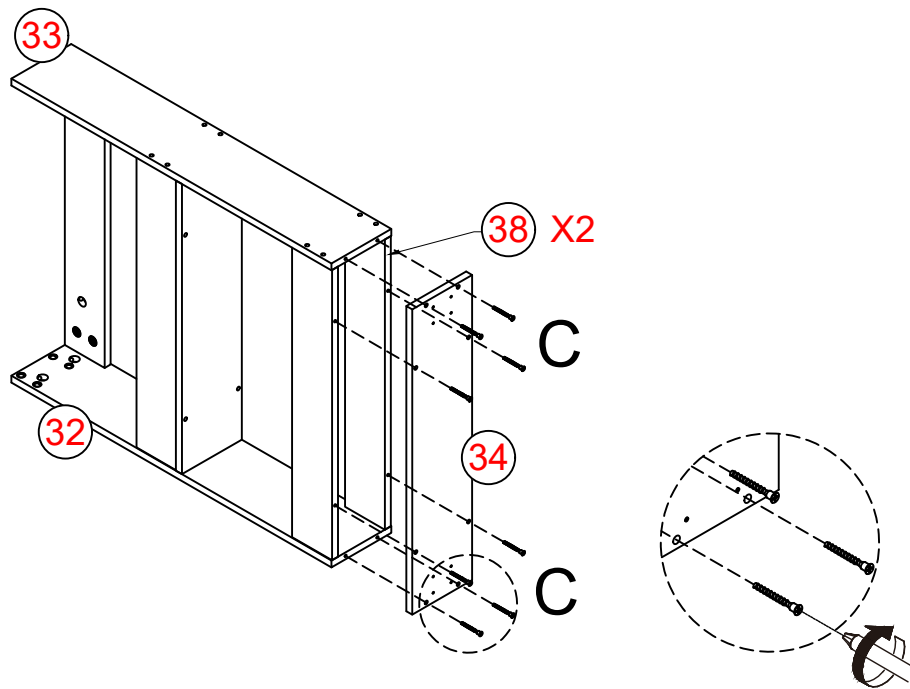

Step: 48

A

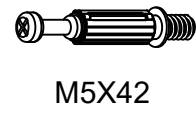

14

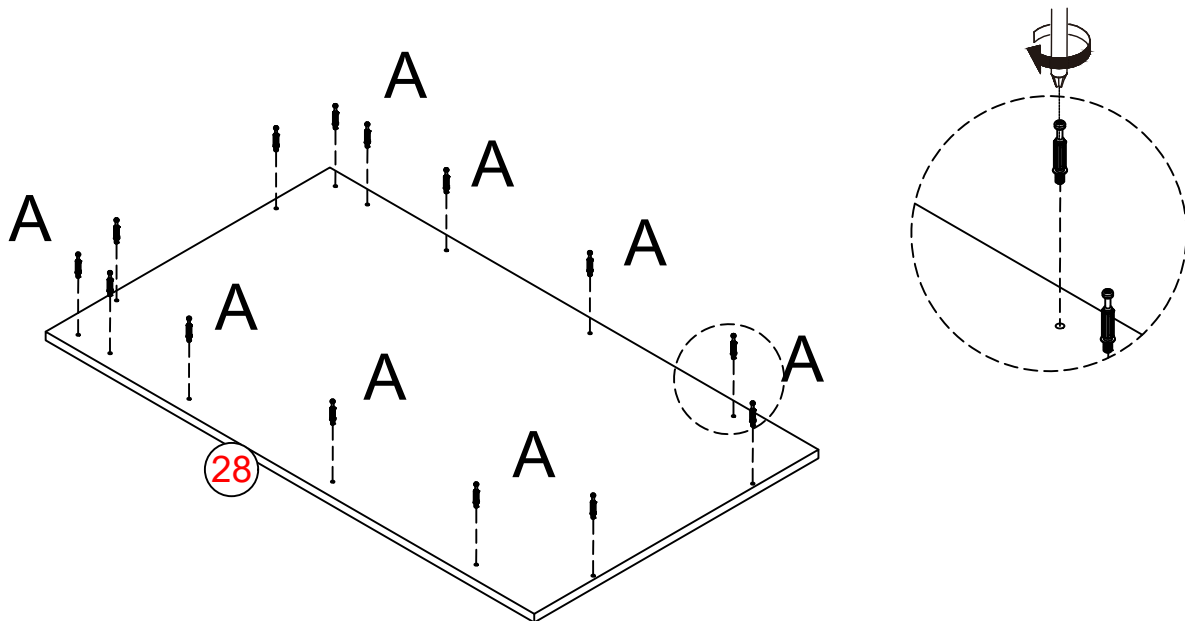

Step: 49

B



6

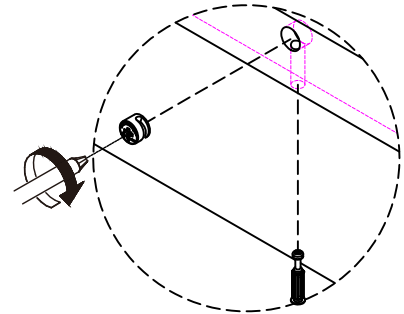
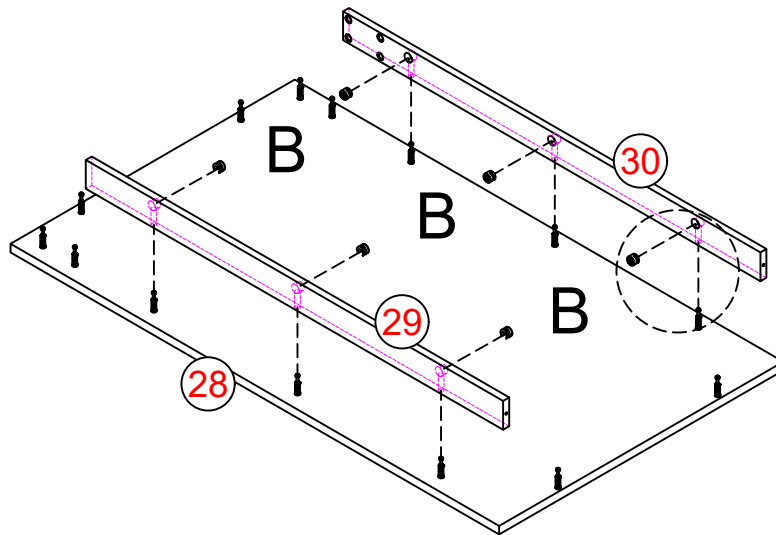

Step: 50

B



2

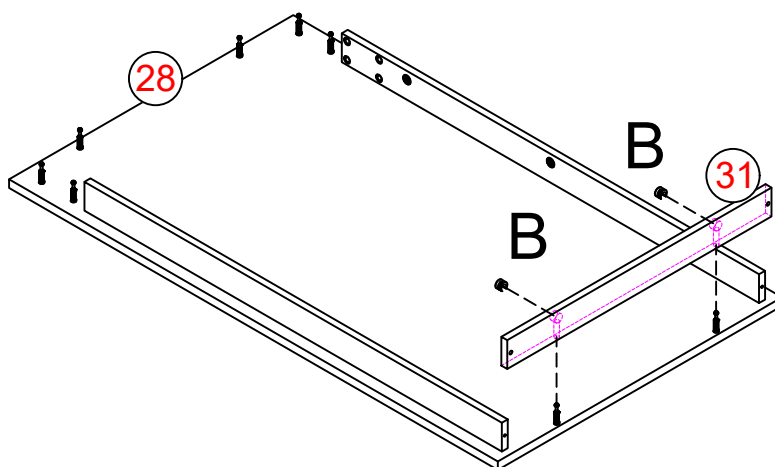

Step: 51

C



2

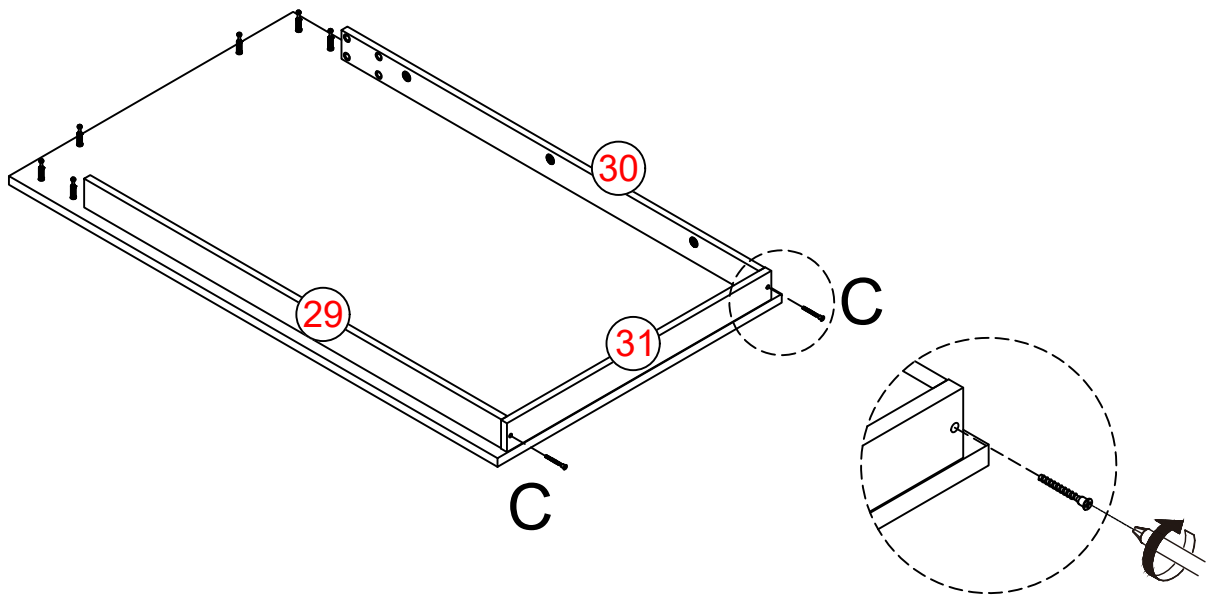

Step: 52

B



6

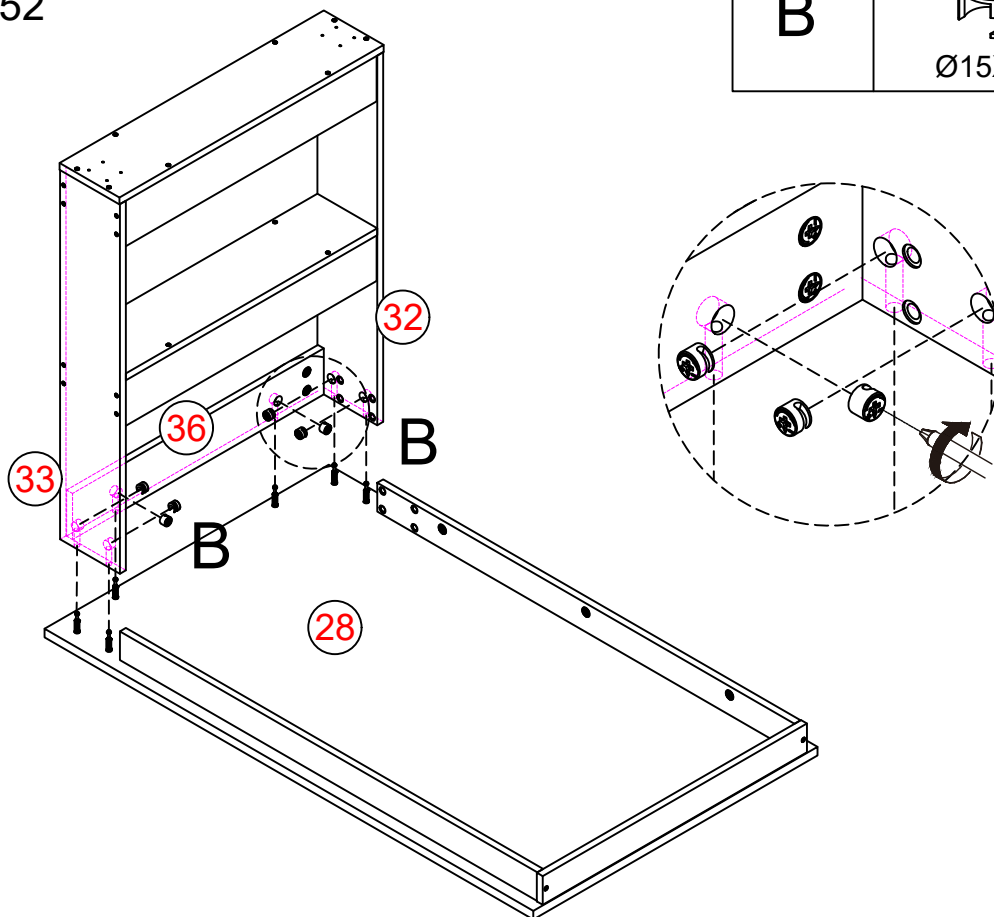

Step: 53

E



16

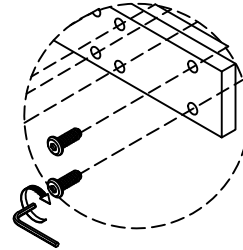
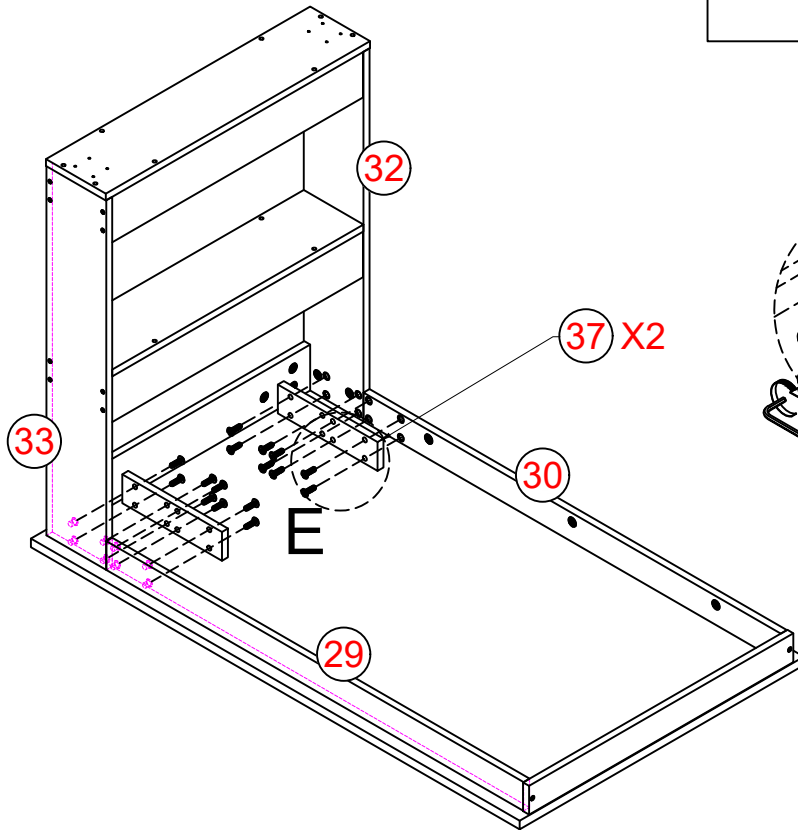

Step: 54

N



2

O



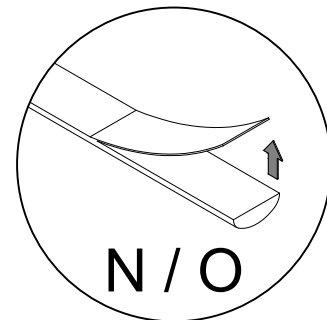
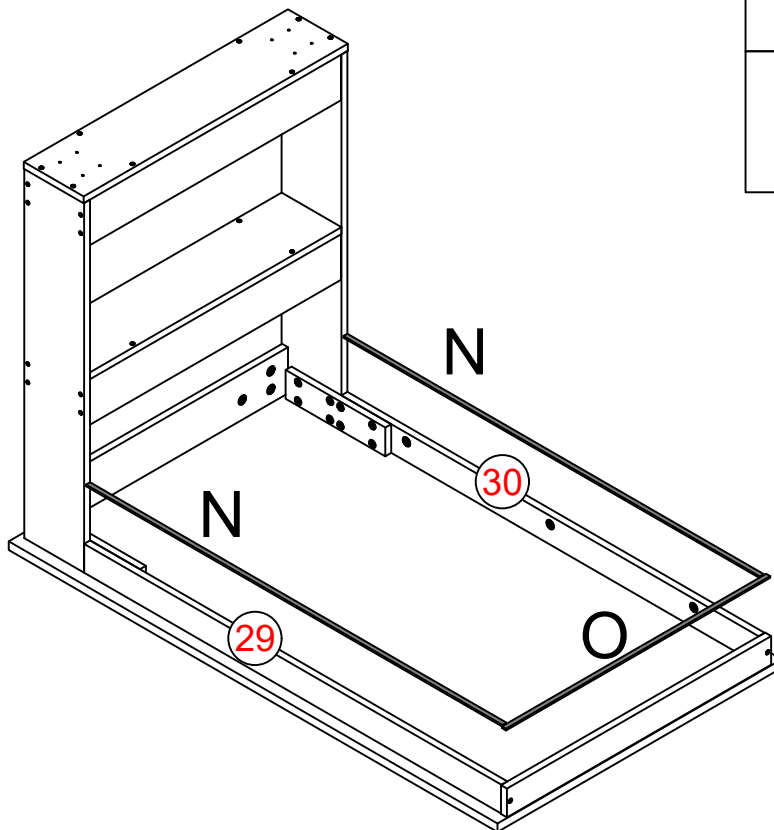

1

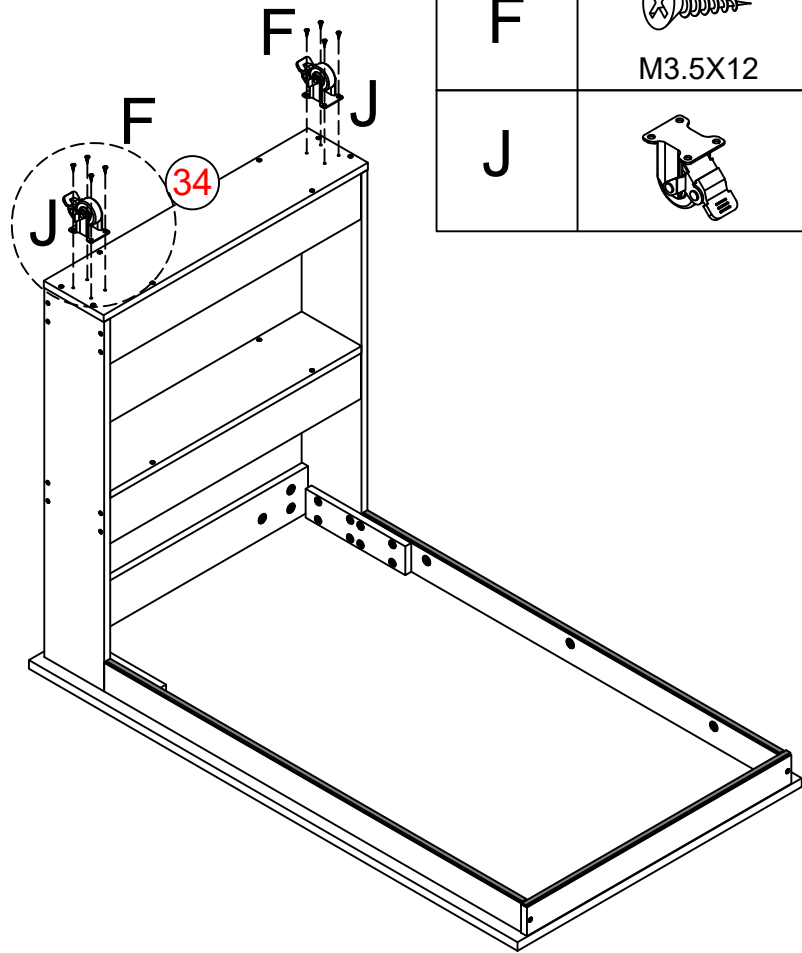
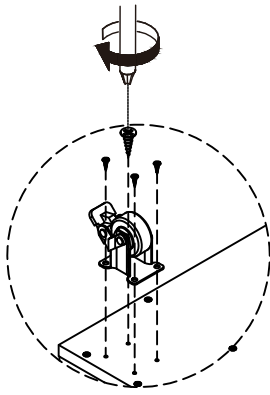

Step: 55



F	 M3.5X12	8
J		2

Step: 56

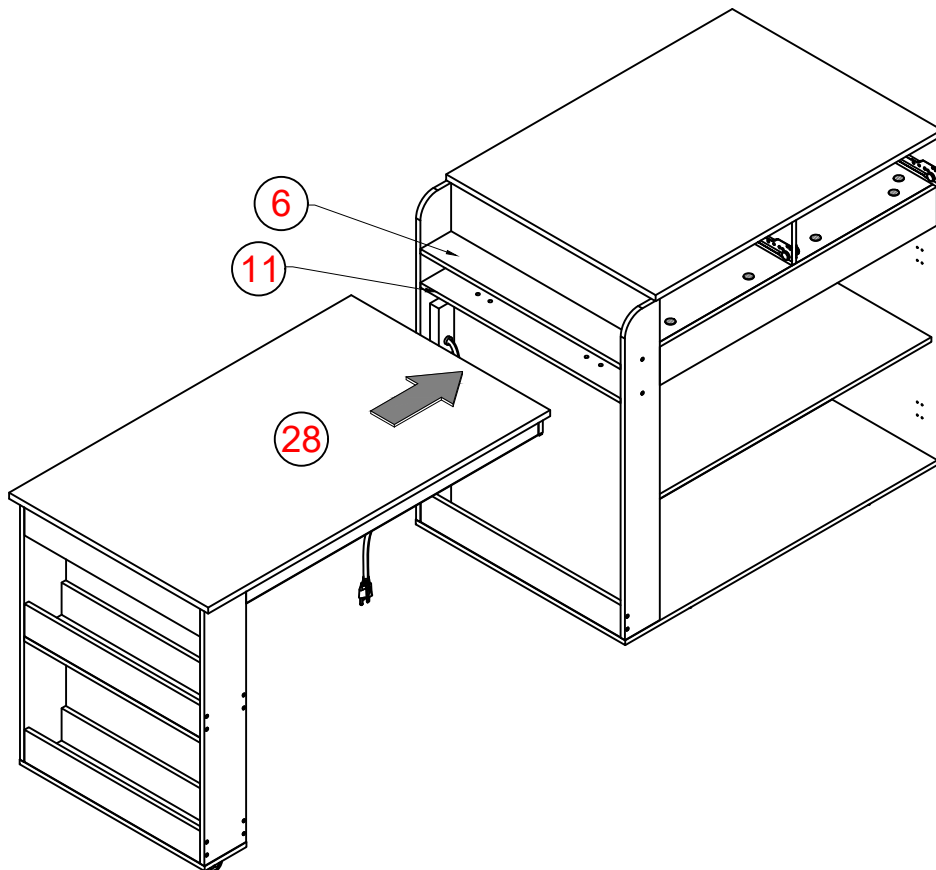

Step: 57

S



Ø6X20

2

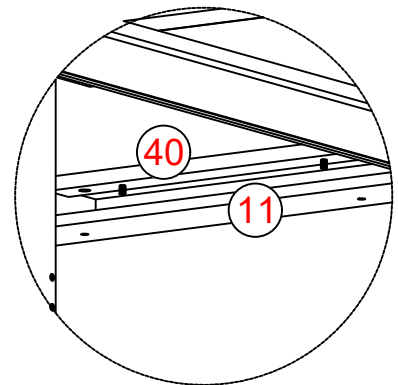
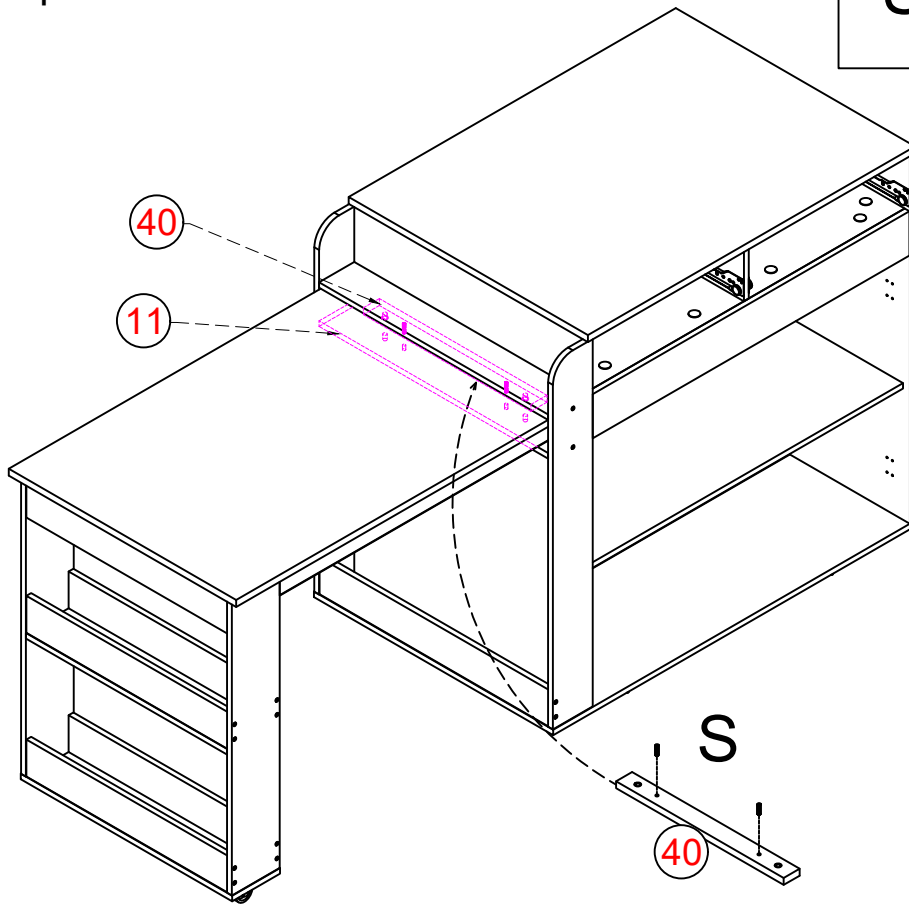

Step: 58

E



M6X20

2

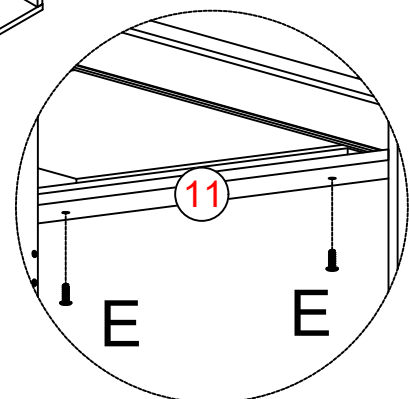
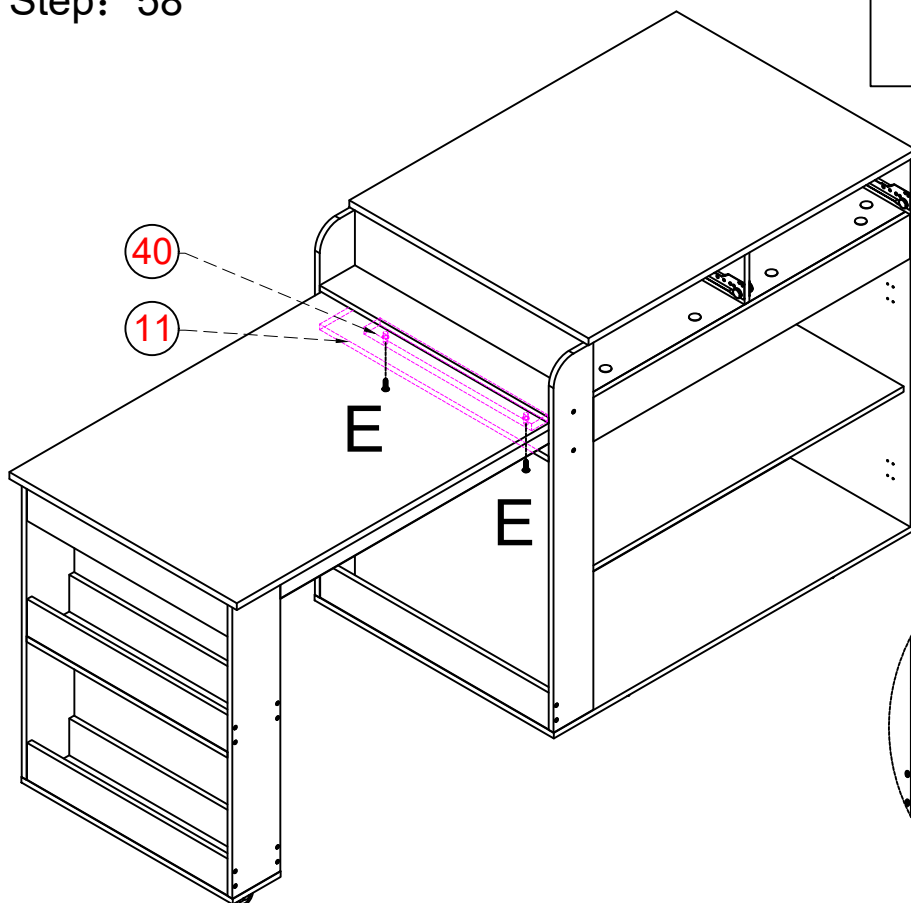

Step: 59

A



M5X42

8

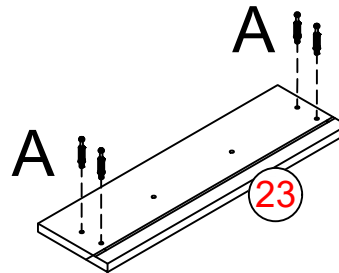
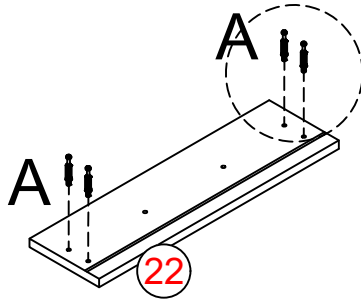
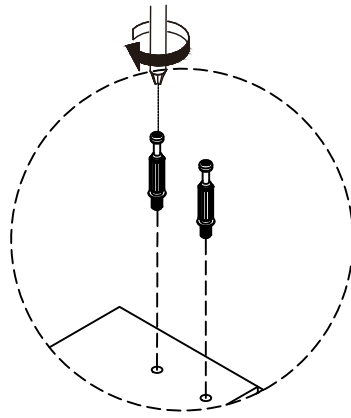

Step: 60

C



M5X40

8

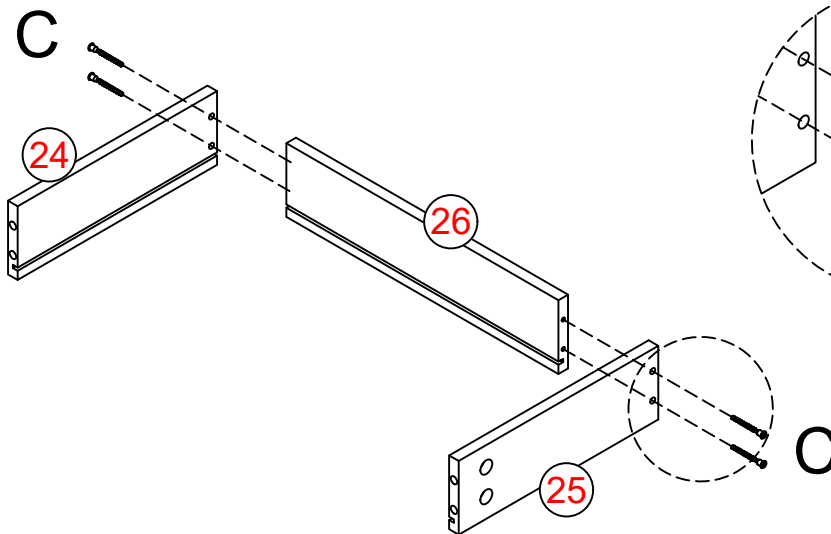

X 2

Step: 61

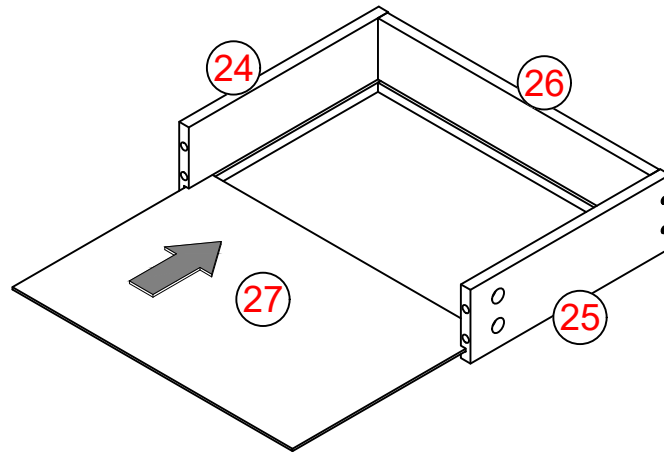

X 2

Step: 62

B



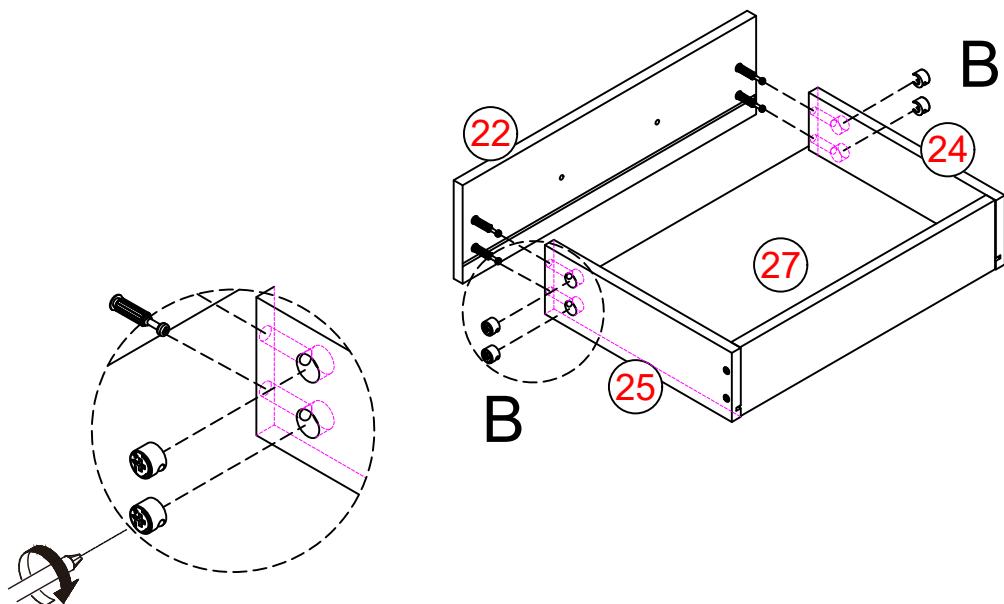

Ø15X10

4

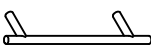

Step: 63

H		1
P	 M4X 22	2

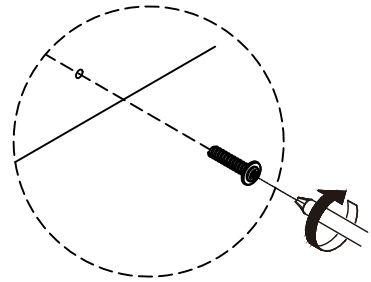
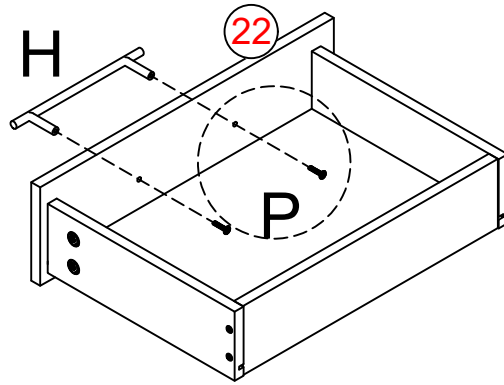

Step: 64

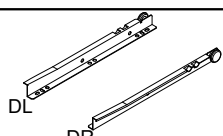
F	 M3.5X12	4
L		2

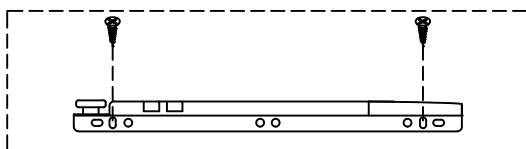
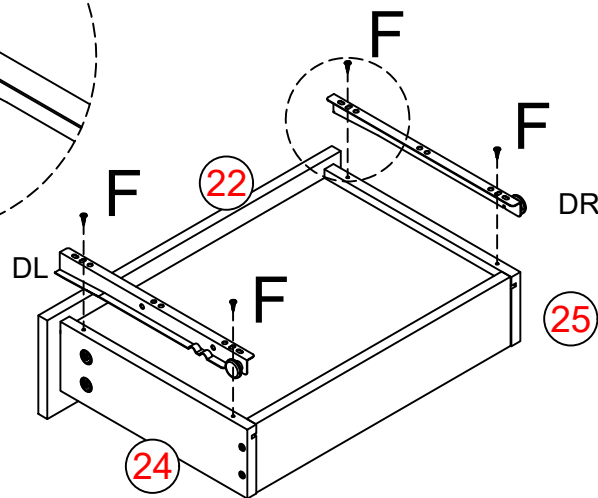
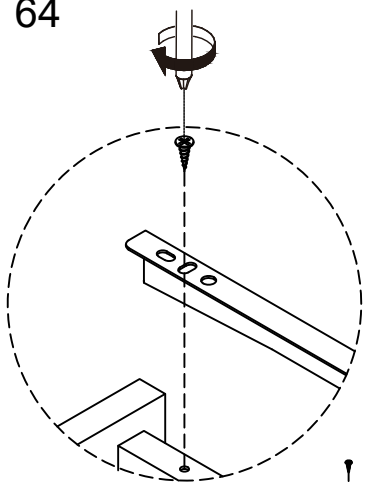

Step: 65

B



Ø15X10

4

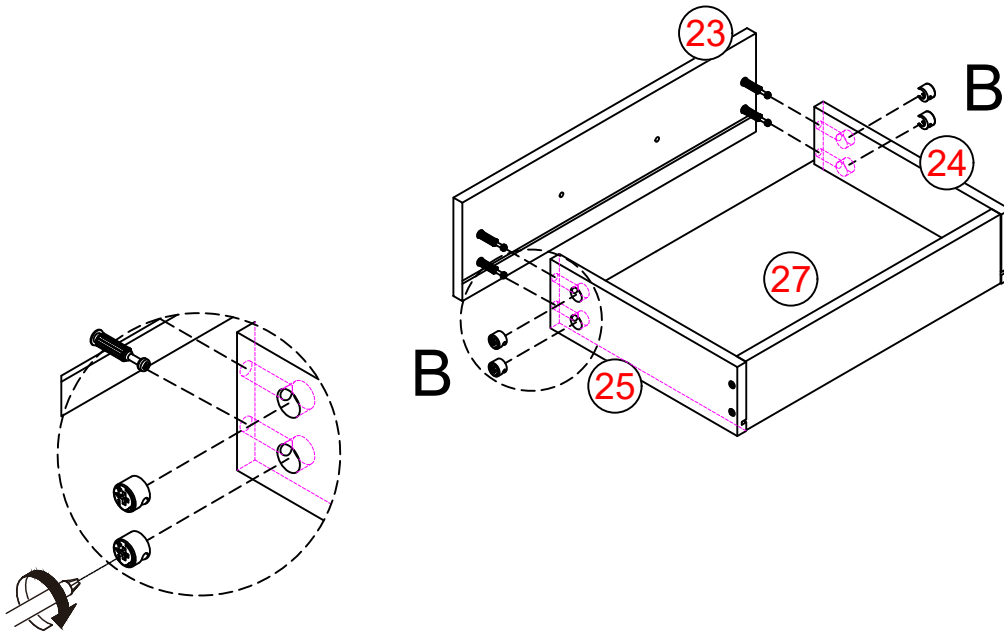

Step: 66

H

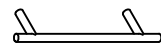

1

P



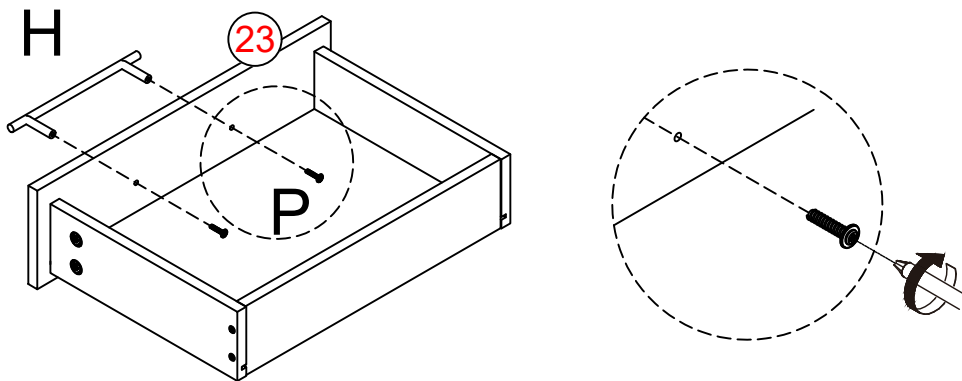

M4X 22

2

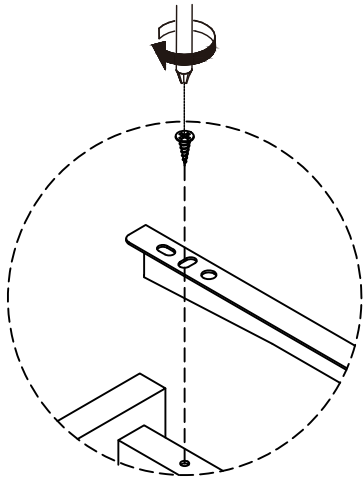

Step: 67



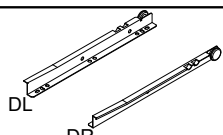

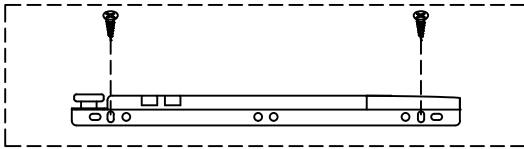
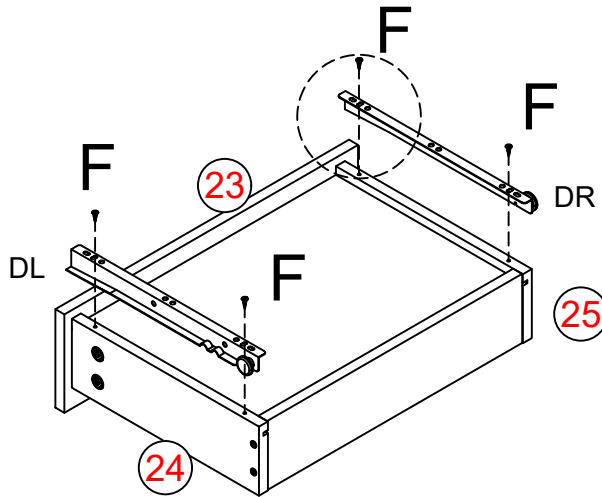
F	 M3.5X12	4
L		2

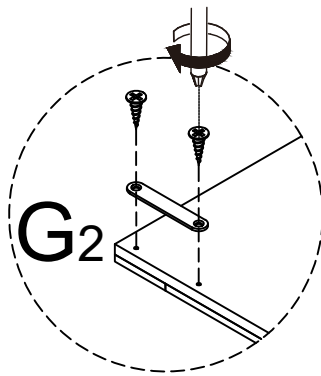

Step: 68



F	 M3.5X12	4
G		2

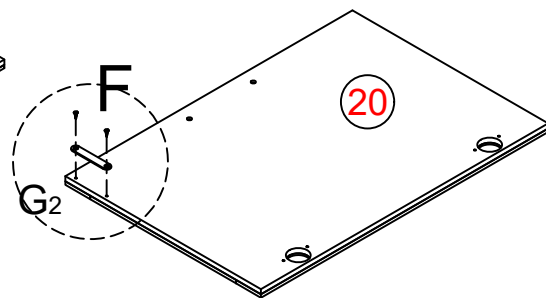
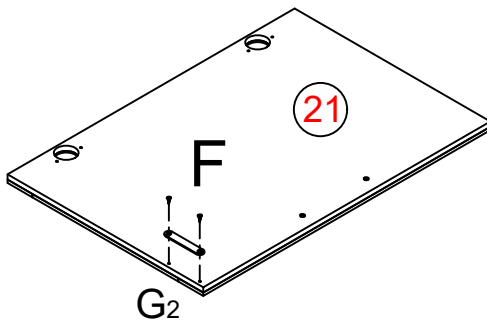

Step: 69

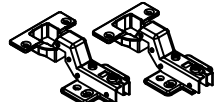
F	 M3.5X12	8
R		2 Set

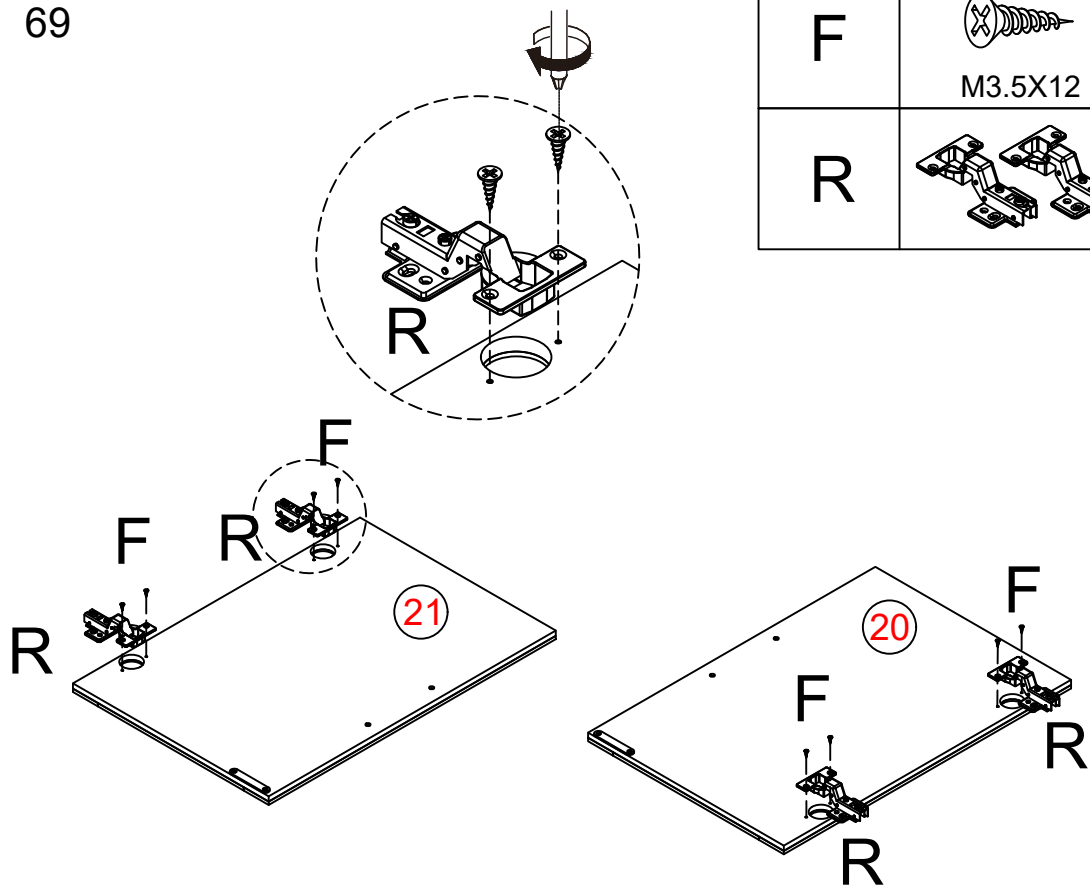

Step: 70

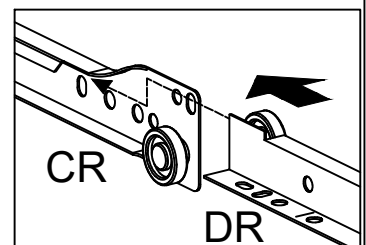
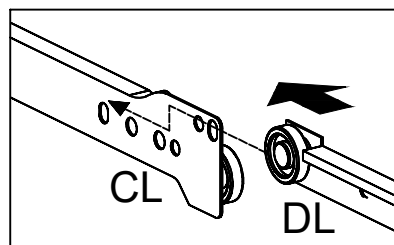
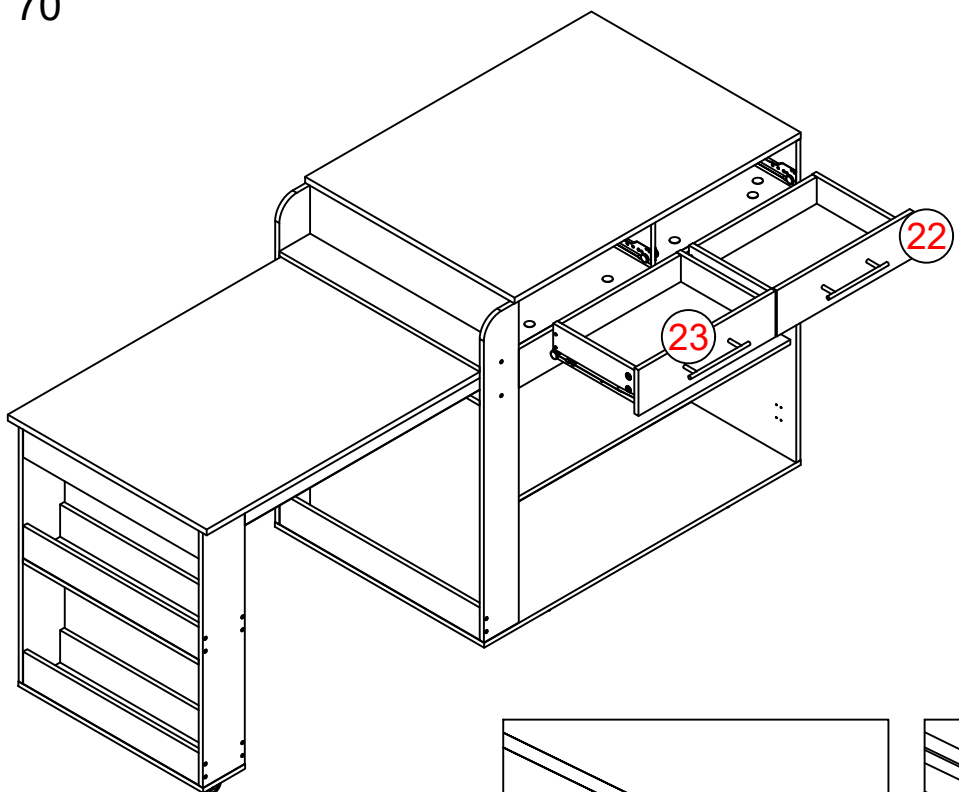

Step: 71

F



M3.5X12

4

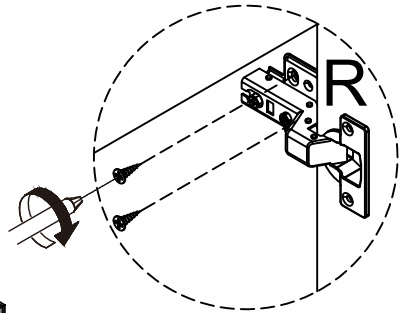
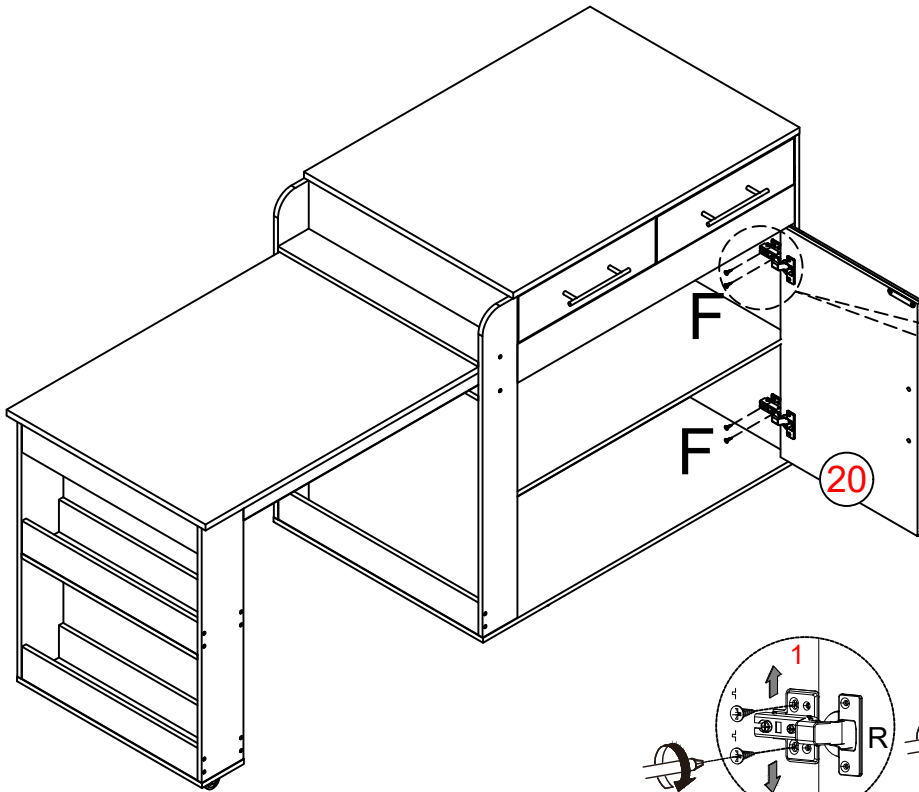

Here to install, first install the 2 oval holes of the R-numbered parts, and then adjust the R-numbered parts as shown the figure: 1/2/3 to make the cabinet door gap uniform, and then lock the remaining 2 round holes.

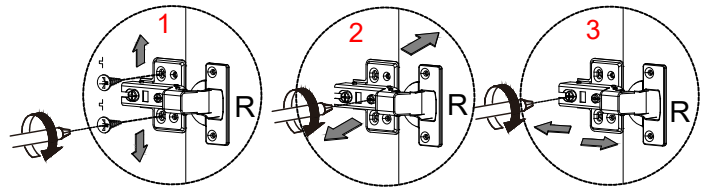

Step: 72

F



M3.5X12

4

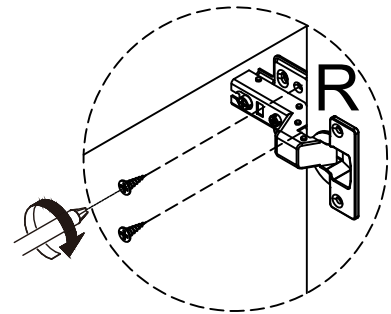
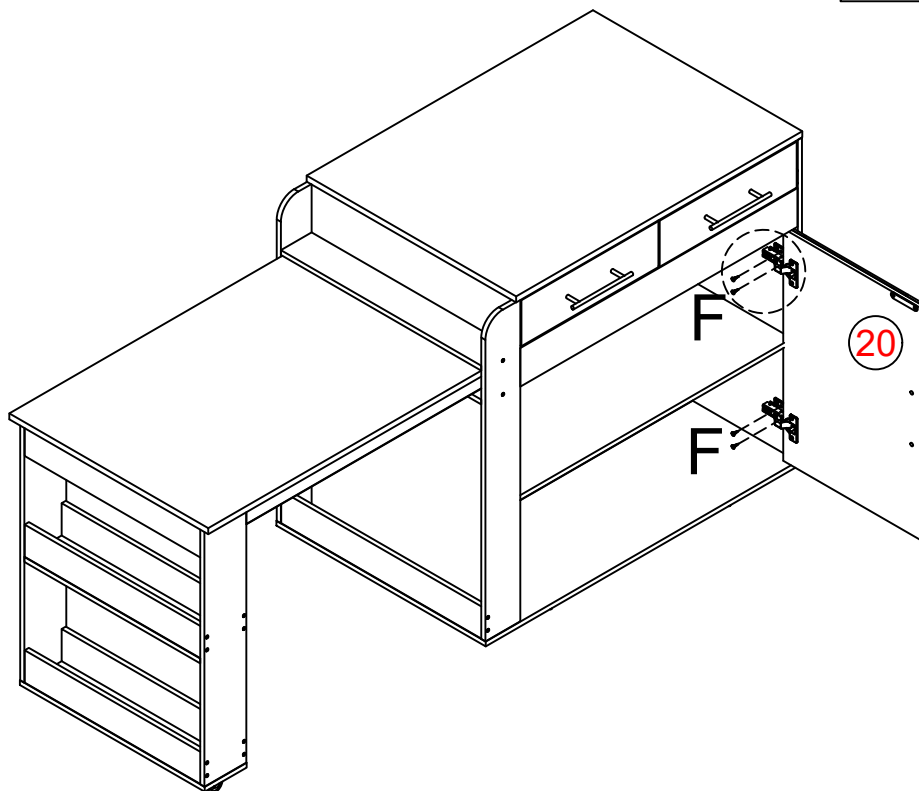

Step: 73

F



4

M3.5X12

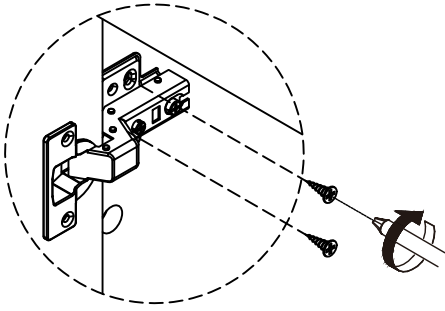

Here to install, first install the 2 oval holes of the R-numbered parts, and then adjust the R-numbered parts as shown the figure: 1/2/3 to make the cabinet door gap uniform, and then lock the remaining 2 round holes.

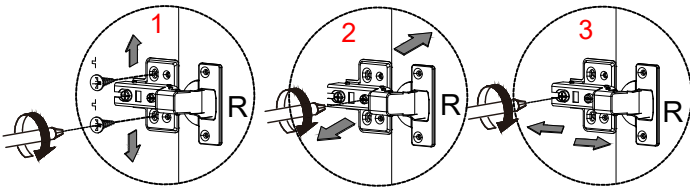
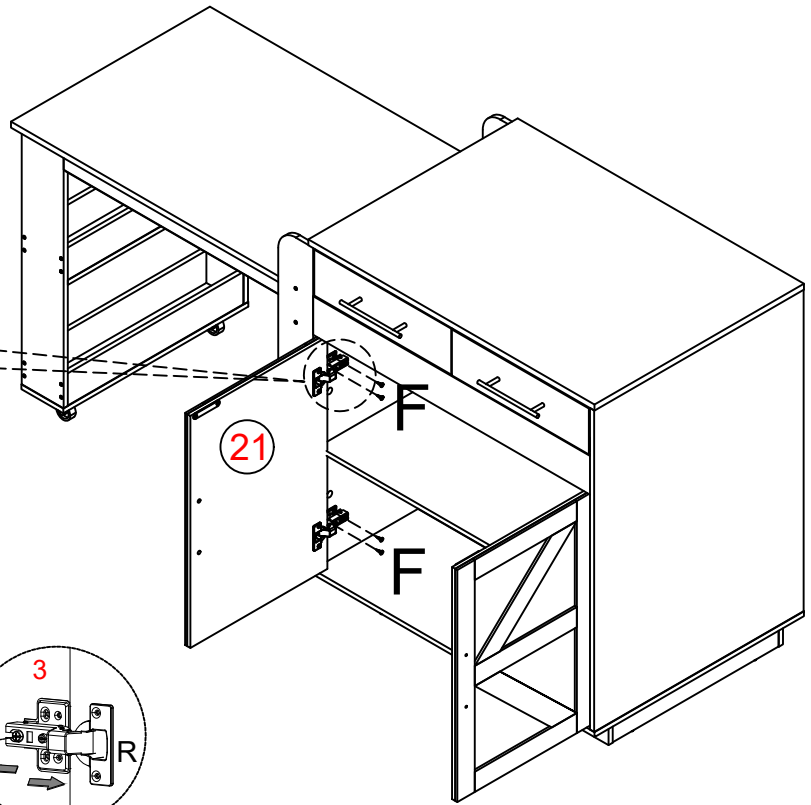

Step: 74

F



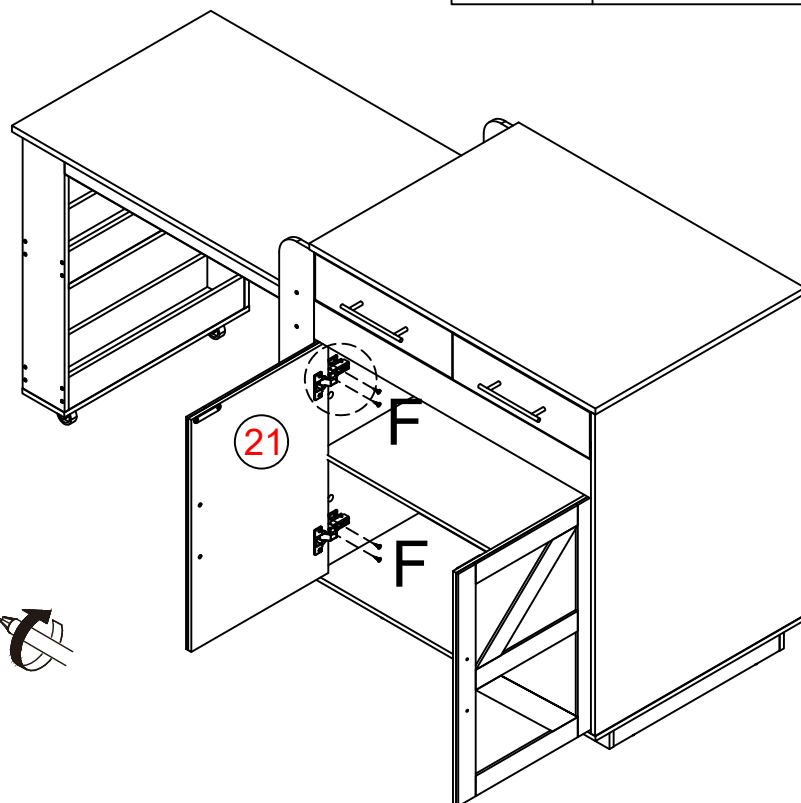
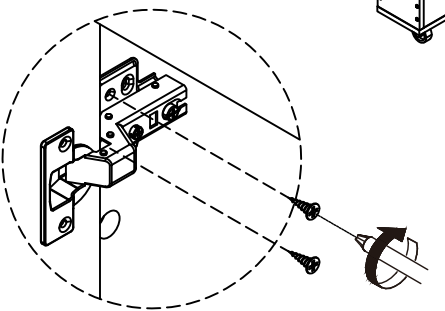

4

M3.5X12

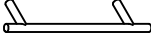

Step: 75

H		2
P	 M4X22	4

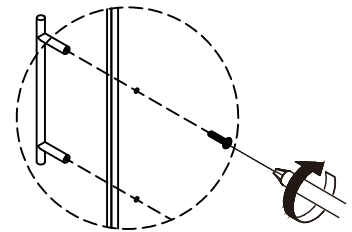
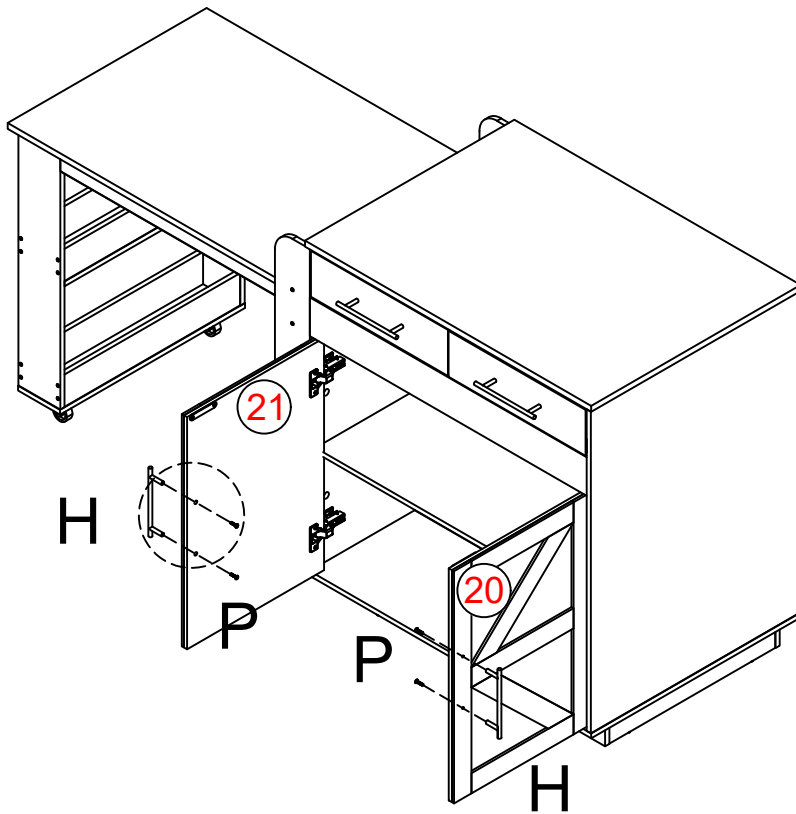

Step: 76

