

MBIS7242

72" x 42.125" x 21"

Installation: Alcove

Material: Acrylic

Plumbed Weight: 150 lbs / 68 kg

Soaker Weight: 125 lbs / 57 kg

Average Fill: 60 gal to above jet level

Maximum Fill: 100 gal to overflow



Package	Package Content	Part #
Soaker	Soaking bath - No jets. Integral front skirt, 3-sided integral tile flange and textured bottom.	MBIS7242
Air Bath	12 air jets, heated air blower, pre-leveled foam base and textured bottom. <i>pre-leveled foam base increases overall tub height 2"-3"</i>	MBAIS7242
Whirlpool	6 point-massage jets, 1-bhp pump, integral front skirt, 3-sided integral tile flange and textured bottom.	MBWIS7242

Options *Must be ordered at time of purchase.*

Standard White (no charge)

Color Upgrade: Biscuit (MTISCOLOR)

Quick Ship / Priority

Soaker & Whirlpool (QSHIPMTIS)

Airbath (QSHIPMTISA)

Inline Heater

For Whirlpool (HTRMTIS) uses existing pump

For Soaker & Air Bath (MBHTISOAK)

heater with recirculating pump

Accessories

Lift and Turn Drain & Overflow

Chrome (MBWOC), White (MWOW),

Brushed Nickel (MBWOBN)

Pillows

Soft Pillow

White (MBPSW) Black (MBPSB)

Roll-Up Pillow

Light Aqua (MBPRUC) Black (MBRUB)

Installation Options. *Must be ordered at time of purchase.*

Pre-Leveled Foam Base

5' Tubs (MBPLFOAM)

5.5' & 6' Tubs (MBPLFOAM2)

All airbaths include a pre-leveled foam base.



Shown with Whirlpool Package

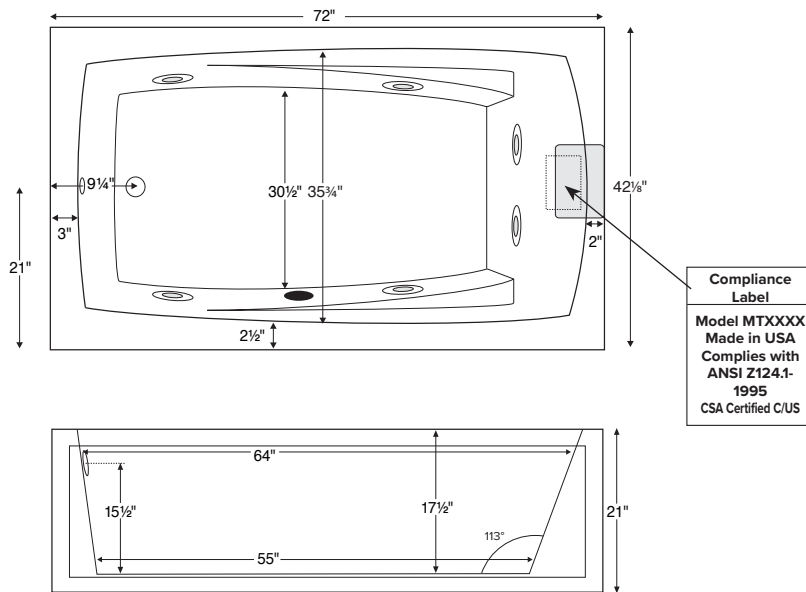

Important Ordering and Installation Information

- Before ordering or installing, consider access to equipment.
- Must specify left- or right-hand drain when ordering.
- Tubs equipped with hydrotherapy components have a removable front panel.
- Use proper bedding compound to fully level and support the tub.
- Tubs equipped with an air system or factory installed pre-leveled foam base are designed to install directly onto a flat level subfloor.
- Location of all therapy components is predetermined and cannot be changed.
- Suction and control locations may vary.
- Options listed cannot be combined with Designer Collection options.

- Before discarding tub crate, check for accessories that may be packaged inside.
- All product measurements are ±1/2".
- Specifications and configurations are subject to change without notice.
- Measurements herein supersede all others published prior to publication date below.

CSA # MTIS-IS7242

Effective 030121

Hydrotherapy Package	Components Included	GFCI / 110V
Soaker with Optional Inline Heater	½-bhp pump, inline heater	1-15 amp
Whirlpool or Air Bath	1-bhp pump	1-15 amp
Whirlpool with Optional Inline Heater	1-bhp pump, inline heater	1-20 amp
Air Bath with Optional Inline Heater	heated blower, ½-bhp pump, inline heater	2-15 amp

CSA Certified C/US; ANSI Z124.1 and ANSI 112.19.7

NOTE: *Filling this tub to the maximum may require an above average size or dedicated water heater.*

