

ASSEMBLY INSTRUCTION

COFFEE TABLE





30 min

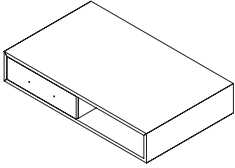
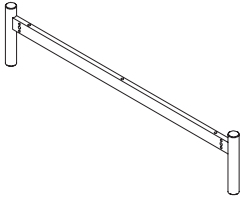
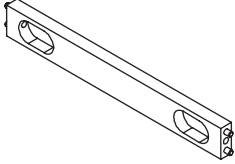
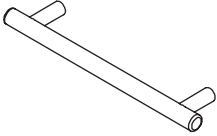

Thank you for purchasing this quality product. Be sure to check all packing material carefully for small parts which may have come loose inside the carton during shipment. Identify and count all parts and compare with the parts list below.

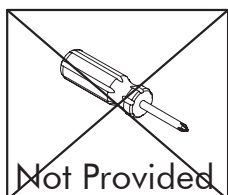
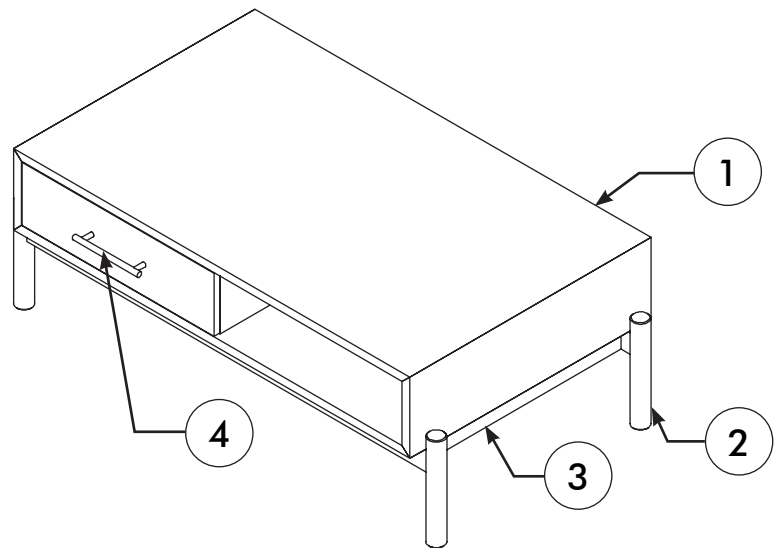

1	COFFEE TABLE 	1 PC
2	LEG 	2 PCS
3	RAIL 	2 PCS
4	HANDLE 	2 PCS

A	M6 x 50 	12 PCS
B	ARC WASHER 	4 PCS
C	ALLEN KEY 	1 PC



NOTICE: DO NOT use the power tools for assembly.
 This can cause the bolts to be over tightened.
 DO NOT over tighten hardware, damage may occur.

STEP 1

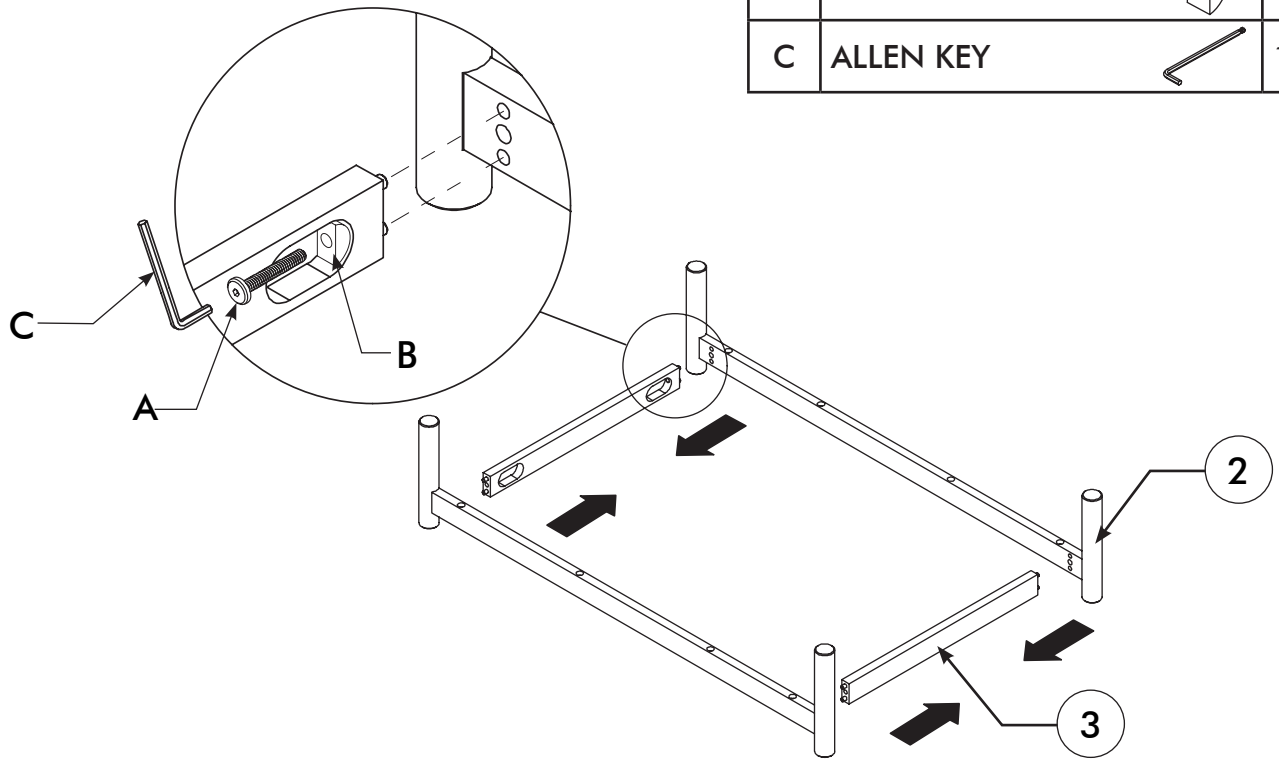

A	M6 x 50		4 PCS
B	ARC WASHER		4 PCS
C	ALLEN KEY		1 PC



NOTICE: When assembling, place all parts on a soft, clean, and flat surface such as a carpet to prevent scratches.

STEP 2

LAY THE COFFEE TOP DOWN ON THE GROUND BEFORE ASSEMBLING.

A	M6 x 50		8 PCS
C	ALLEN KEY		1 PC

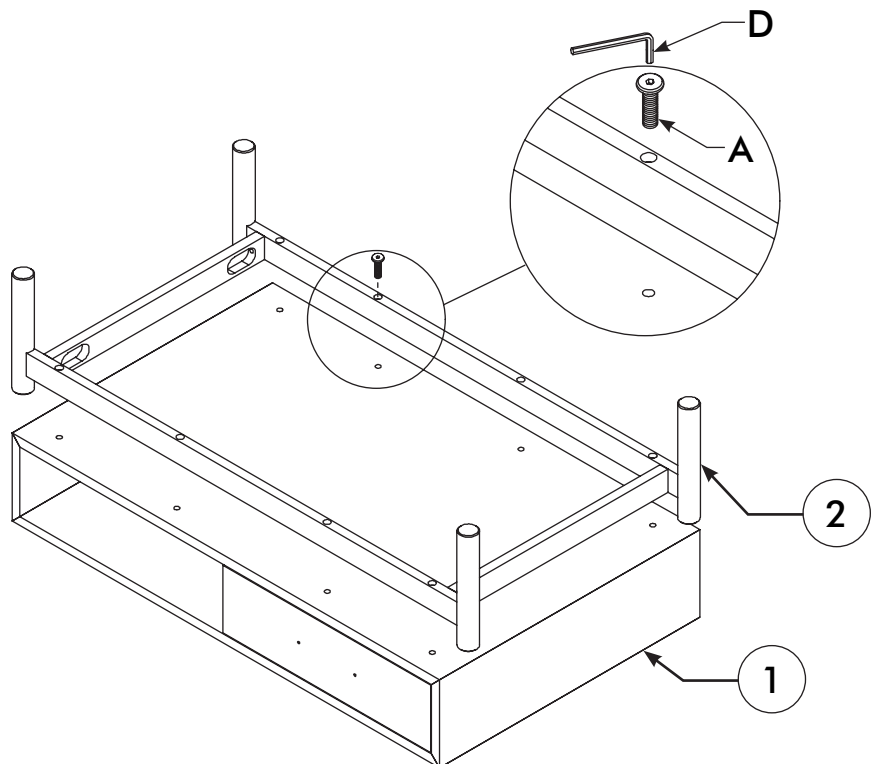

NOTICE: When assembling, place all parts on a soft, clean, and flat surface such as a carpet to prevent scratches.

STEP 3

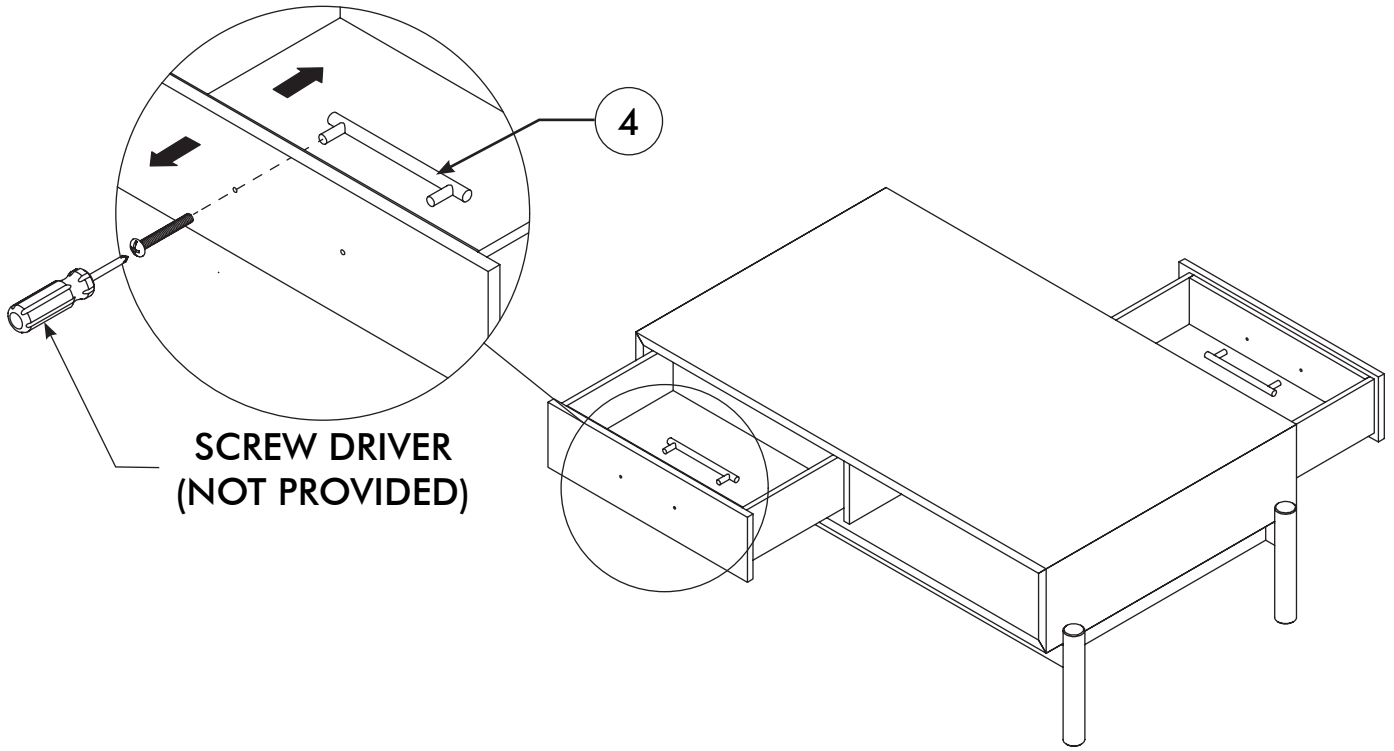

STEP 4

