

# *ASSEMBLY INSTRUCTIONS*



***OFFICE DESK***

# ASSEMBLY INSTRUCTIONS

## ASSEMBLY TIPS:

1. Remove hardware from box and sort by size.
2. Please check to see that all hardware and parts are present prior to start of assembly.
3. Please follow attached instructions in the same sequence as numbered to assure fast & easy assembly.



### WARNING!

1. Don't attempt to repair or modify parts that are broken or defective. Please contact the store immediately.
2. This product is for home use only and not intended for commercial establishments.



ASSEMBLY TIME

70 MINUTES

## PARTS IDENTIFICATION

A	LEFT SIDE PANEL		1 PC	G	SMALL CROSS BRACE		1 PC
B	RIGHT SIDE PANEL		1 PC	H	LEFT DRAWER FRONT PANEL		1 PC
C	MIDDLE DIVIDER PANEL		1 PC	I	LEFT DRAWER BACK PANEL		1 PC
D	BACK PANEL		1 PC	J	SMALL LEFT DRAWER SIDE PANEL		3 PCS
E	TOP PANEL		1 PC	K	SMALL RIGHT DRAWER SIDE PANEL		3 PCS
F	LARGE CROSS BRACE		1 PC	L	LEFT DRAWER BOTTOM PANEL		1 PC

### NOTE:



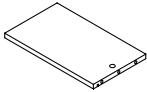
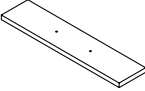
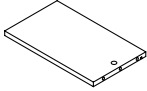
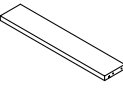
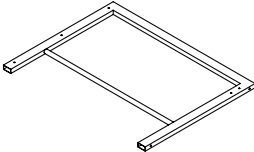
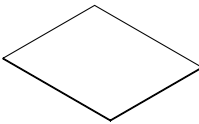
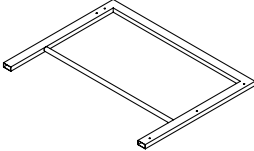
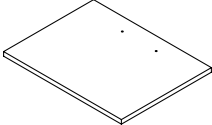
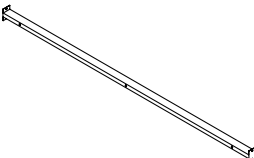
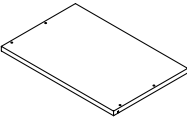



Phillips head screw driver is required in the assembly process; however, manufacturer does not provide this item.

M	LEFT DRAWER BOTTOM SUPPORT		2 PCS	S	LARGE LEFT DRAWER SIDE PANEL		1 PC
N	SMALL DRAWER FRONT PANEL		2 PCS	T	LARGE RIGHT DRAWER SIDE PANEL		1 PC
O	SMALL DRAWER BACK PANEL		2 PCS	U	LEFT METAL FRAME		1 PC
P	SMALL DRAWER BOTTOM PANEL		3 PCS	V	RIGHT METAL FRAME		1 PC
Q	LARGE DRAWER FRONT PANEL		1 PC	A1	LOWER CROSSBAR		1 PC
R	LARGE DRAWER BACK PANEL		1 PC				

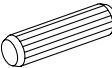
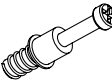
**NOTE:**

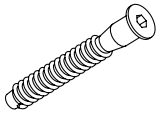
Phillips head screw driver is required in the assembly process; however, manufacturer does not provide this item.

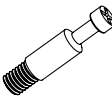
## HARDWARE IDENTIFICATION





Z							
NO	DESCRIPTION	FIGURE	Q'TY	NO	DESCRIPTION	FIGURE	Q'TY
1	GLUE 40g		1 PC	10	HANDLE		4 PCS
2	WOODEN DOWEL Ø8x30mm		26 PCS	11	HANDLE BOLT Ø4x28mm BLK		8 PCS
3	CAM BOLT Ø7x35.5mm SR		23 PCS	12	BOLT M6x15mm BLK		4 PCS
4	CAM LOCK Ø15x12mm SR		29 PCS	13	BOLT Ø7x70mm BLK		3 PCS
5	SCREW Ø4.5x42mm SR		6 PCS	14	FLOOR PROTECTOR 40x20mm		4 PCS
6	SCREW Ø4.3x35mm SR		18 PCS	15	PLASTIC FEET		4 PCS
7	CAM BOLT M6x31.5mm BLK		6 PCS	16	ALLEN WRENCH 4mm SR		1 PC
8	GLIDES L = 350mm WHT		4 SET	17	IRON BAR Ø9.5x328mm SR		2 PCS
9	GLIDES SCREW Ø3x10mm SR		48 PCS	18	STICKER Ø20mm		6 PCS

Z8,Z10,Z17 not included in blister packaging.

**NOTE:**

Phillips head screw driver is required in the assembly process; however, manufacturer does not provide this item.

# STEP 1

- |  |  |
|--|--|
|  <b>2</b><br>x 10   |  <b>3</b><br>x 4  |
|  <b>8</b> x 4<br>CL |  <b>9</b><br>x 24 |

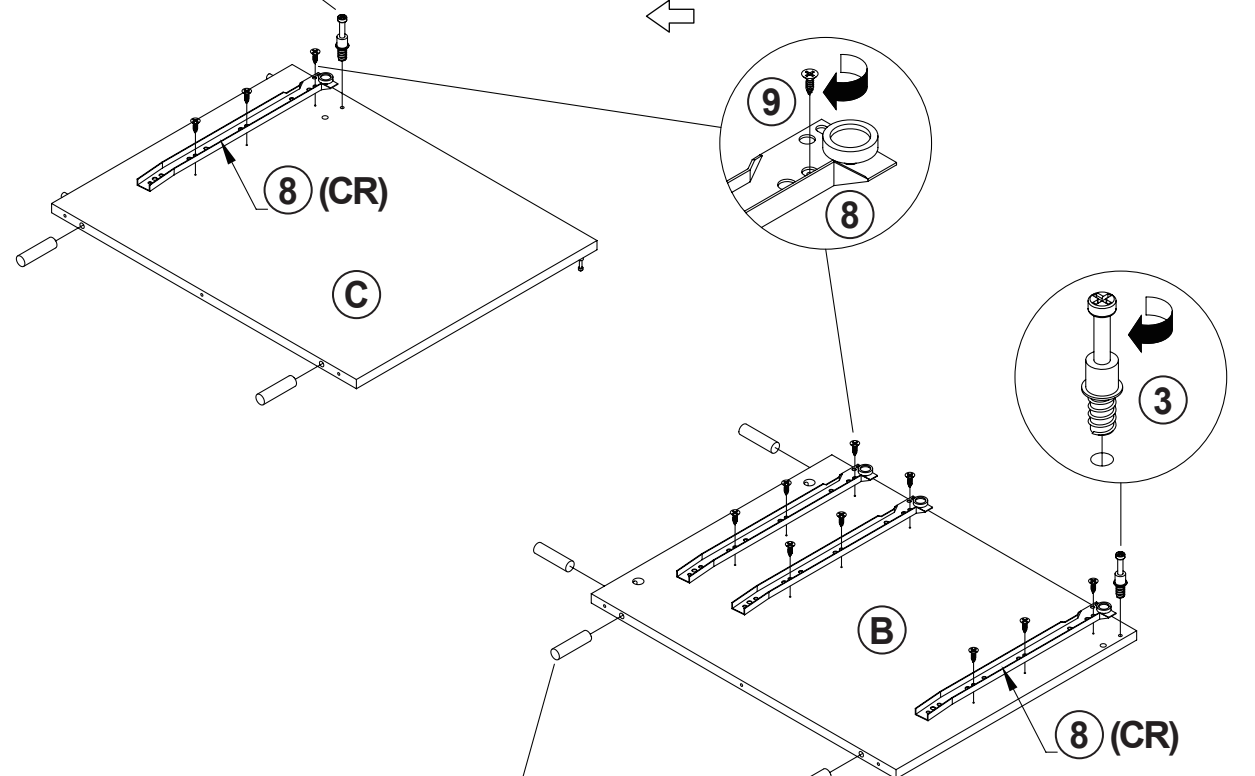
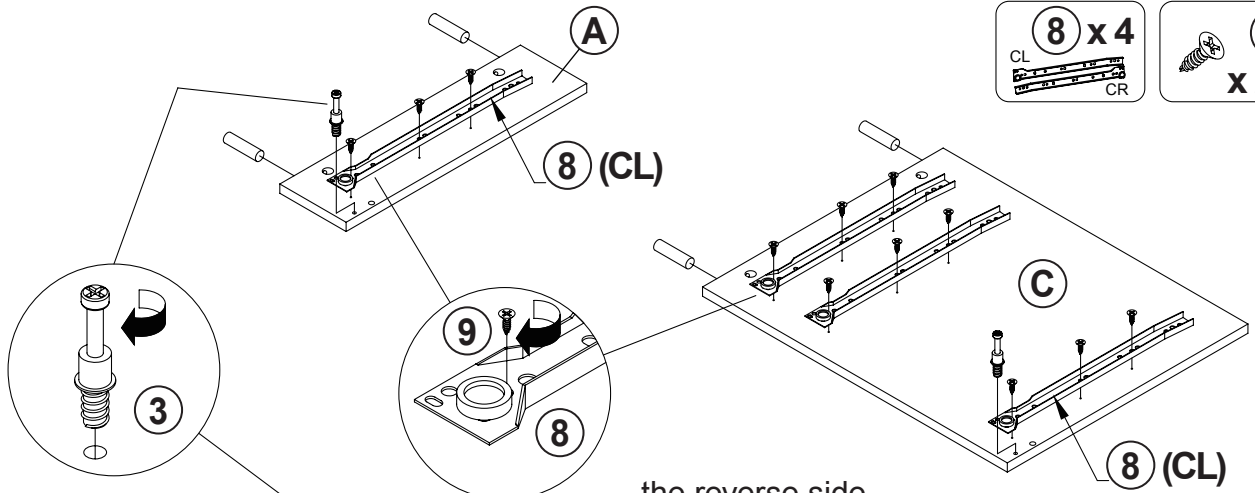

INCORRECT  
CORRECT

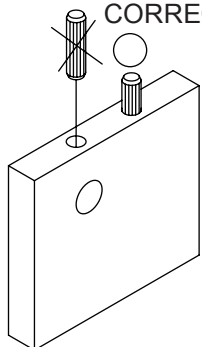

Apply glue on all wooden dowels to ensure integrity of the structure.

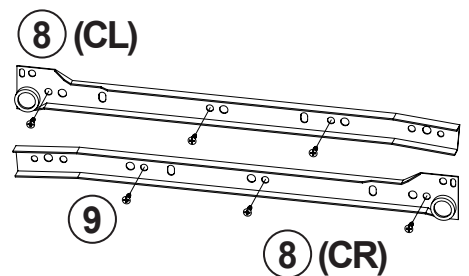
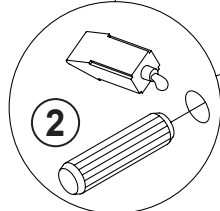

## STEP 2

**2**  
x 6

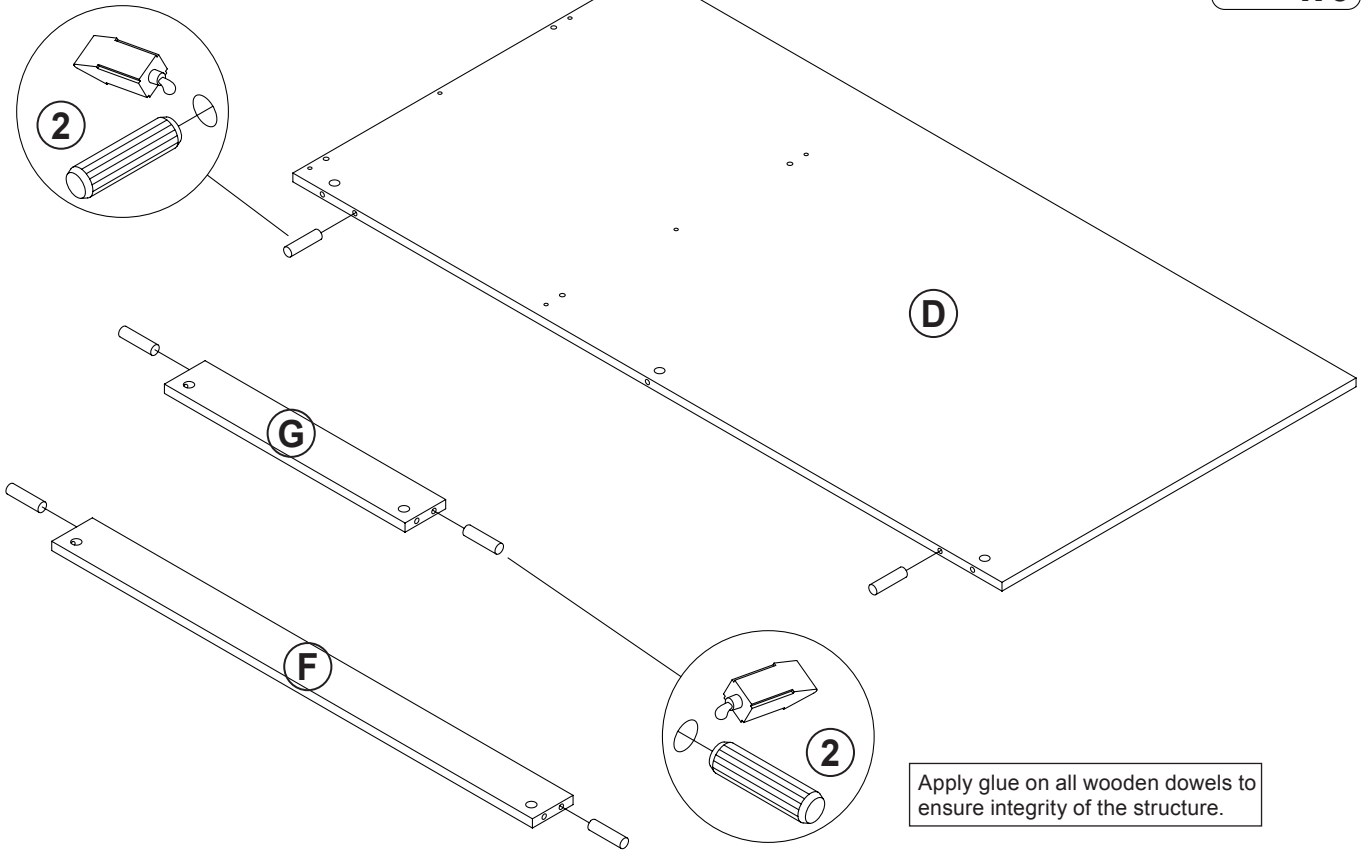

Apply glue on all wooden dowels to ensure integrity of the structure.

## STEP 3

**3**  
x 9

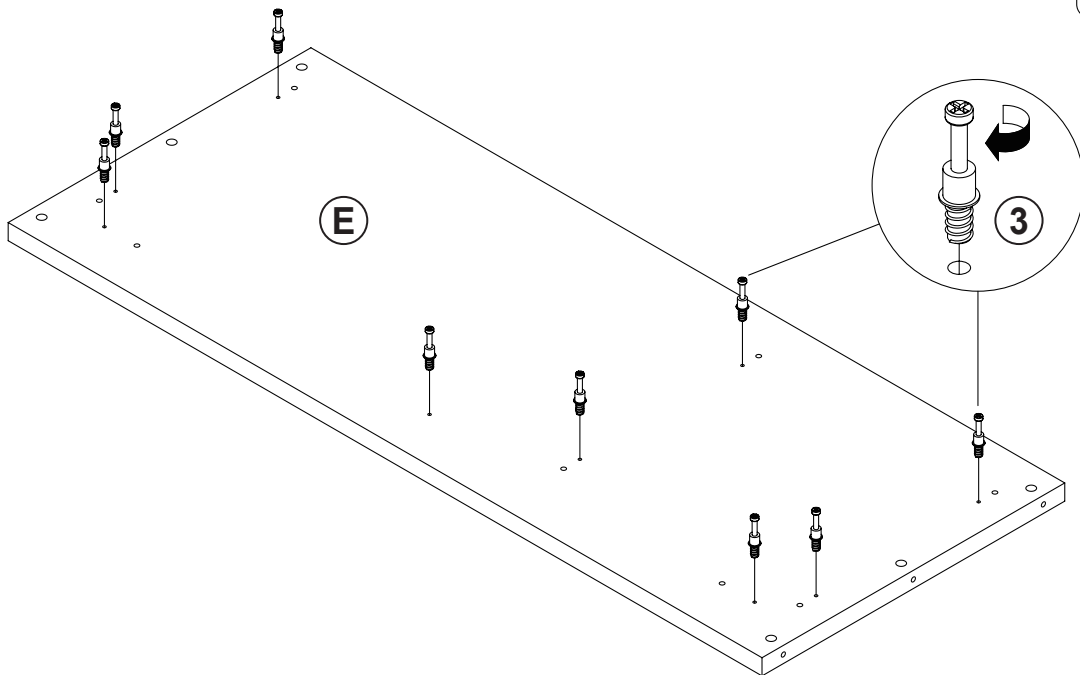

## STEP 4

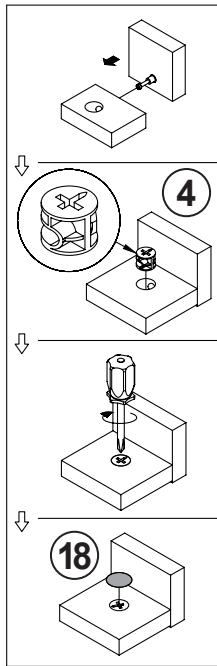

Apply glue on all wooden dowels to ensure integrity of the structure.

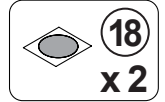
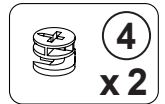
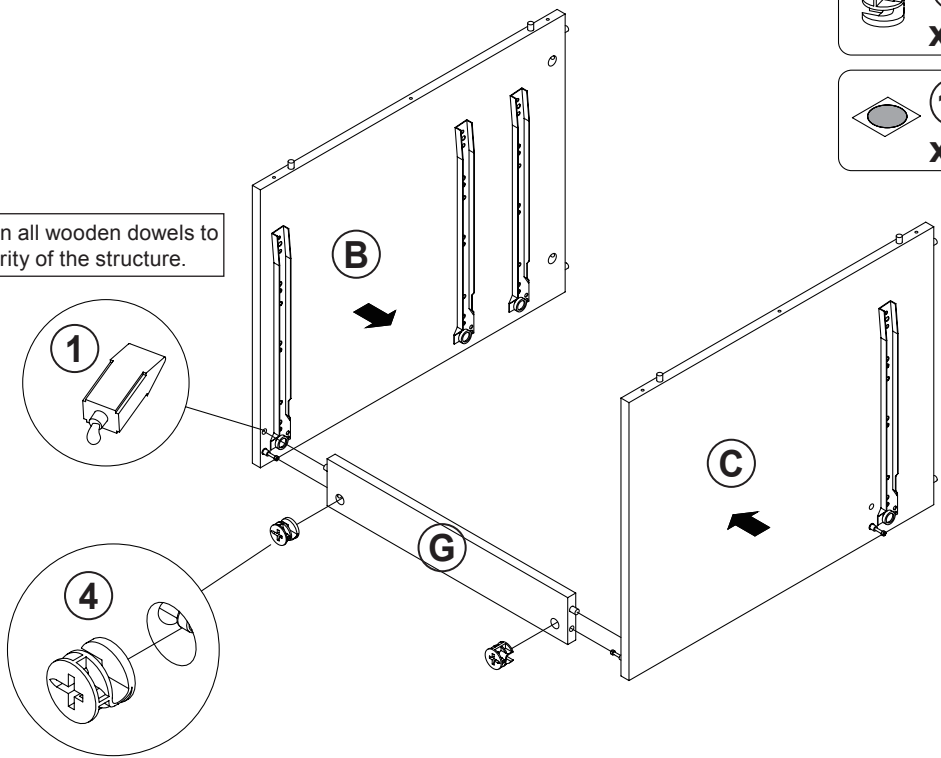

## STEP 5

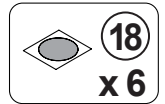
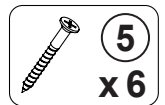
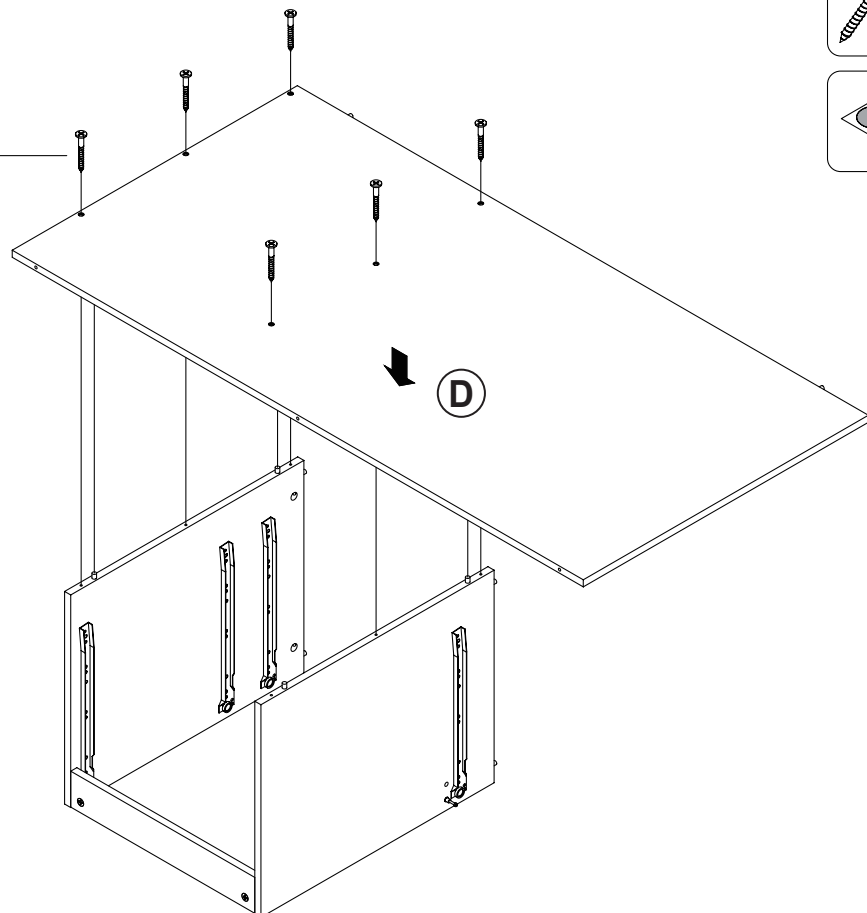
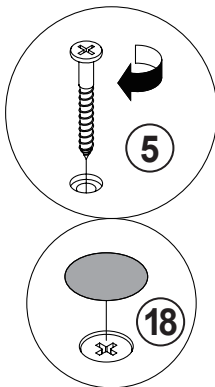

## STEP 6

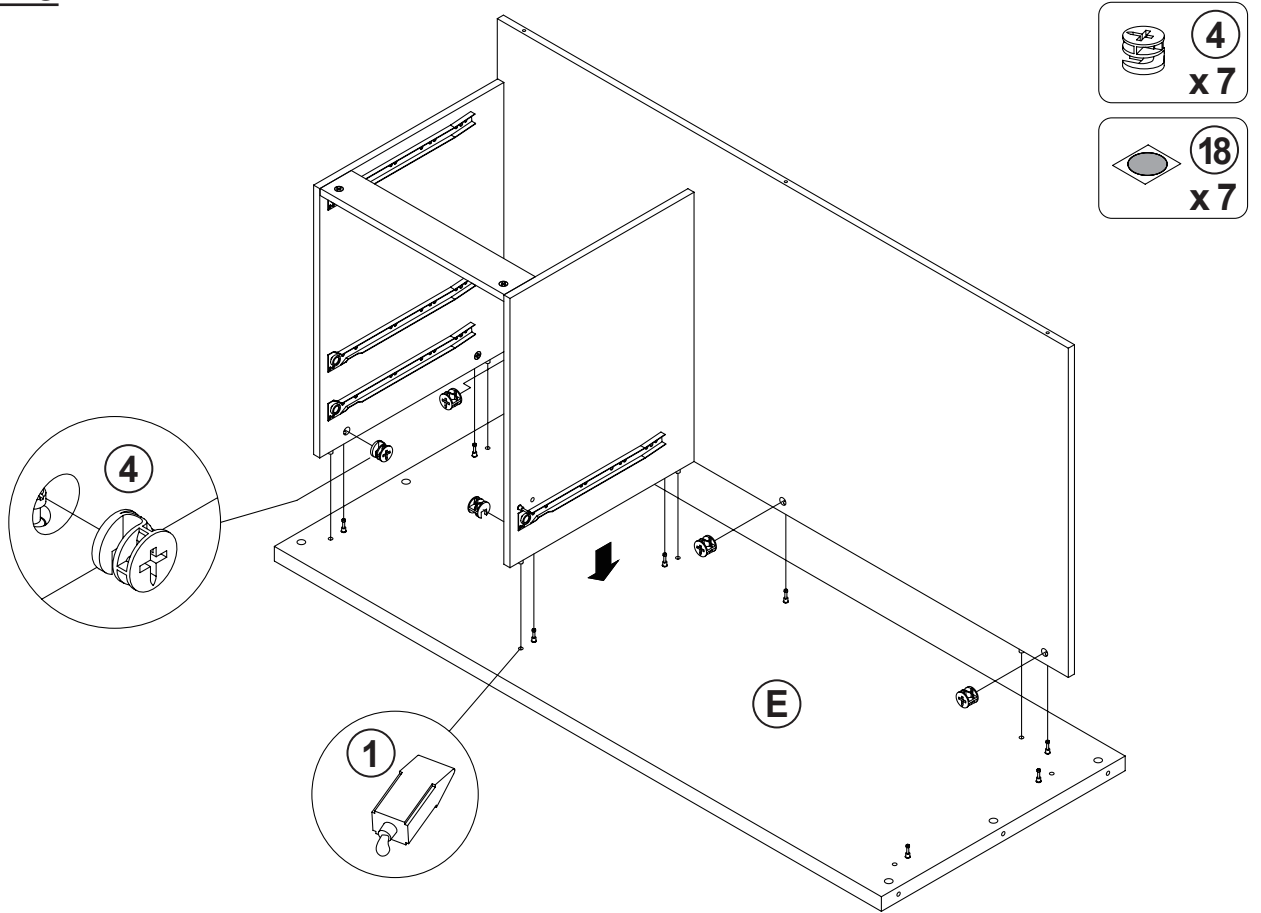

## STEP 7

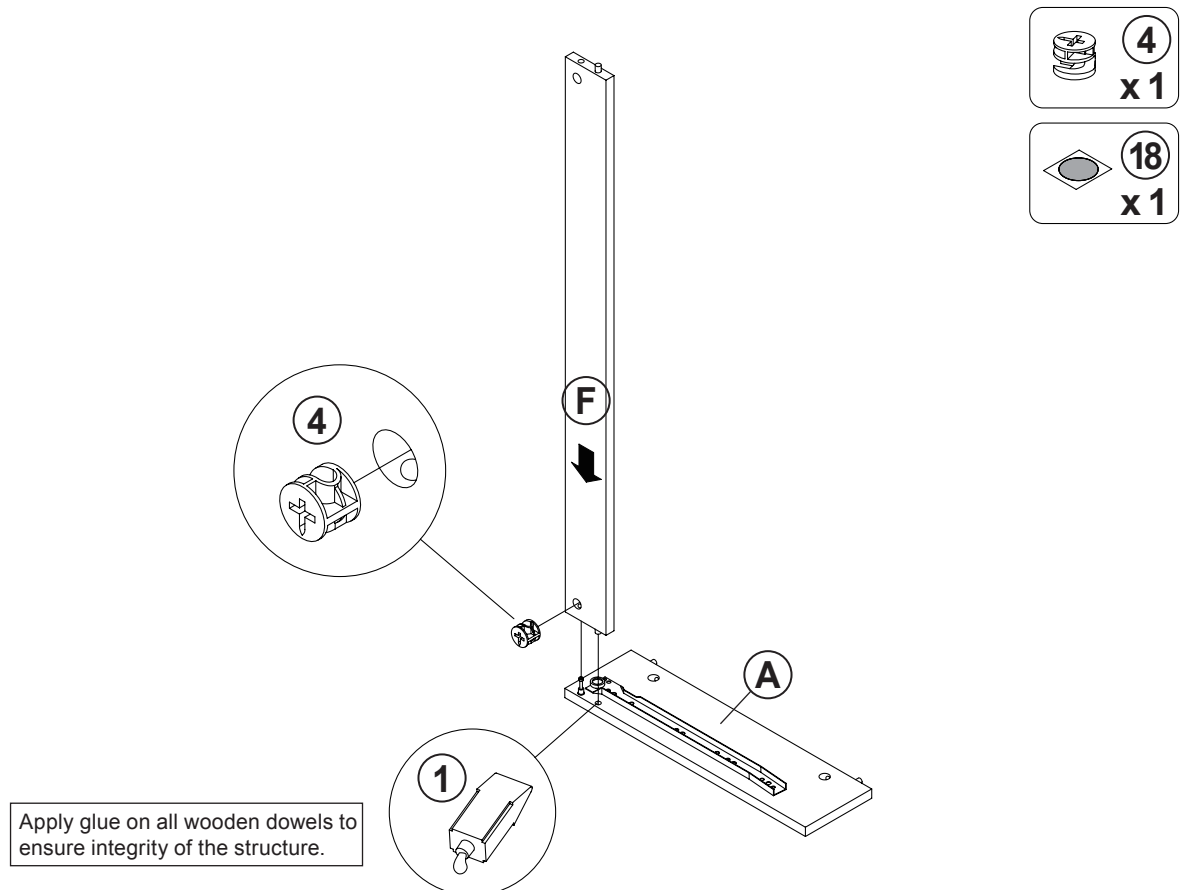

## STEP 8

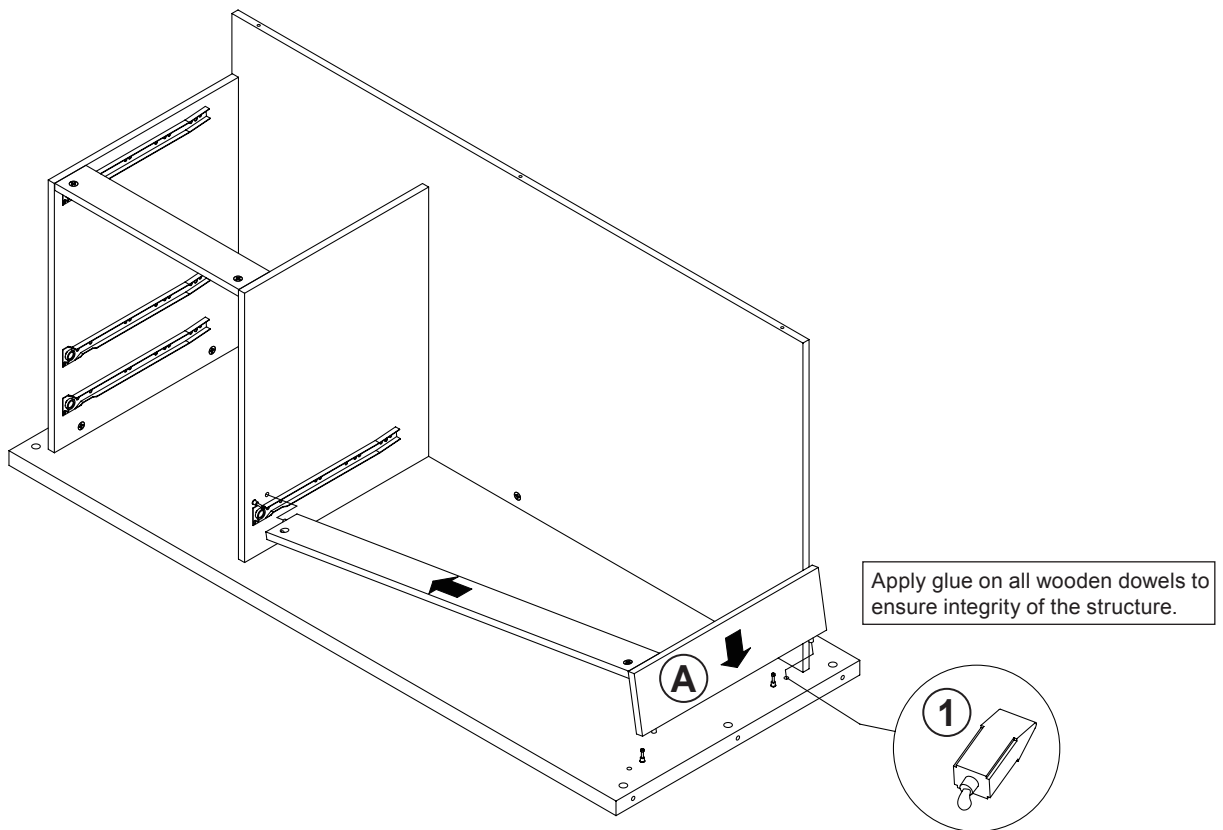

## STEP 9

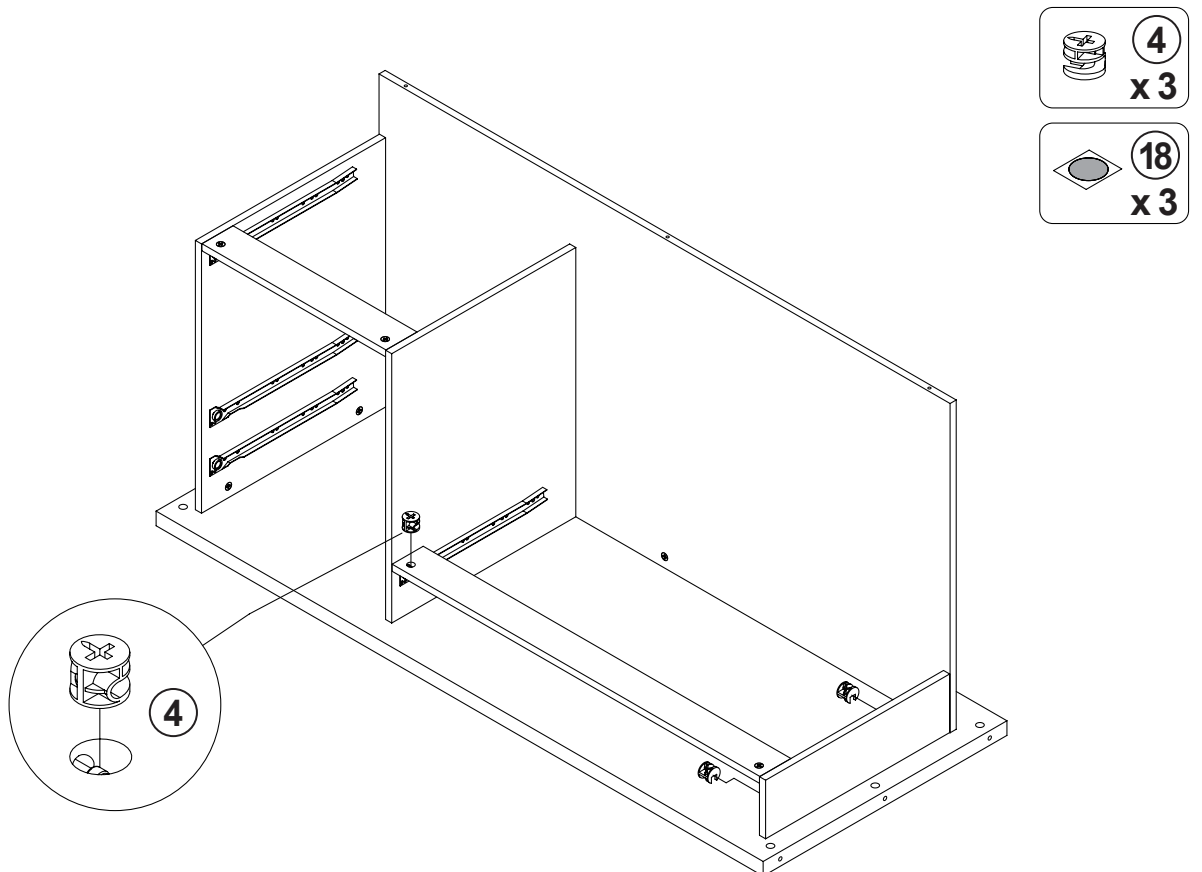

## STEP 10

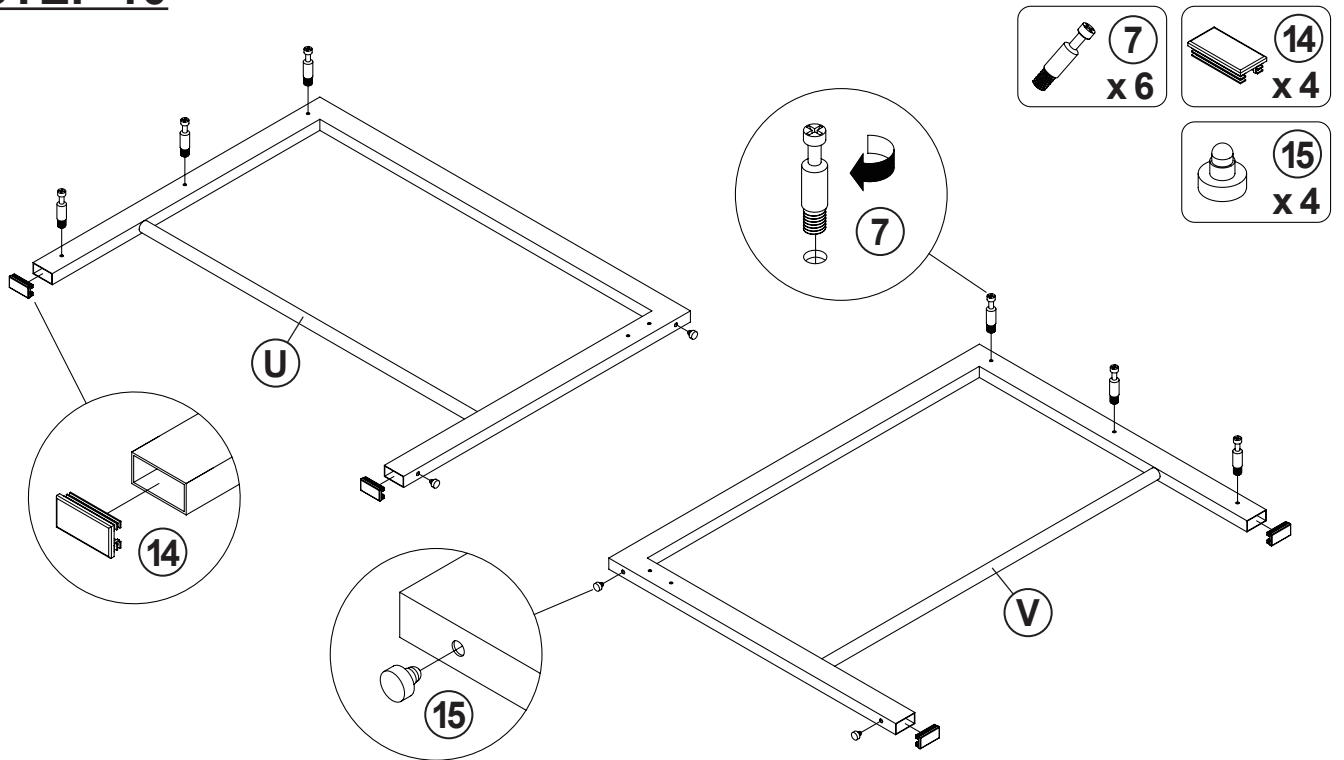

## STEP 11

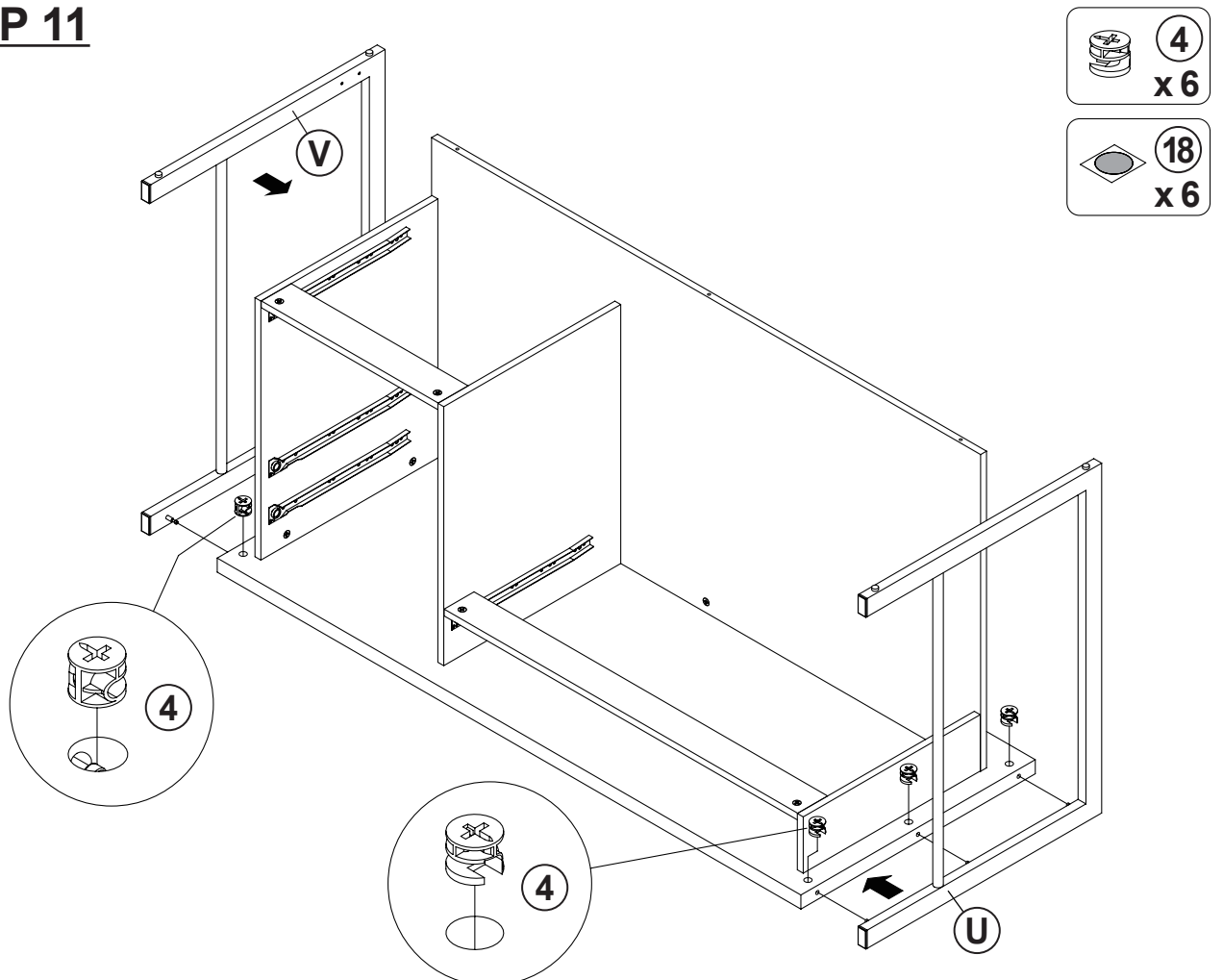

## STEP 12

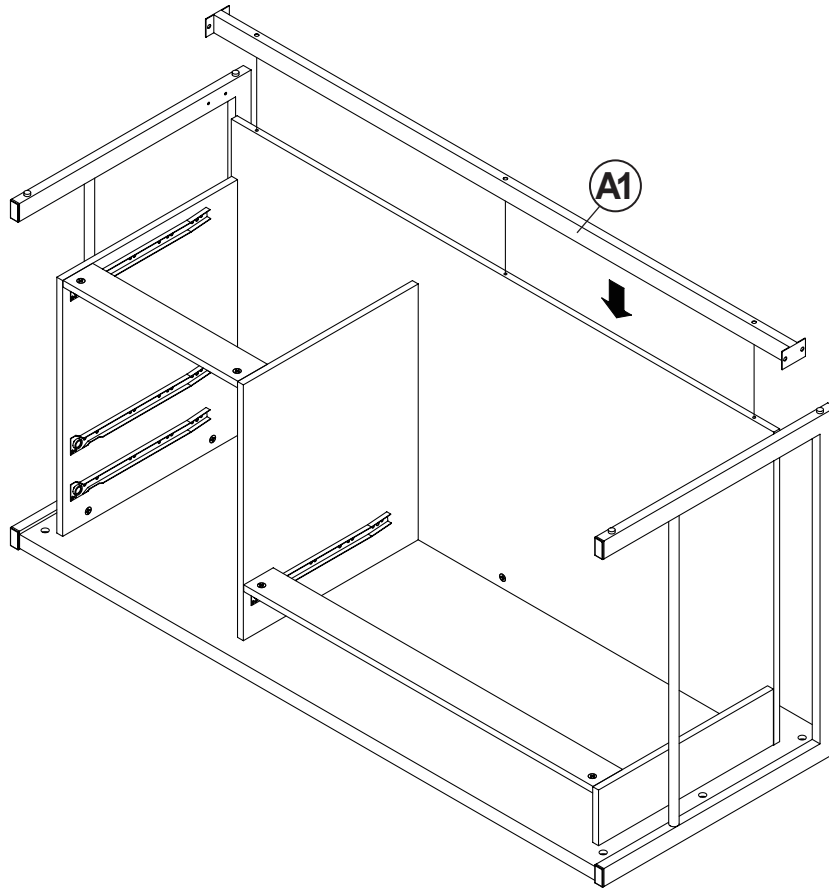

## STEP 13

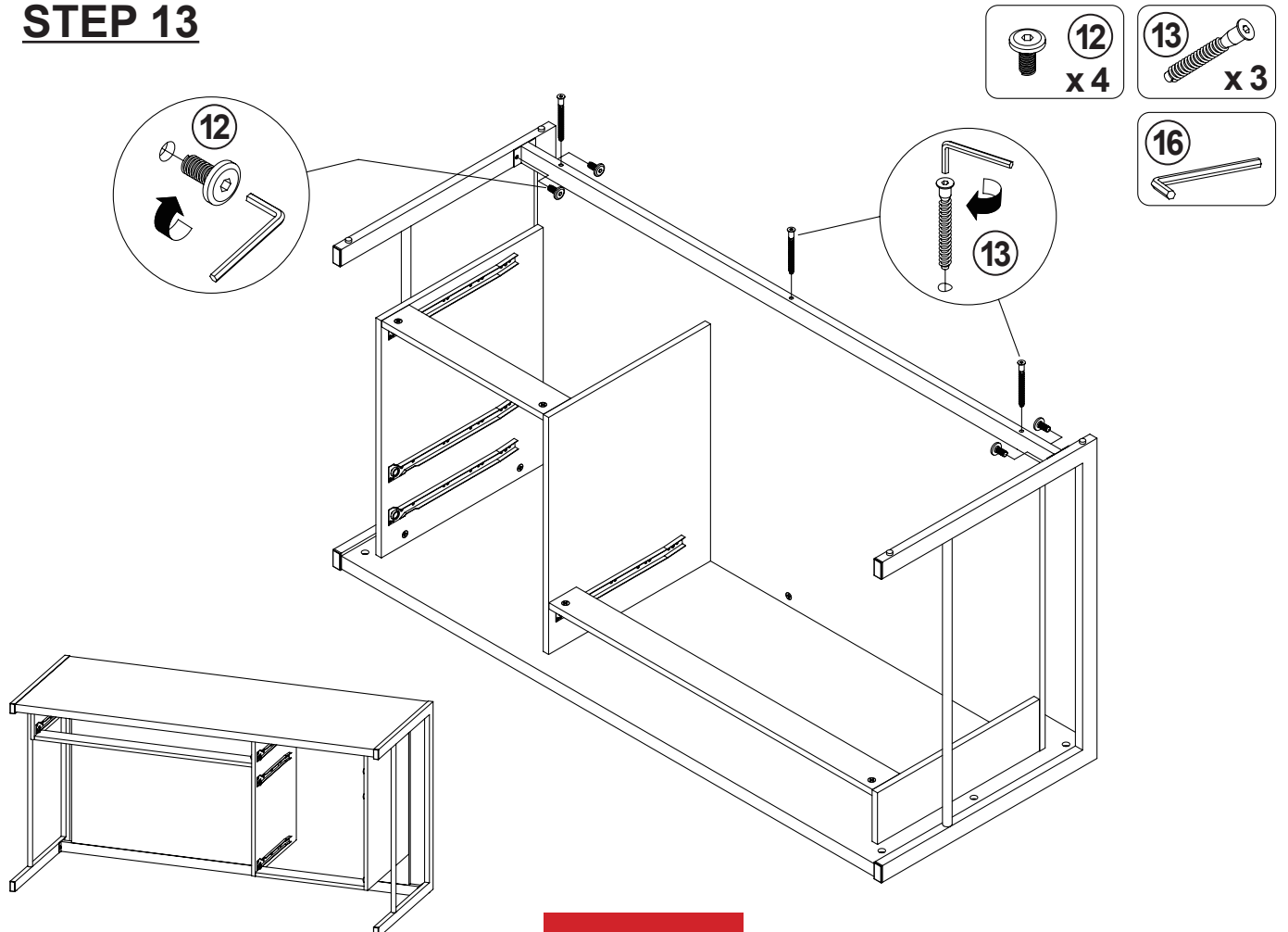

### STEP 14-1

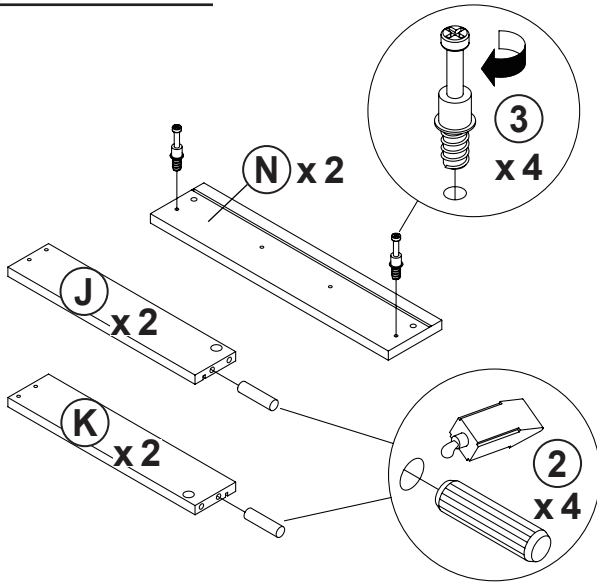

### STEP 14-2

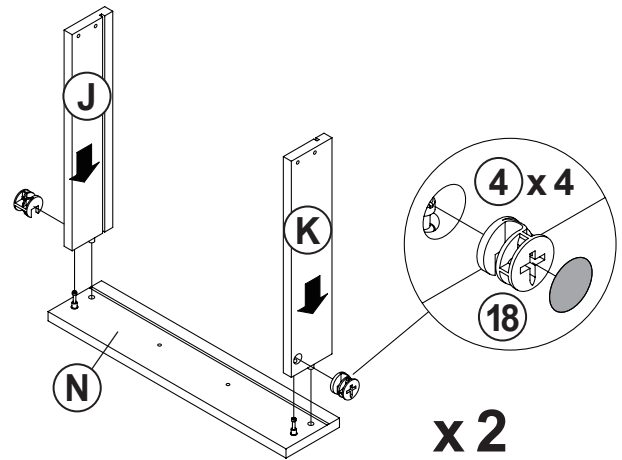

### STEP 14-3

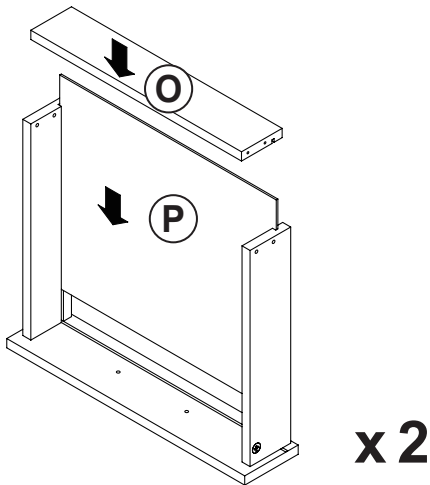

### STEP 14-4

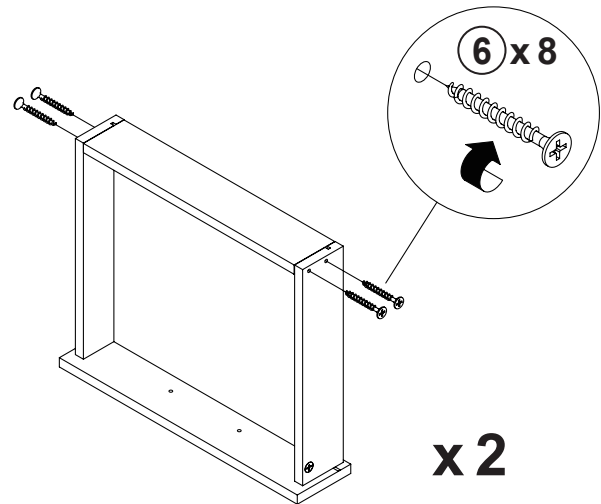

### STEP 14-5

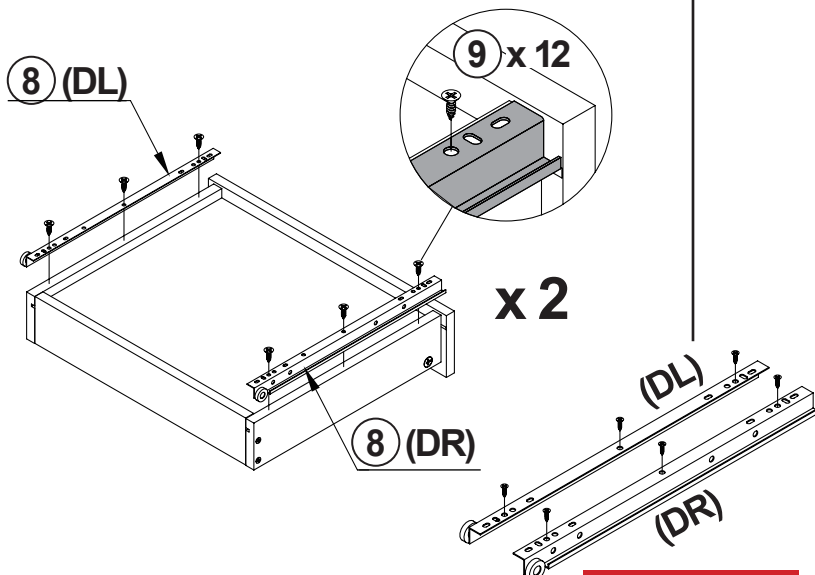

### STEP 14-6

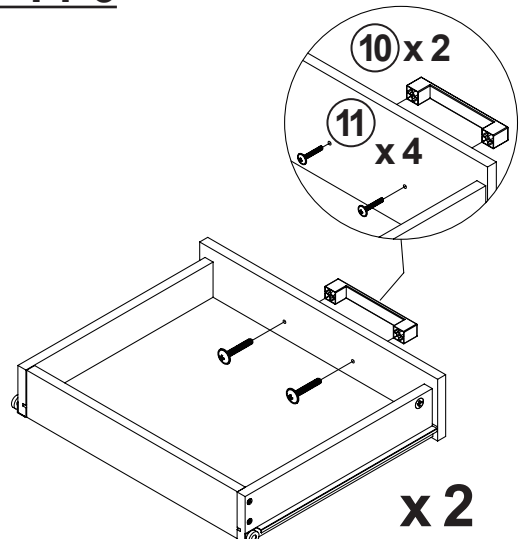

### STEP 15-1

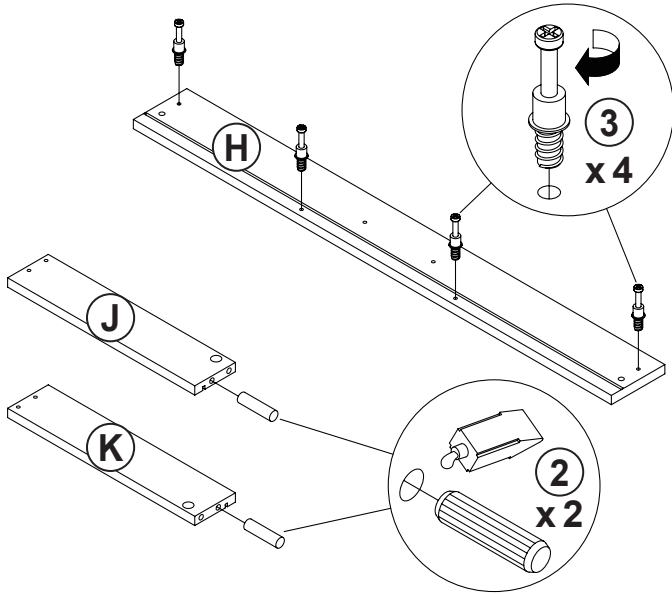

### STEP 15-2

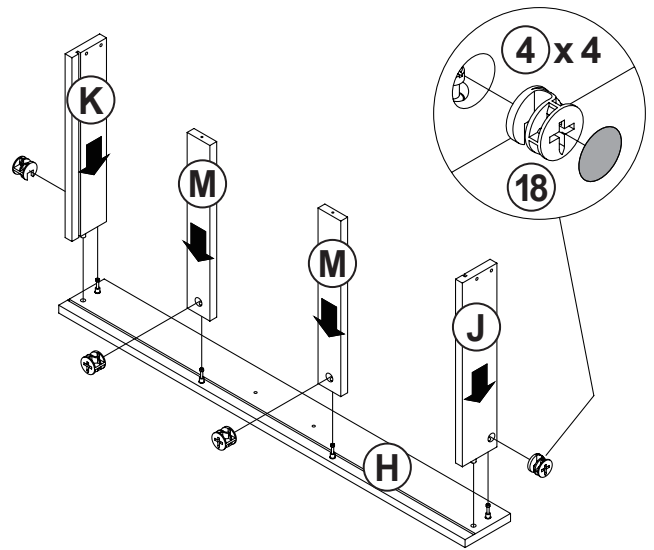

### STEP 15-3

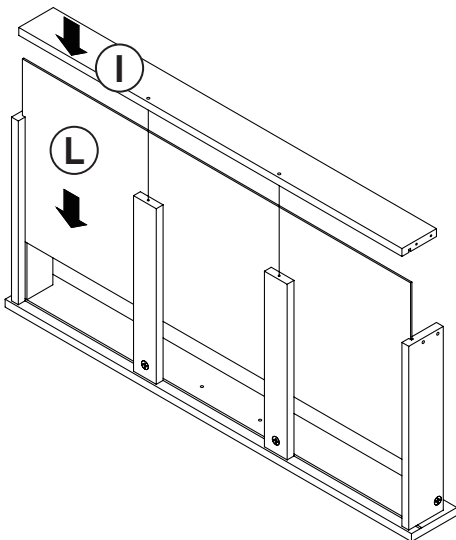

### STEP 15-4

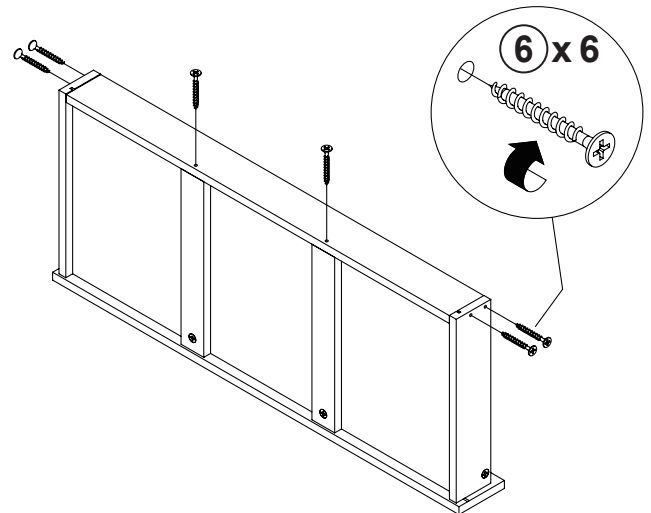

### STEP 15-5

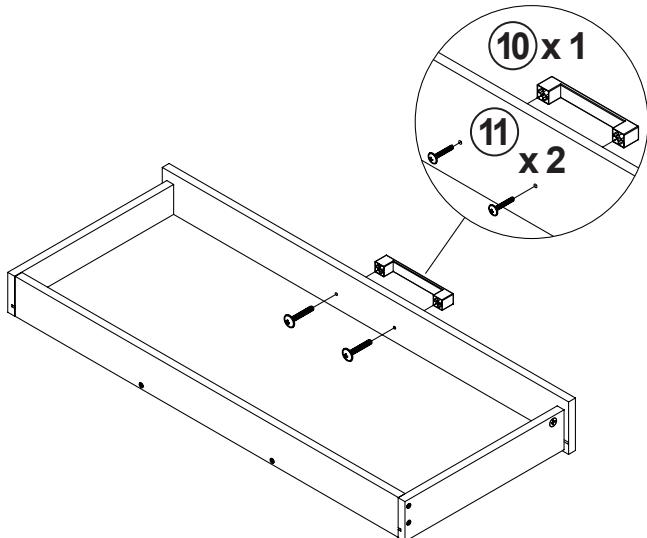

### STEP 15-6

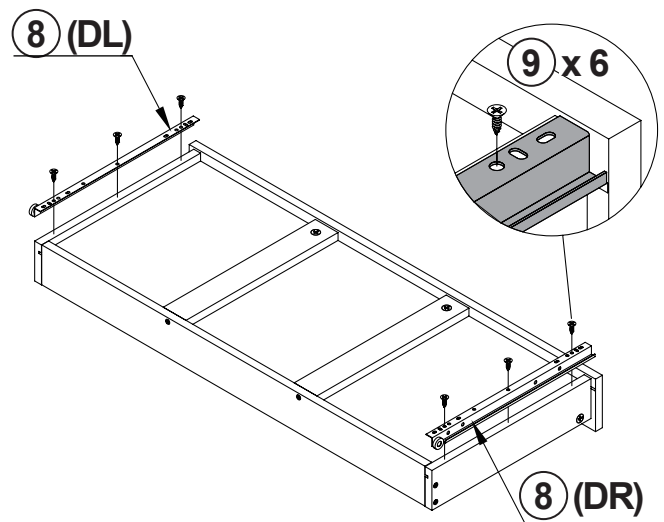

### STEP 16-1

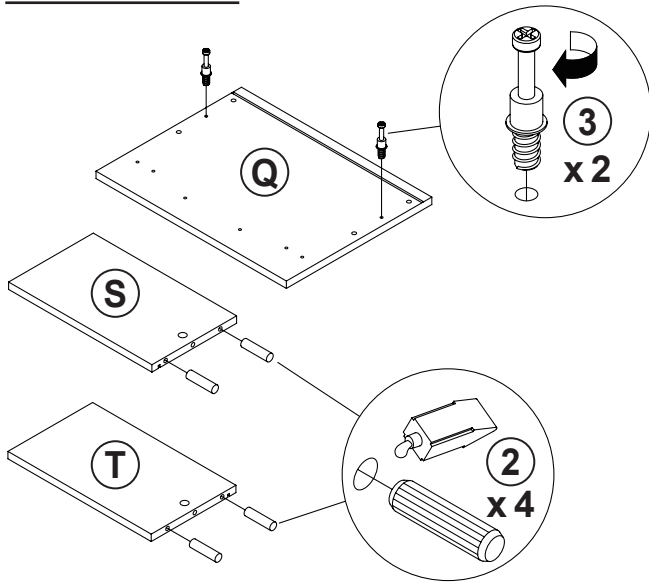

### STEP 16-2

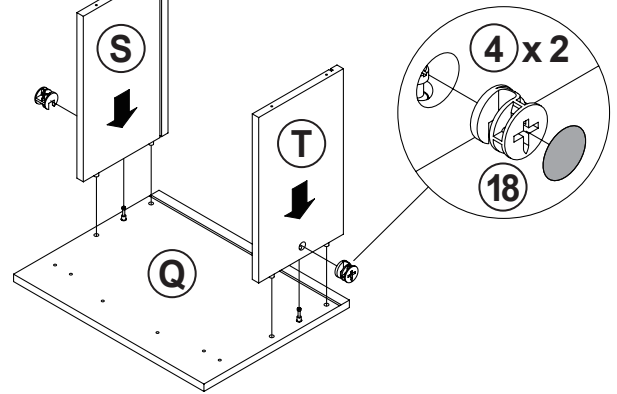

### STEP 16-3

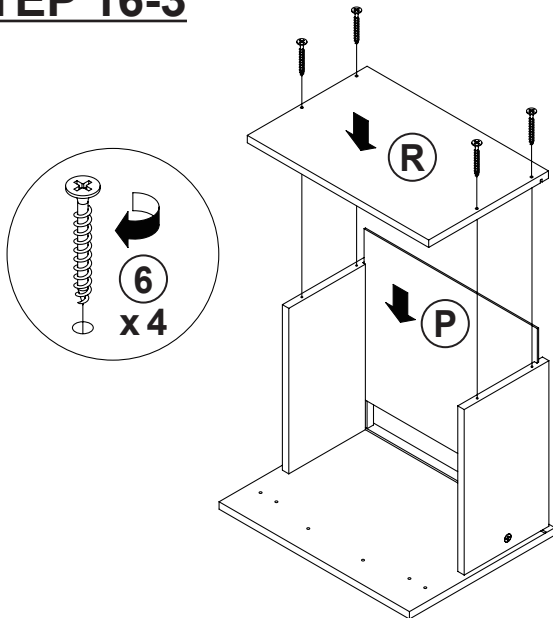

### STEP 16-4

Insert rails in outside holes for large files.  
Insert rails in inside holes for small files.

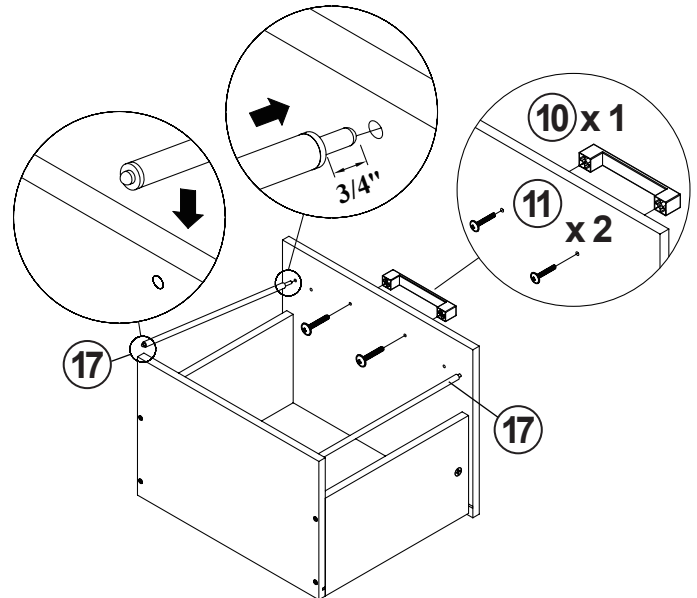

### STEP 16-5

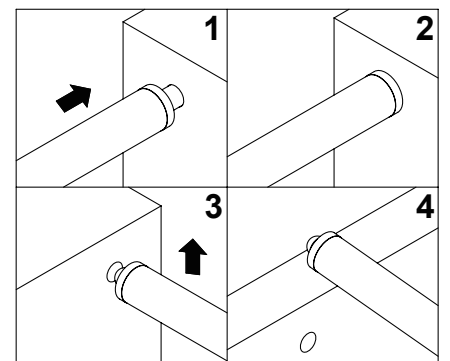
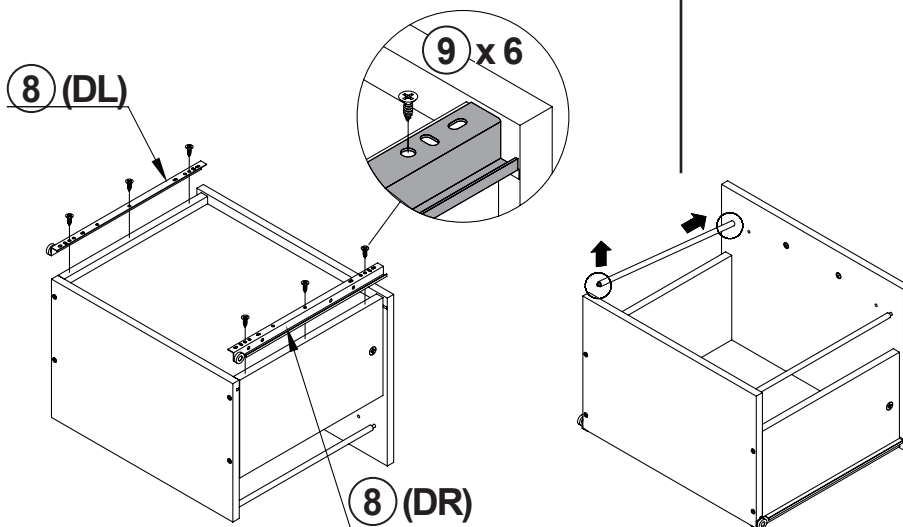

## STEP 17

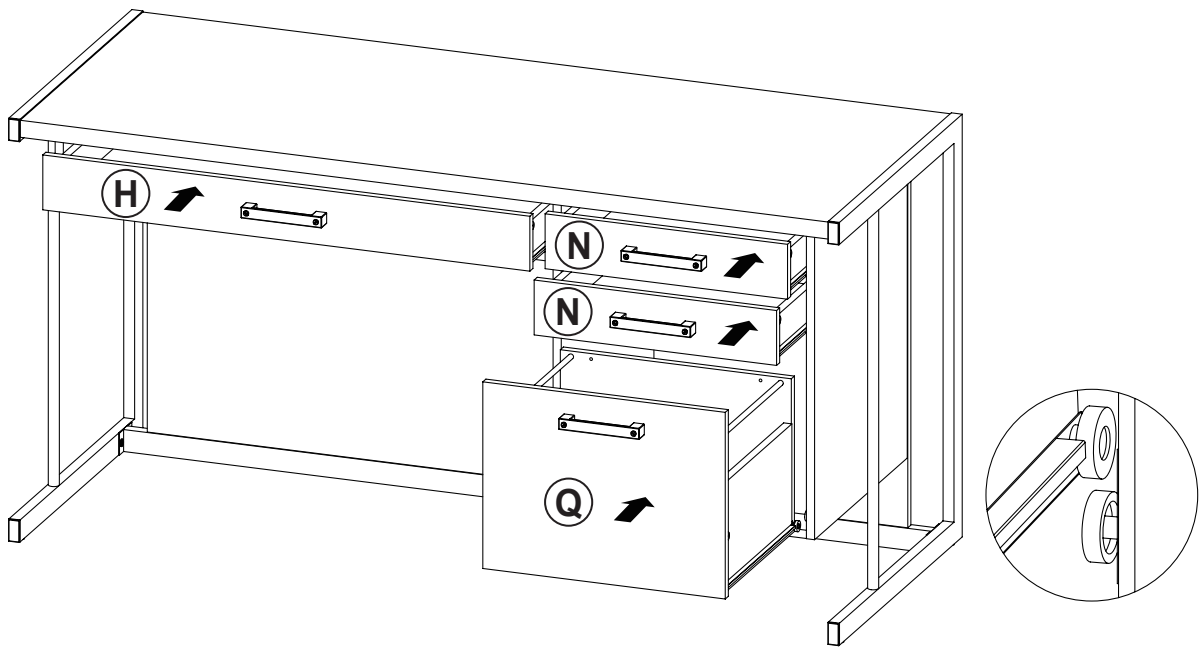

## STEP 18

COMPLETE

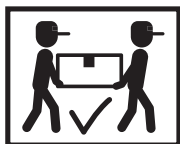
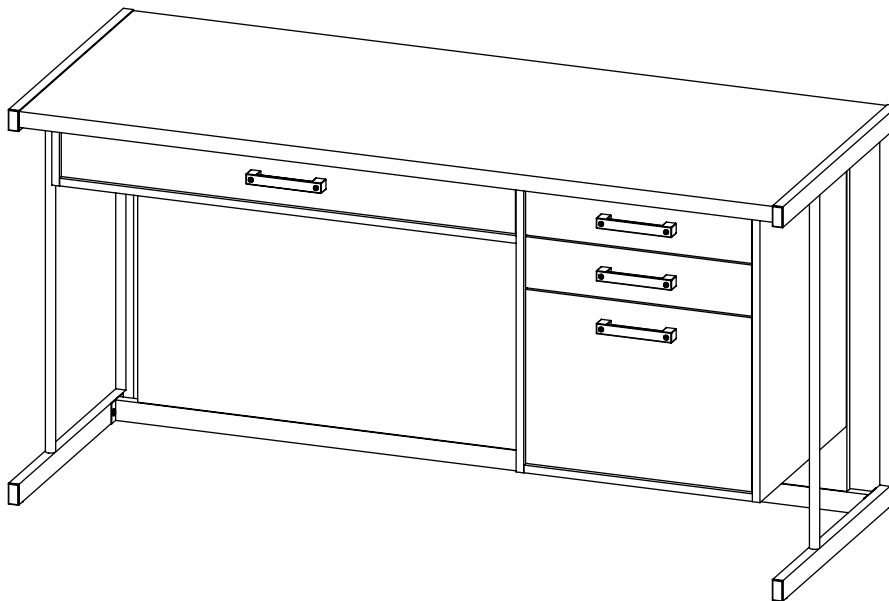

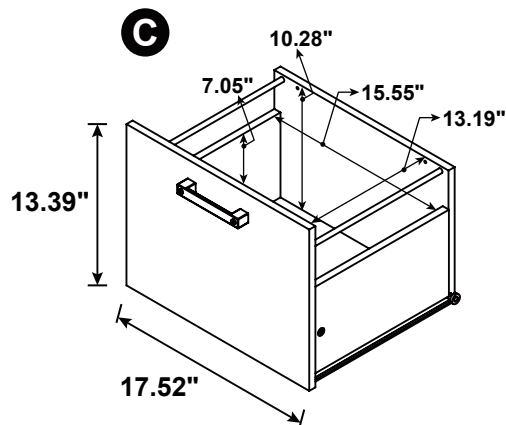
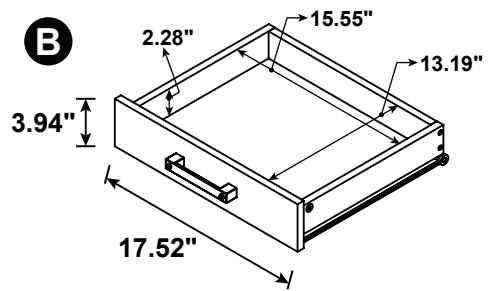
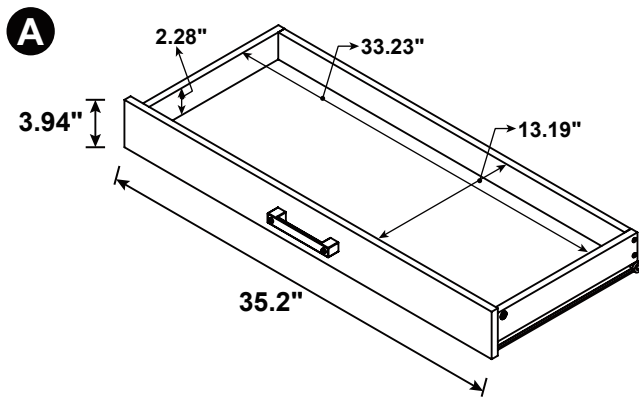
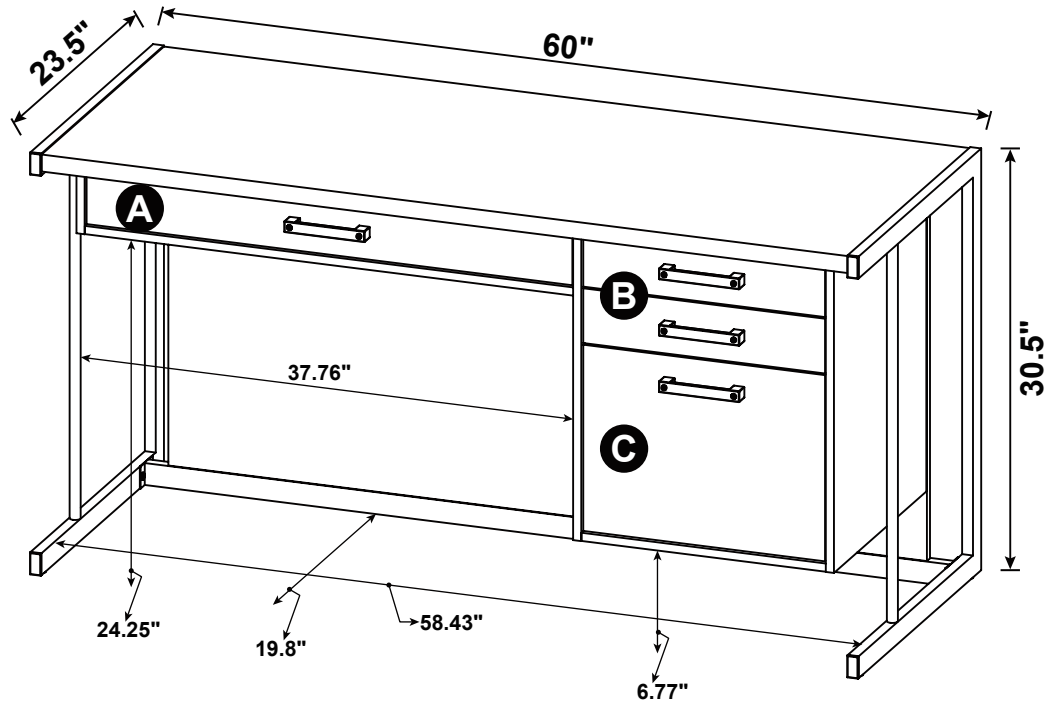

Note : Dimension tolerance  $\pm 5\%$