

# RATTAN BAR TABLE

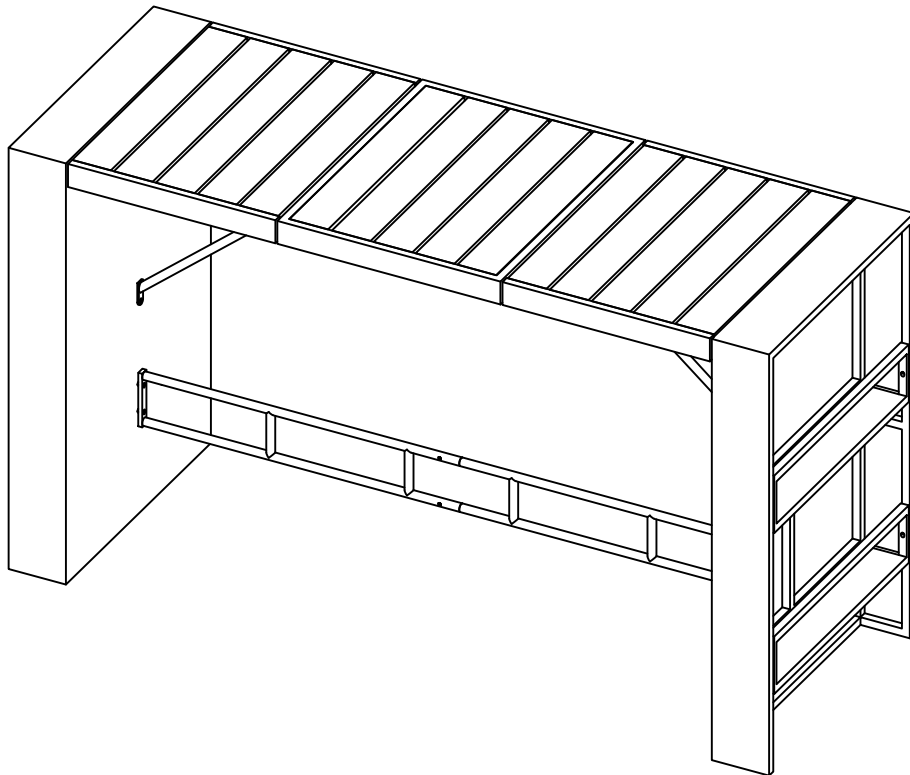







## ATTENTION Section:

1. If you encounter any issues, such as missing accessories or damaged parts, please contact us immediately and include pictures

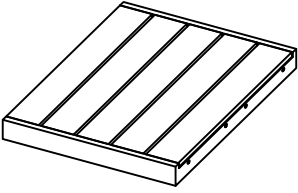
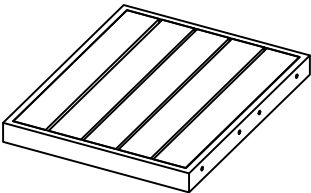
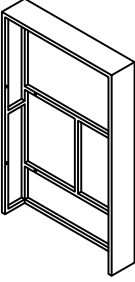
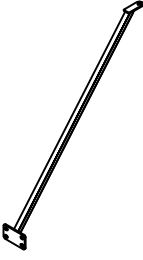
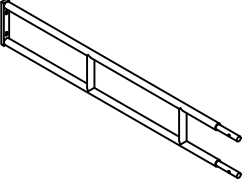
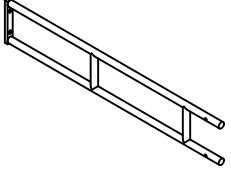
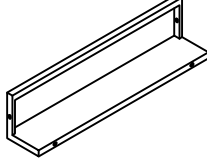
## Assembly Instructions:

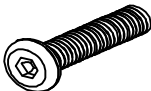
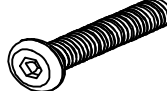
1. Assembly requires two people to complete.
2. For optimal assembly, we highly recommend using the provided Allen key.  
If using a power tool, please set it to a low speed to prevent any damage
3. Do not fully tighten the screws until all screws are properly aligned with their holes.

# PARTS LIST OF BOX

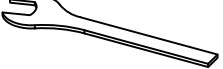
<p><b>A</b></p>  <p>2pcs</p>	<p><b>B</b></p>  <p>1pc</p>	<p><b>D</b></p>  <p>2pcs</p>	<p><b>E</b></p>  <p>2pcs</p>
<p><b>F</b></p>  <p>1pc</p>	<p><b>G</b></p>  <p>1pc</p>	<p><b>H</b></p>  <p>4pcs</p>	
<p><b>①</b></p>  <p>M6*20 10pcs</p>	<p><b>②</b></p>  <p>M6*30 22pcs</p>	<p><b>③</b></p>  <p>M6*40 12pcs</p>	<p><b>④</b></p>  <p>M6 46pcs</p>
<p><b>⑤</b></p>  <p>M6 2pcs</p>	<p><b>⑥</b></p>  <p>M6 1pc</p>	<p><b>⑦</b></p>  <p>M6 1pc</p>	

STEP 1

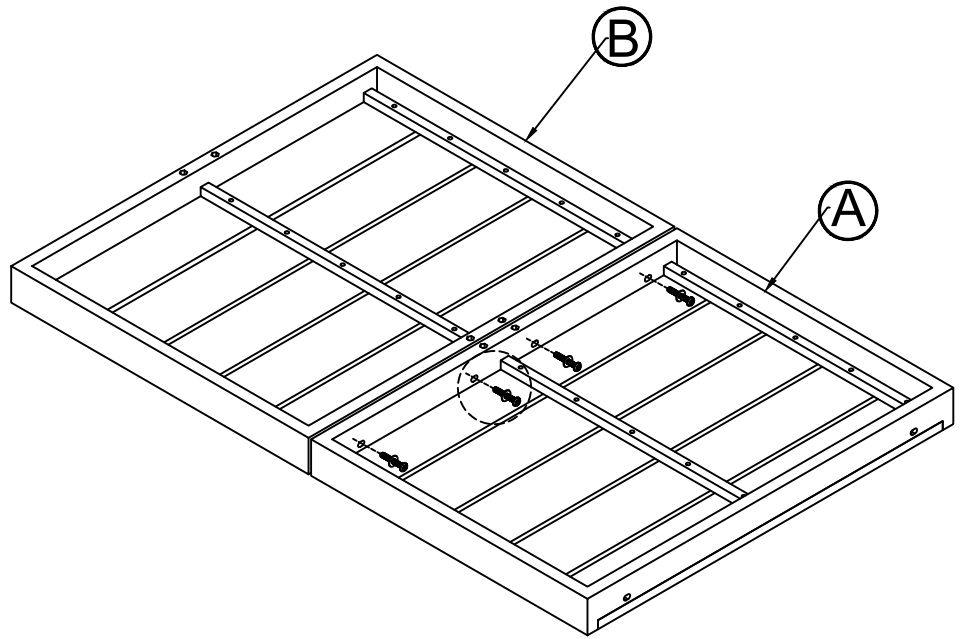
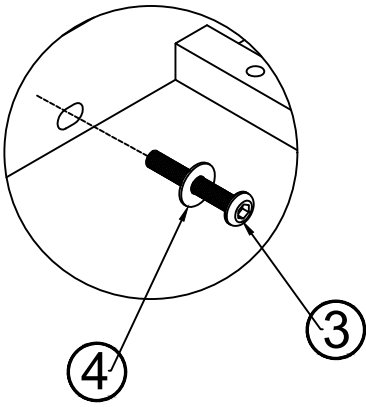

A	1pc	B	1pc	③	4pcs	④	4pcs	⑥	1pc
				M6*40		M6		M6	

STEP 2

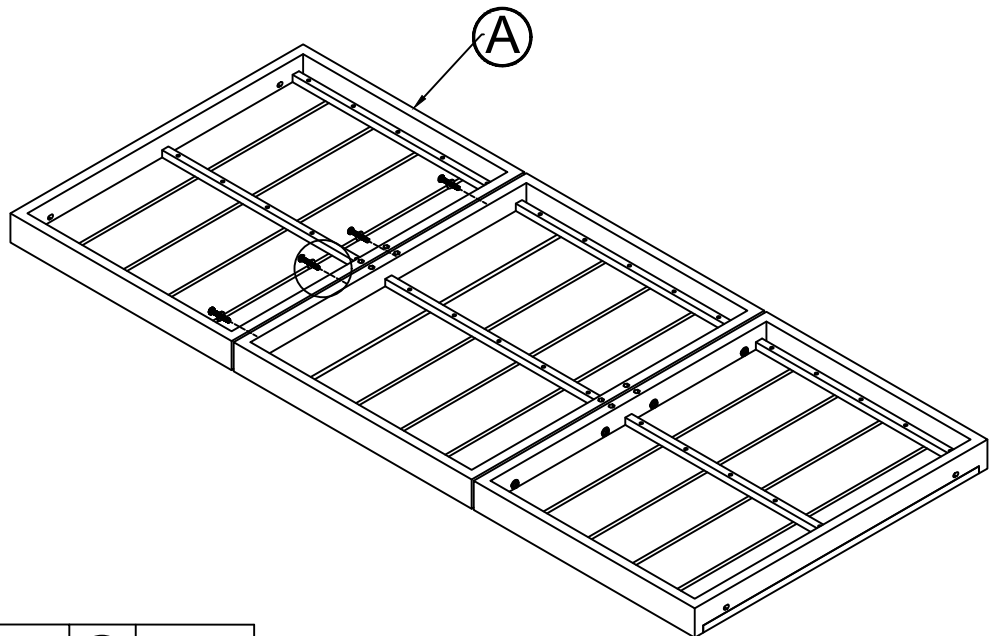
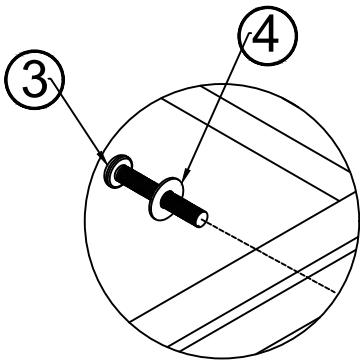



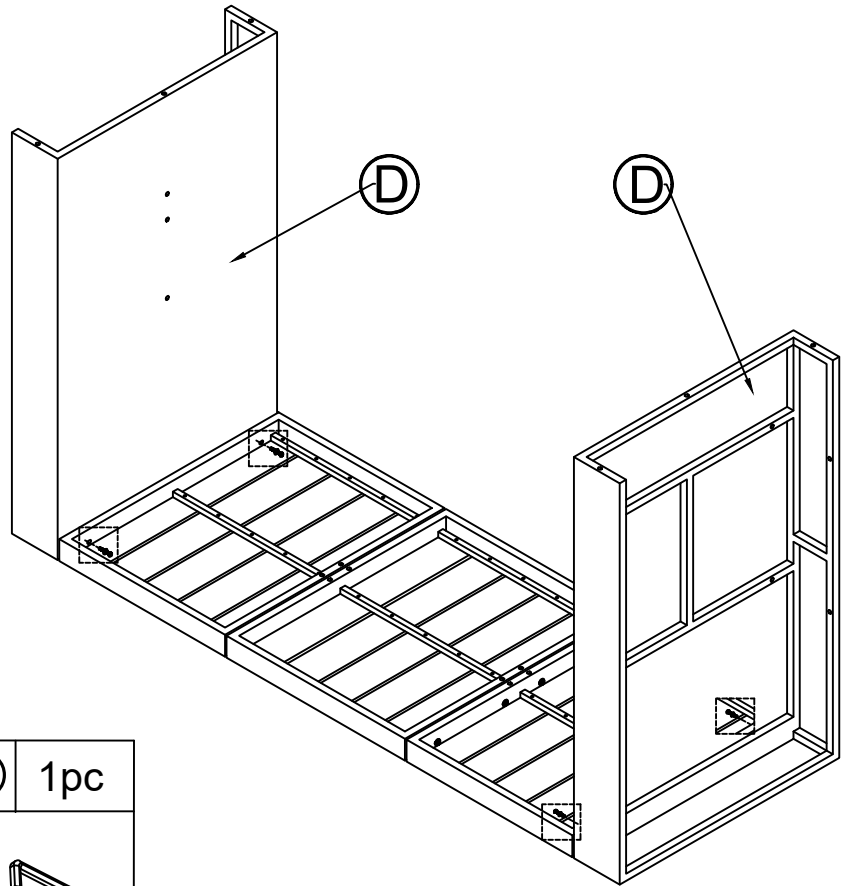
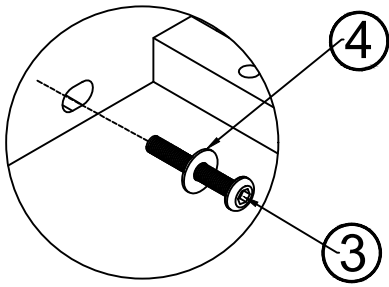

A	1pc	③	4pcs	④	4pcs	⑥	1pc
		M6*40		M6		M6	

Do not fully tighten all screws until assembly is completed.

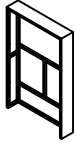



### STEP 3

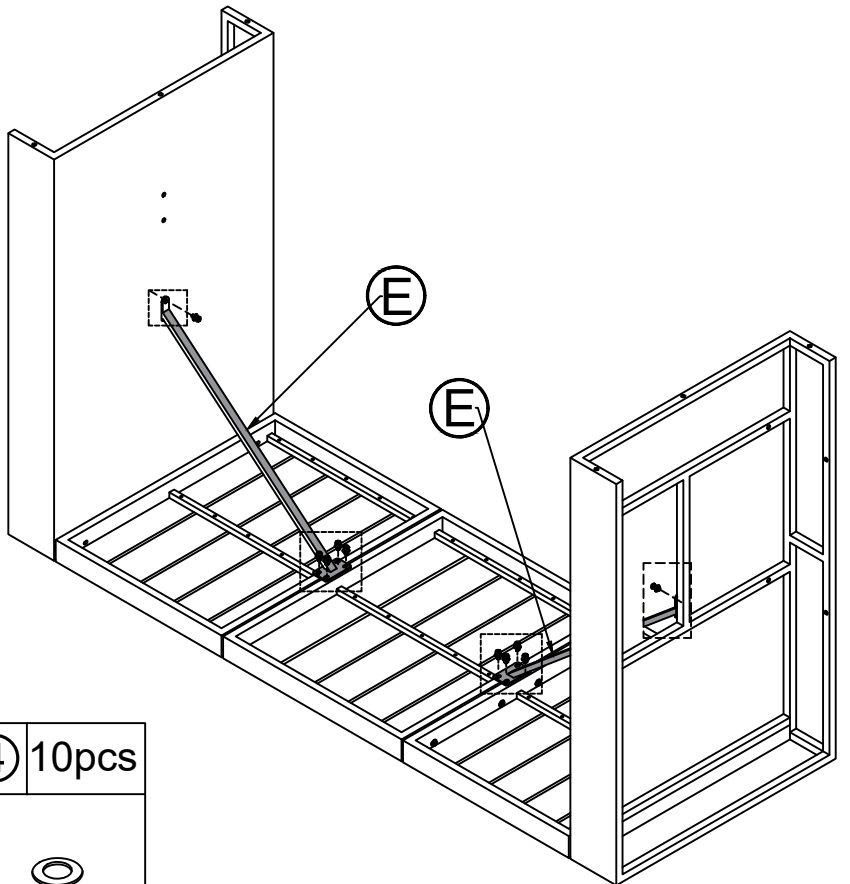
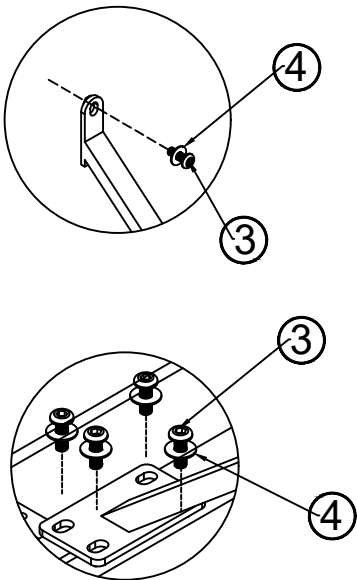

D	2pcs	③	4pcs	④	4pcs	⑥	1pc
							
		M6*40		M6		M6	

### STEP 4





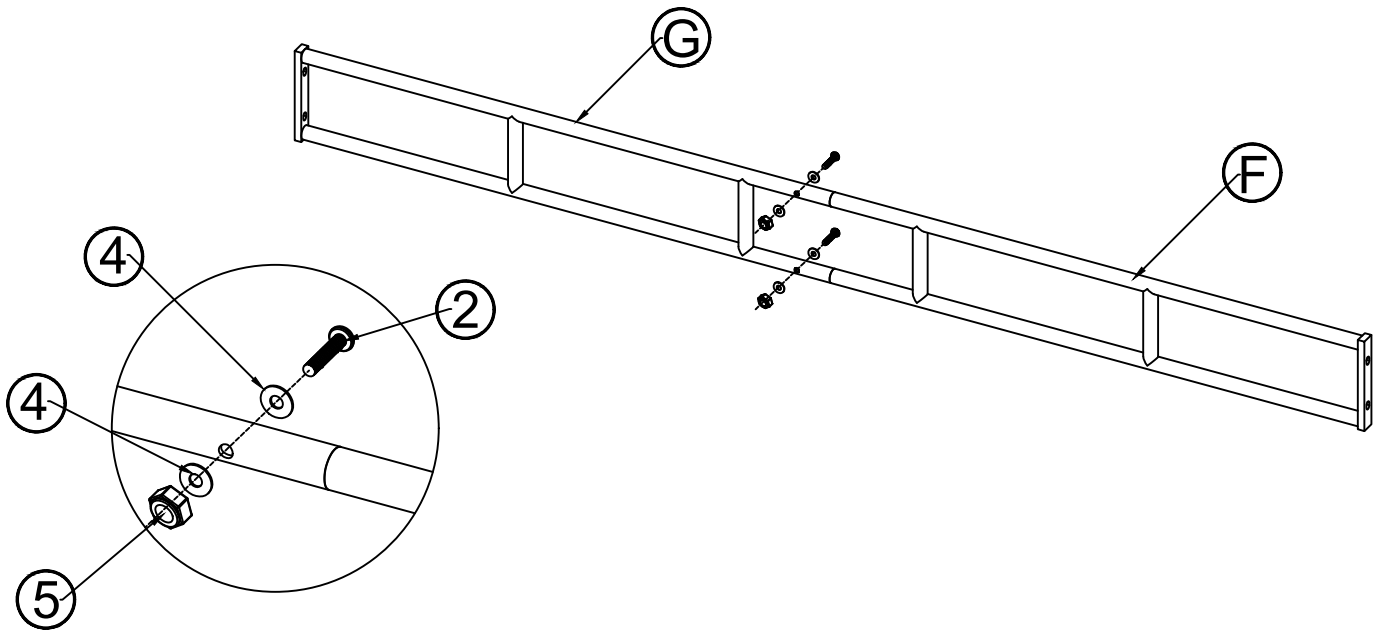

E	2pcs	①	1pc	③	10pcs	④	10pcs
							
		M6		M6*20		M6	

Do not fully tighten all screws until assembly is completed.

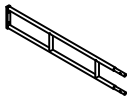
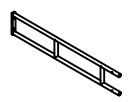

## STEP 5

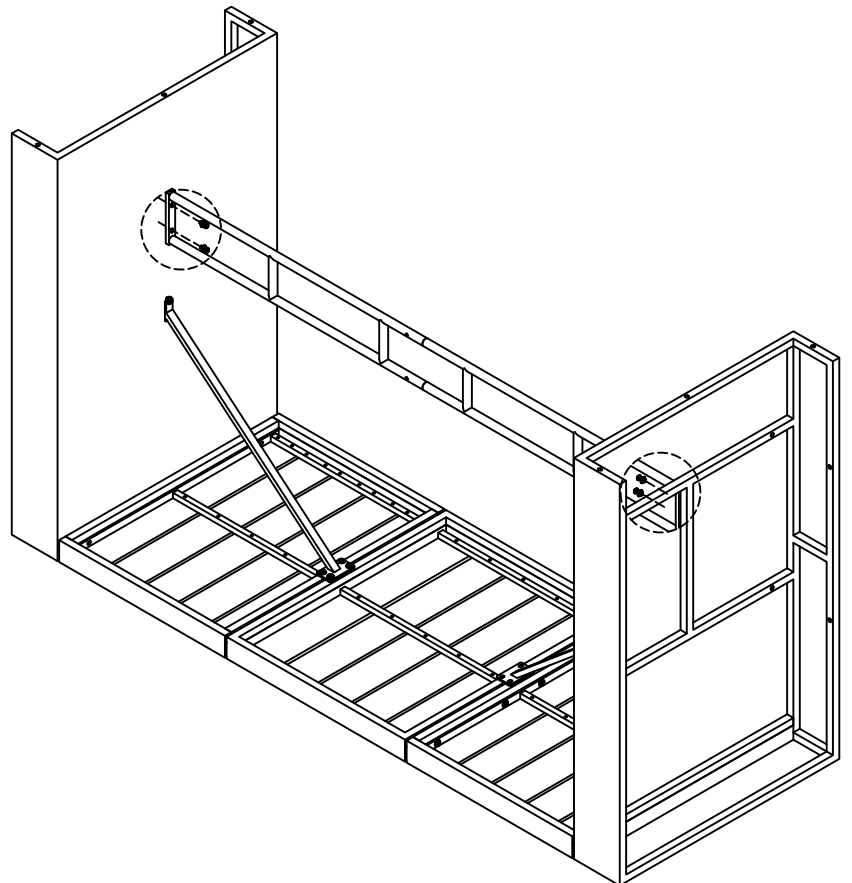
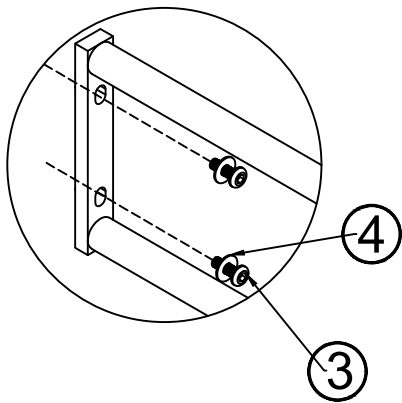

F	1pc	G	1pc	②	2pcs	④	4pcs	⑤	2pcs	⑥	1pc
											
				M6*30		M6		M6		M6	

## STEP 6



③	4pcs	④	4pcs	⑥	1pc
					
M6*30		M6		M6	

Do not fully tighten all screws until assembly is completed.

### STEP 7

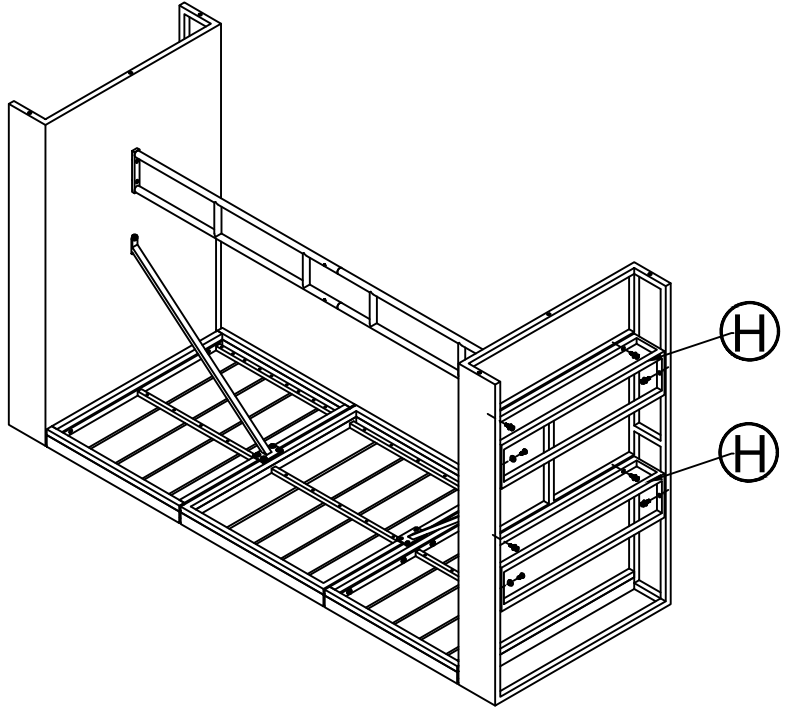
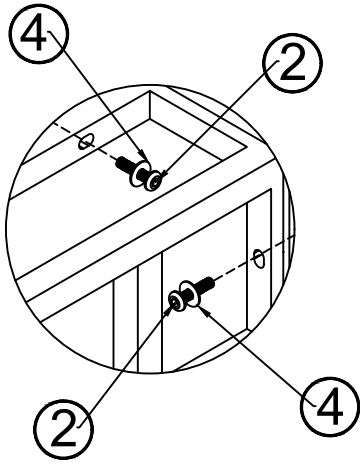

H	2pcs	②	8pcs	④	8pcs	⑥	1pc
---	------	---	------	---	------	---	-----

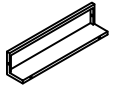

M6\*30



M6



M6

### STEP 8

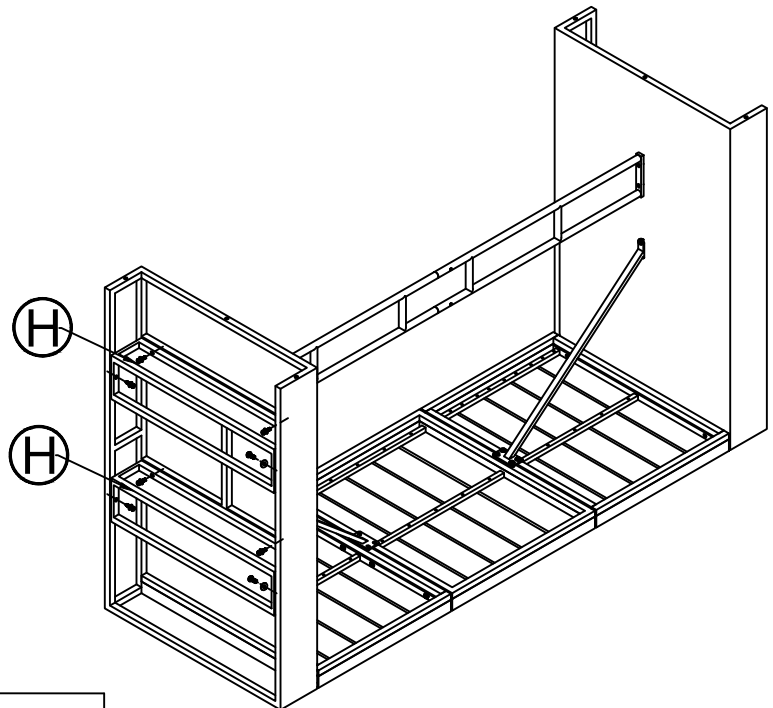
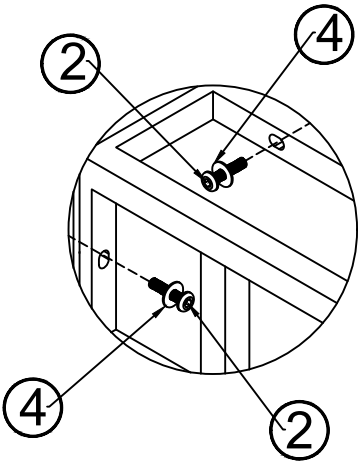

H	2pcs	②	8pcs	④	8pcs	⑥	1pc
---	------	---	------	---	------	---	-----

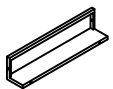

M6\*30



M6



M6

Do not fully tighten all screws until assembly is completed.