

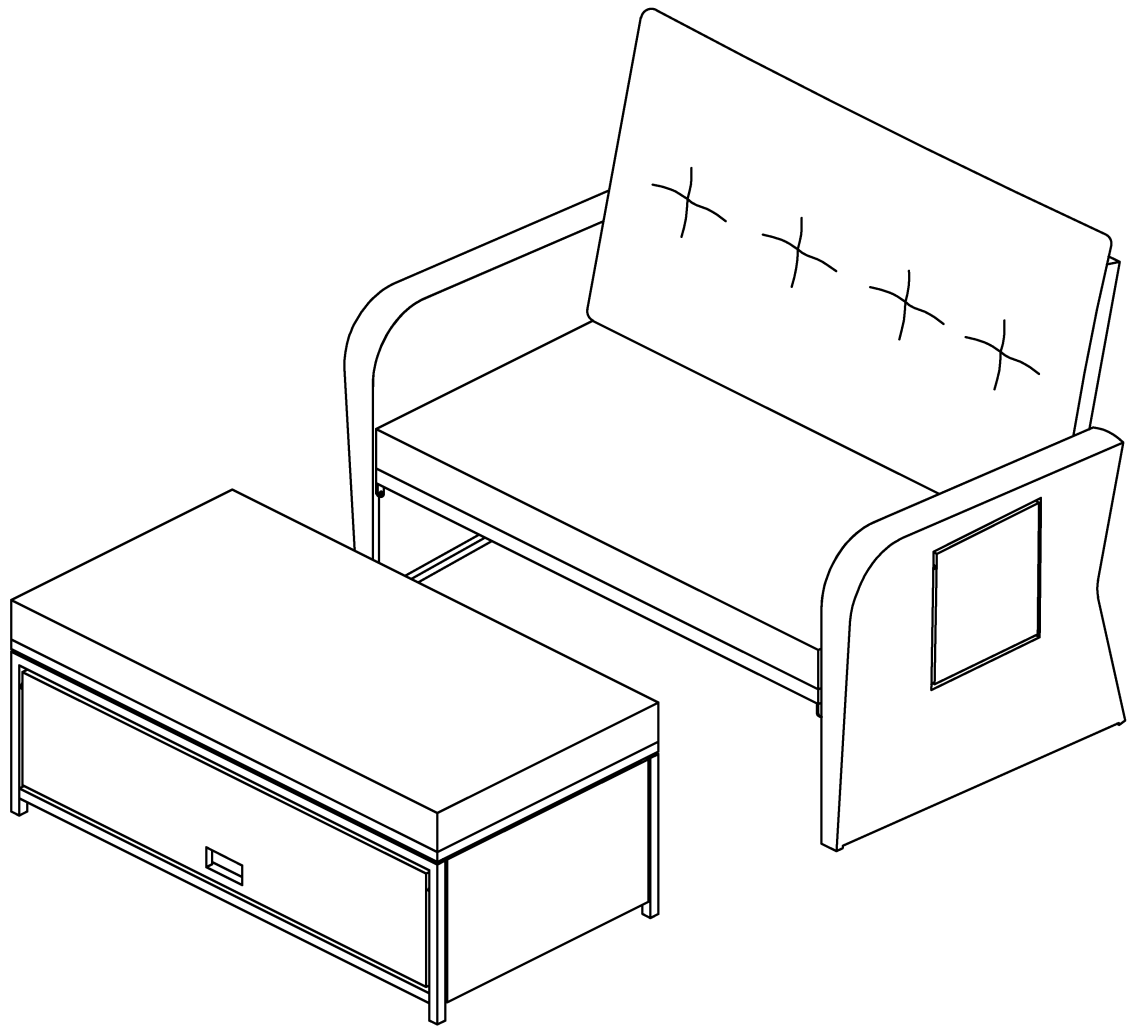

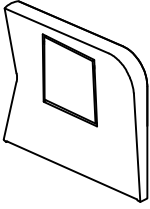

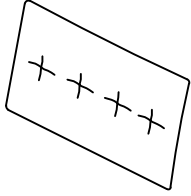

# Patio Rattan Daybed

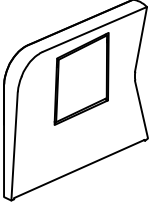
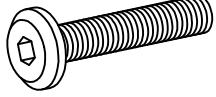
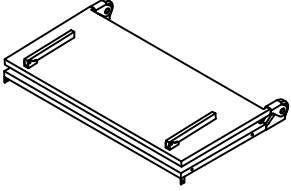
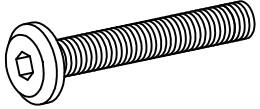
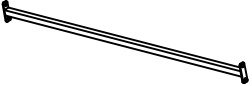
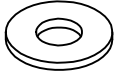
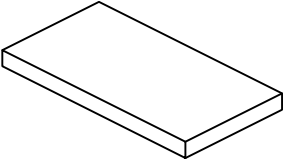

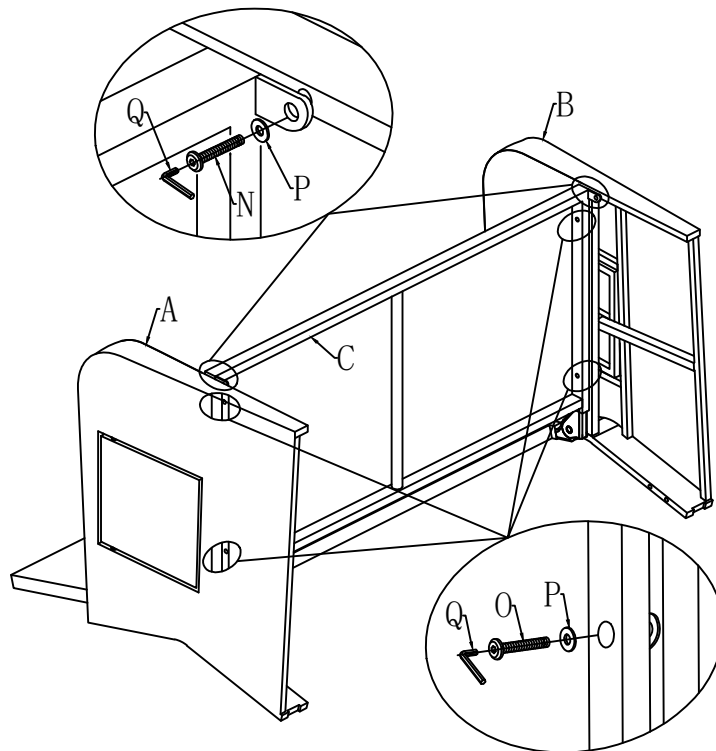
A		1	F		1
B		1	N	 M6*20mm	6
C		1	O	 M6*45mm	4
D		1	P		10
E		1	Q		1



- ① Lay the backrest down on the ground and install the armrest upright. Attach (C) to seat (A) (B) with 4pcs bolts O and 2pc bolts N and 6pcs washers P, using Allen wrench Q

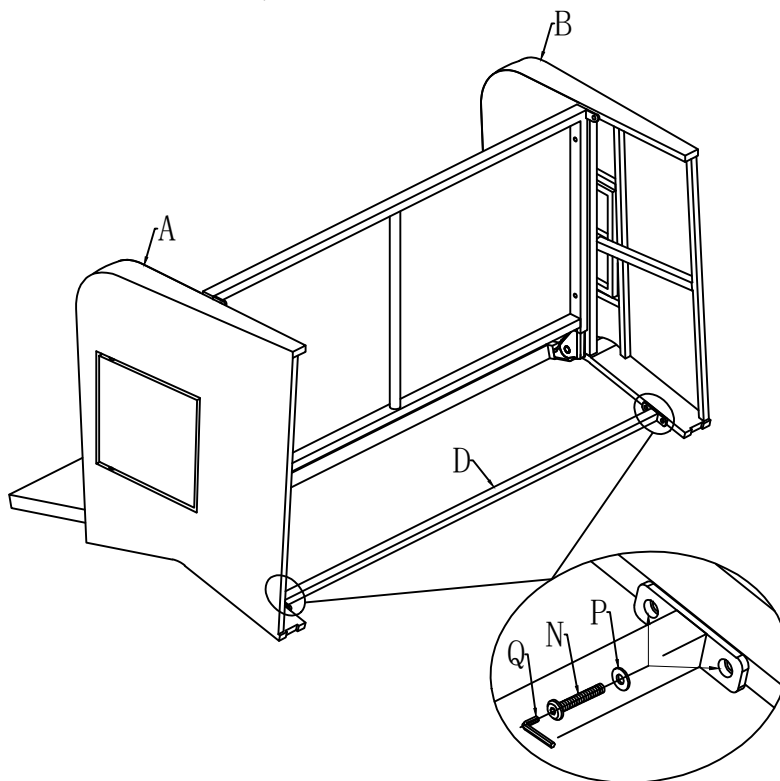

N	 M6*20mm	2
O	 M6*45mm	4
P		6

- ② Attach (D) to seat (A) (B) with 4pcs bolts N and 4pcs washers P, using Allen wrench Q



N	 M6*20mm	4
P		4

Note: Verify the alignment and adjust.  
Now fully tighten all the bolts using wrench.

③ Put cushion (E) (F)  
onto the seat

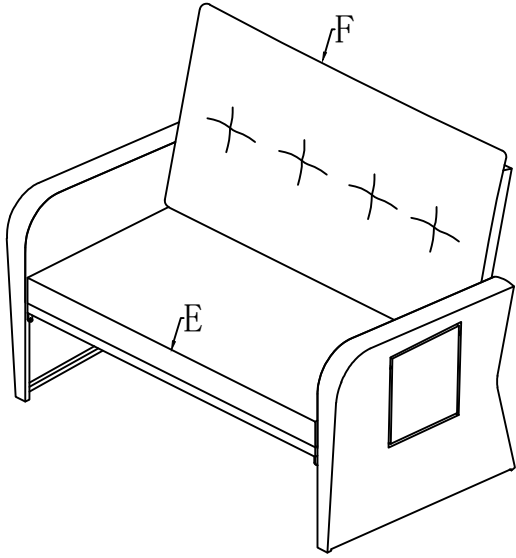

Both sides can be opened

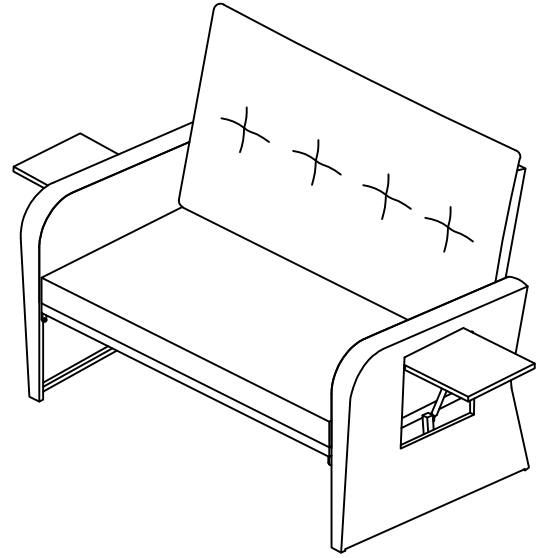

④ Open the foot tube to lay flat  
on the back

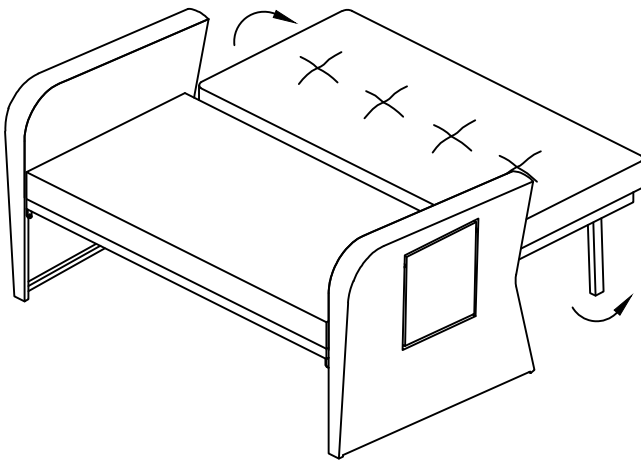

Fold the back and rotate the  
support tube

