

Installation & Assembly

Arched Bookcase

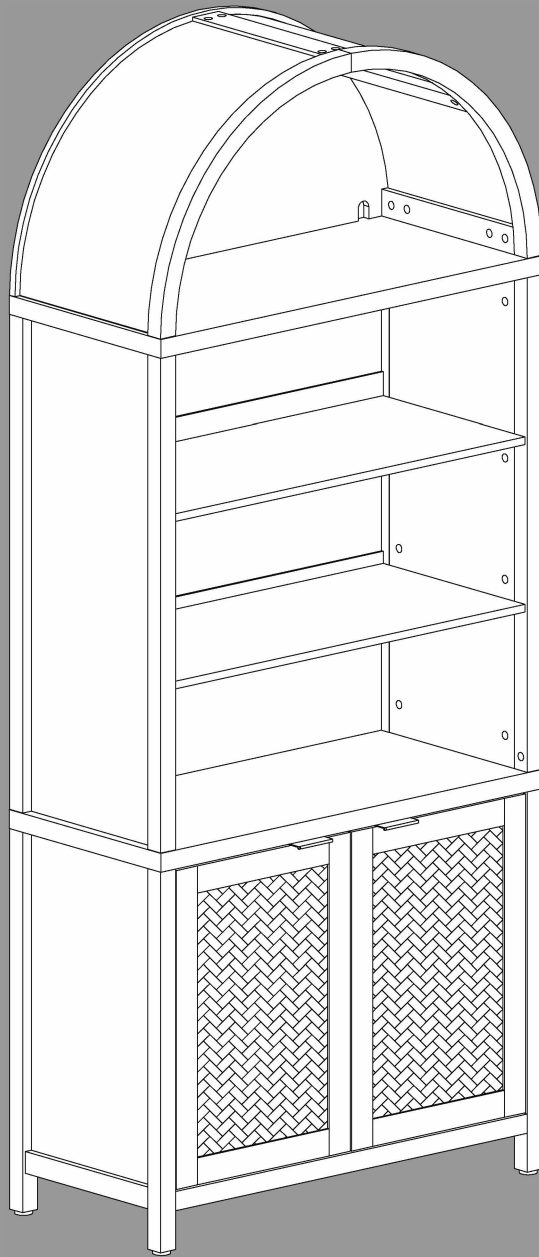

Assembly Instructions

Before beginning the assembly process, please read and save these instructions for reference.

Following these guidelines will ensure a smooth and successful assembly of your product.

1. Part Identification:

Carefully separate and identify all the parts included in your package. Confirm that you have all the components listed in the instruction manual. This step will help you avoid any missing or misplaced parts during assembly.

2. Work Surface:

To prevent any scratches or damage to the product, assemble it on a soft mat or a similar protective surface. This will provide a cushioned area for the components and protect the surfaces from unwanted marks.

3. Step-by-Step Assembly:

Follow the assembly instructions provided, proceeding one step at a time. Take care to understand each step properly before proceeding to the next one. This sequential approach ensures that the assembly is done correctly and minimizes the chance of errors.

4. Proper Screw Seating:

When attaching screws and nuts, it is essential not to fully tighten them until all screws are correctly seated. By partially tightening each screw and nut initially, you can ensure that they are aligned properly and fit securely before final tightening.

5. Avoid Over-Tightening:

While each screw and nut should be tightened correctly, it is crucial not to over-tighten them. Over-tightening can cause damage to the product or compromise its structural integrity. Use the appropriate amount of force to secure the components without excessive tightening.

SICOTAS customer help center:

If you encounter any questions or problems during the assembly process, please do not hesitate to contact us.

We strive to provide excellent customer support and will respond to your inquiries within 24 hours. Our team will offer you a suitable solution to address any concerns you may have.

Parts List

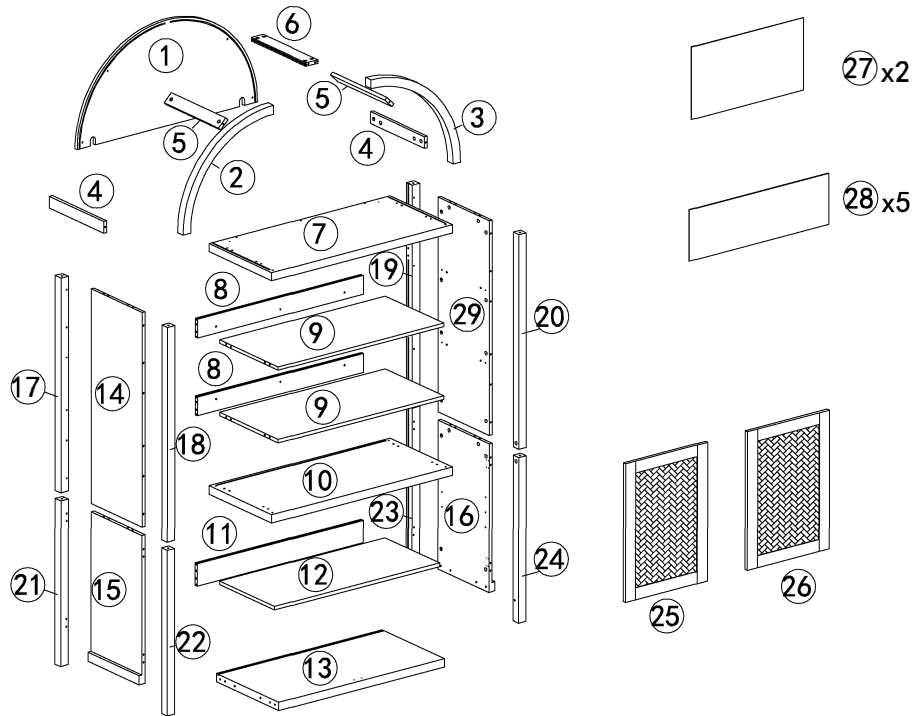

Hardware List

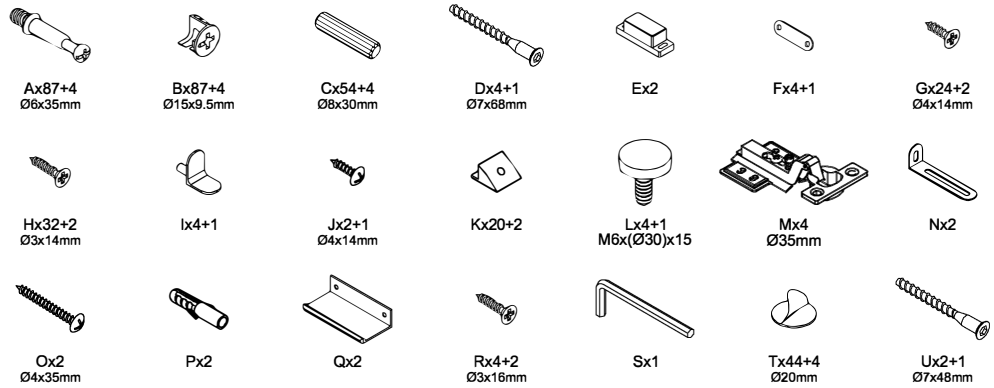

Code	Description	Quantity
A	M6*35mm Cam bolt	87+4
B	Ø15x9.5mm Cam lock	87+4
C	Ø6x30mm Wood dowel	54+4
D	Ø7*68 Broken tall screw	4+1
E	Magnet	2
F	Magnet plate	4+1
G	Ø4x14 Self-tapping screw	24+2
H	Ø3x14 Self-tapping screw	32+2
I	Shelf support	4+1
J	Ø4x14 Broken tail screw	2+1
K	Back clip	20+2

Code	Description	Quantity
L	M6x(Ø30)x15 Adjustable foot	4+1
M	Hinge	4
N	Anti falling iron sheet	2
O	Ø4x35 Broken tail screw	2
P	Plastic expansion screw	2
Q	Handle	2
R	Ø3x16 Self-tapping screw	4+2
S	Hexagon socket wrench	1
T	Ø30 Hole stickers	44+4
U	Ø7*48 Broken tall screw	2+1

Step 1

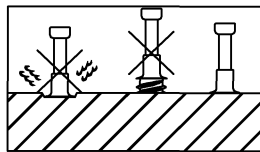
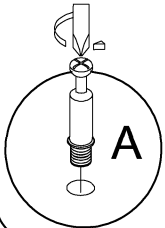
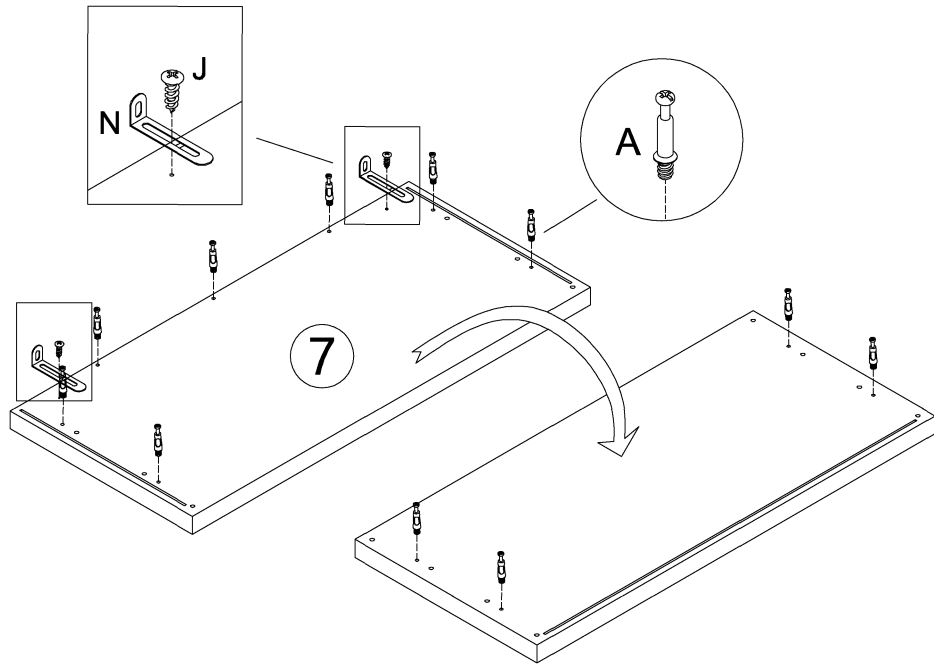

A*11	J*2	N*2

Step 2

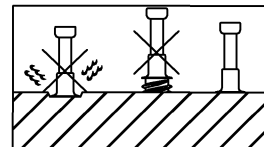
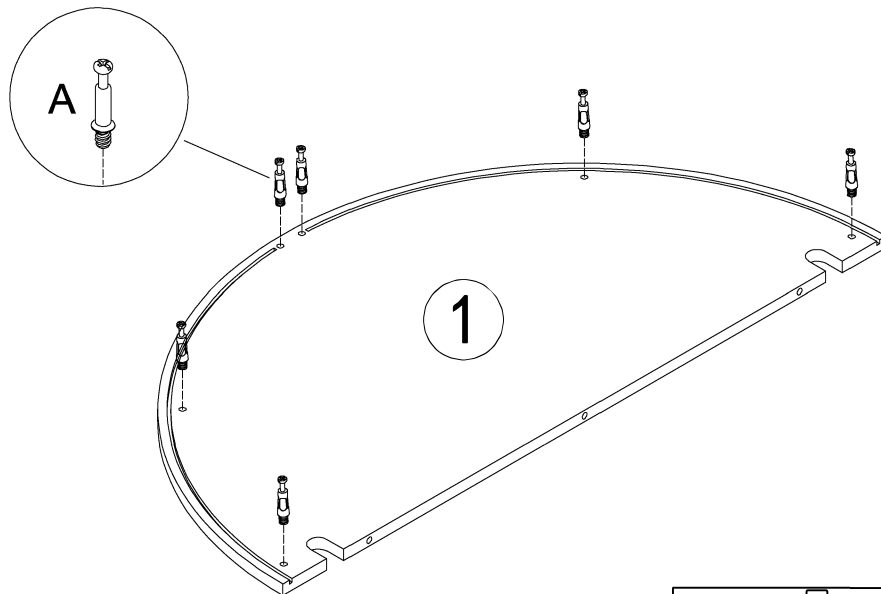

A*6

Step 3

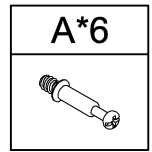
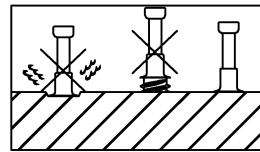
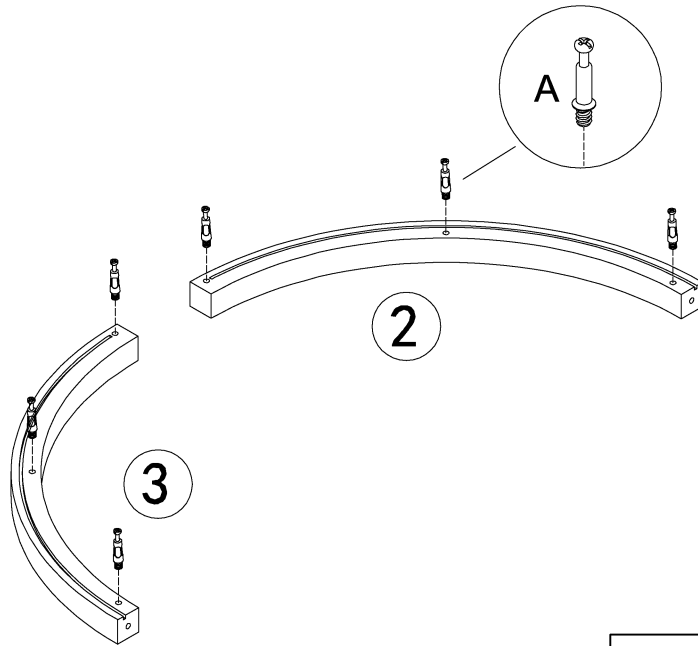

Step 4

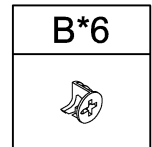
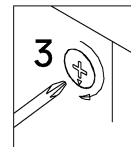
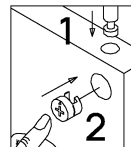
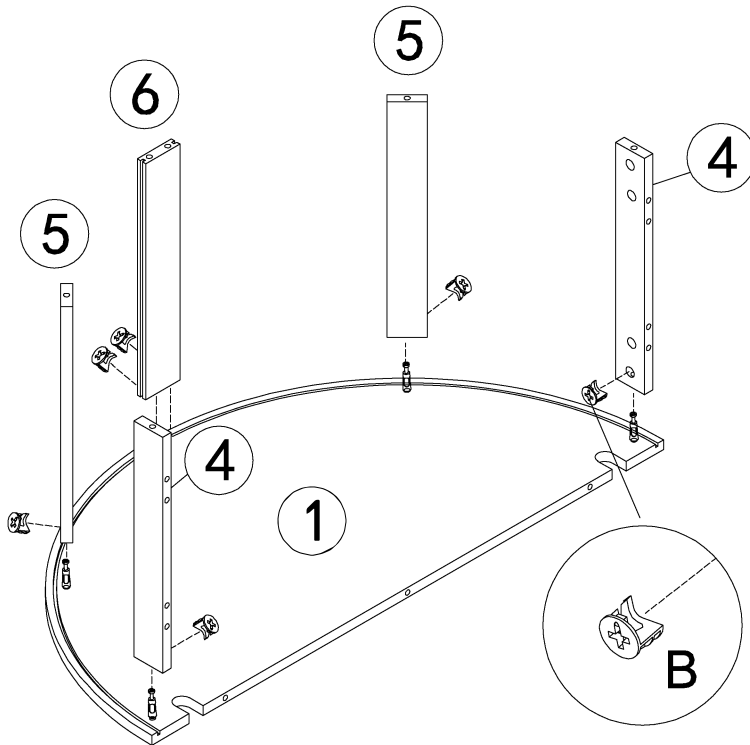

Step 5

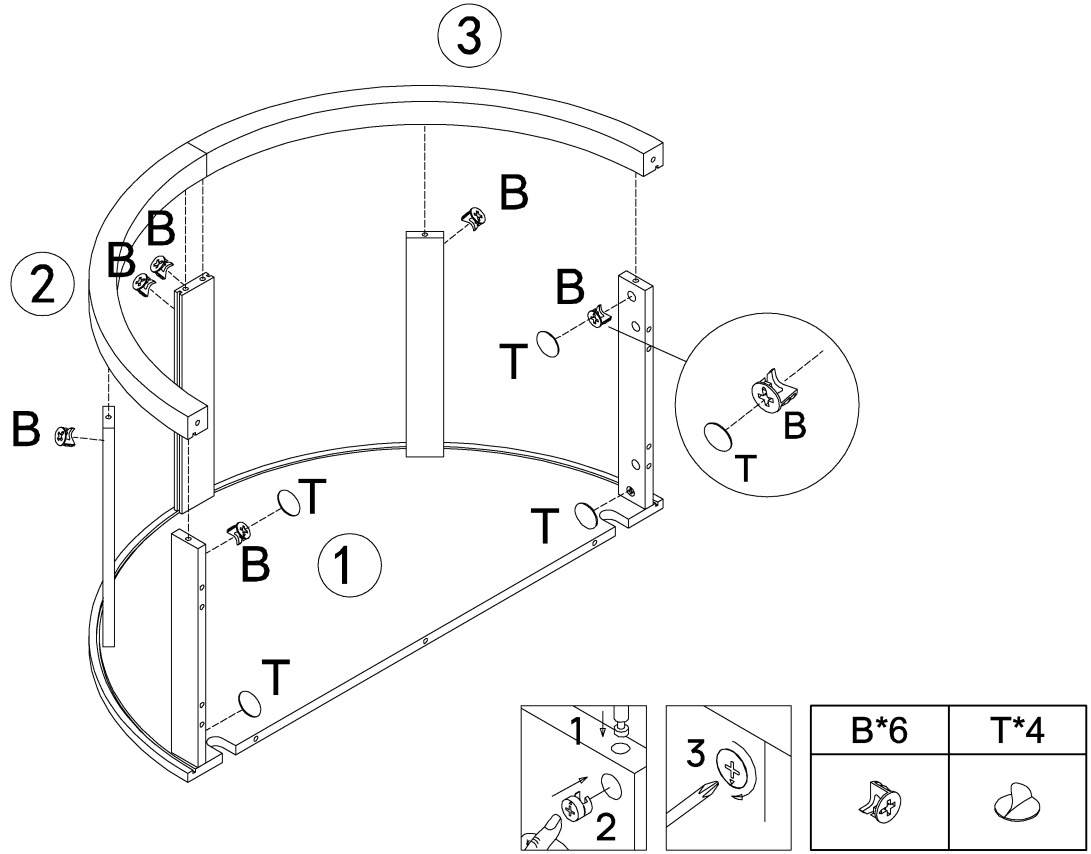

Step 6

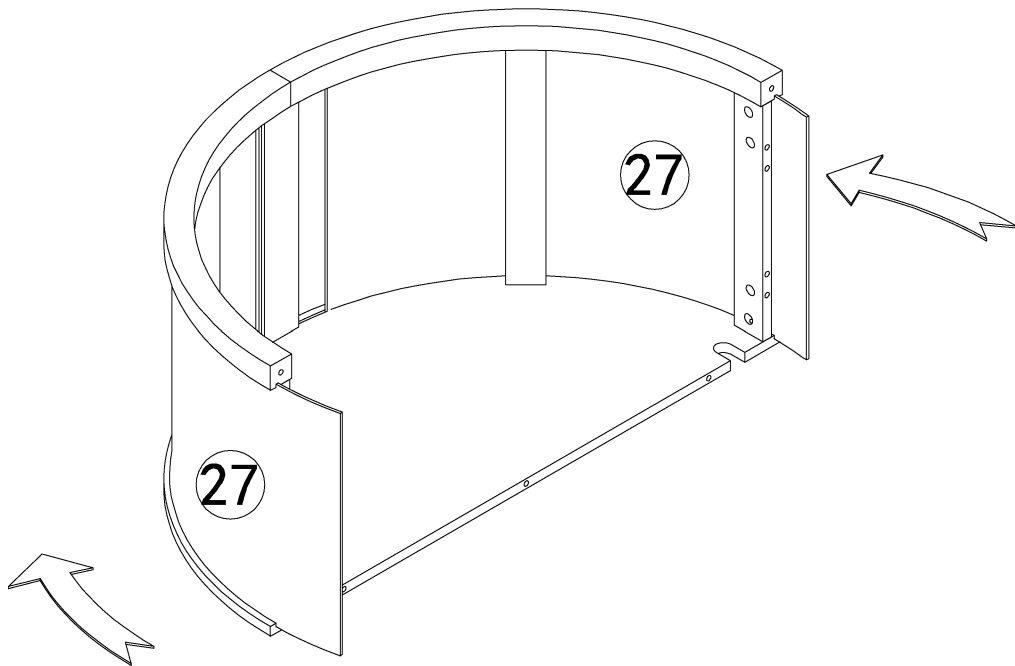

Step 7

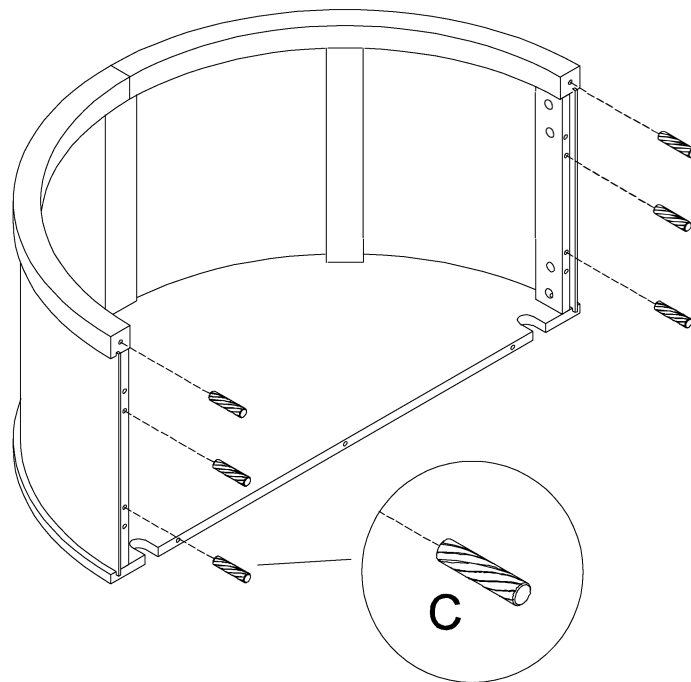

C*6

Step 8

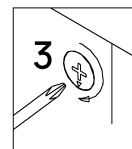
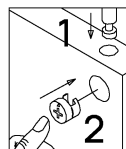
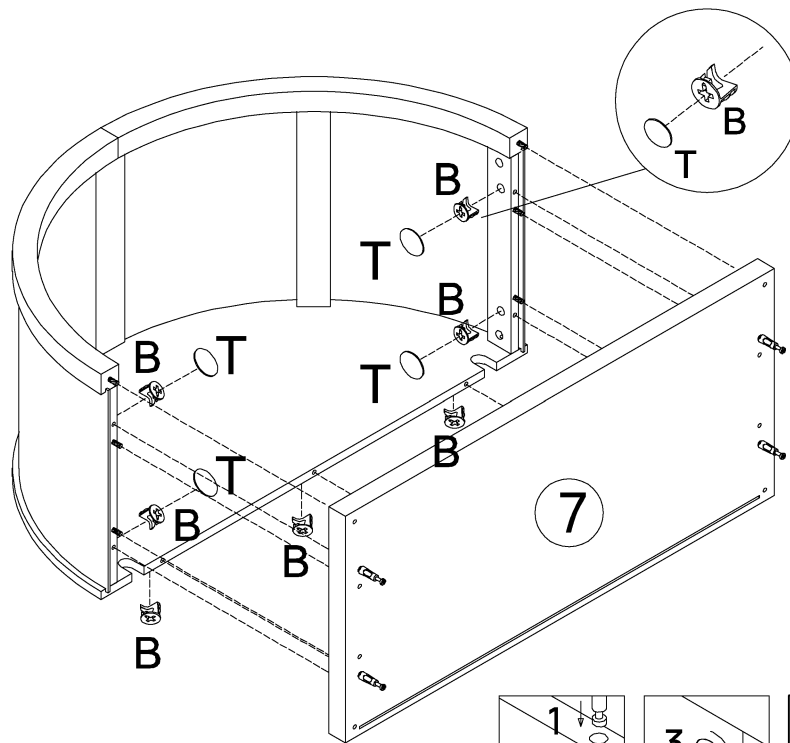

B*7	T*4

Step 9

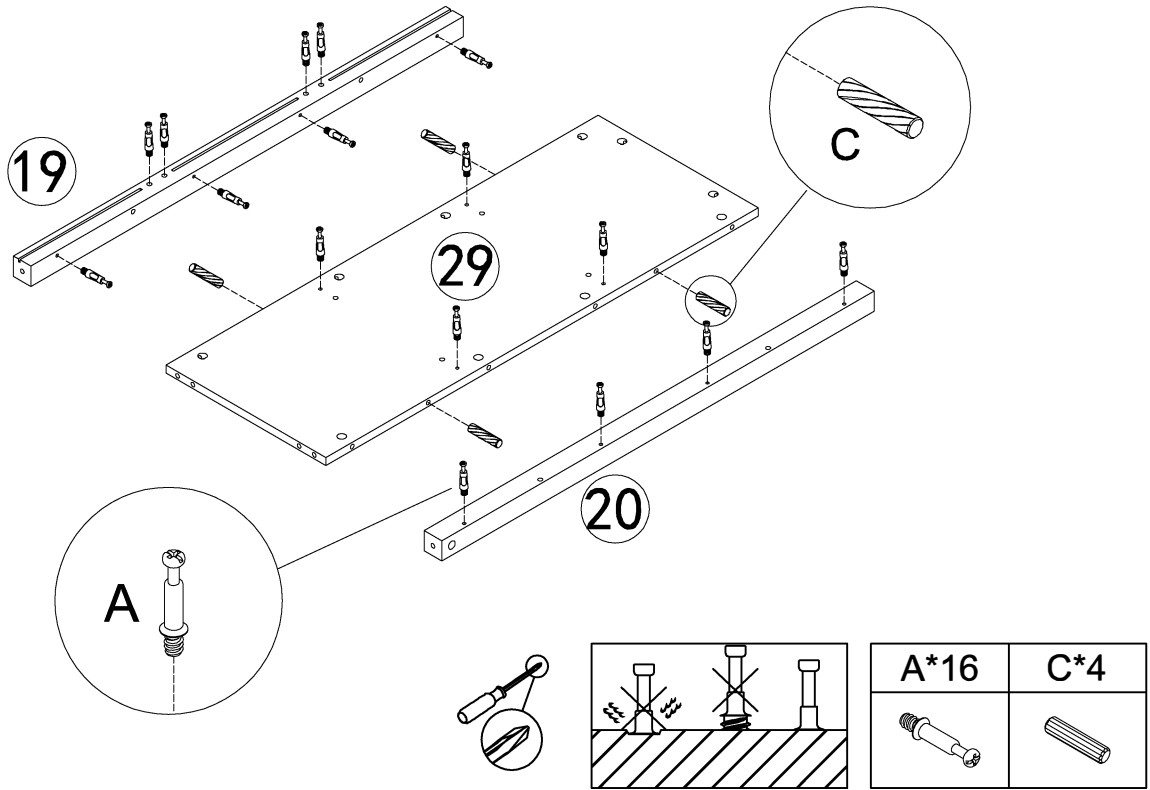

Step 10

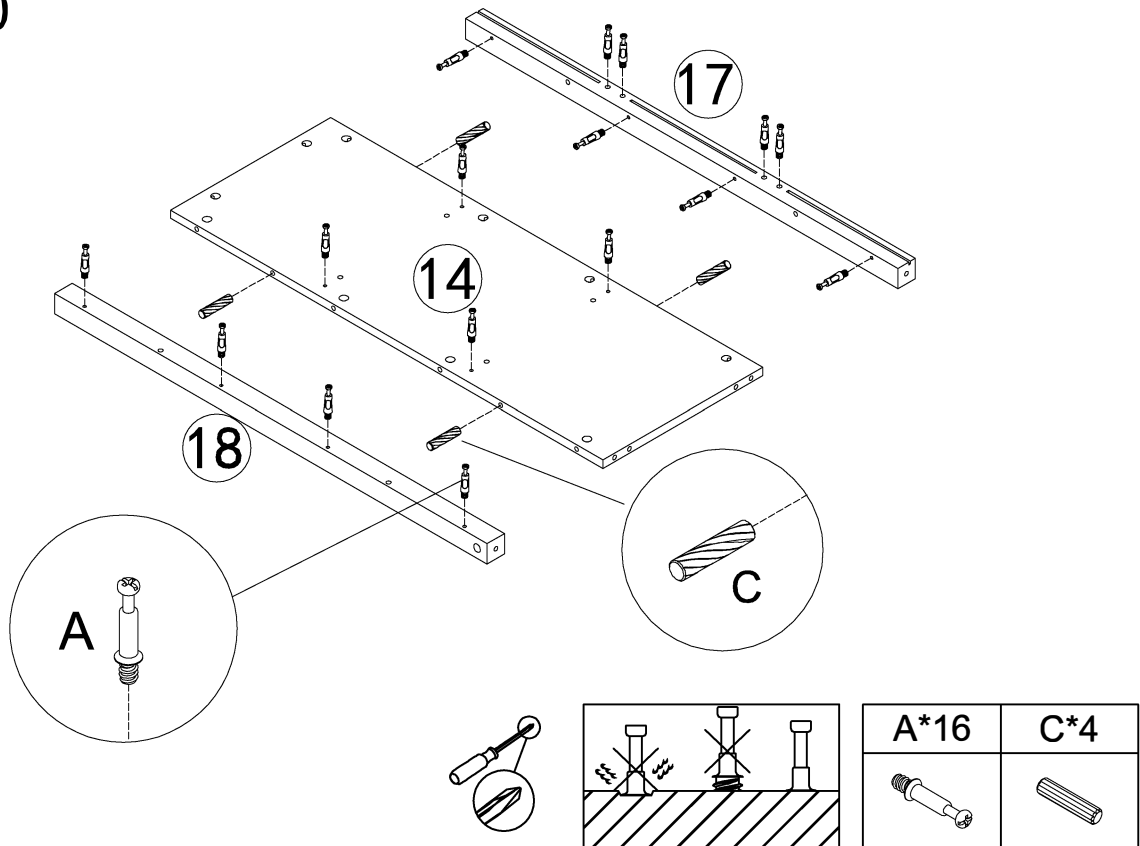

Step 11

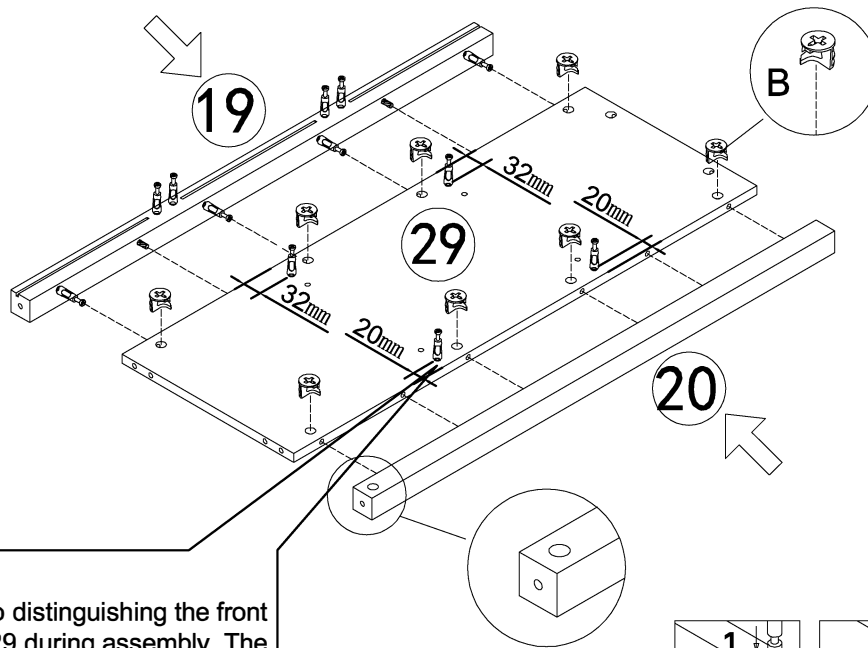

Note:

Pay attention to distinguishing the front and back of part 29 during assembly. The edge with the smaller distance to cambolt should be assembled with part 20.

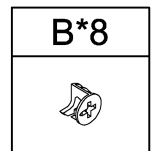
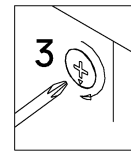
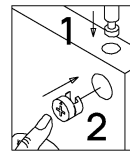

Step 12

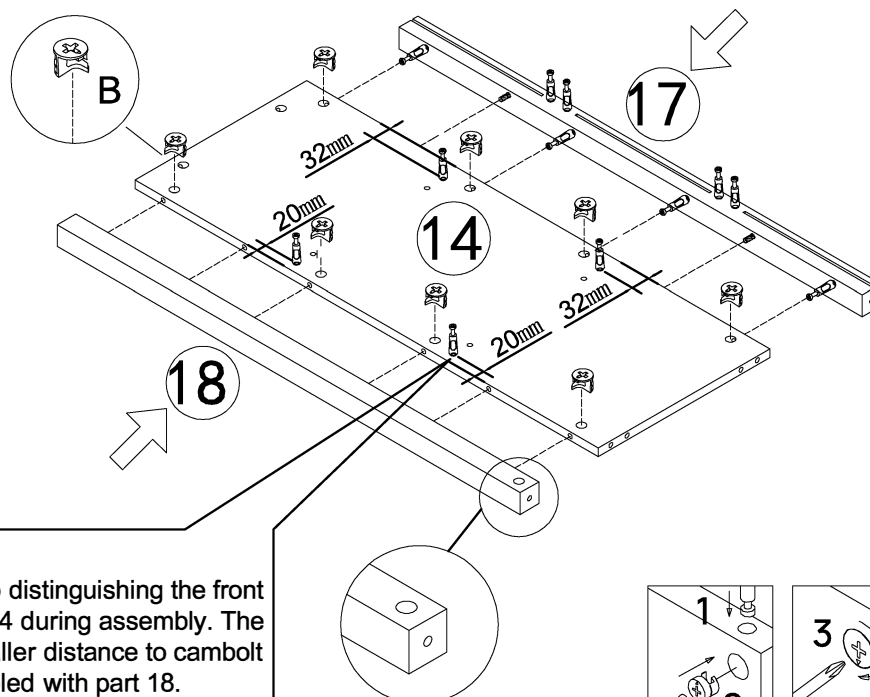



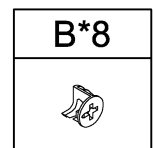
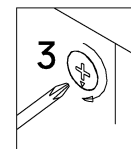
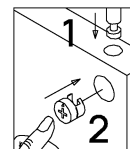

Note:

Pay attention to distinguishing the front and back of part 14 during assembly. The edge with the smaller distance to cambolt should be assembled with part 18.

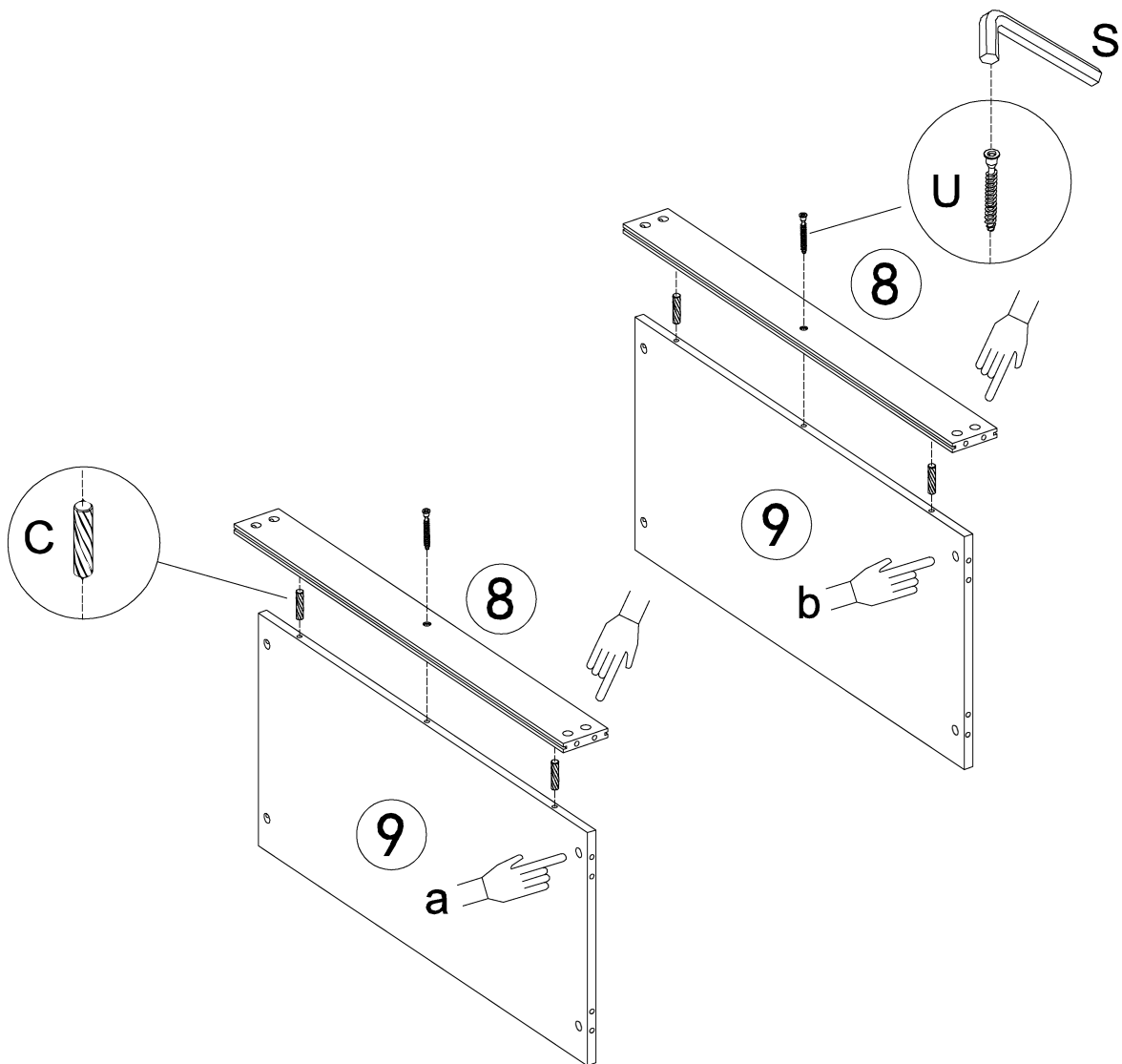
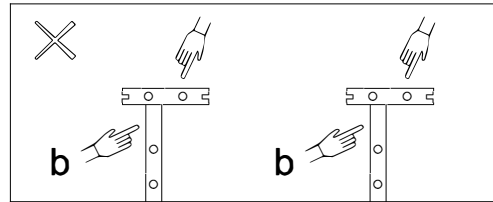
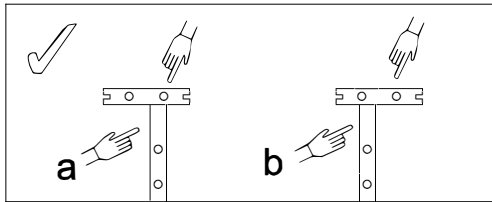

Step 13



S*1	C*4	U*2
		

Step 14

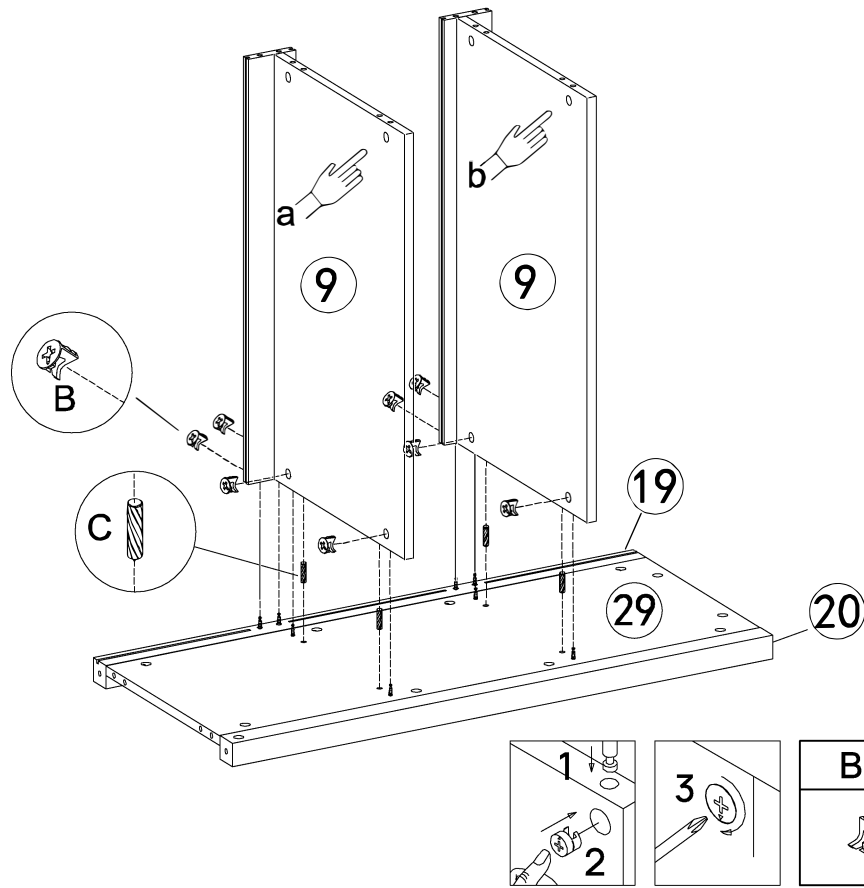

Step 15

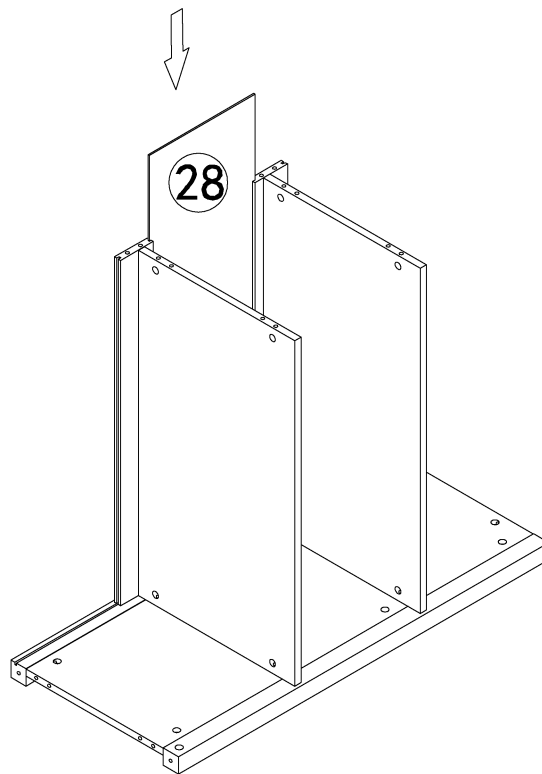

Step 16

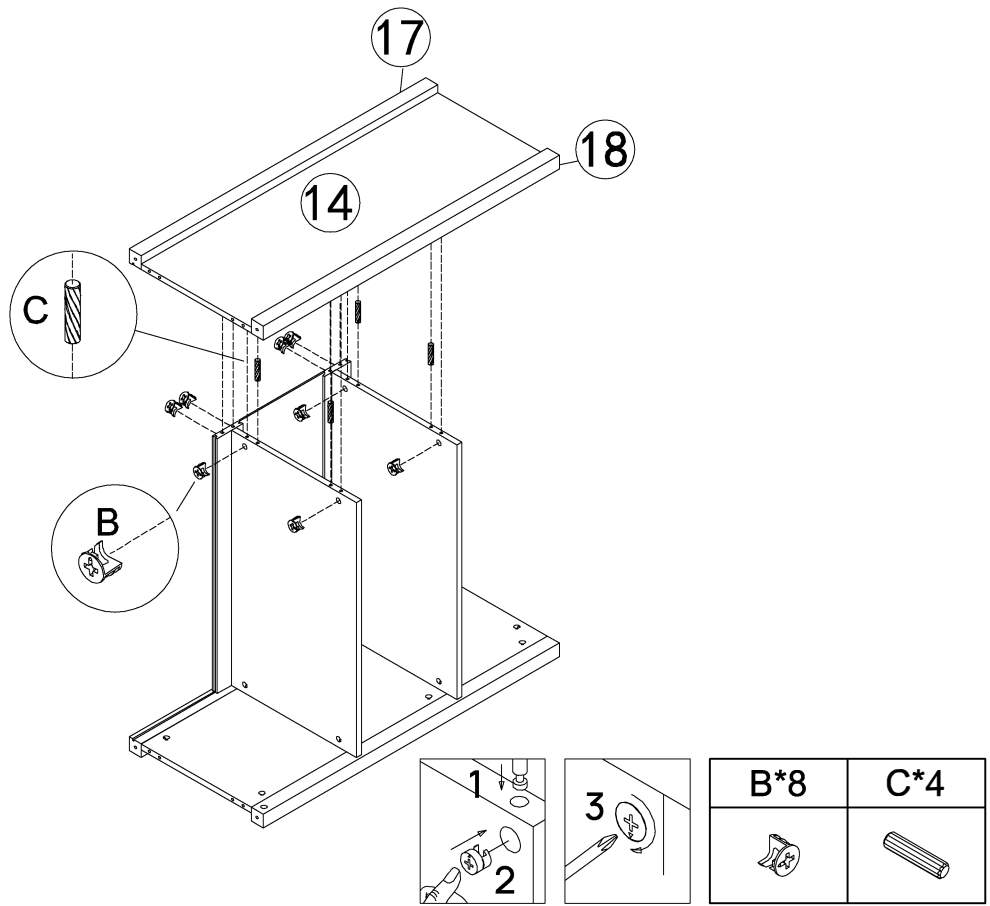

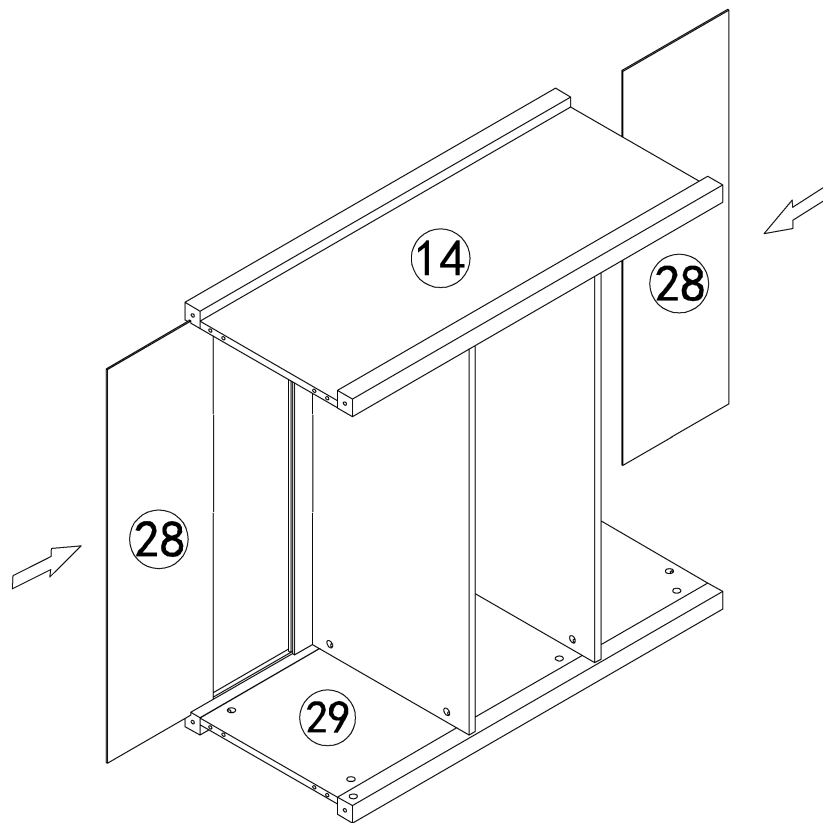

Step 17



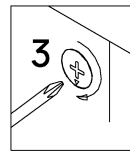
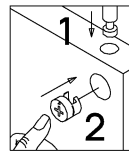
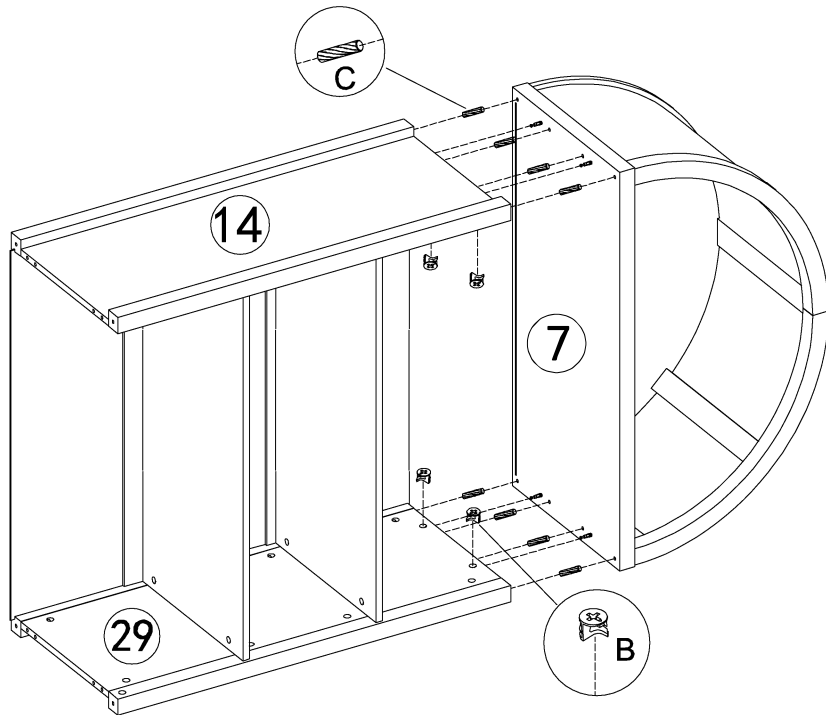



Step 18

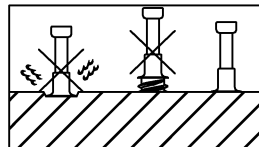
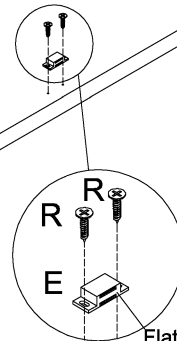
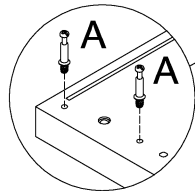
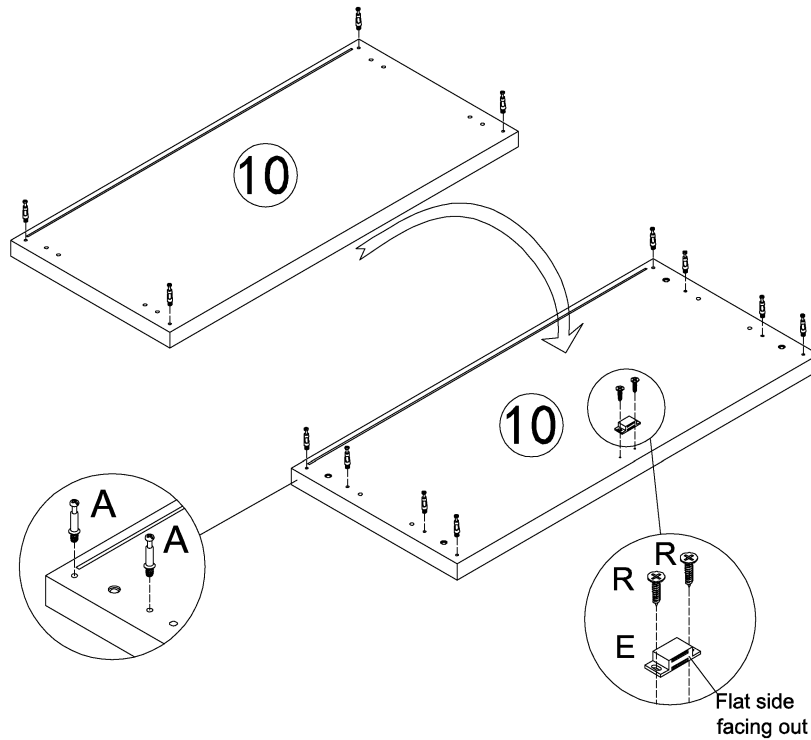

B*4	C*8
	





Step 19

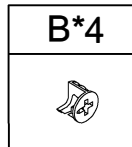
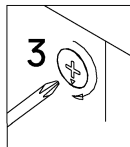
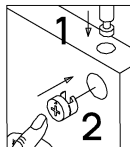
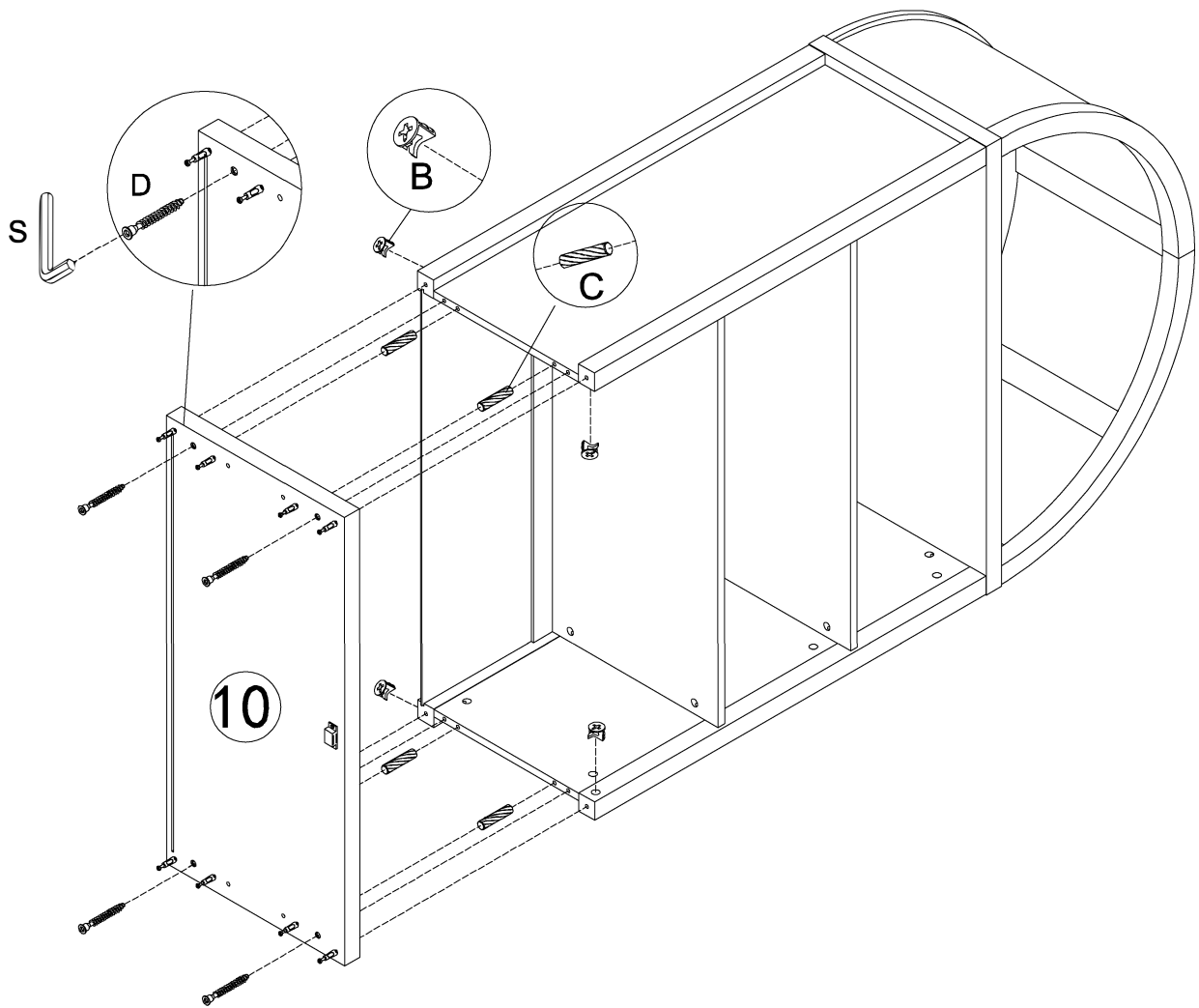

A*12	E*1	R*2
		

Step 20



B*4	S*1	C*4	D*4
			

Step 21

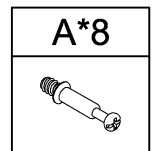
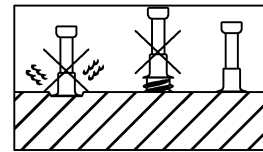
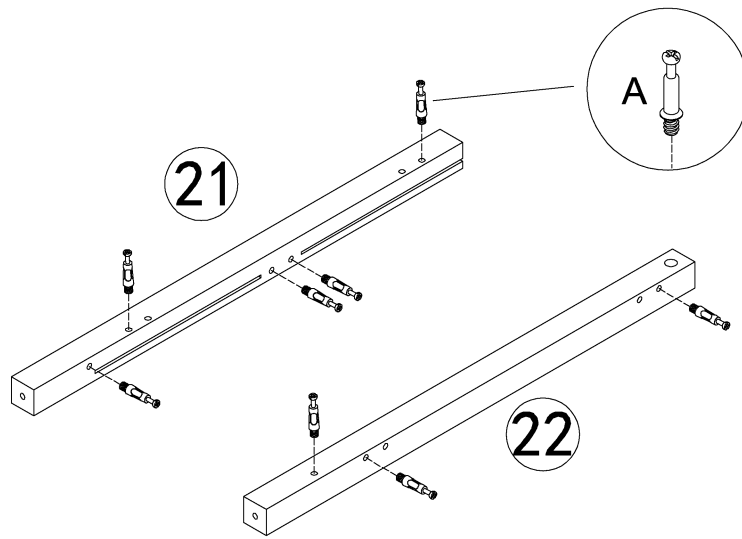

Step 22

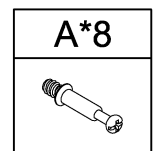
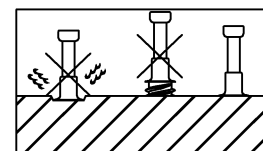
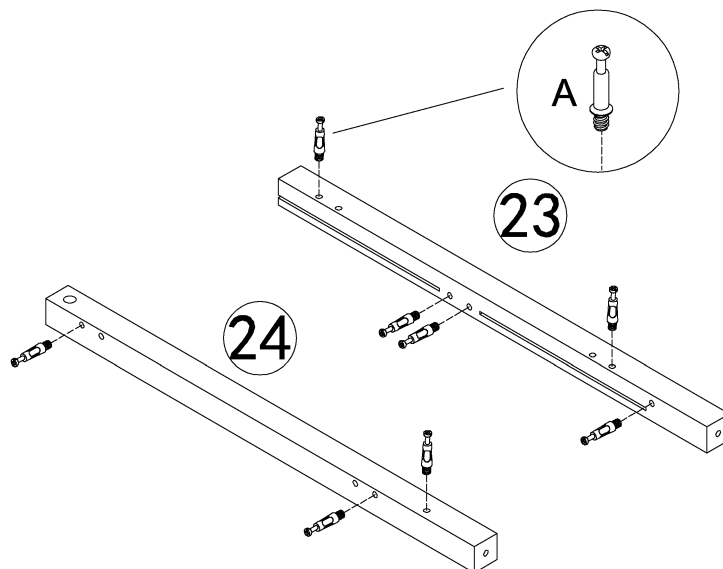

Step 23

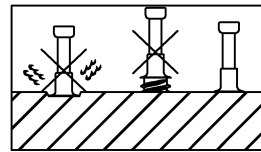
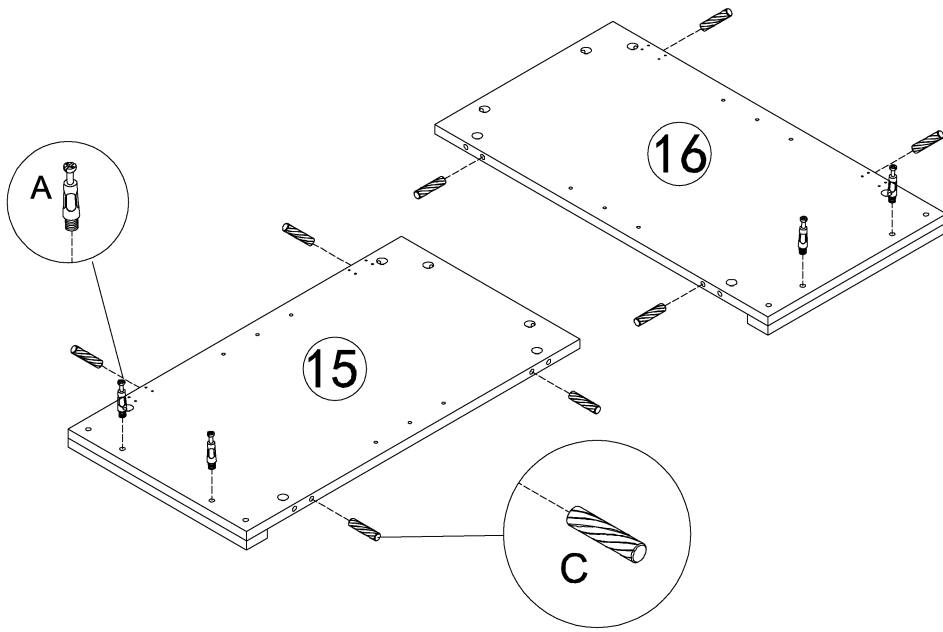

A*4	C*8

Step 24

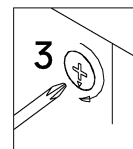
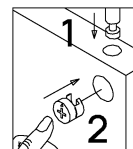
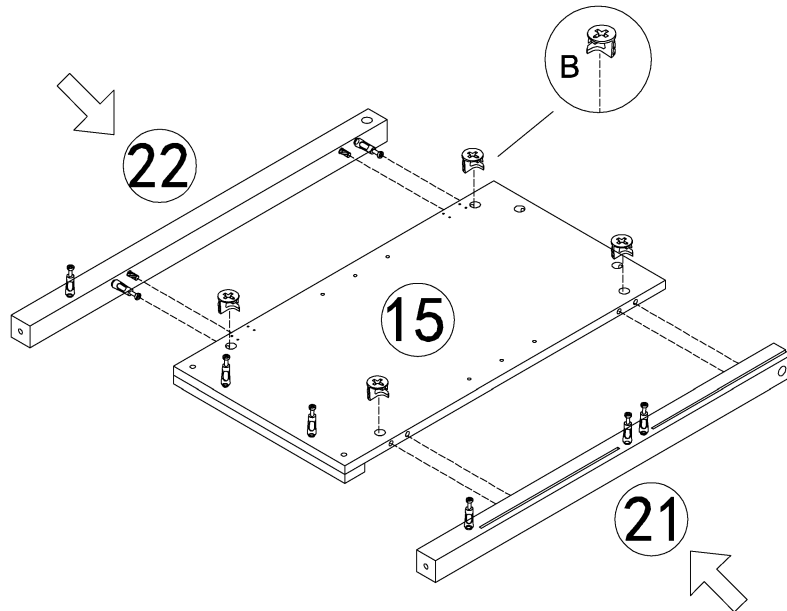

B*4

Step 25

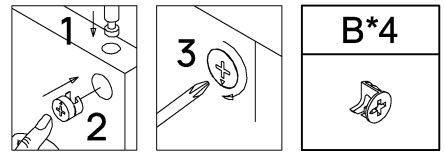
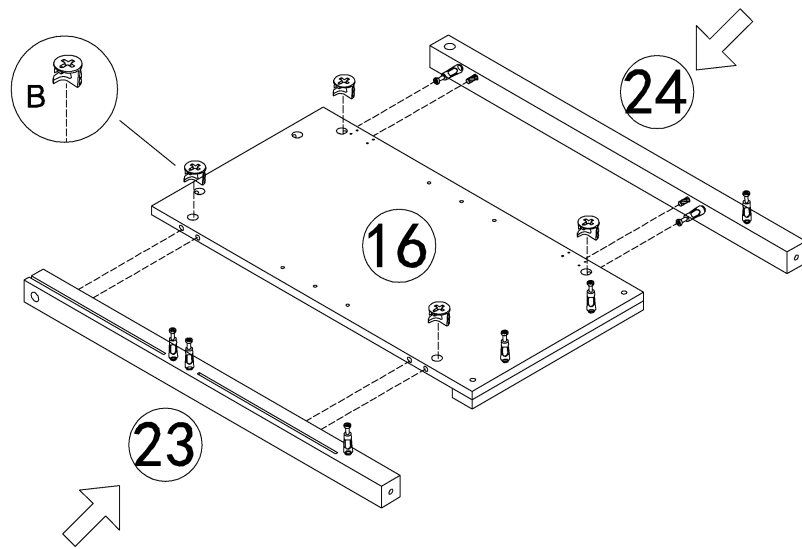

Step 26

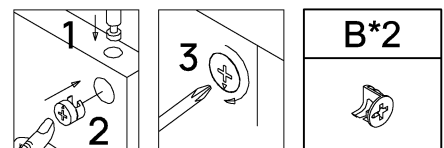
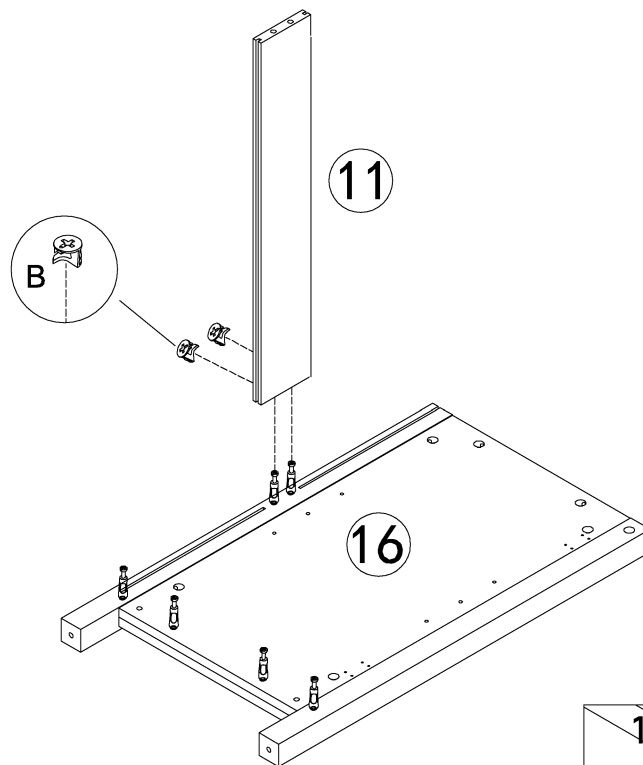

Step 27

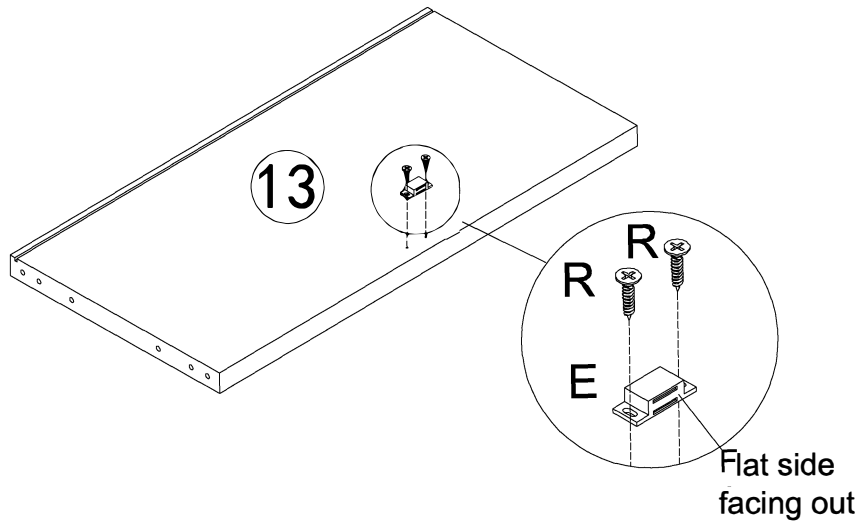

E*1	R*2

Step 28

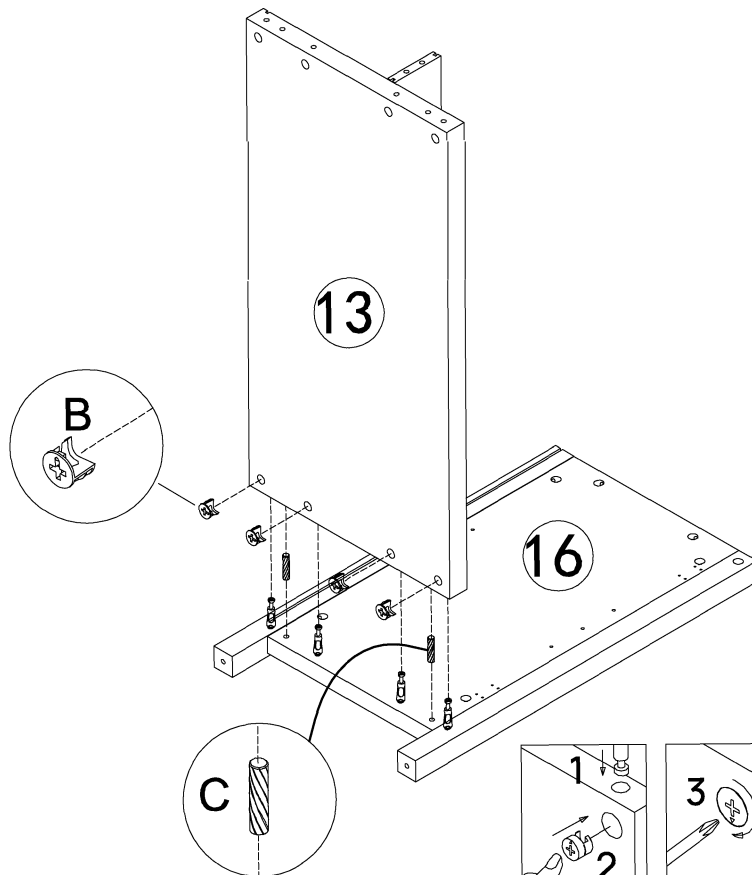

B*4	C*2

Step 29

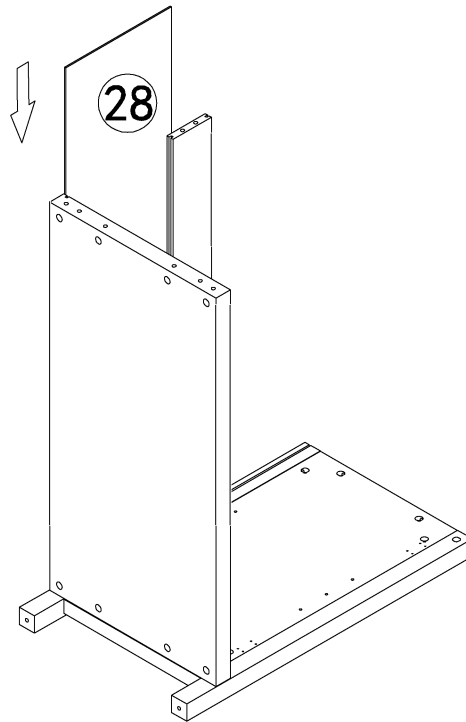

Step 30

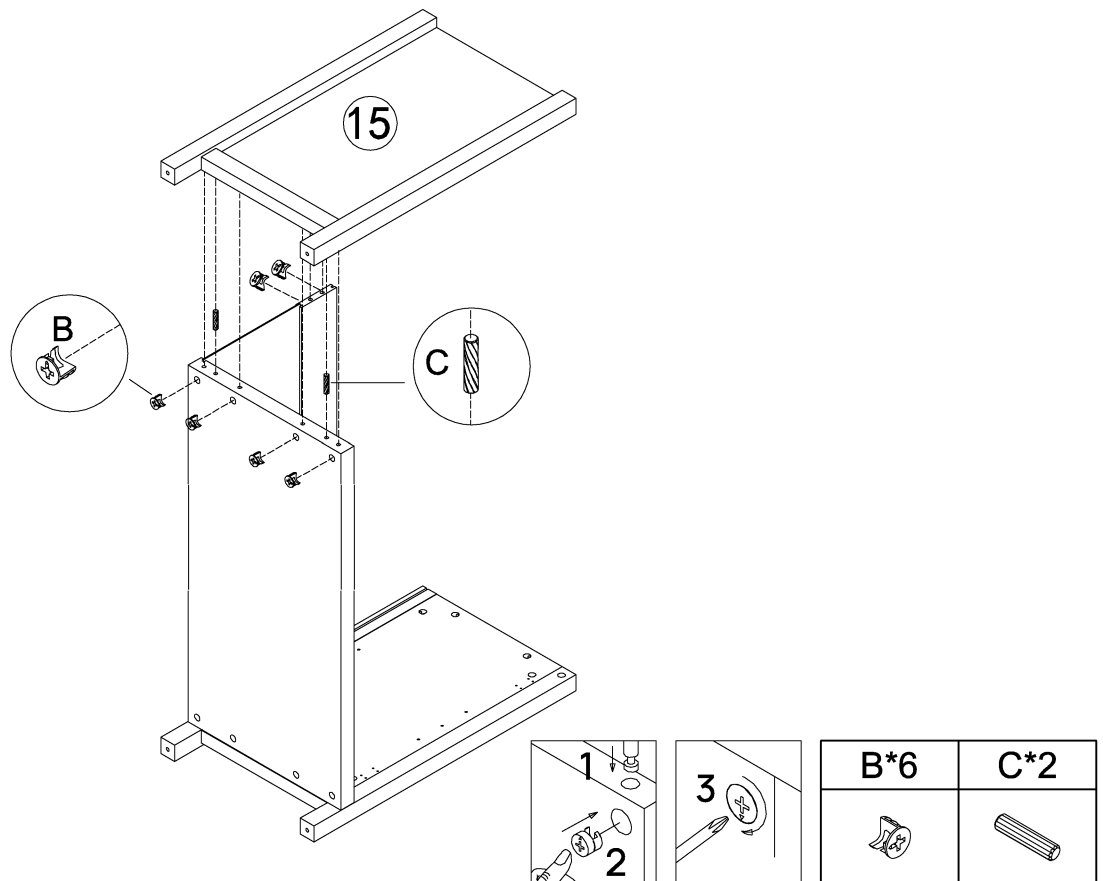

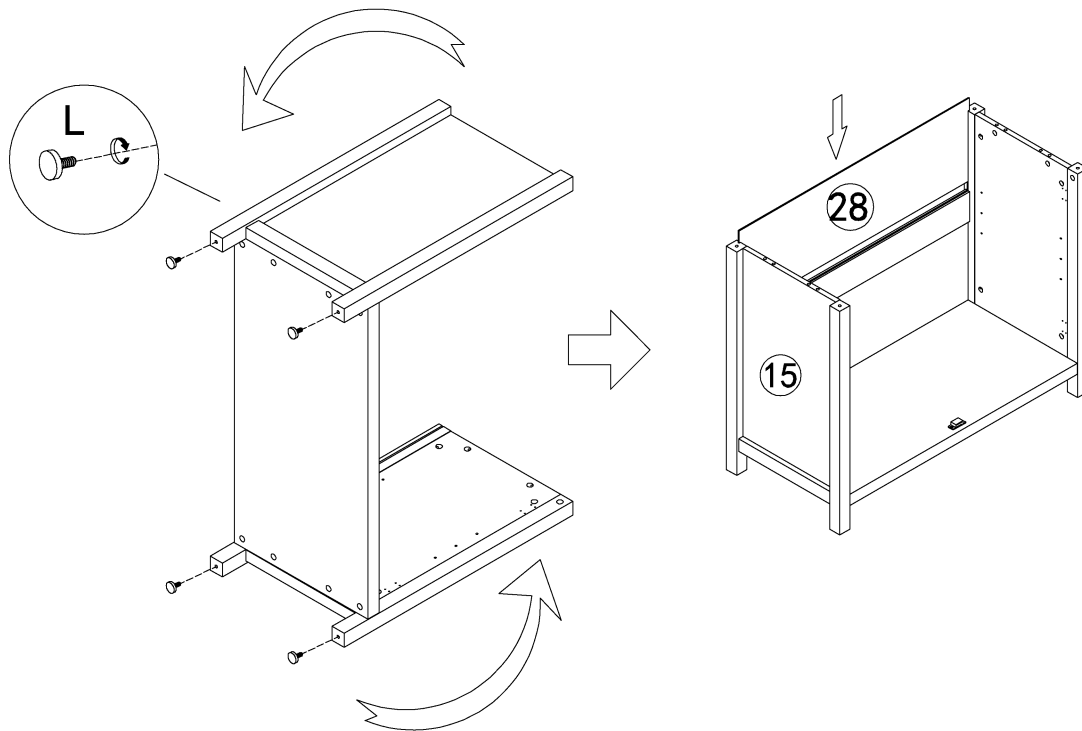

Step 31

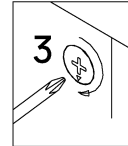
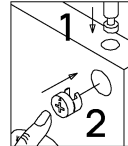
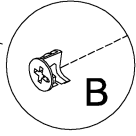
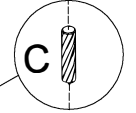
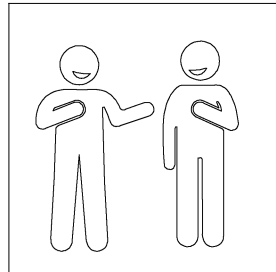
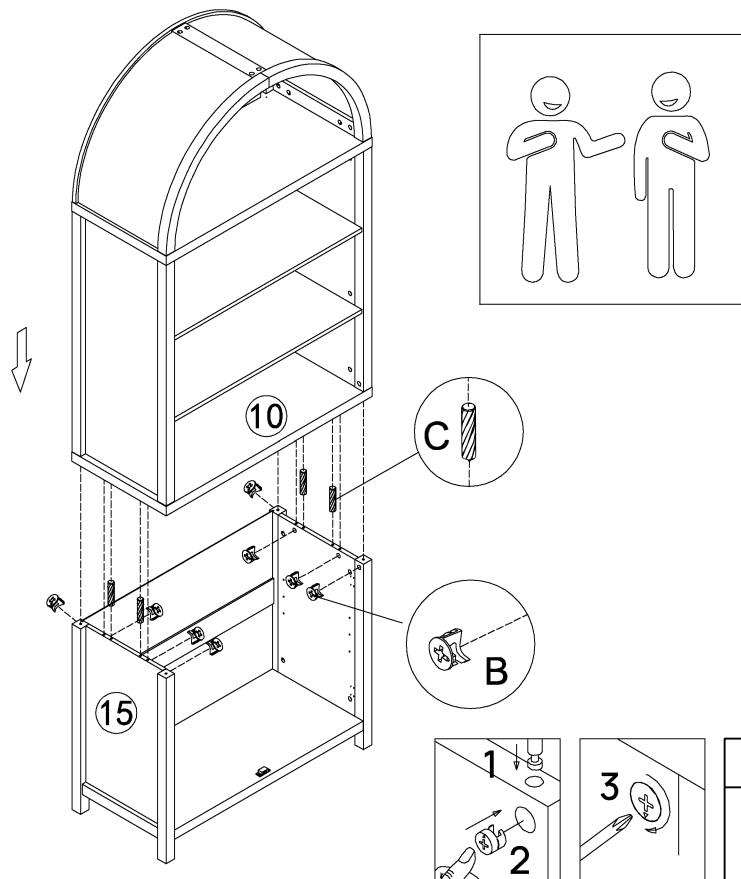

L*4

Step 32



B*8	C*4
	

Step 33

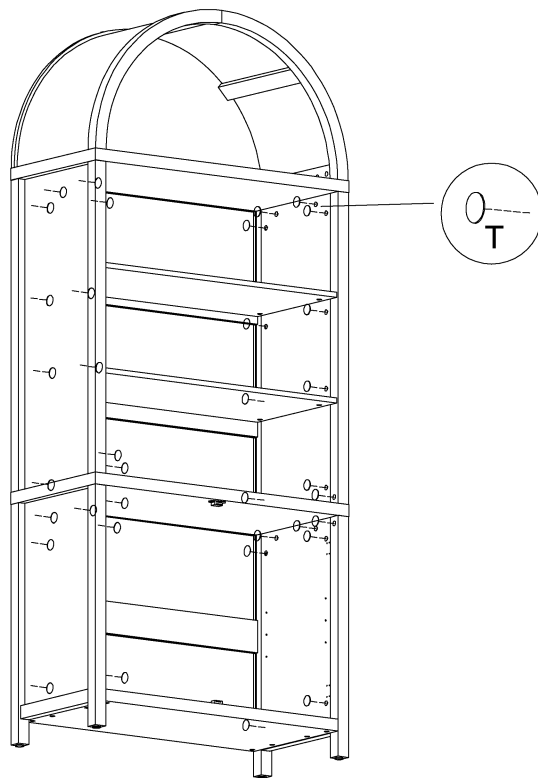

T*36

Step 34

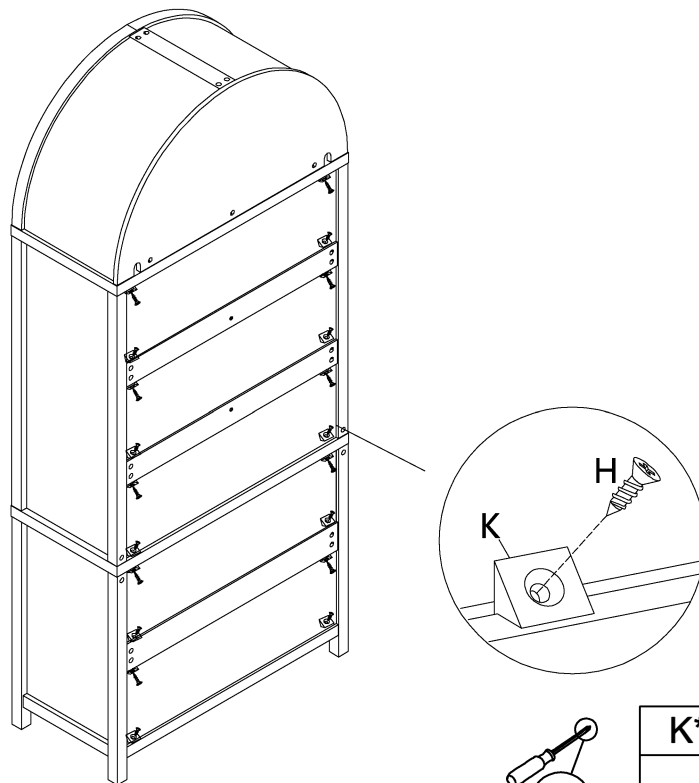

K*20	H*20

Step 35

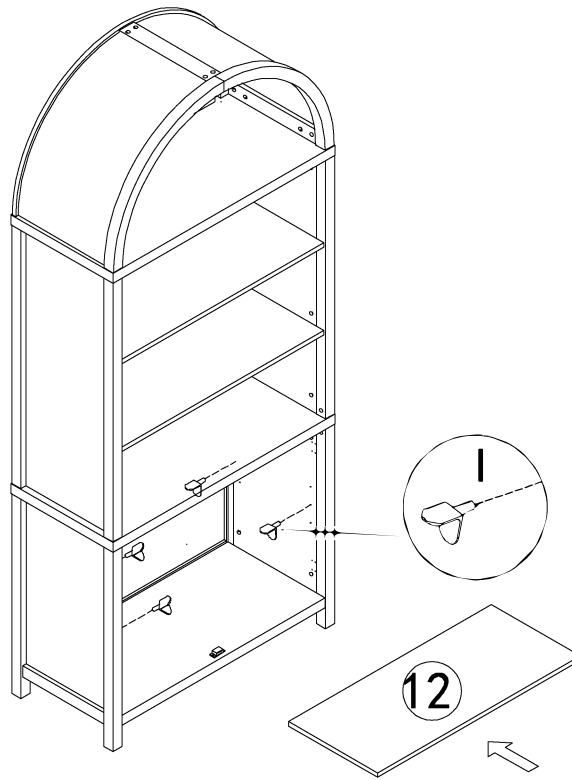

I*4

Step 36

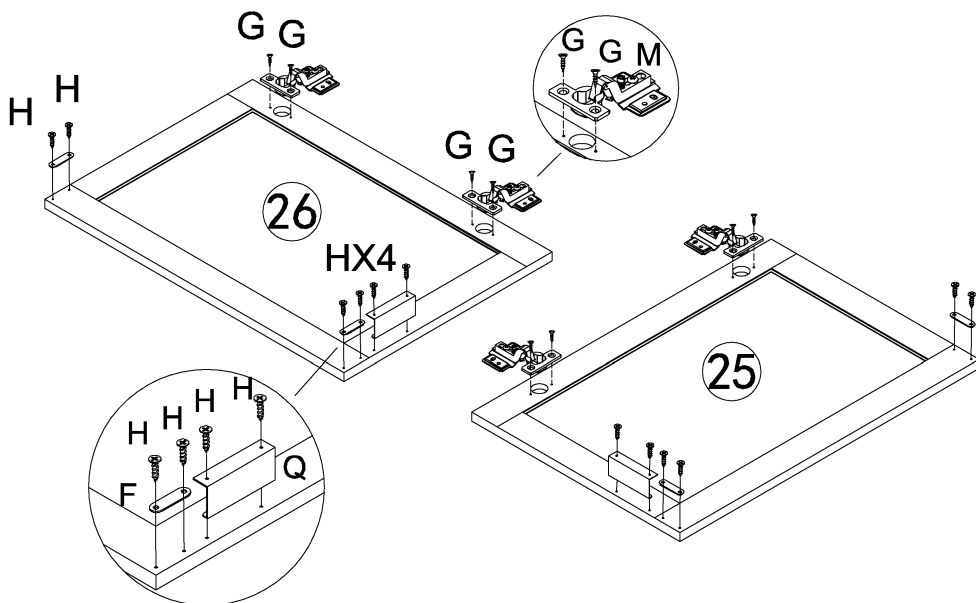

H*12	G*8	F*4	M*4	Q*2

Step 37

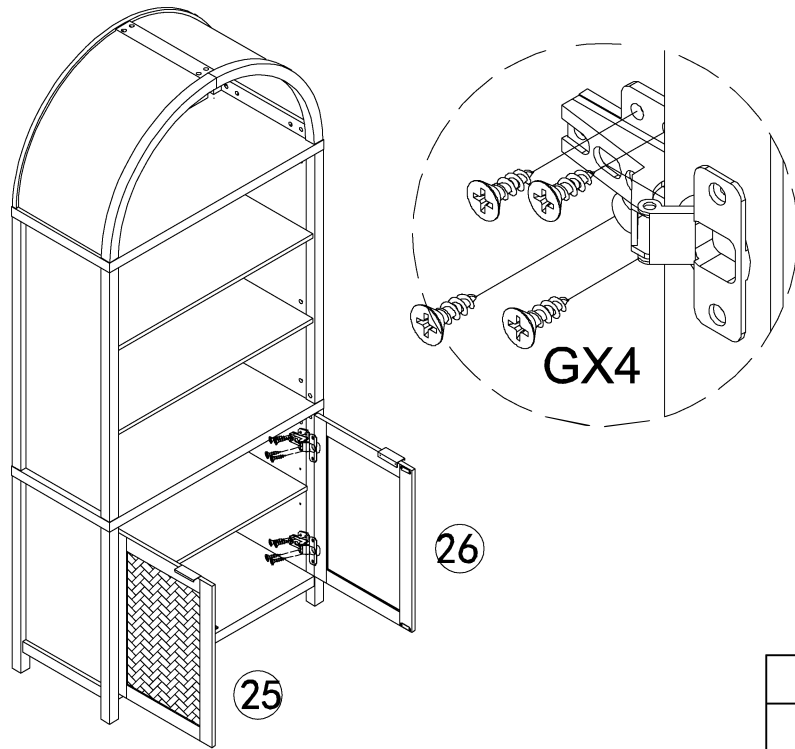

Step 38

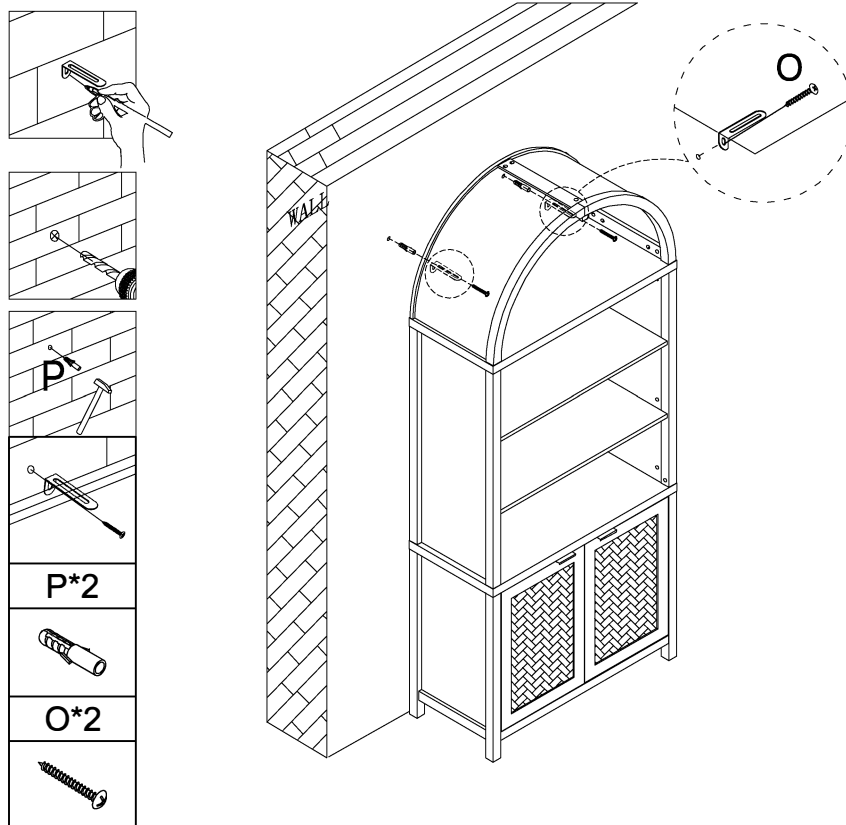

Cabinet Door Adjustment Instructions

Height adjustment:

- Locate the height adjustment screws on the hinge.
- Use the Phillips screwdriver to either tighten or loosen the screws to raise or lower the cabinet door as desired.

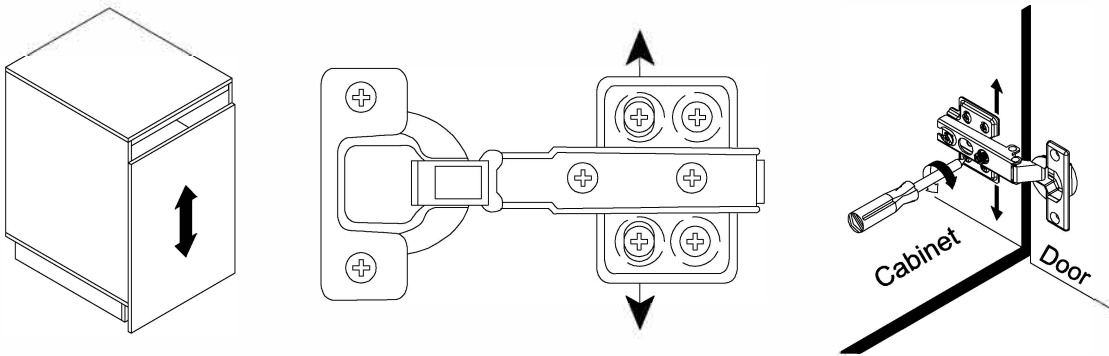

Side-to-side adjustment:

- If the cabinet door needs to be moved closer to or away from the cabinet frame, locate the side-to-side adjustment screws on the hinge.
- Use the Phillips screwdriver to adjust these screws and gradually move the door in the desired direction.

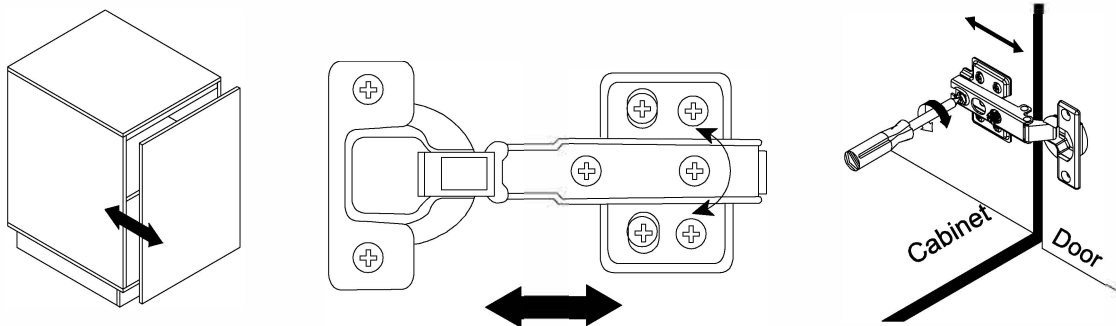

Depth adjustment (if applicable):

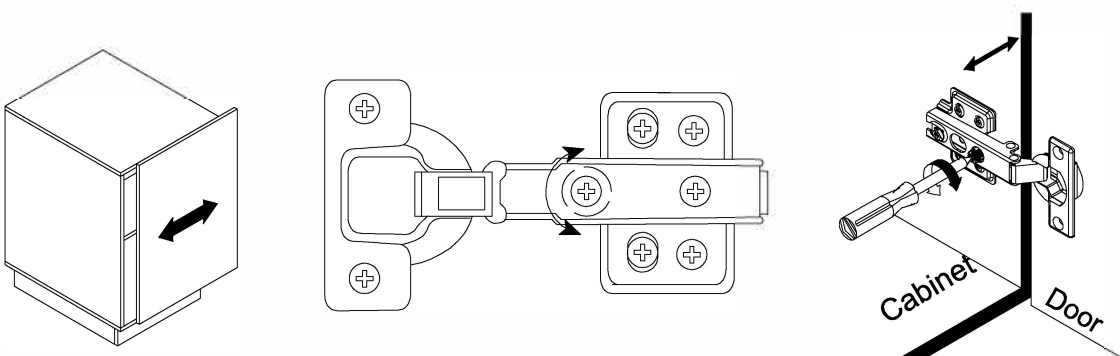

Step 39

