

Rattan Storage Bench

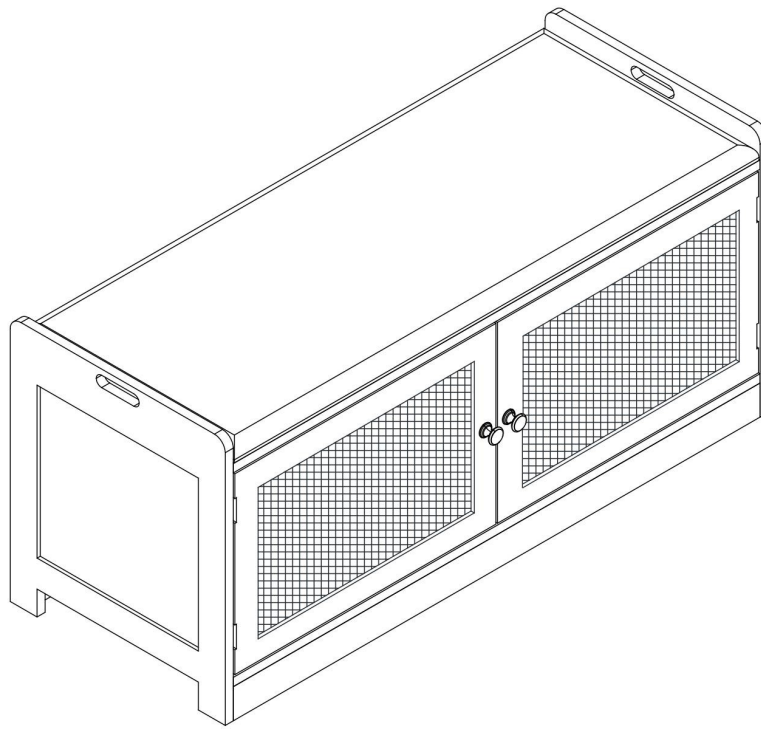

1 HOUR
ASSEMBLY TIME

2 PEOPLE
REQUIRED FOR ASSEMBLY

2 x 1 m
FLOOR SPACE REQUIRED

PLEASE READ ALL INSTRUCTIONS CAREFULLY BEFORE ASSEMBLING AND USING THE PRODUCT.

SAFETY ADVICE

- Keep the product away from fire and inflammable objects.
- Do not stand on the product or use the product as a stepladder.
- Do not overload, otherwise it will cause risk of injury and/or damage to the product.
- Never allow kids to climb on or lean against the product. The product comes with an anti-tip wall anchor. Do fix the anti-tip device to avoid potential injury.
- Check that the product is stably built before use and make sure the product stands on a solid and level surface.

CARE ADVICE

- Wipe with soft dry cloth.
- Never allow any sharp objects to touch the surface. It will damage the finish of the product.
- Never allow any kind of liquid to remain on the surface. Water penetration will cause damage to the wood material.
- Please periodically check all fittings and re-tighten as necessary.

ASSEMBLY ADVICE

- Ensure that you have sufficient space and people to assemble the product safely.
- Please check that all parts are present before you start the assembly. A Philips head screwdriver (not included) is required for the assembly.
- Please assemble the product on a protected surface (packaging box, or mat, etc) to avoid any damage.
- During assembly, do not tighten bolts/screws completely until all bolts/screws are lined up and inserted into holes; do not over-tighten screws and bolts to avoid stripping; do not use power tools.
- Please check that the product is well and stably built before usage.

KEEP ALL SAFETY ADVICE AND SAVE THIS INSTRUCTIONS FOR FUTURE REFERENCE

Guarantee

We offer 12-month warranty for all our products from the date of original purchase.

Statement:

The product is well-packed with strengthened box and protective foam. Each panel is separately wrapped with soft protective foam, while the hardware is included in a single box. An instructions manual should be included in the box as well. Well protected though, damage happens sometimes.

To successfully assemble the item and enjoy your cozy furniture, please kindly check the parts and accessories according to the packing list in the next two pages.

If there are any parts missing, damaged or defective, please feel free to contact us for support via the following email. You can contact us for support at any time. Usually we will respond to you within 24 hours.

The information required for a better support from us:

Order Number:

Part Number needed to replace:

Shipping Information (Name, Address, Contact Number):

Picture of the damaged/defective parts (if possible):

Note: If the instructions manual is missing pages, there is a QR Code printed on the packaging box where you can scan and download the electrical instructions for reference. If error happens, contact us via email directly.



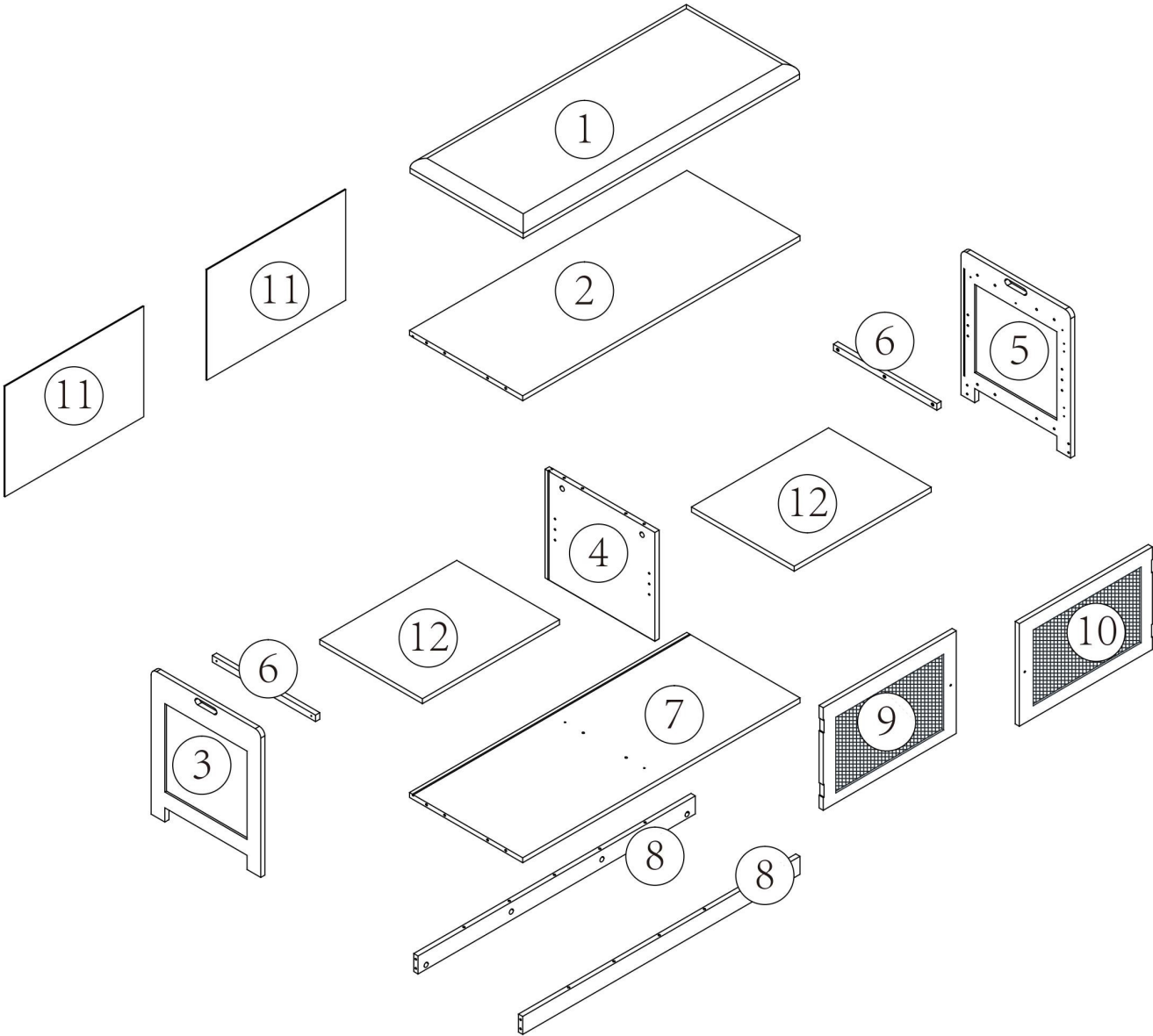







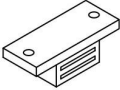
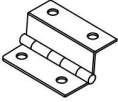

Product Diagram

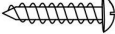

After-sales Support

If there are any parts missing, damaged or defective, please feel free to contact us for support via the following email. Information required is listed on Page 3.

Hardware List

A		B		C	 3x12mm	D	
18 PCS		18 PCS		20 PCS		2 PCS	
E		F	 6x30mm	G		H	 4x20mm
4PCS		22 PCS		2 PCS		2PCS	
I	 4x25mm	J	 6x35mm	K		L	
6 PCS		2 PCS		2PCS		8 PCS	
M	 3x16mm	N					
12PCS		8PCS					

Step 1

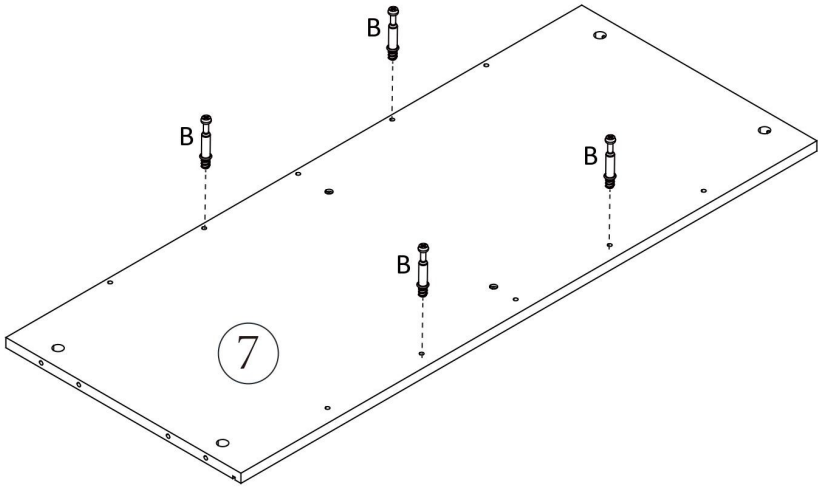
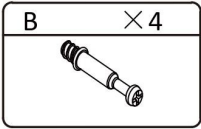

Step 2

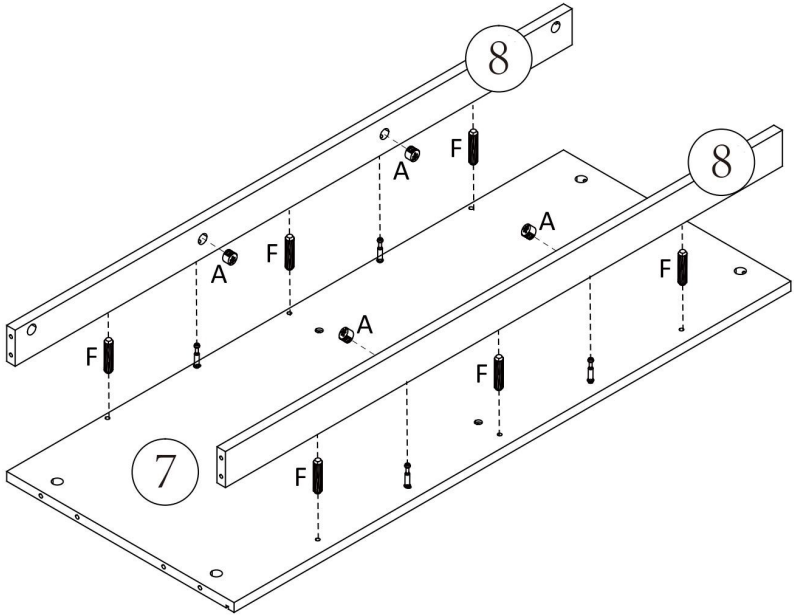
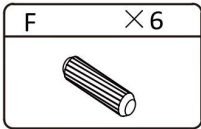
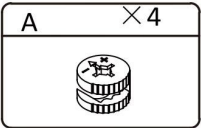

Step 3

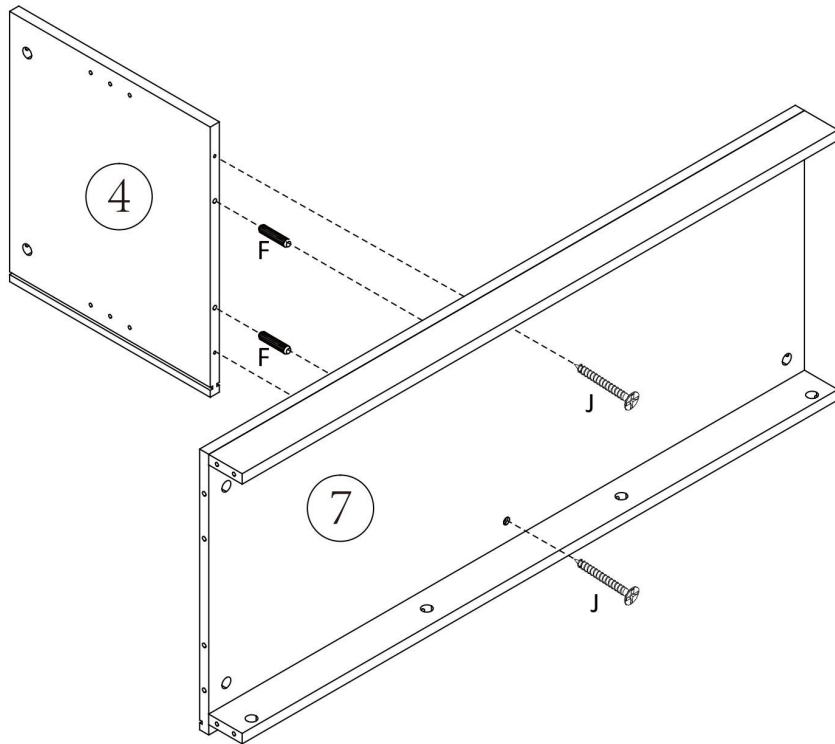
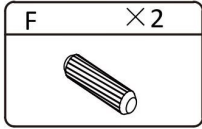
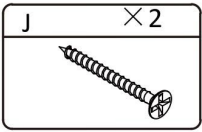

Step 4

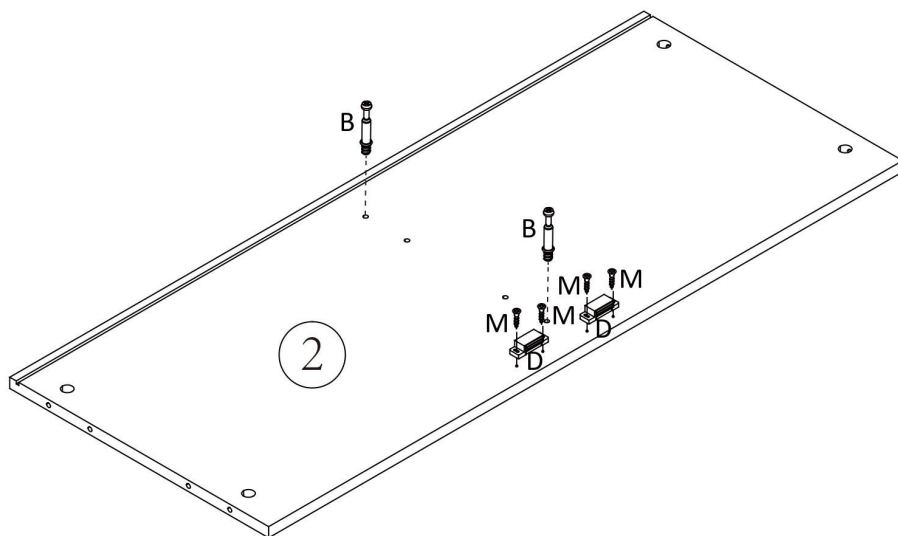
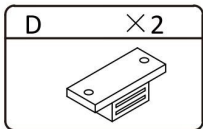
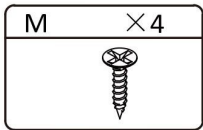
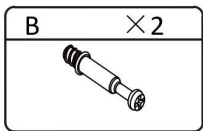

Step 5

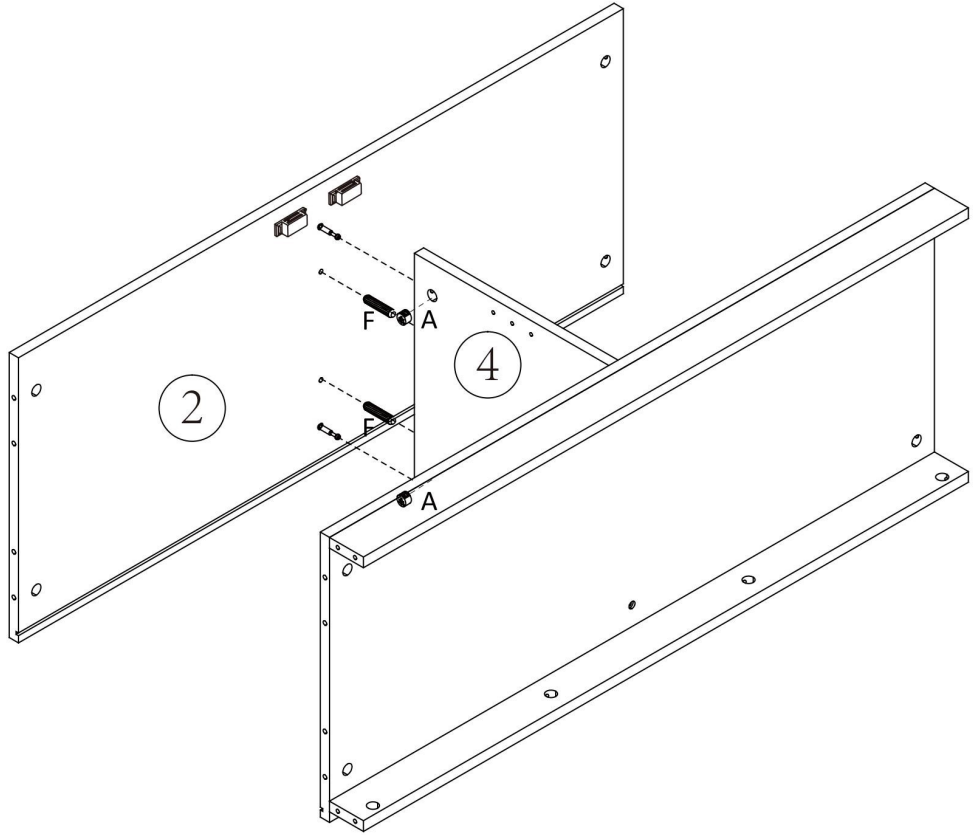
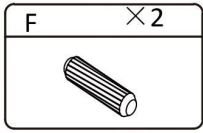
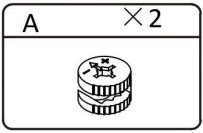

Step 6

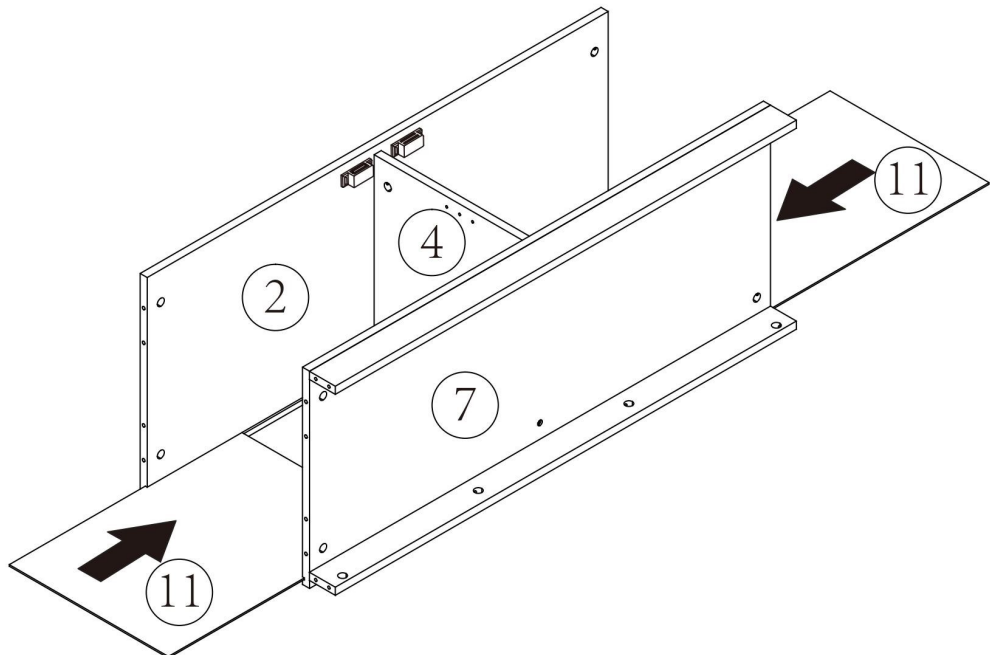

Step 7

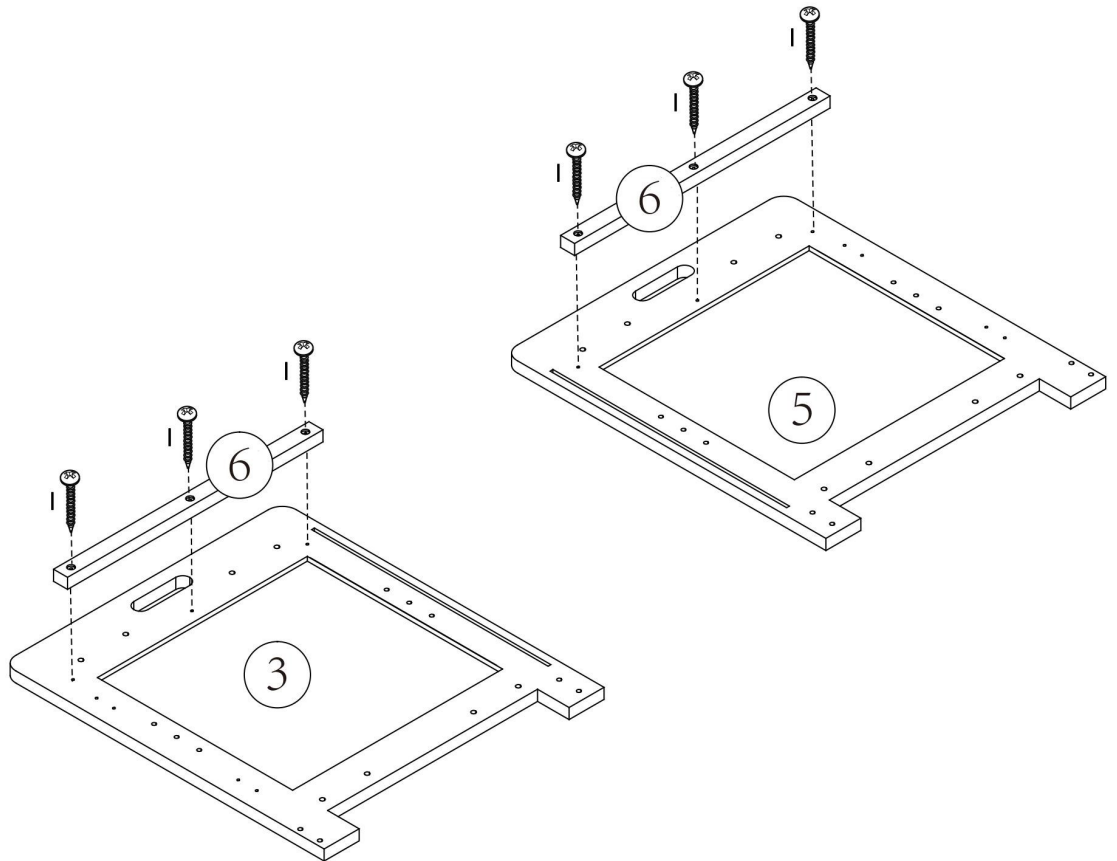
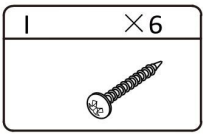

Step 8

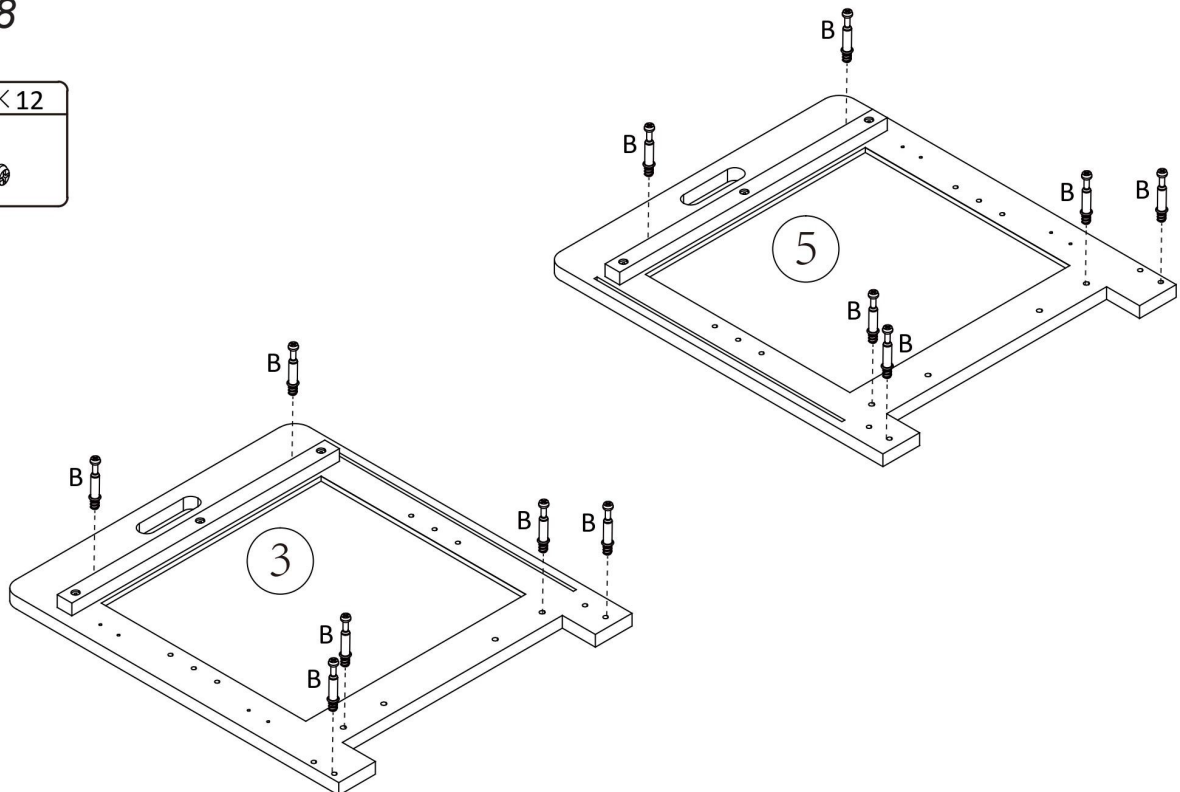
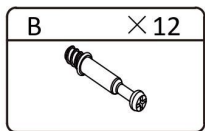

Step 9

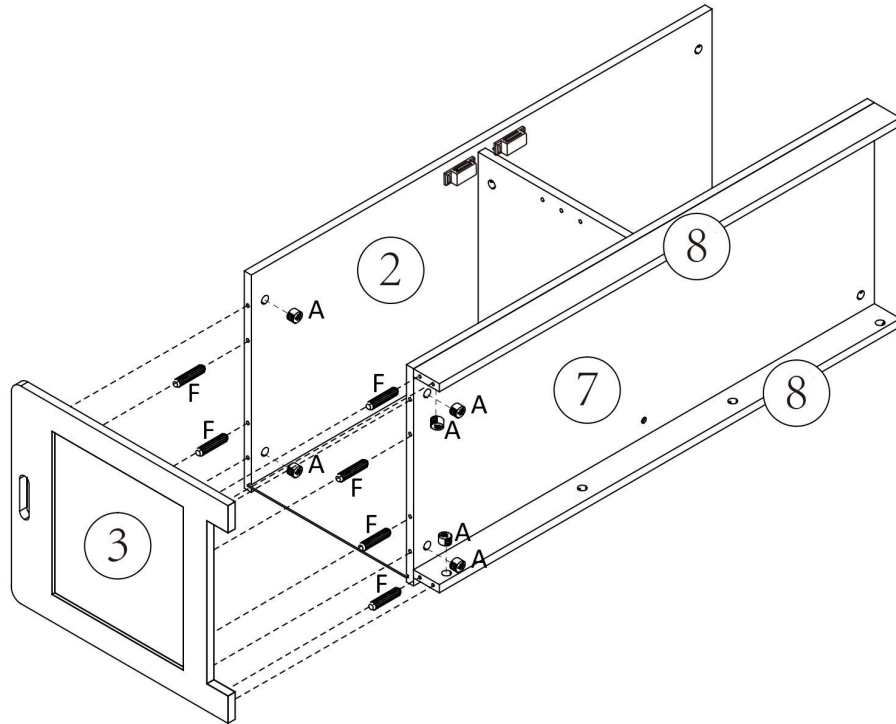
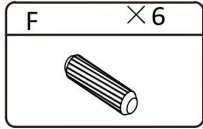
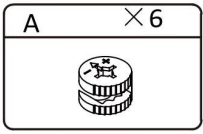

Step 10

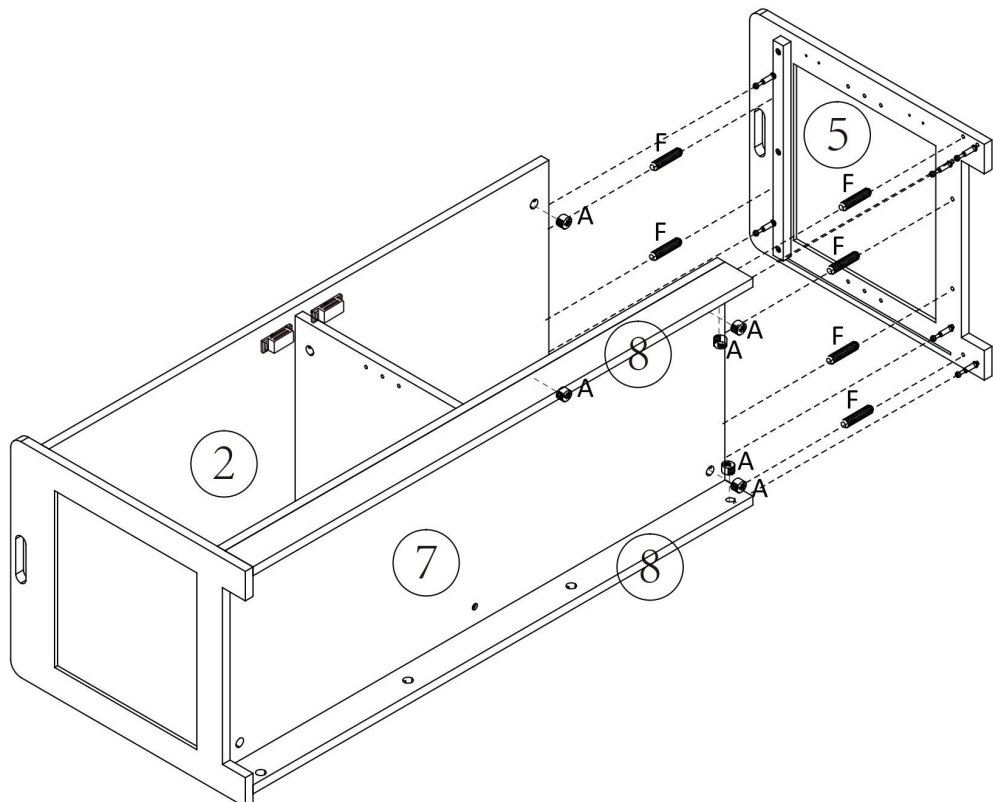
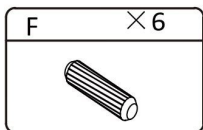
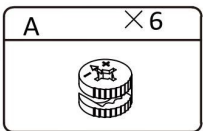

Step 11

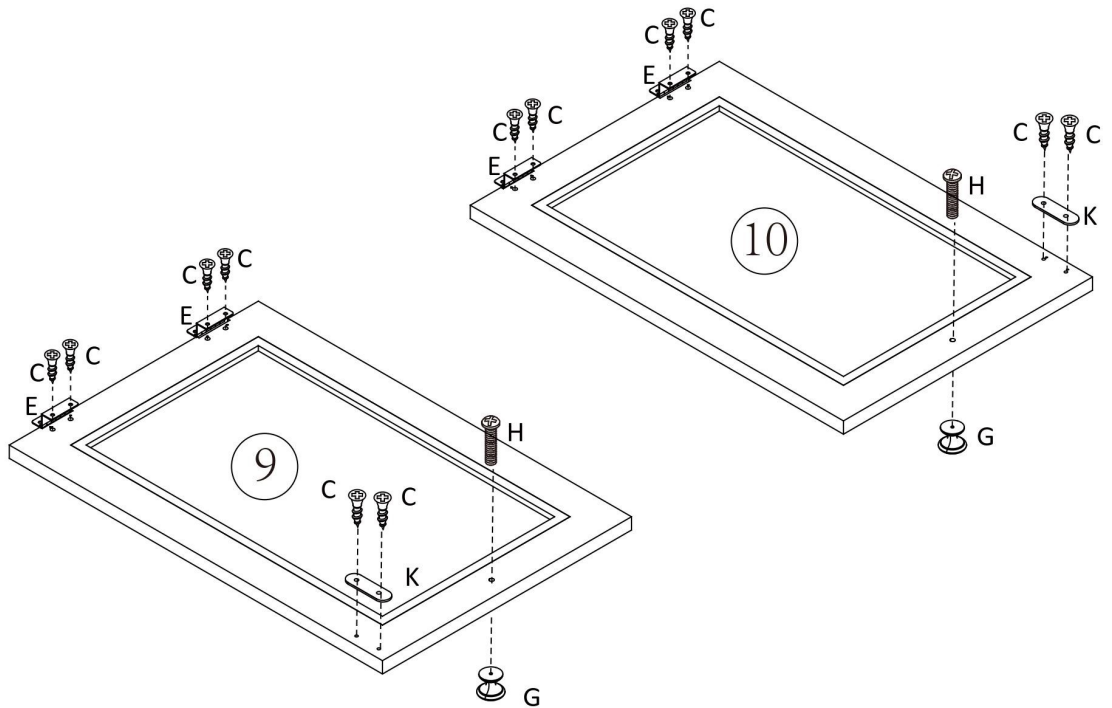
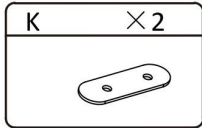
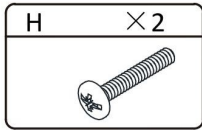
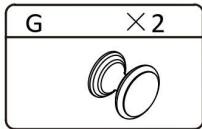
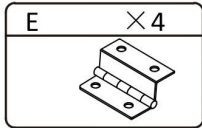
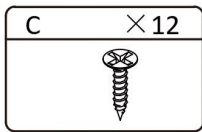

Step 12

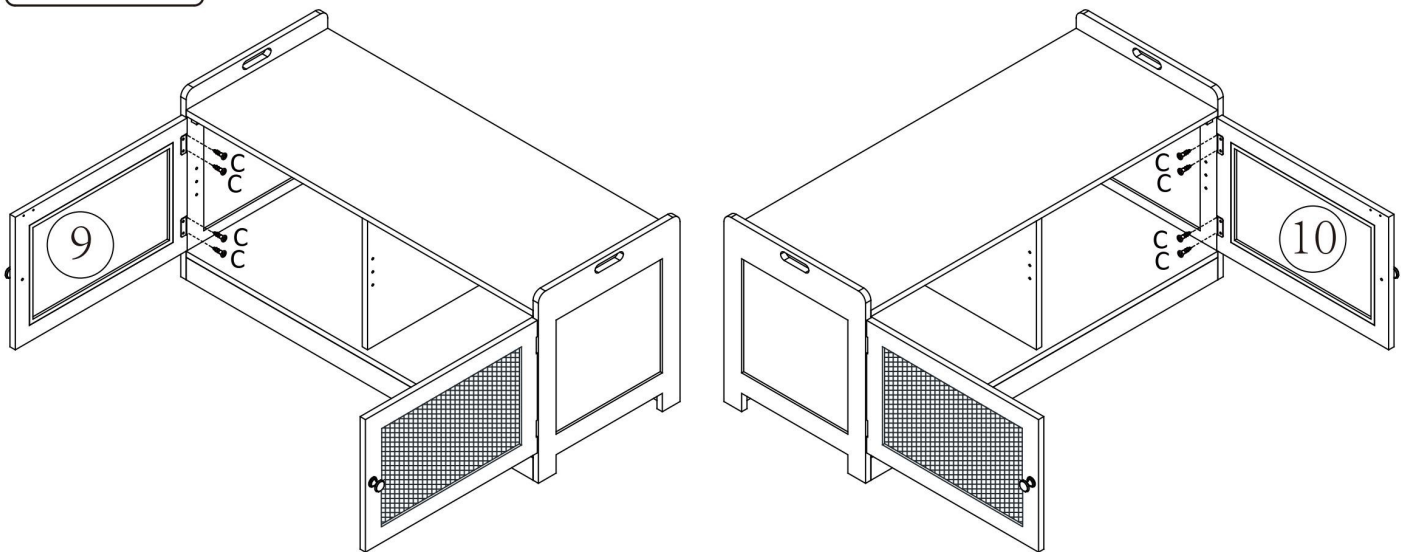
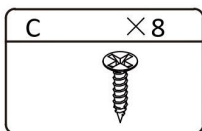

Step 13

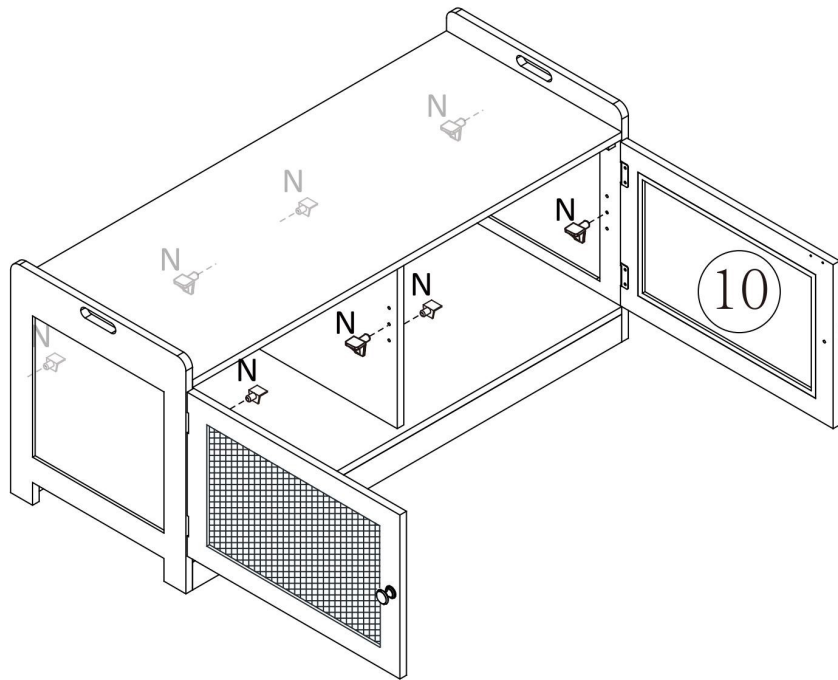
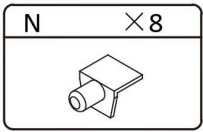

Step 14

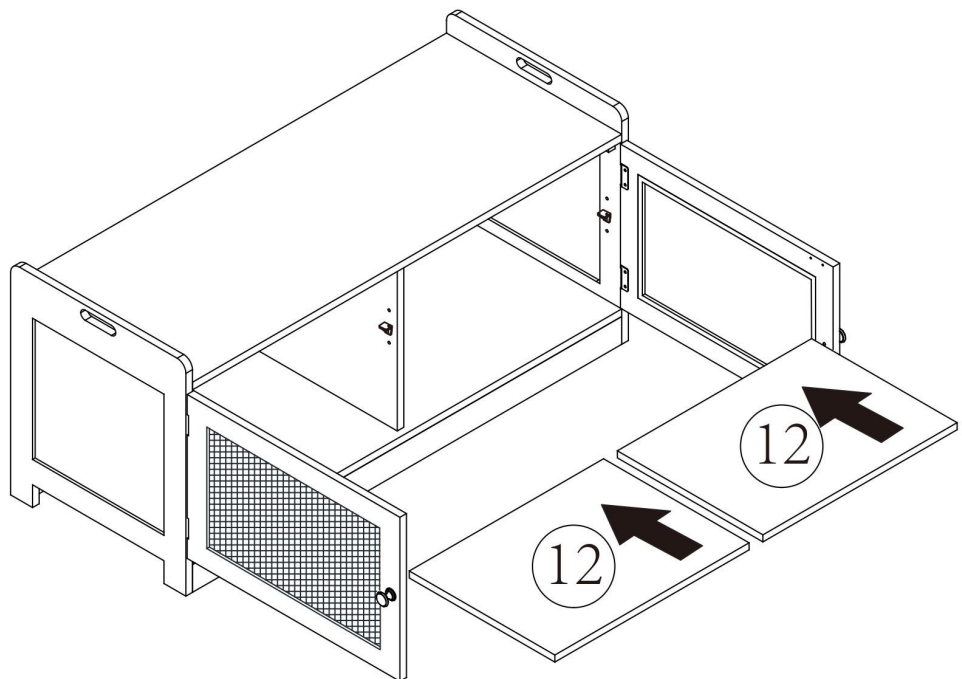

Step 15

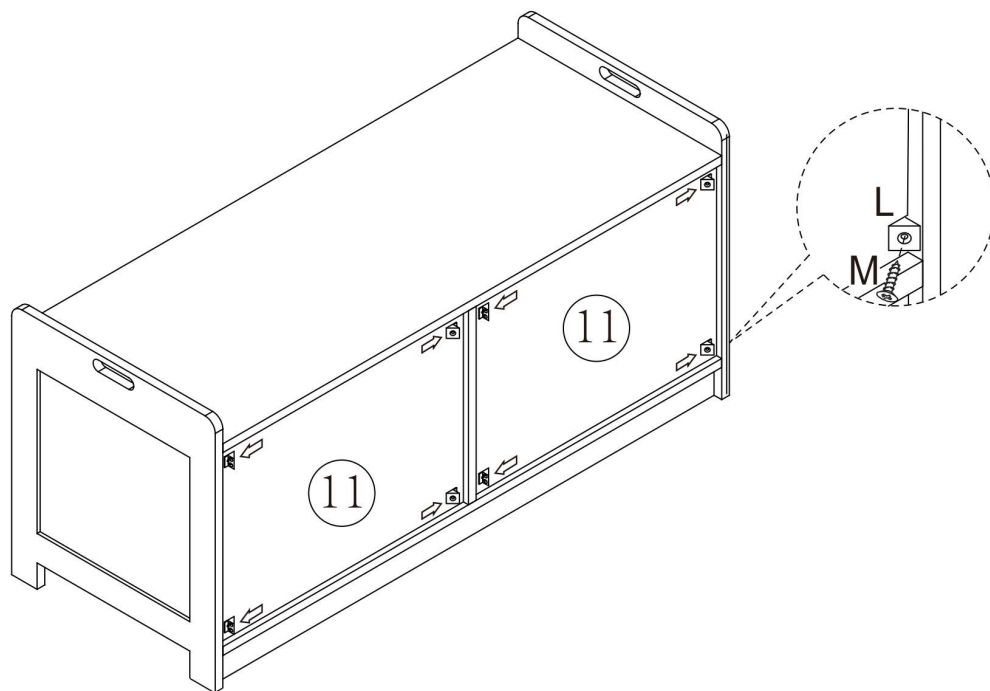
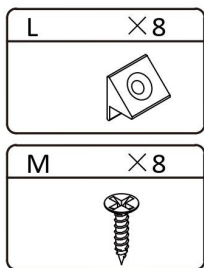

Kindly note:

This is a very important step that can not be skipped. Please follow the step to screw the plastic pieces into the corner of the back panel tightly. If you forget to fix these pieces, it may result in the instability of the whole item.

Step 16

