

Suggestion:

For a simpler and quicker assembly process,
we recommend that two people work together.

Due to the product's structure, the estimated assembly time is 90 minutes.

IMPORTANT:

1. Please read the instructions carefully before assembling the product.
2. Before starting the assembly process, check the package carefully to make sure all necessary boards and parts are included.
3. If there are any defective or missing parts after unpacking, please stop assembly and immediately contact us.
4. Before assembly, put all parts and boards in an open area. Ensure that you have the correct parts before screwing them in place.

Warning:



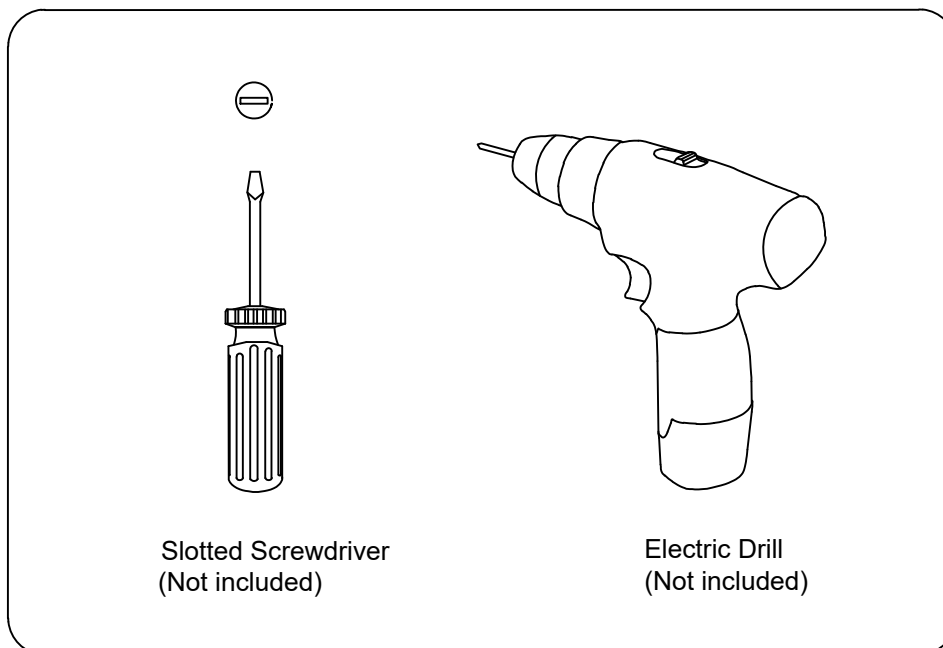

1. During assembly, keep all small objects out of the reach of children, as they may be fatalif swallowed or inhaled
2. Never allow children to climb or play around the product to protect children from injury caused by the tilting of the product.
3. To avoid the potential dangers of suffocation, please keep all parts and packaging away from children.

Self equipped tools



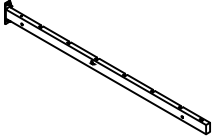
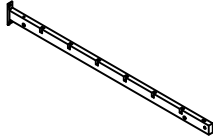
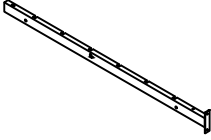
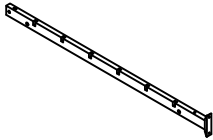
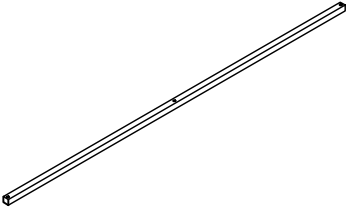
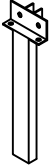
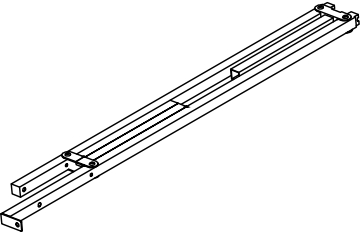

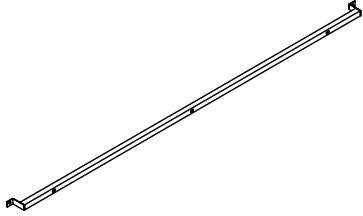

Parts Identification 1/4

Not actual size

<p>①</p>  <p>Q'ty: 1</p>	<p>②</p>  <p>Q'ty: 1</p>	<p>③</p>  <p>Q'ty: 1</p>
<p>④</p>  <p>Q'ty: 1</p>	<p>⑤</p>  <p>Q'ty: 1</p>	<p>⑥</p>  <p>Q'ty: 2</p>
<p>⑦</p>  <p>Q'ty: 1</p>	<p>⑧</p>  <p>Q'ty: 1</p>	<p>⑨</p>  <p>Q'ty: 1</p>
<p>⑩</p>  <p>Q'ty: 1</p>	<p>⑪</p>  <p>Q'ty: 1</p>	<p>⑫</p>  <p>Q'ty: 1</p>

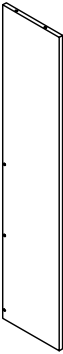
Parts Identification 2/4

Not actual size

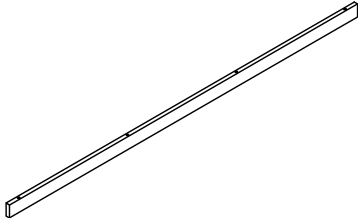
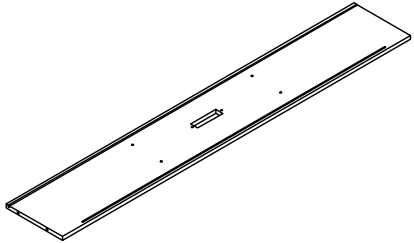
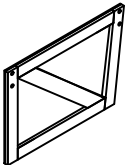
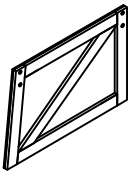
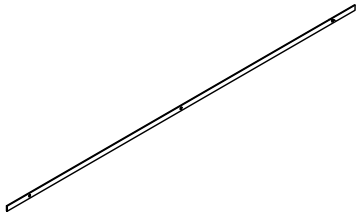
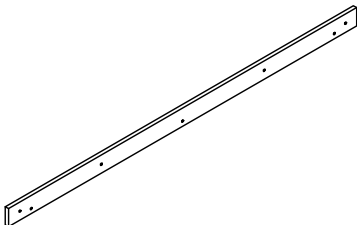
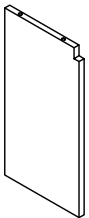
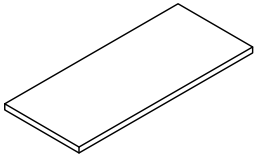
<p>13</p>  <p>Q'ty: 1</p>	<p>14</p>  <p>Q'ty: 1</p>	<p>15</p>  <p>Q'ty: 1</p>
<p>16</p>  <p>Q'ty: 1</p>	<p>17</p>  <p>Q'ty: 1</p>	<p>18</p>  <p>Q'ty: 1</p>
<p>19</p>  <p>Q'ty: 1</p>	<p>20</p>  <p>Q'ty: 1</p>	<p>21</p>  <p>Q'ty: 1</p>
<p>22</p>  <p>Q'ty: 1</p>	<p>23</p>  <p>Q'ty: 1</p>	<p>24</p>  <p>Q'ty: 1</p>

Parts Identification 3/4

Not actual size

25

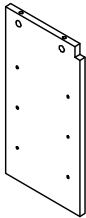

Q'ty: 1

26

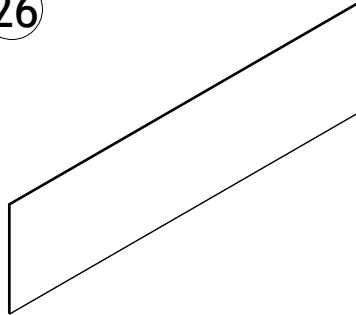

Q'ty: 1

27

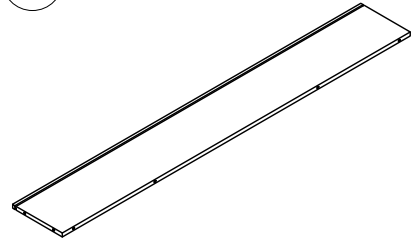

Q'ty: 1

28

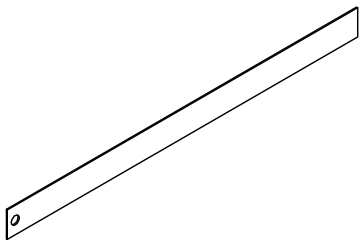

Q'ty: 1

29

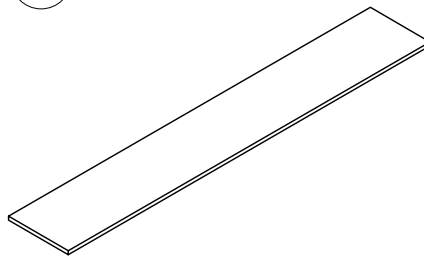

Q'ty: 1

30

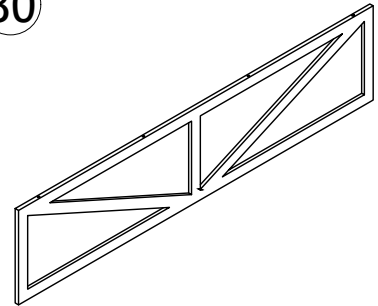

Q'ty: 1

31

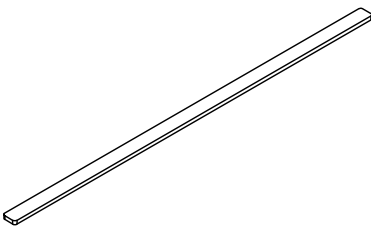

Q'ty: 1

32

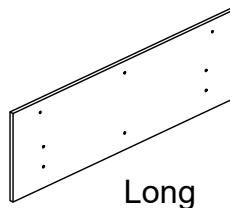

Long

Q'ty: 2

33

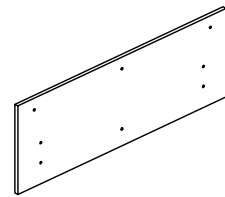

Q'ty: 2

34

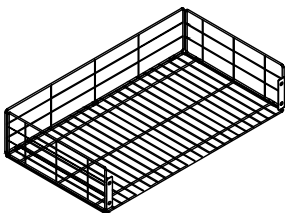

Q'ty: 2

35

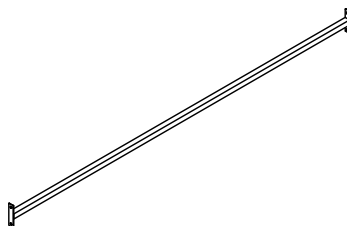

Q'ty: 1

36

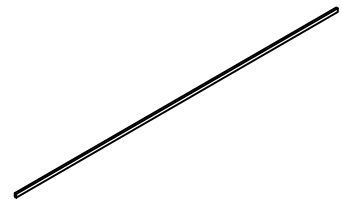

Q'ty: 12

Parts Identification 4/4

Not actual size

37

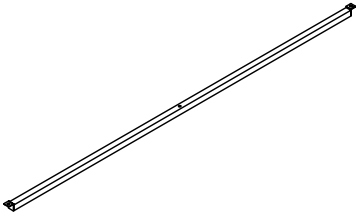

Q'ty: 2

38

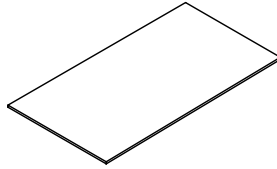

Q'ty: 2

Hardware List

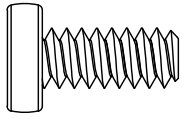

M8 x 28mm

(A)

x 2+1

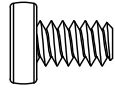

Ø1/4" x 11mm

(B)

x 39+3

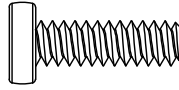

Ø1/4" x 28mm

(C)

x 7+1

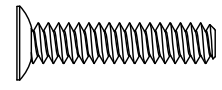

Ø1/4" x 28mm

(D)

x 3+1

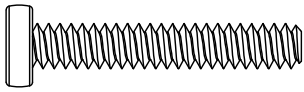

Ø1/4" x 50mm

(E)

x 3+1



Ø5 x 38mm

(F)

x 16+1

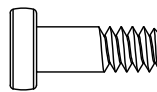

Ø1/4" x 16mm

(G)

x 2+1

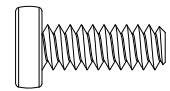

Ø1/4" x 16mm

(H)

x 12+1

BOLT
spare: 2

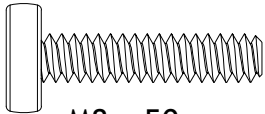

M8 x 50mm

(I)

x 4+1

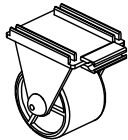

(J)

x 8



Ø4 x 12mm

(K)

x 6+1

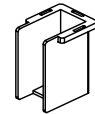

(L)

x 24+2

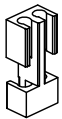

(M)

x 4

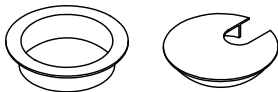

(N)

x 1



(O)

x 4



(P)

x 3

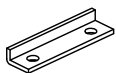

(Q)

x 2



(R)

x 4+1



(S)

x 2

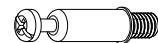

(T)

x 26+2

Hardware List



U

x 26+2

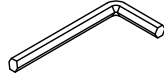

M3

V

x 1

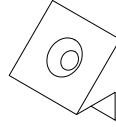

W

x 6



X

x 1

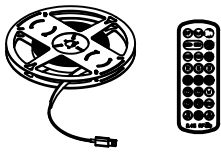

Y

x 1

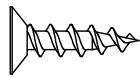

Ø3 x 15mm

Z

x 6

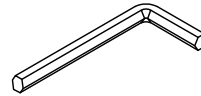

M4

AA

x 1

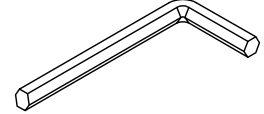

M5

BB

x 1



CC

x 1

★ In many cases, we include additional hardware. So after following the assembly instructions, don't worry if there are still extra pieces left over-they're included as a "just in case" for your convenience.

★ NOTE: When assembling, please do not tighten the screws one by one completely first, until making sure that all the corresponding screws are placed in the right positions.

Parts Identification

Not actual size

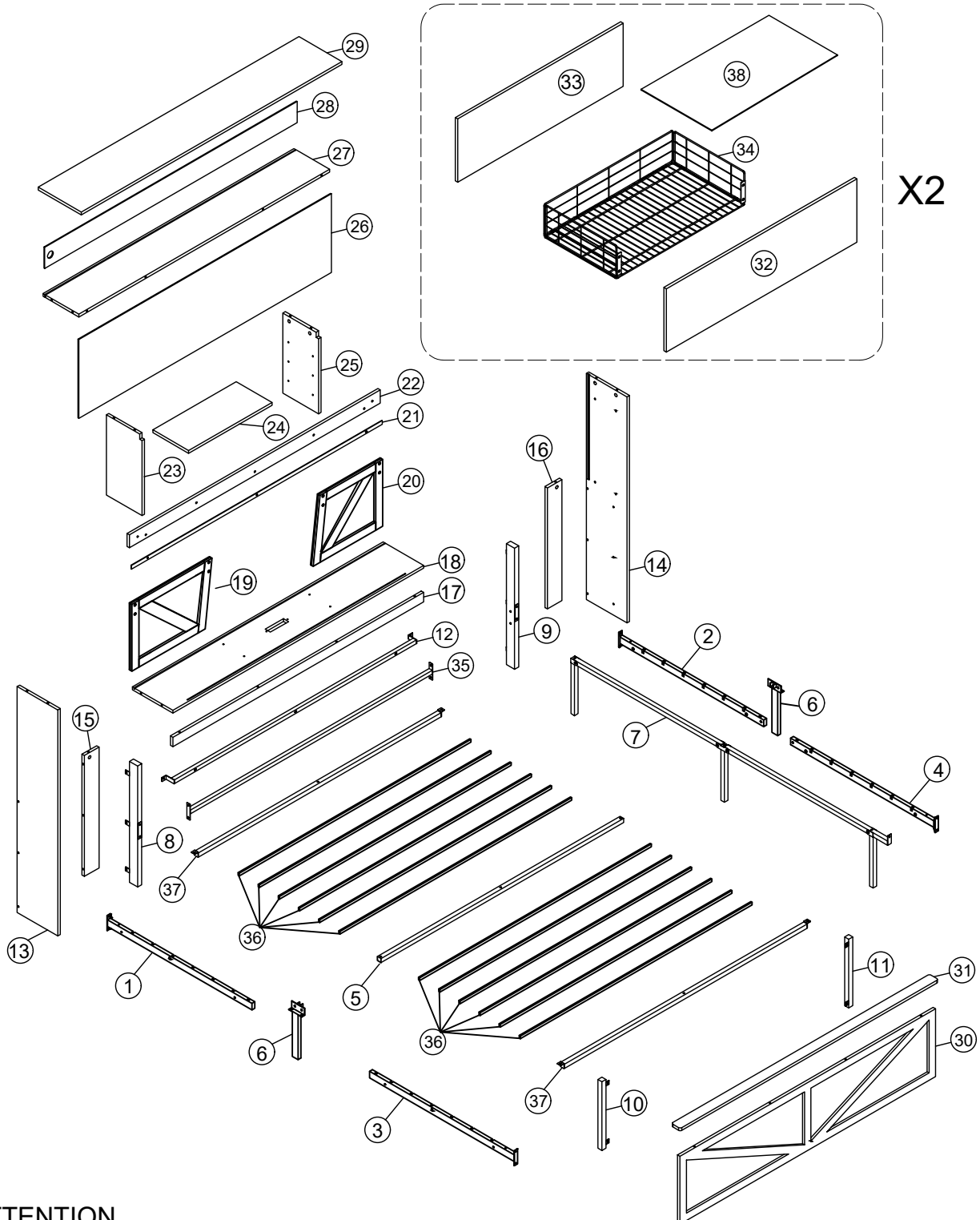







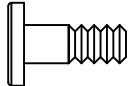

ATTENTION

When you begin each step, please check carefully whether you have taken the correct parts, so as not to use the wrong parts and cause the wrong assembly.

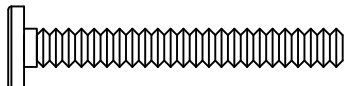
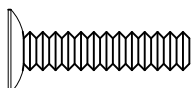
We recommend that you do not rush to tighten the screws. It is best to tighten the screws to two-thirds first, after all the steps are finished and the position is well adjusted, then tighten.

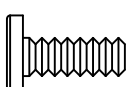
Screw Fitting 1:1 Diagram

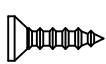
F		Ø5 x 38mm
B		Ø1/4" x 11mm
G		Ø1/4" x 16mm
C		Ø1/4" x 28mm
E		Ø1/4" x 50mm
D		Ø1/4" x 28mm
A		M8 x 28mm
I		M8 x 50mm
H		Ø1/4" x 16mm
K		φ4 x 12mm
Z		φ3 x 15mm

STEP 1

 Please screws in this step need to be tightened

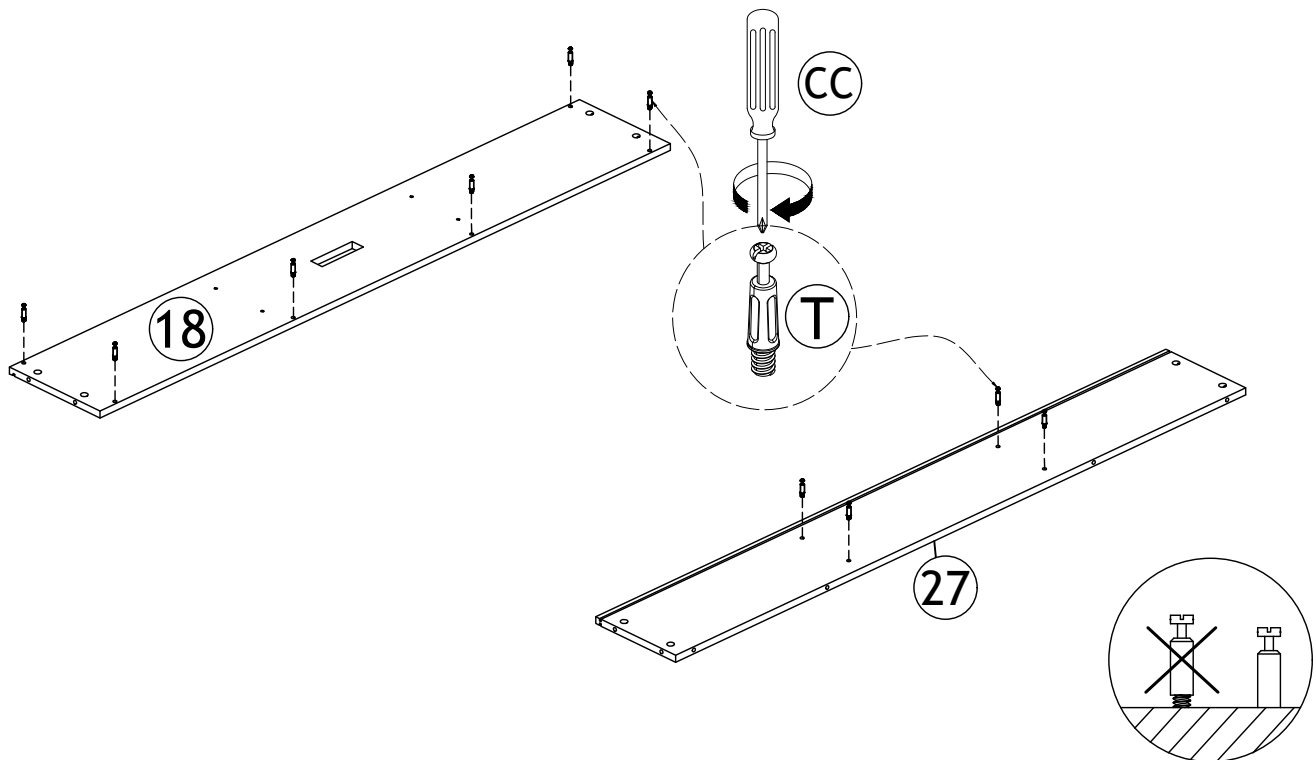
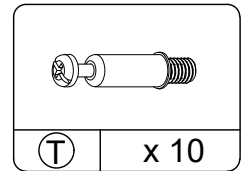
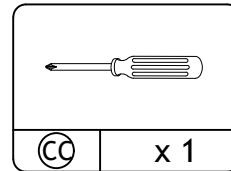

STEP 2

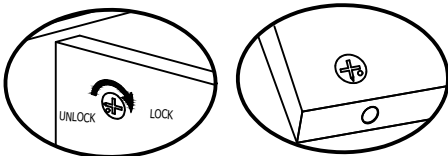

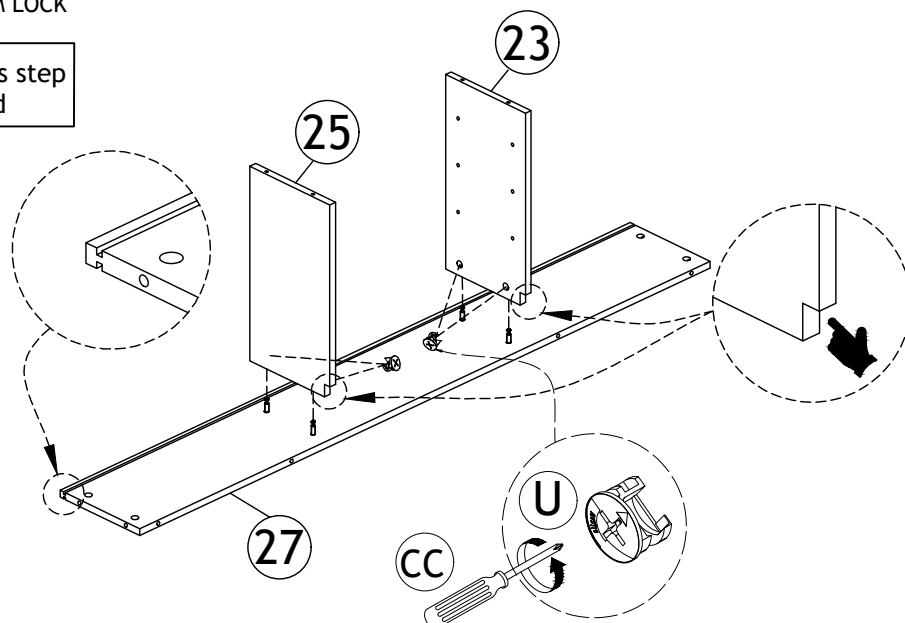
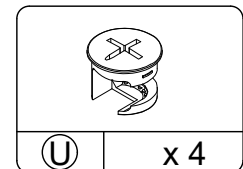
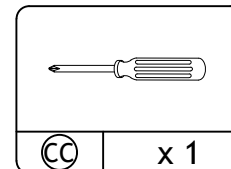

Proper orientation of CAM LOCK

 Please screws in this step need to be tightened



STEP 3

 Please screws in this step need to be tightened

	
Ø5 x 38mm	
(F)	x 4

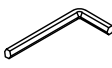
	
M3	
(V)	x 1

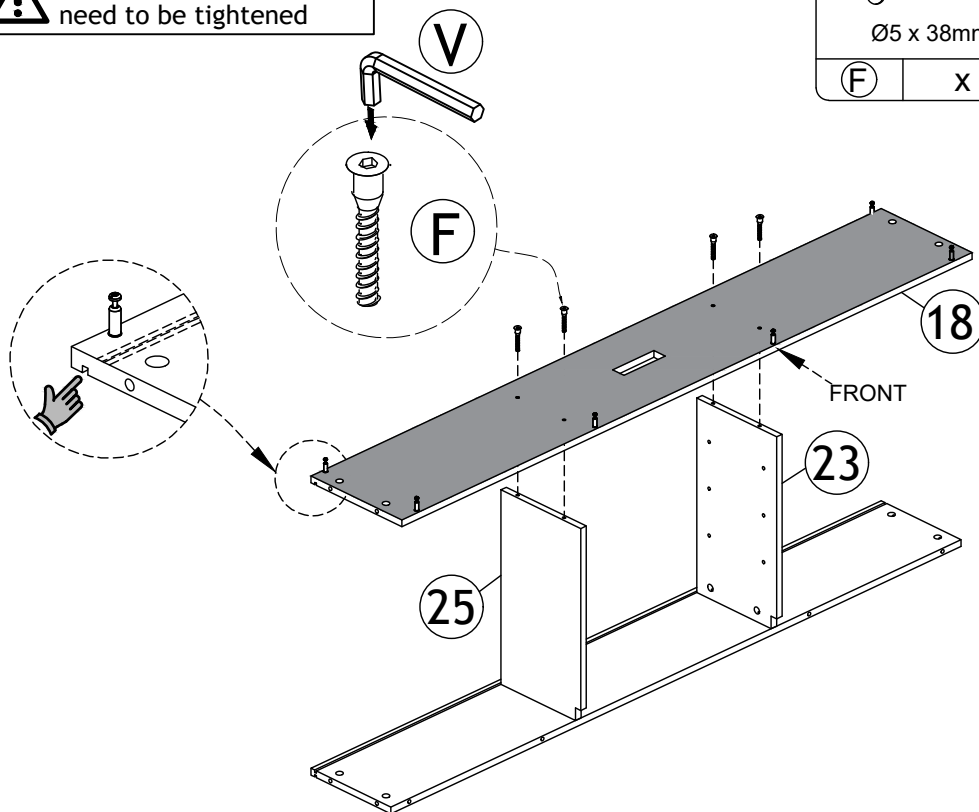

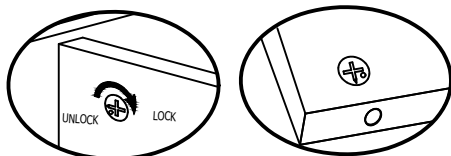

STEP 4

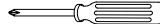

Proper orientation of CAM LOCK

	
(CC)	x 1

	
(U)	x 4

 Please screws in this step need to be tightened

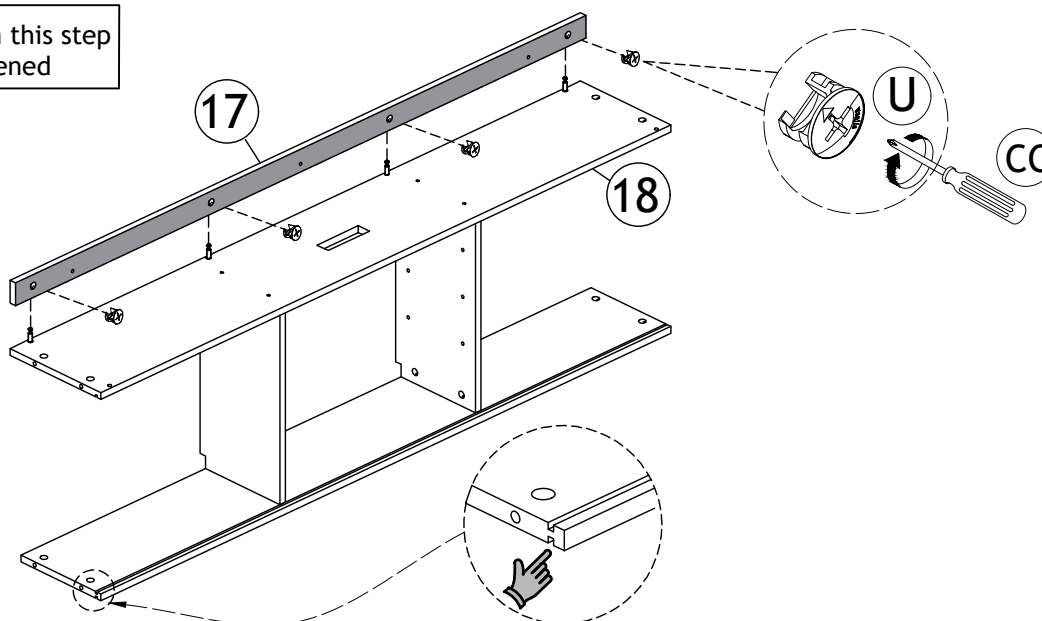

STEP 5

 Please screws in this step need to be tightened

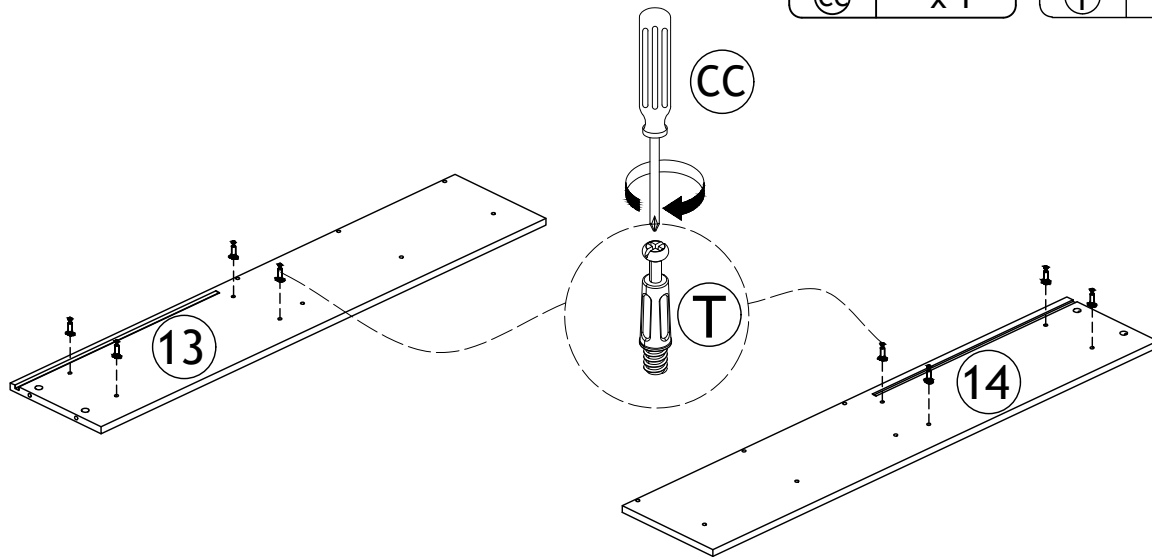
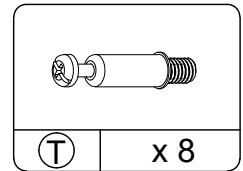
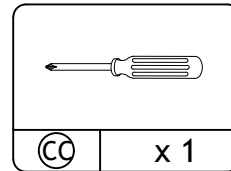

STEP 6

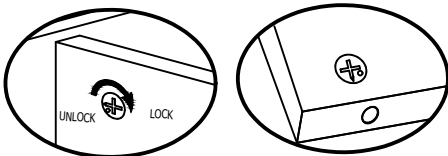

Proper orientation of CAM LOCK

 Please screws in this step need to be tightened

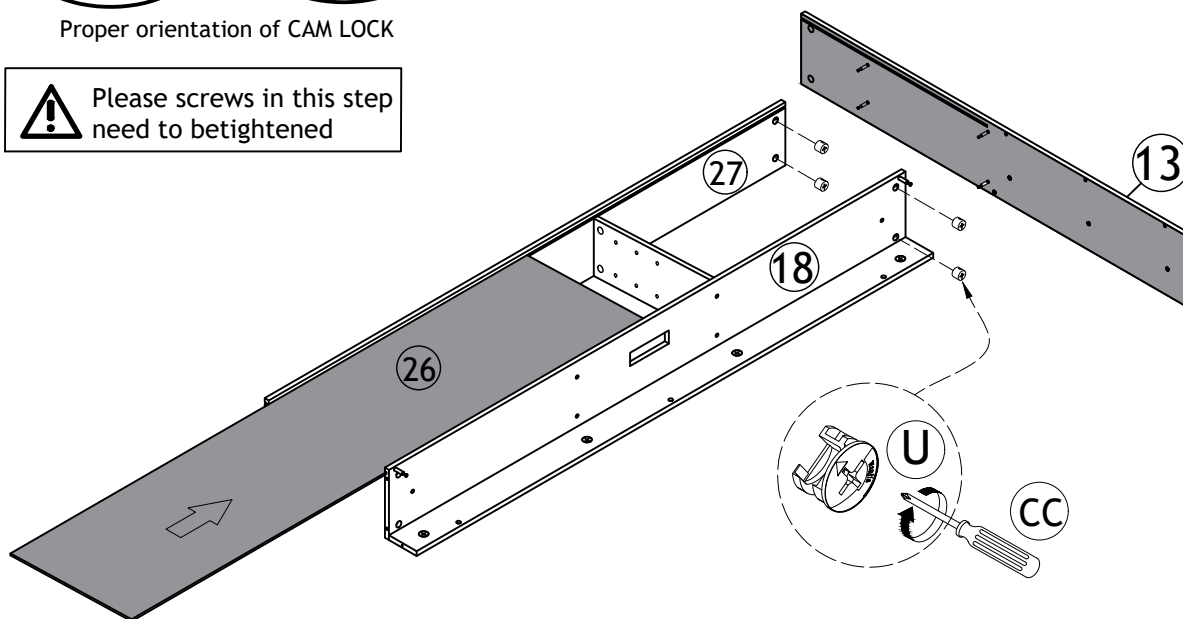
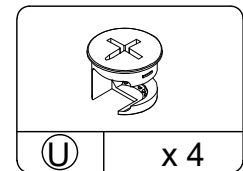
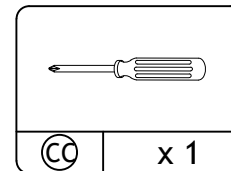

STEP 7

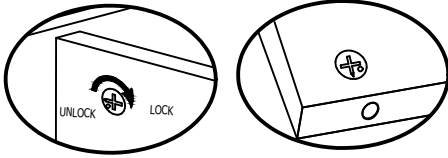

Proper orientation of CAM LOCK

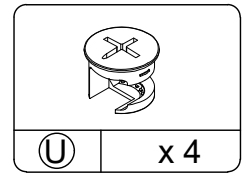
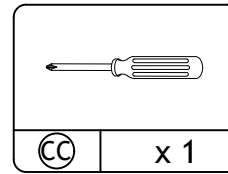

 Please screws in this step need to betightened

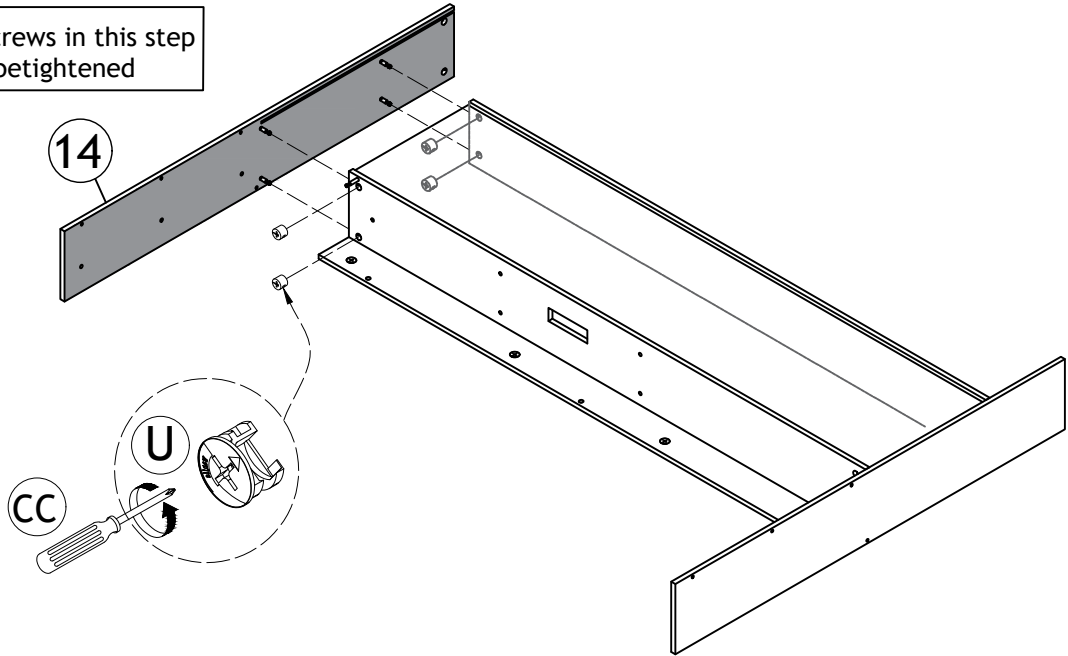

STEP 8

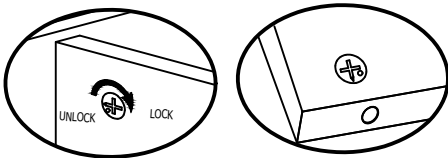

Proper orientation of CAM LOCK

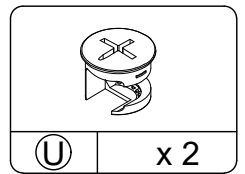
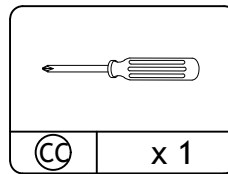

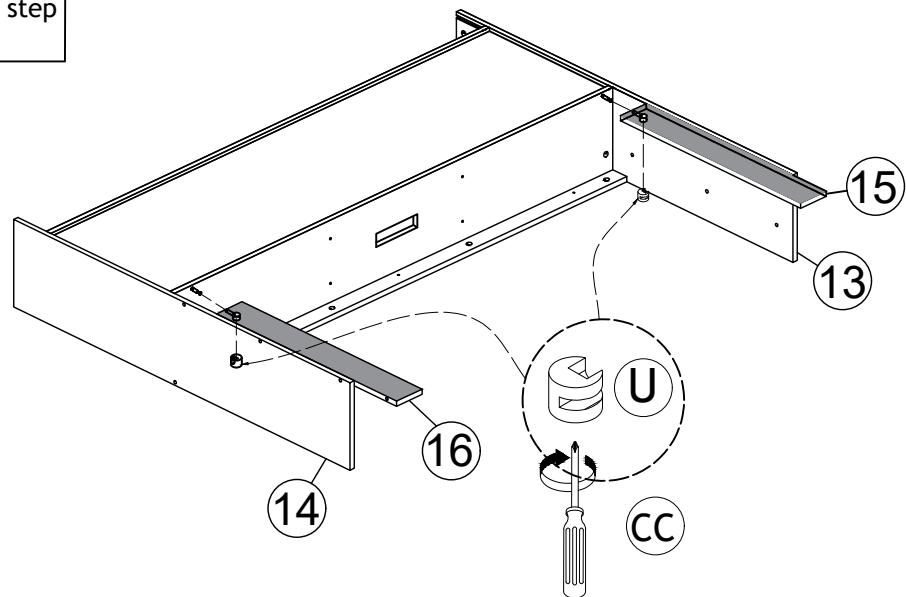

 Please screws in this step need to betightened



STEP 9

 Please screws in this step need to be tightened

	
Ø5 x 38mm	
(F)	x 8

	
M3	
(V)	x 1

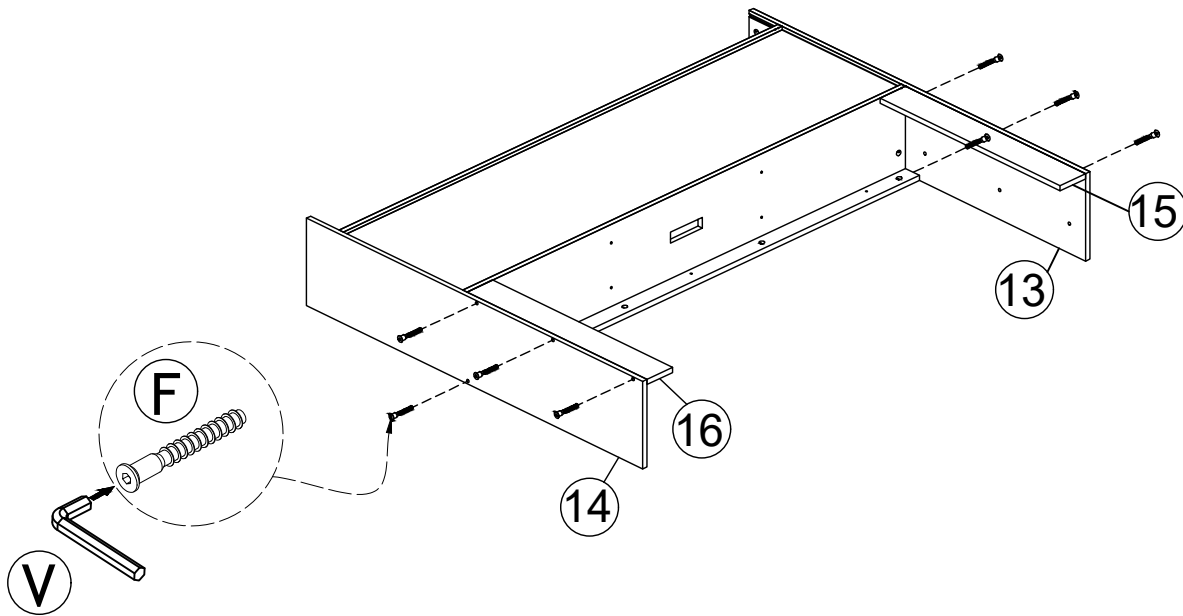



STEP 10

 Please tighten the bolts to 80% first, and tighten all bolts 100% after all parts are assembled.

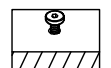



	
Ø1/4" x 11mm	
(B)	x 6

	
M4	
(AA)	x 1

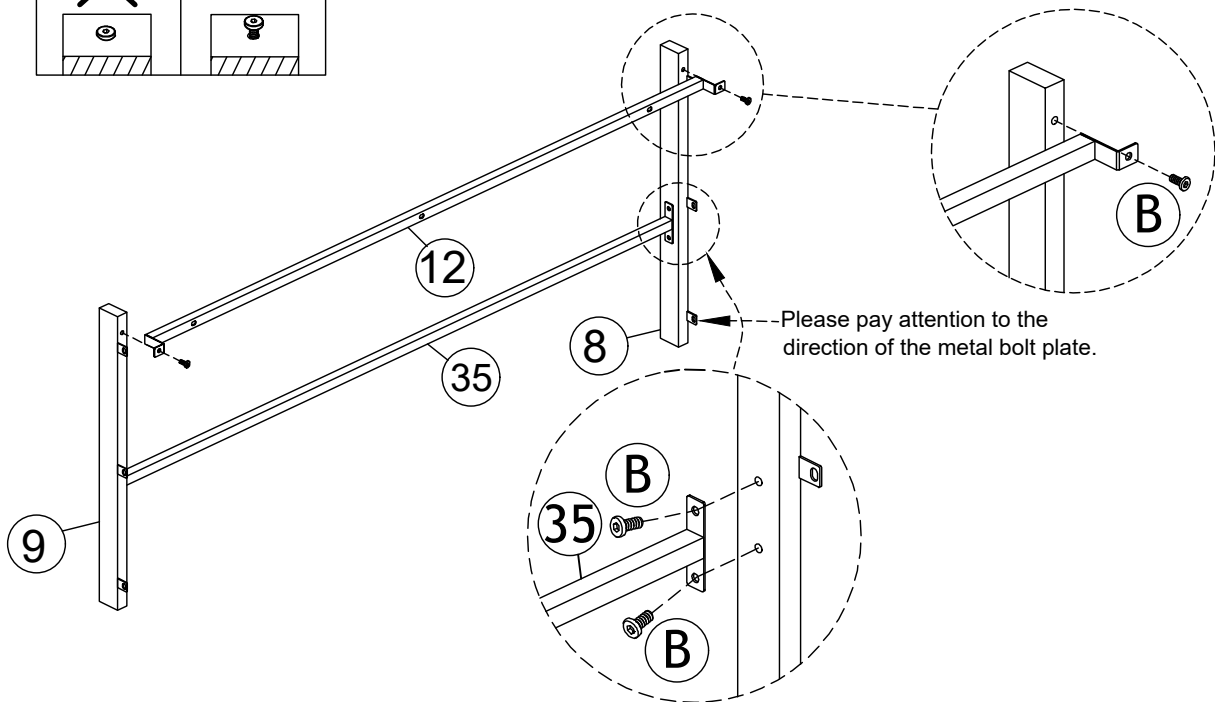

STEP 11

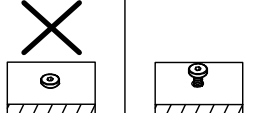
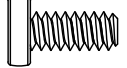

 Please tighten the bolts to 80% first, and tighten all bolts 100% after all parts are assembled.

Ø1/4" x 28mm
(C) x 3



Ø1/4" x 11mm
(B) x 6



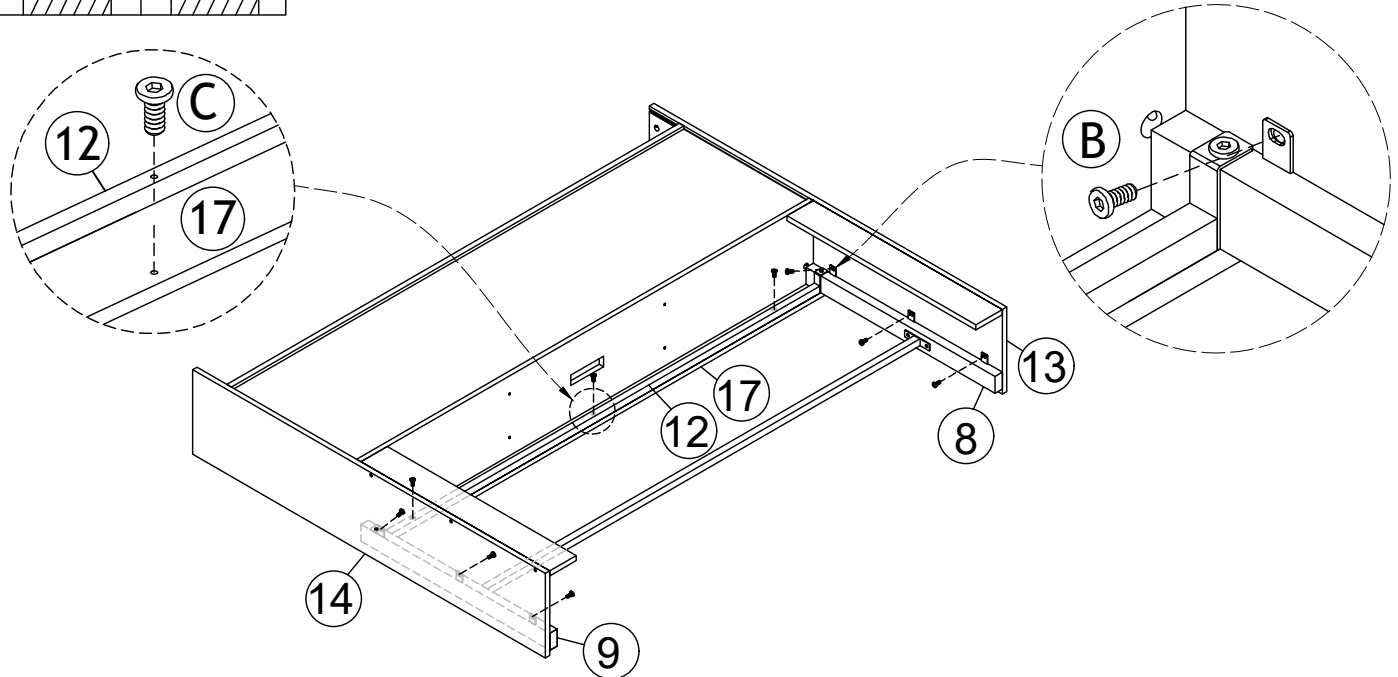

M4
(AA) x 1



STEP 12

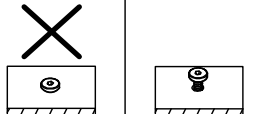

 Please tighten the bolts to 80% first, and tighten all bolts 100% after all parts are assembled.

Ø5 x 38mm
(F) x 4

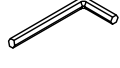

M3
(V) x 1

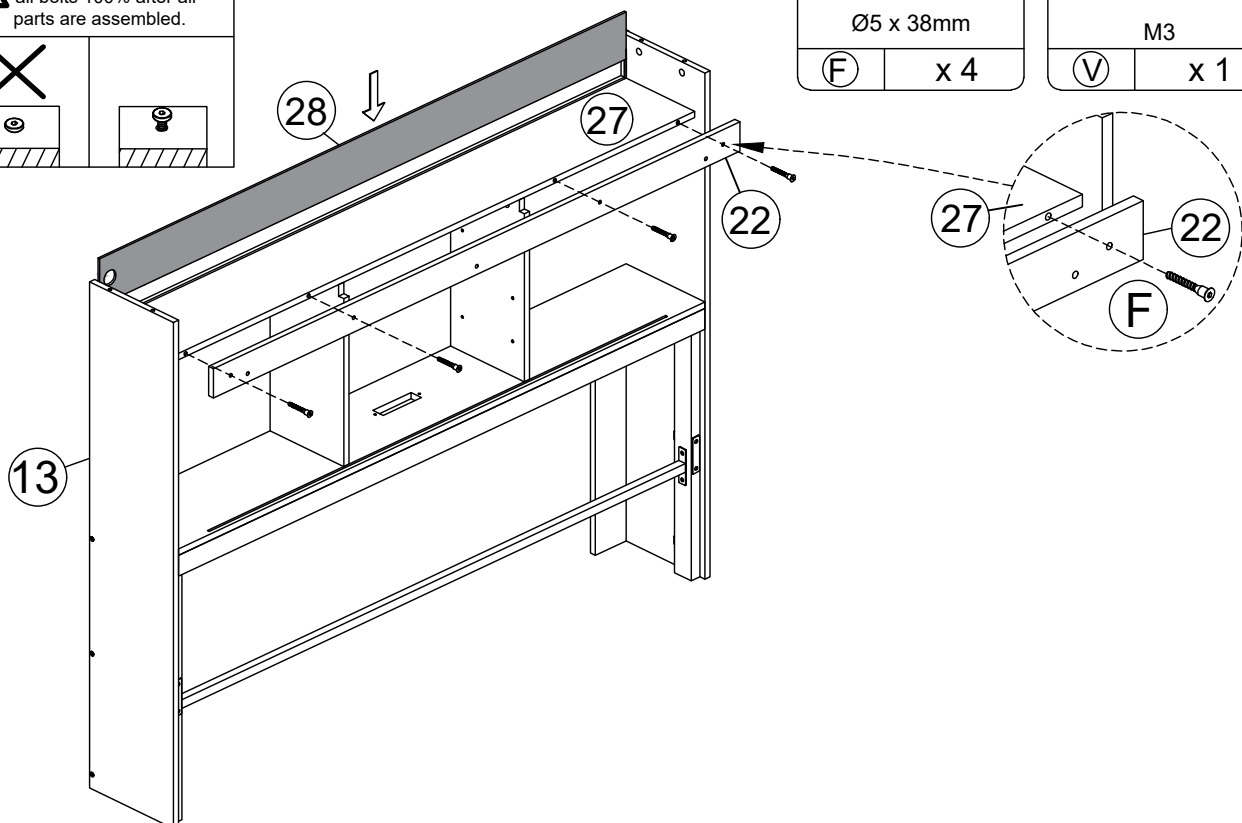

STEP 13

 Please screws in this step need to be tightened

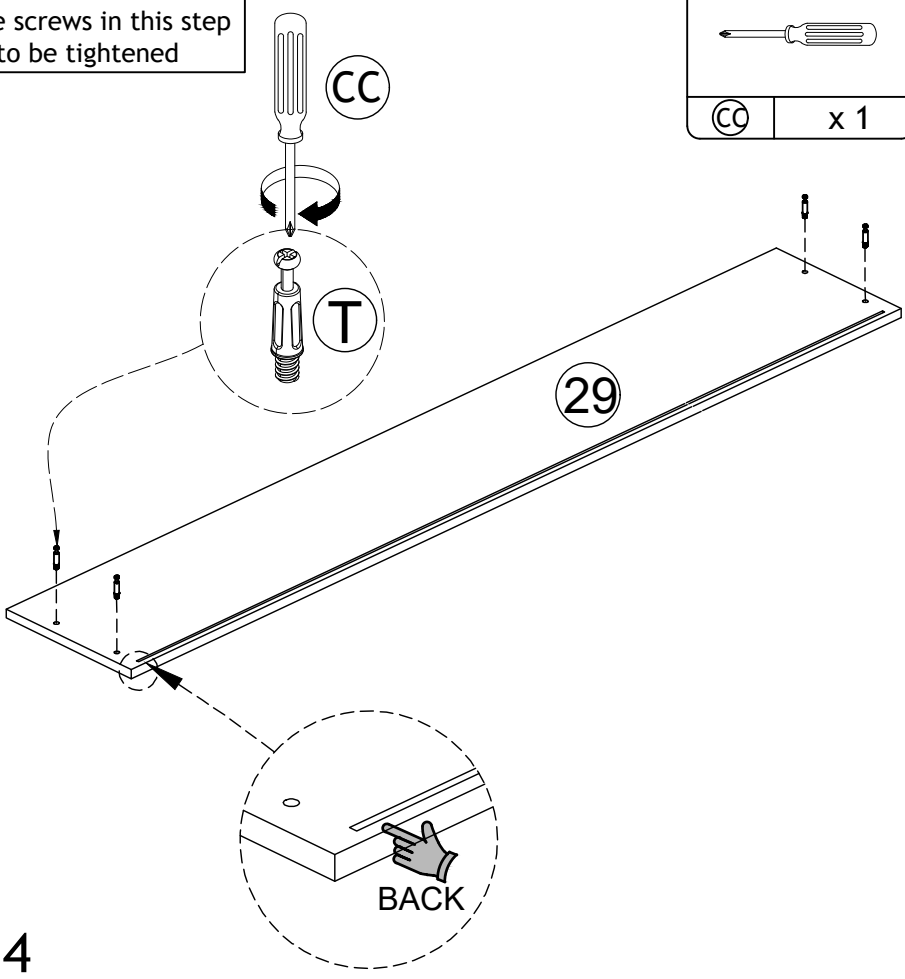
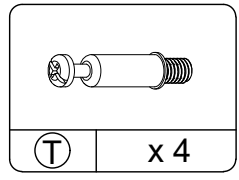
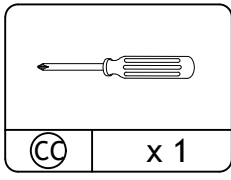

STEP 14

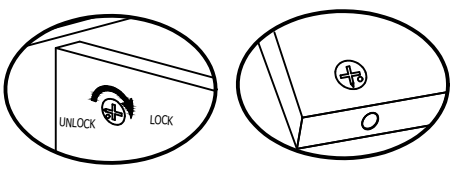

Proper orientation of CAM LOCK

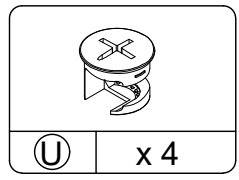
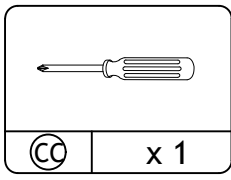

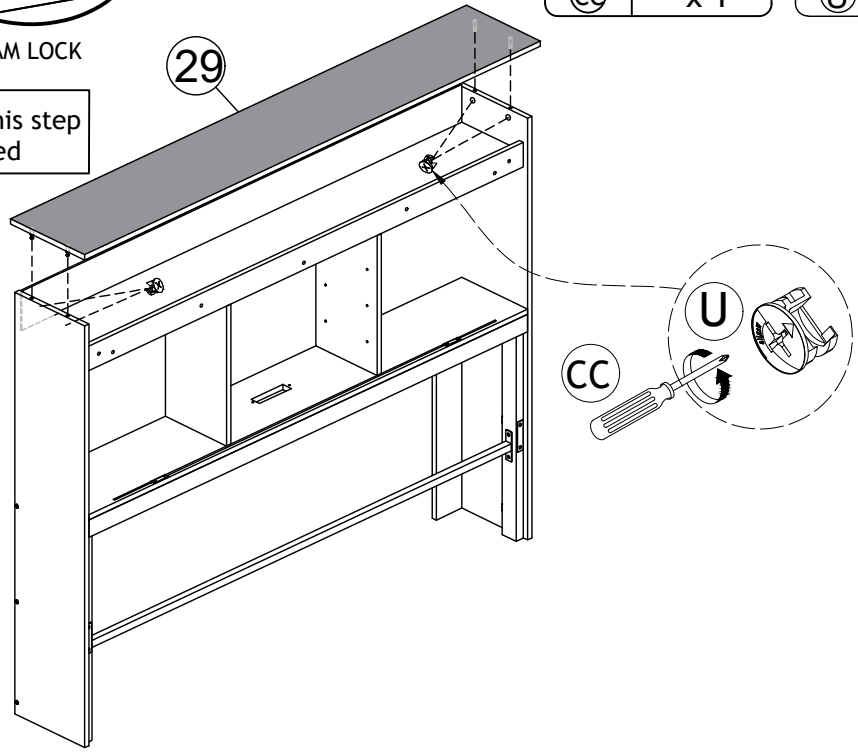

 Please screws in this step need to be tightened

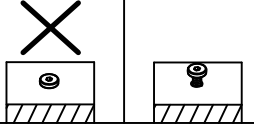

STEP 15

 Please tighten the bolts to 80% first, and tighten them all when all parts are assembled.



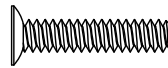

(P)	x 3
-----	-----



Ø1/4" x 28mm

(D)	x 3
-----	-----



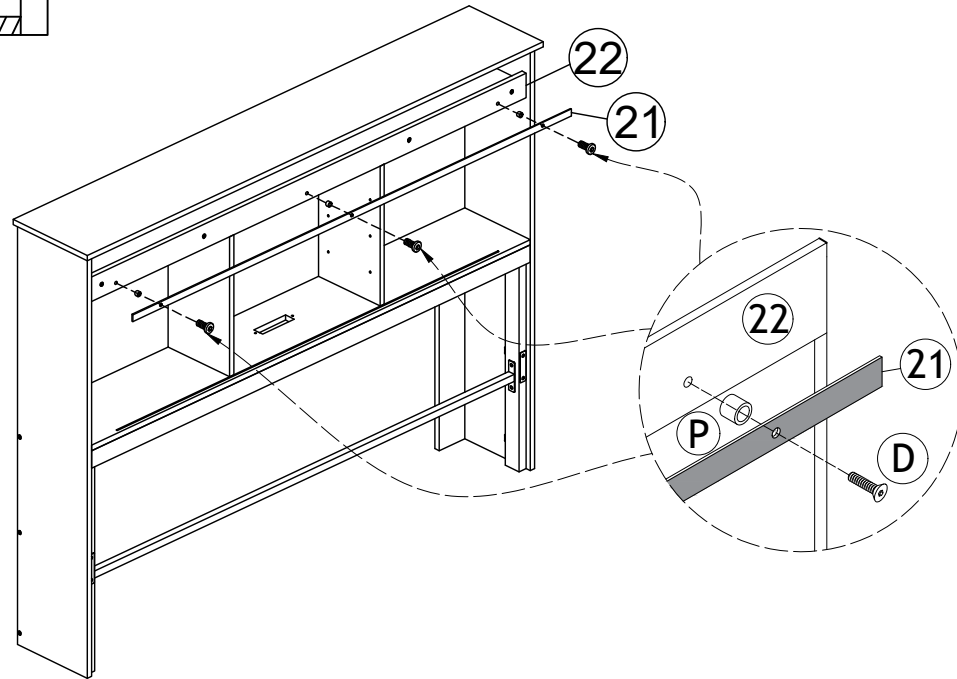

M4

(AA)	x 1
------	-----



STEP 16

 Please screws in this step need to be tightened



(CC)	x 1
------	-----

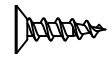

Ø3 x 15mm

(Z)	x 6
-----	-----



(W)	x 6
-----	-----

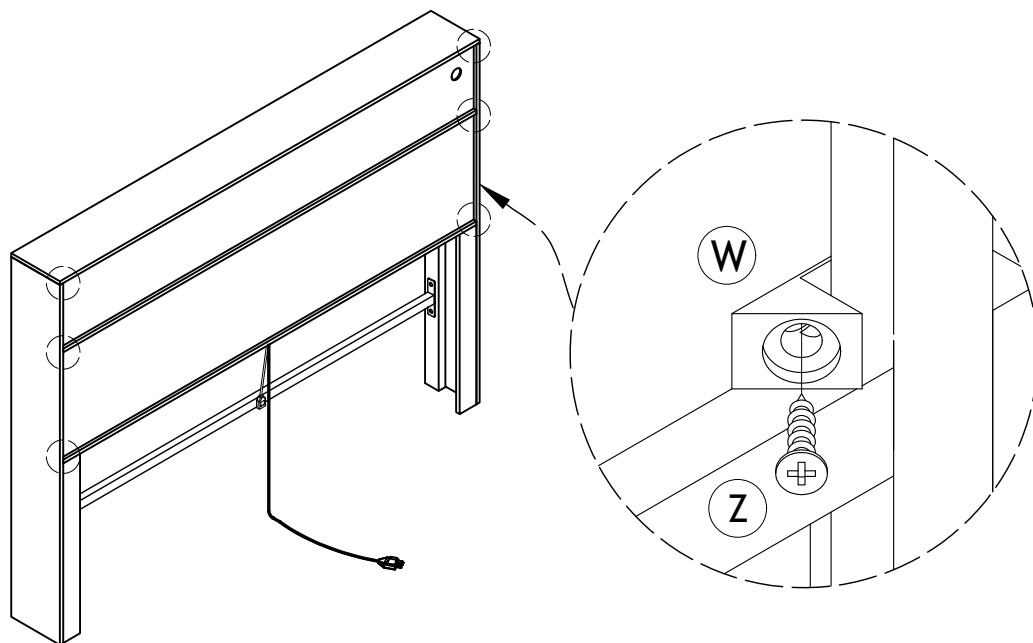

STEP 17

 Please screws in this step need to be tightened

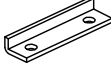

(C) x 1

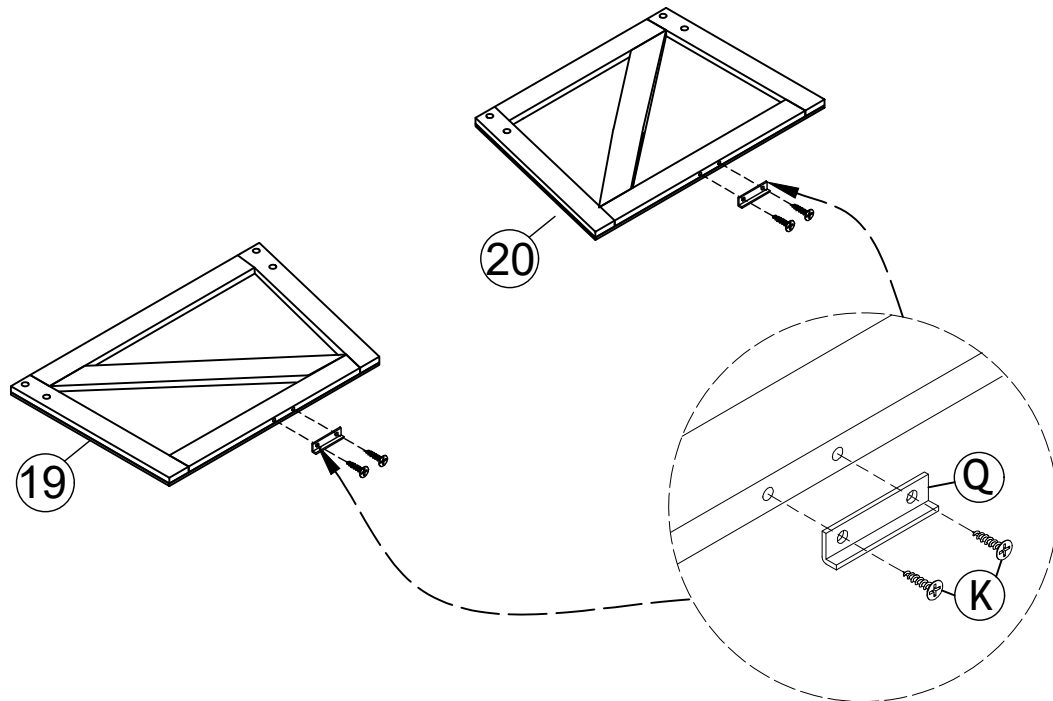

(Q) x 2



Ø4 x 12mm
(K) x 4



STEP 18

 Please tighten the bolts to 80% first, and tighten all bolts 100% after all parts are assembled.

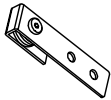

	
---	---

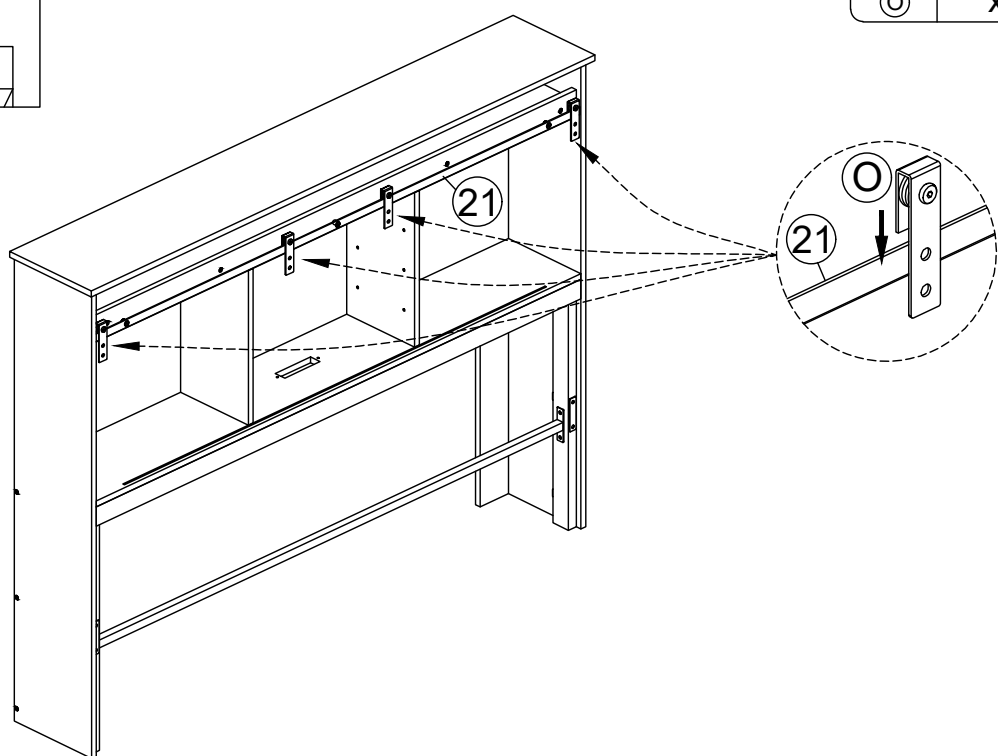

(O) x 4



STEP 19

 Please tighten the bolts to 80% first, and tighten all bolts 100% after all parts are assembled.

	
---	---

Ø1/4" x 11mm
(B) x 8

M4
(AA) x 1

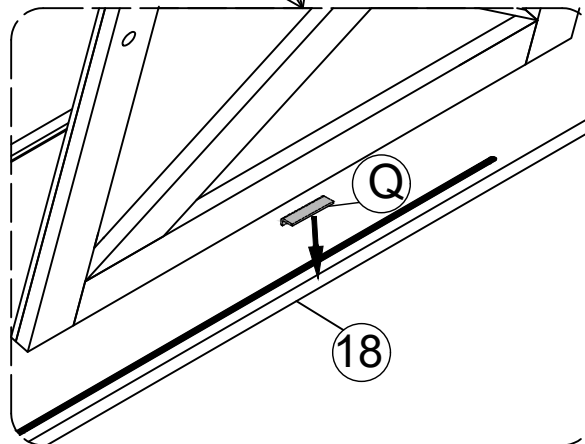
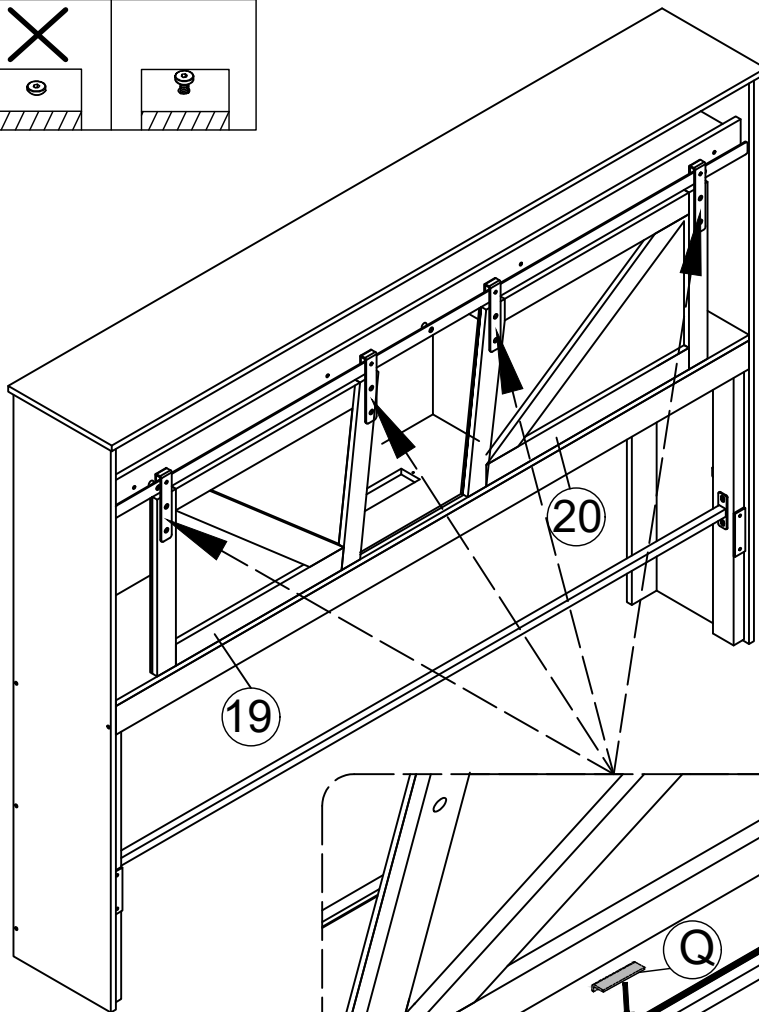

Insert metal plates (Q) under door (19/20) into the groove on panel (18).

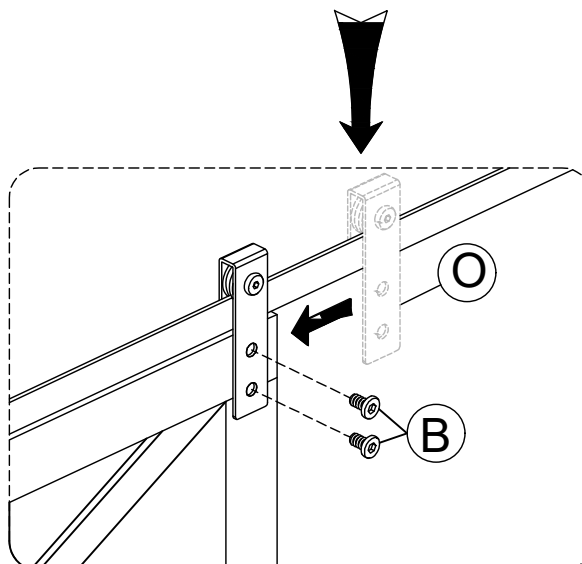



Connect door (19/20) metal pulley (O) with bolt (B).

STEP 20

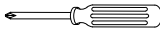
 Please screws in this step need to be tightened

	
(CC)	x 1

	
Ø4 x 12mm	
(K)	x 2

	
(X)	x 1

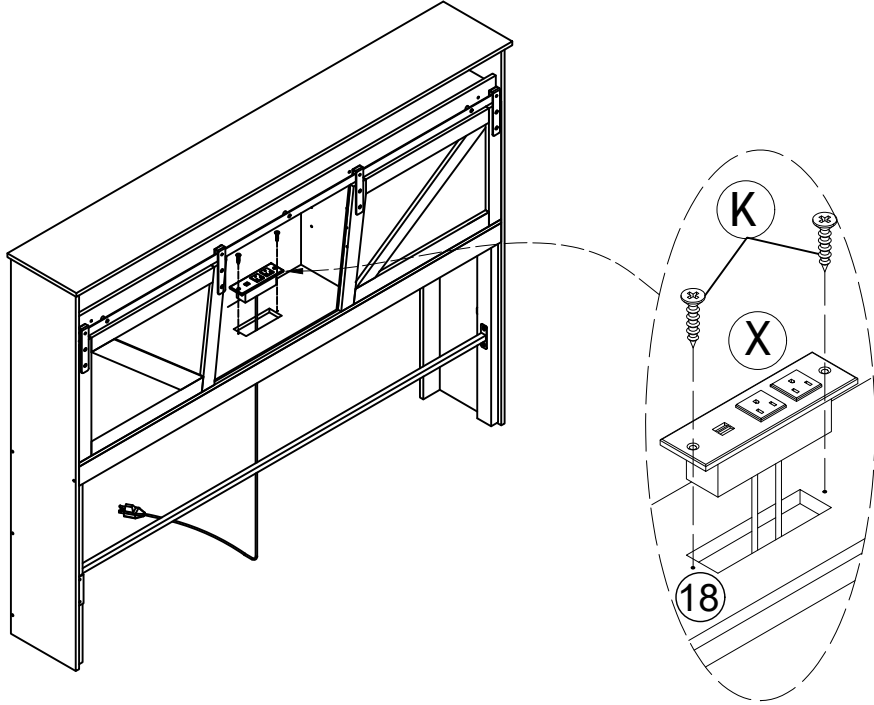

STEP 21

 Please tighten the bolts to 80% first, and tighten all bolts 100% after all parts are assembled.



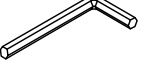

	
Ø1/4" x 16mm	
(H)	x 4

	
M4	
(AA)	x 1

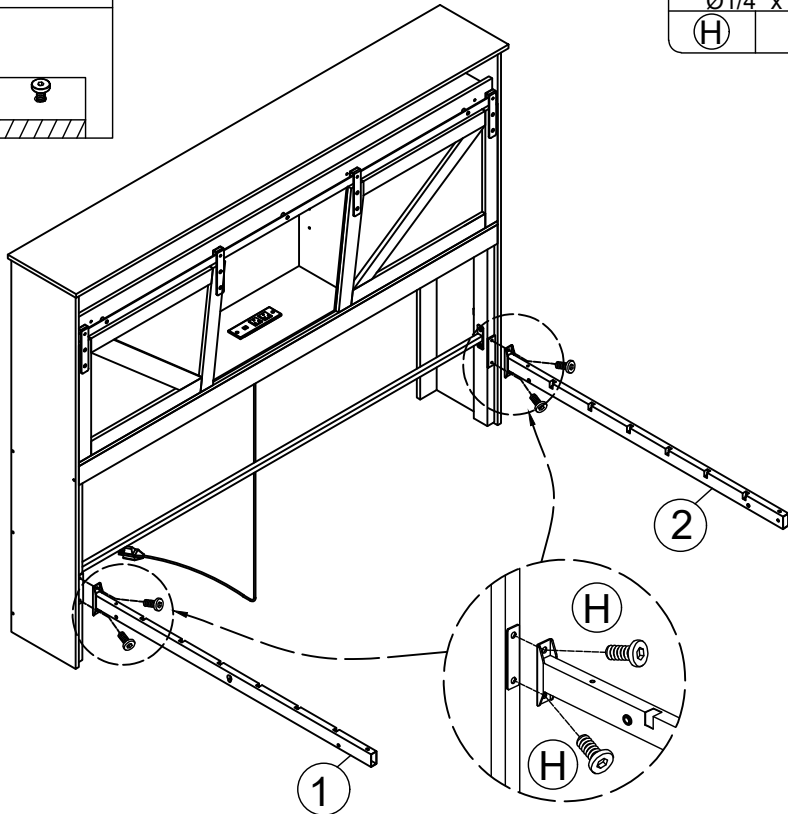

STEP 22

 Please screws in this step need to be tightened

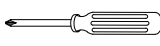
	
CC	x 1

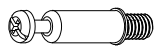
	
T	x 4

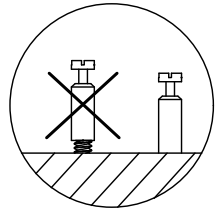
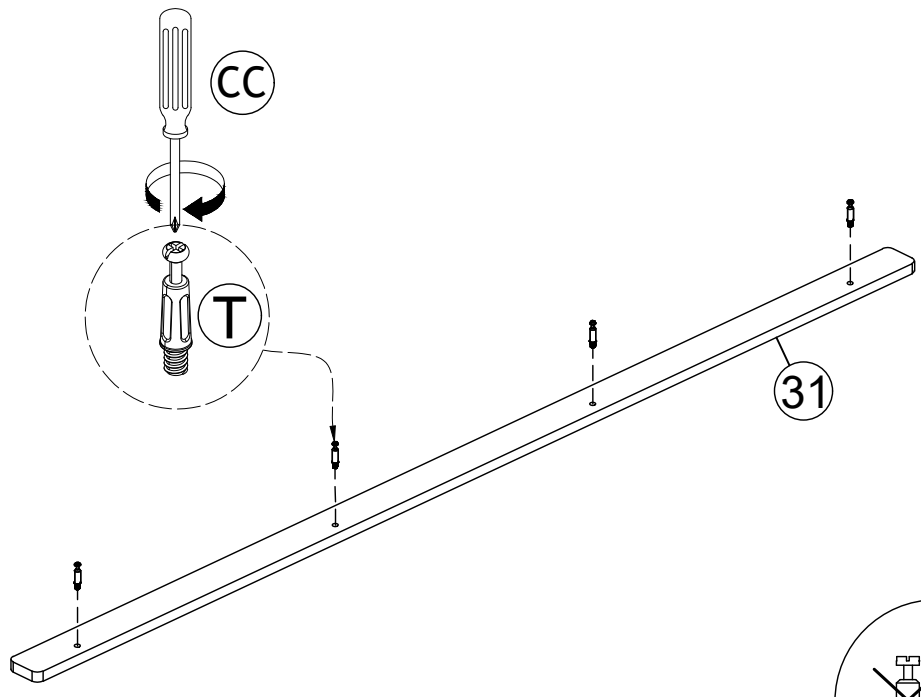

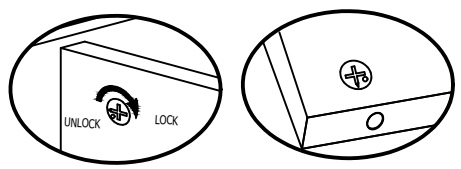

STEP 23

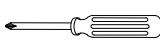

Proper orientation of CAM LOCK

 Please screws in this step need to be tightened

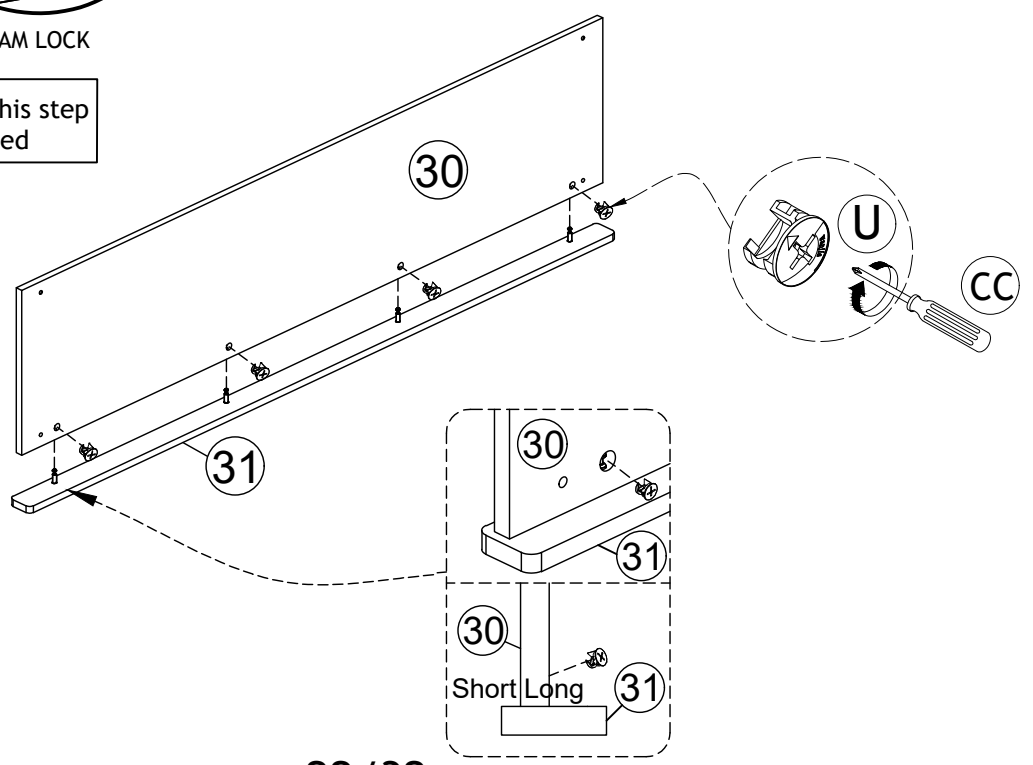

	
CC	x 1

	
U	x 4



STEP 24

 Please tighten the bolts to 80% first, and tighten all bolts 100% after all parts are assembled.

	
---	---



Ø1/4" x 11mm
(B) x 4

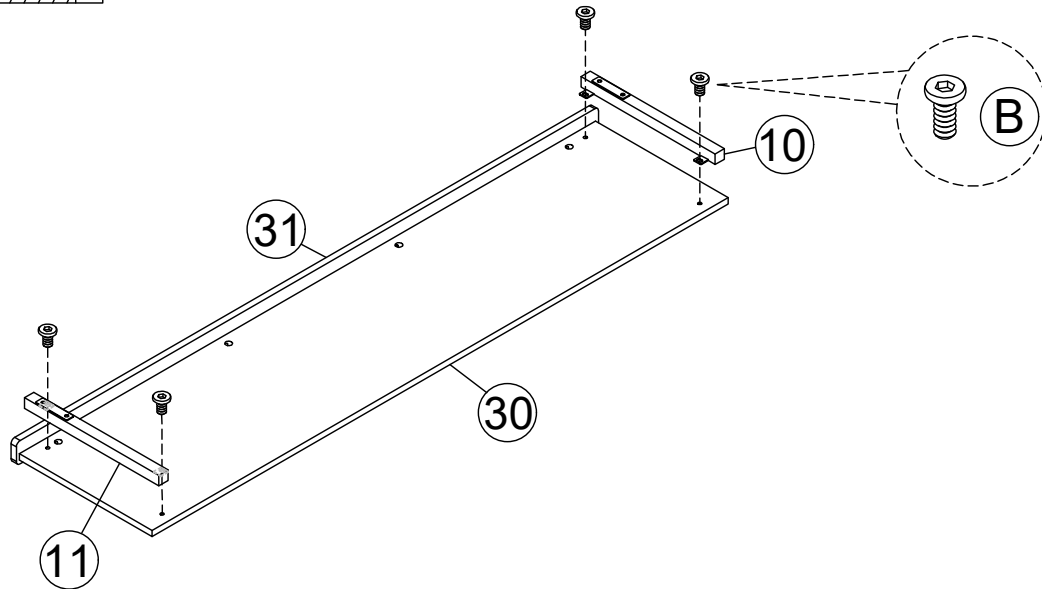

M4
(AA) x 1



STEP 25

 Please tighten the bolts to 80% first, and tighten all bolts 100% after all parts are assembled.

	
---	---

Ø1/4" x 16mm
(H) x 4

M4
(AA) x 1

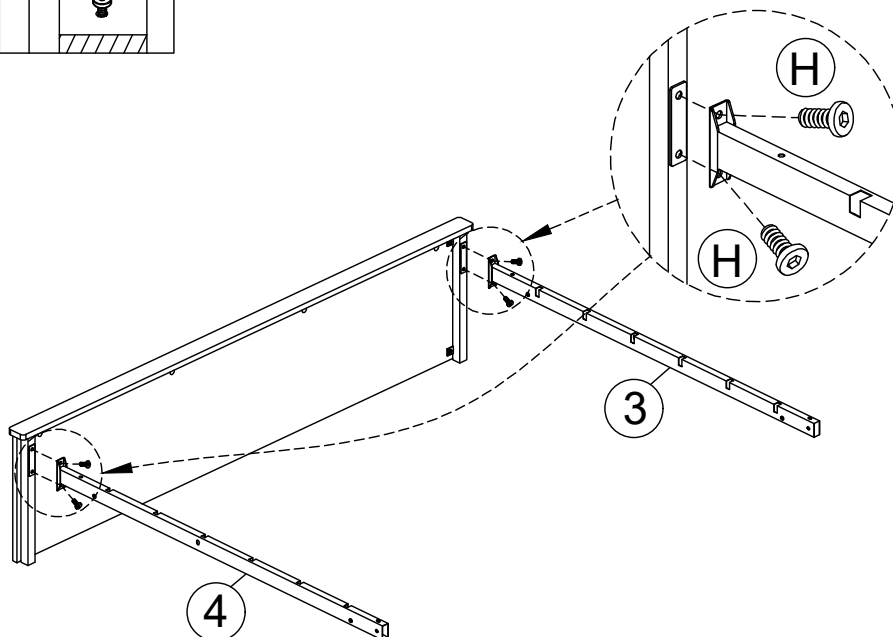

STEP 26

Please tighten the bolts to 80% first, and tighten all bolts 100% after all parts are assembled.

Ø1/4" x 16mm
(H) x 4

M8 x 50mm
(I) x 4

M4
(AA) x 1

M5
(BB) x 1

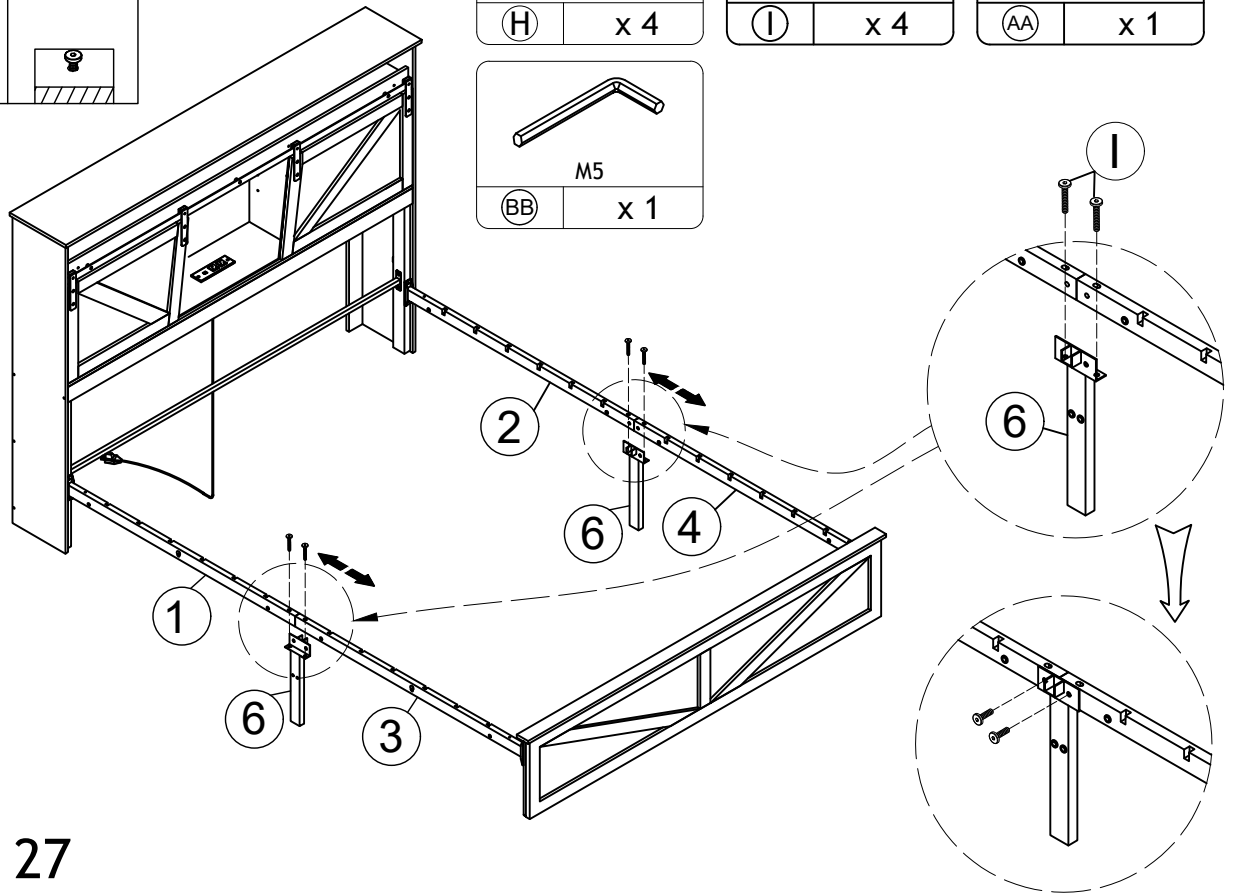

STEP 27

Please tighten the bolts to 80% first, and tighten all bolts 100% after all parts are assembled.

Ø1/4" x 11mm
(B) x 4

M4
(AA) x 1

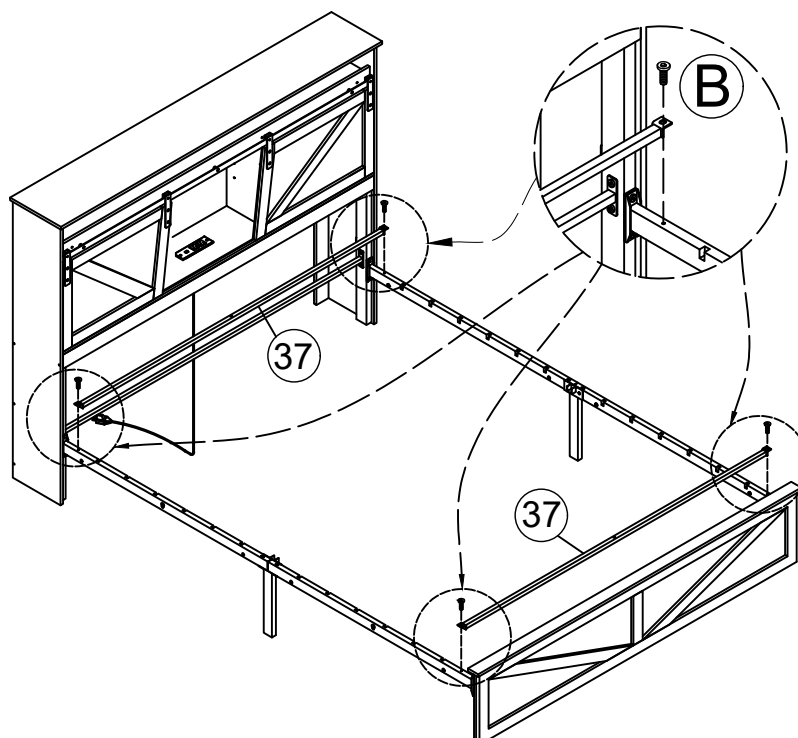

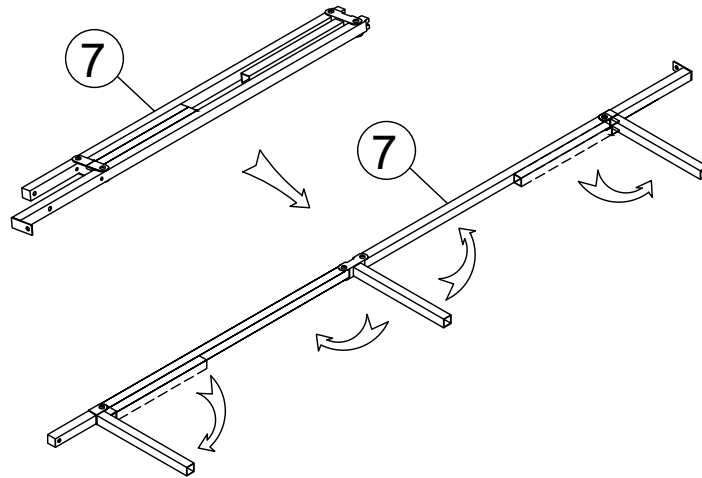

STEP 28





Expand the folded portion

STEP 29

 Please tighten the bolts to 80% first, and tighten all bolts 100% after all parts are assembled.

	
---	---



Ø1/4" x 11mm
(B) x 1

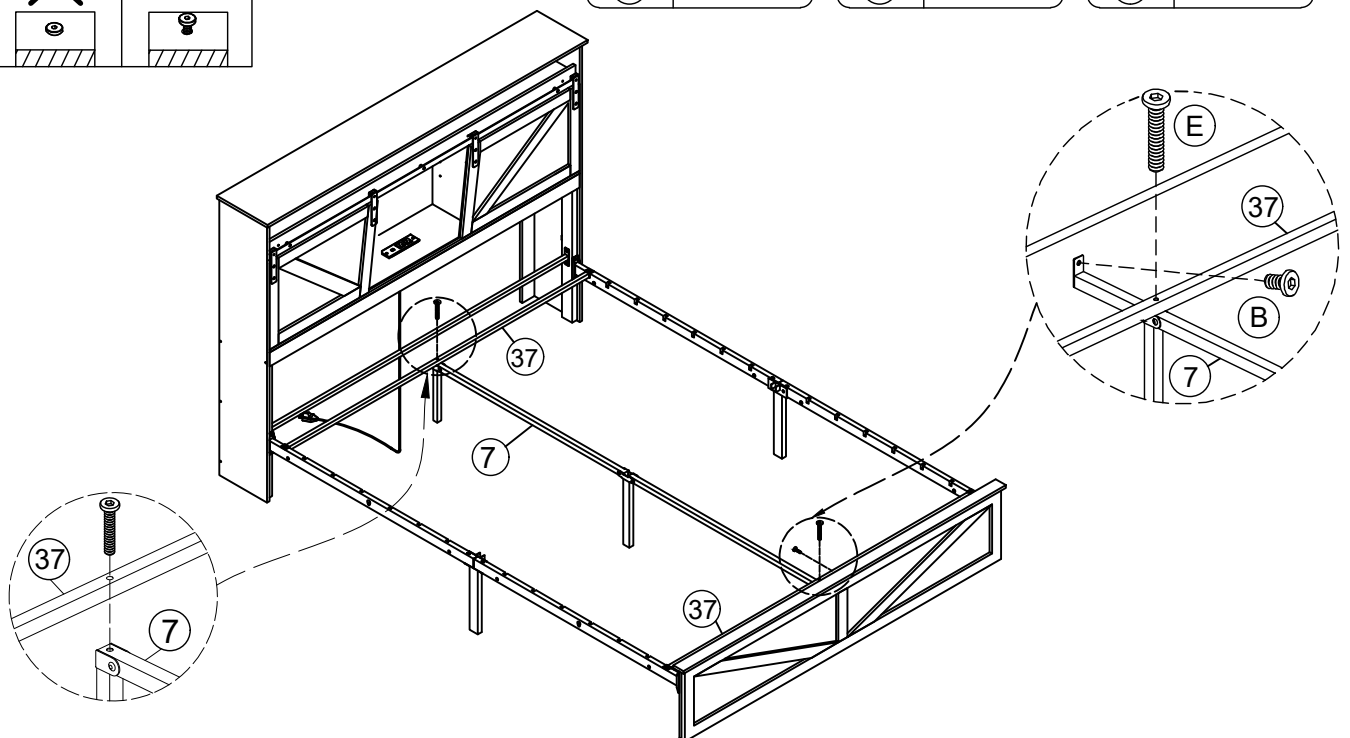

1/4" x 50mm
(E) x 2

M4
(AA) x 1

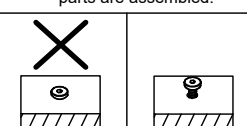

STEP 30

 Please tighten the bolts to 80% first, and tighten all bolts 100% after all parts are assembled.

M8 x 28mm

(A) x 2



Ø1/4" x 50mm

(E) x 1



M4

(AA) x 1



M5

(BB) x 1

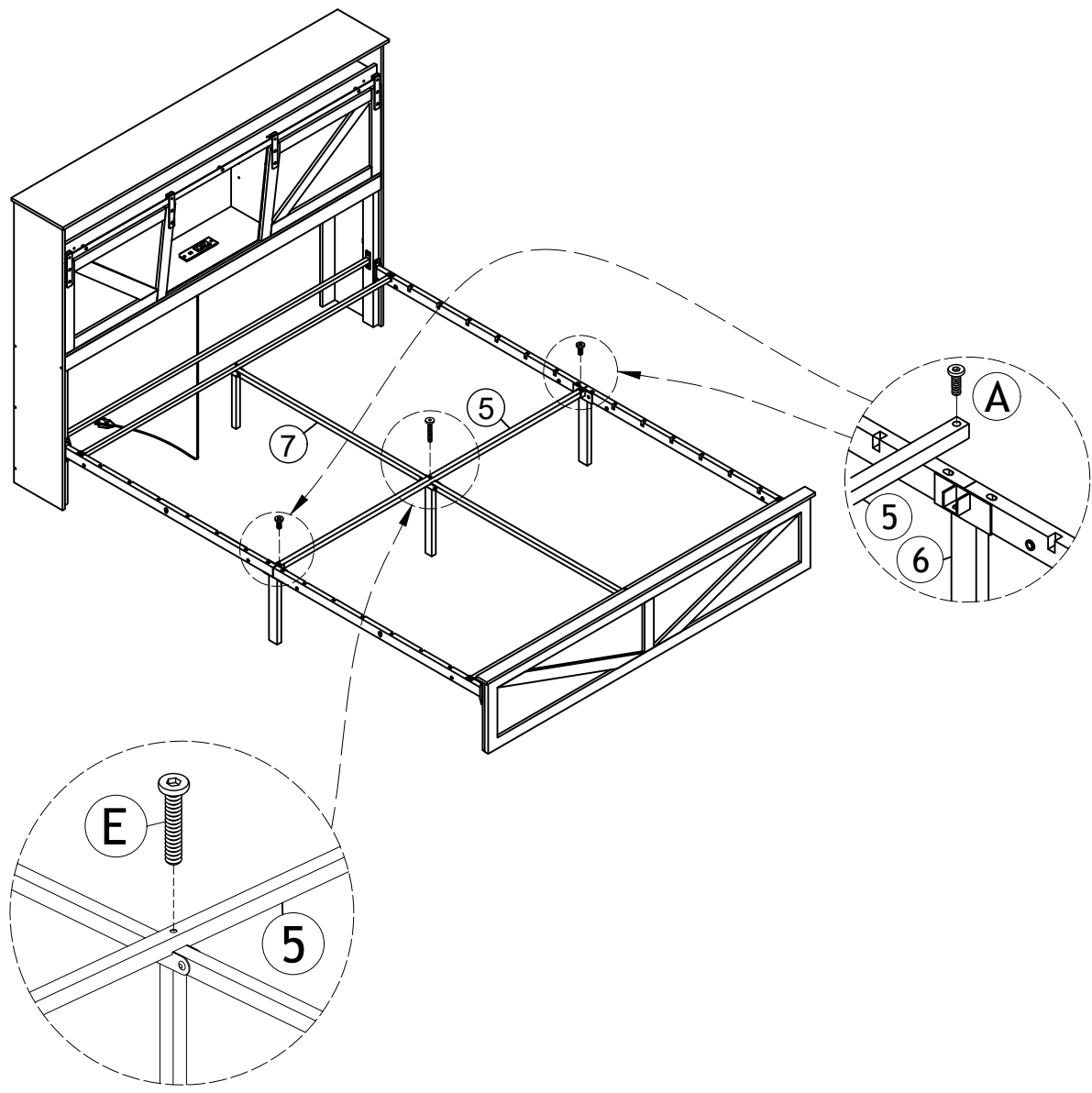

STEP 31

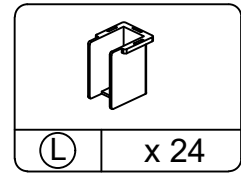
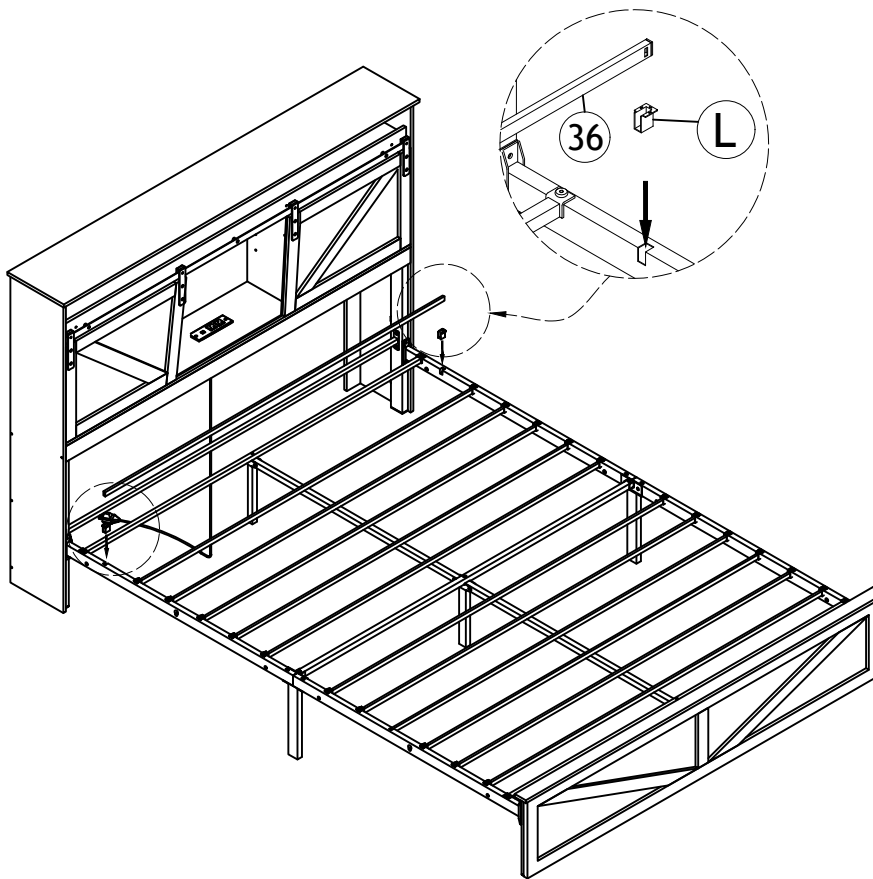

Assemble the slats

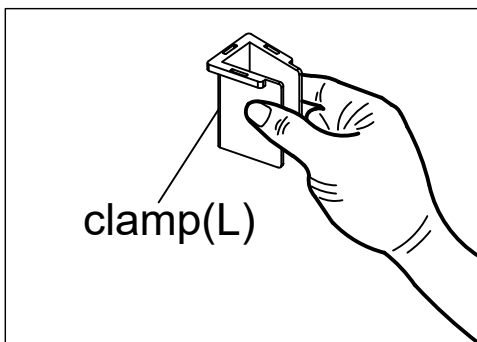

1. Squeeze the clamp (L) tightly.

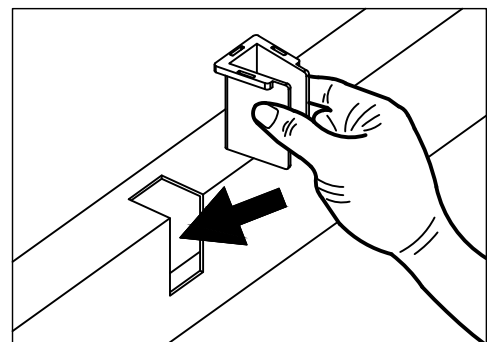

2. Put the clamp into the gaps.

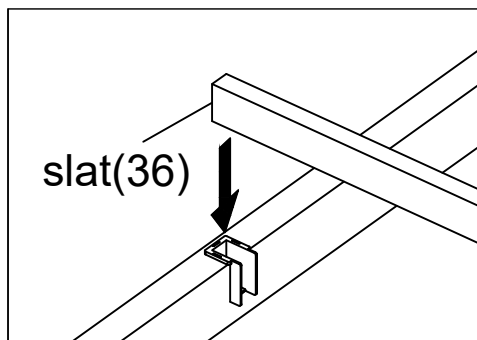

3. Put the slat (36) into the clamp.

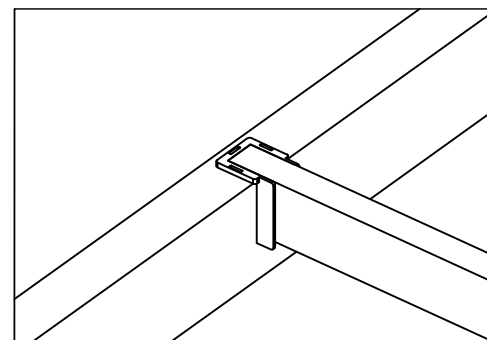

4. Finished.

STEP 32

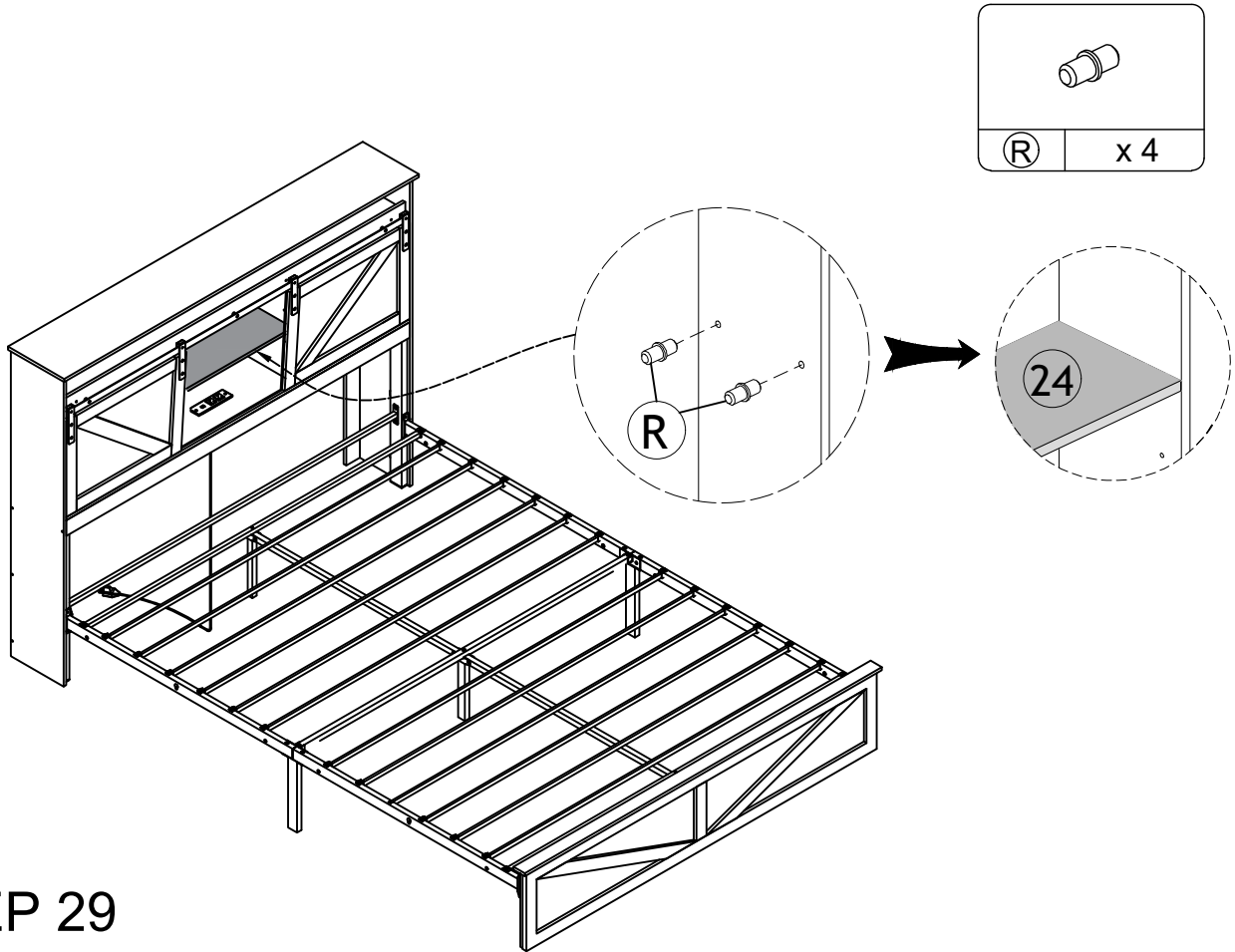

STEP 29 STEP 33

Expand the drawer frame

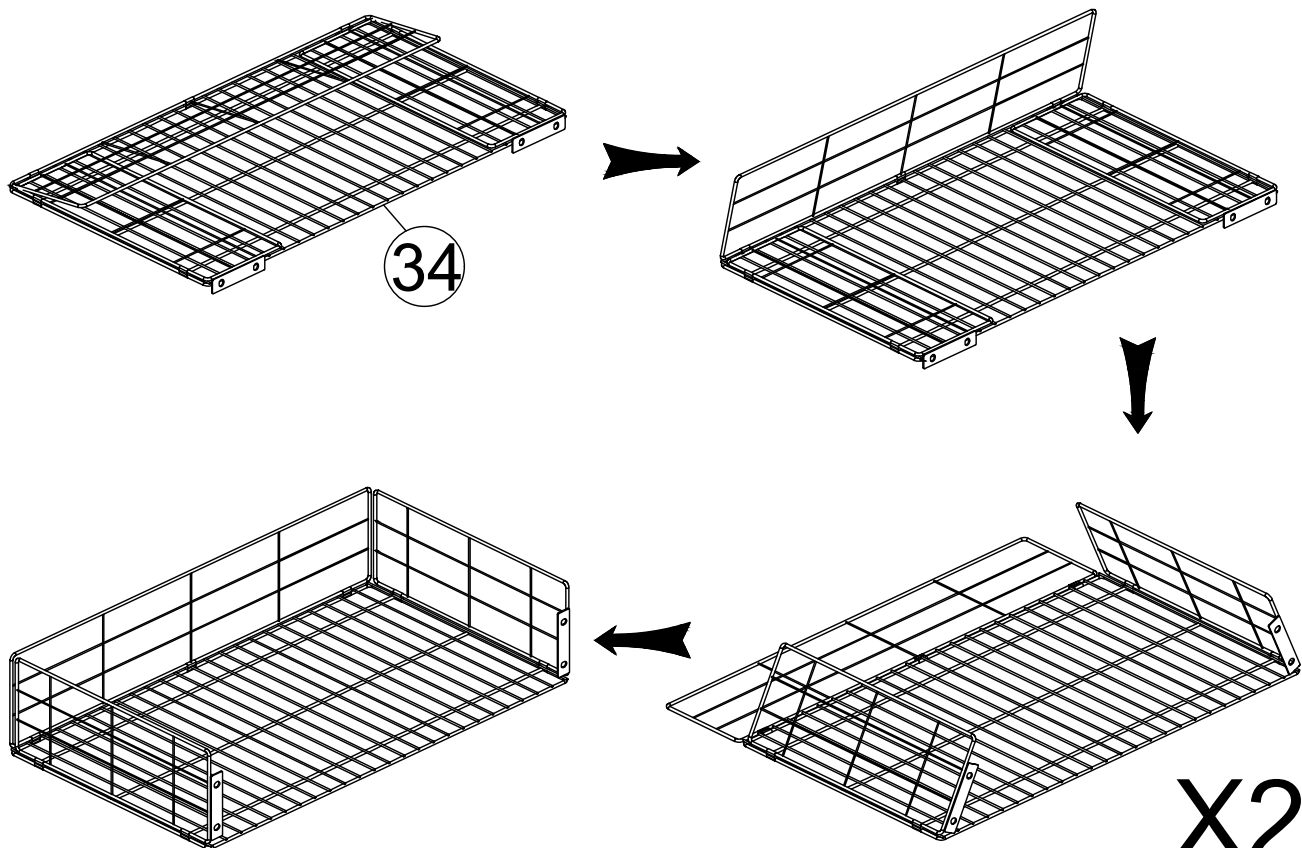

STEP 34

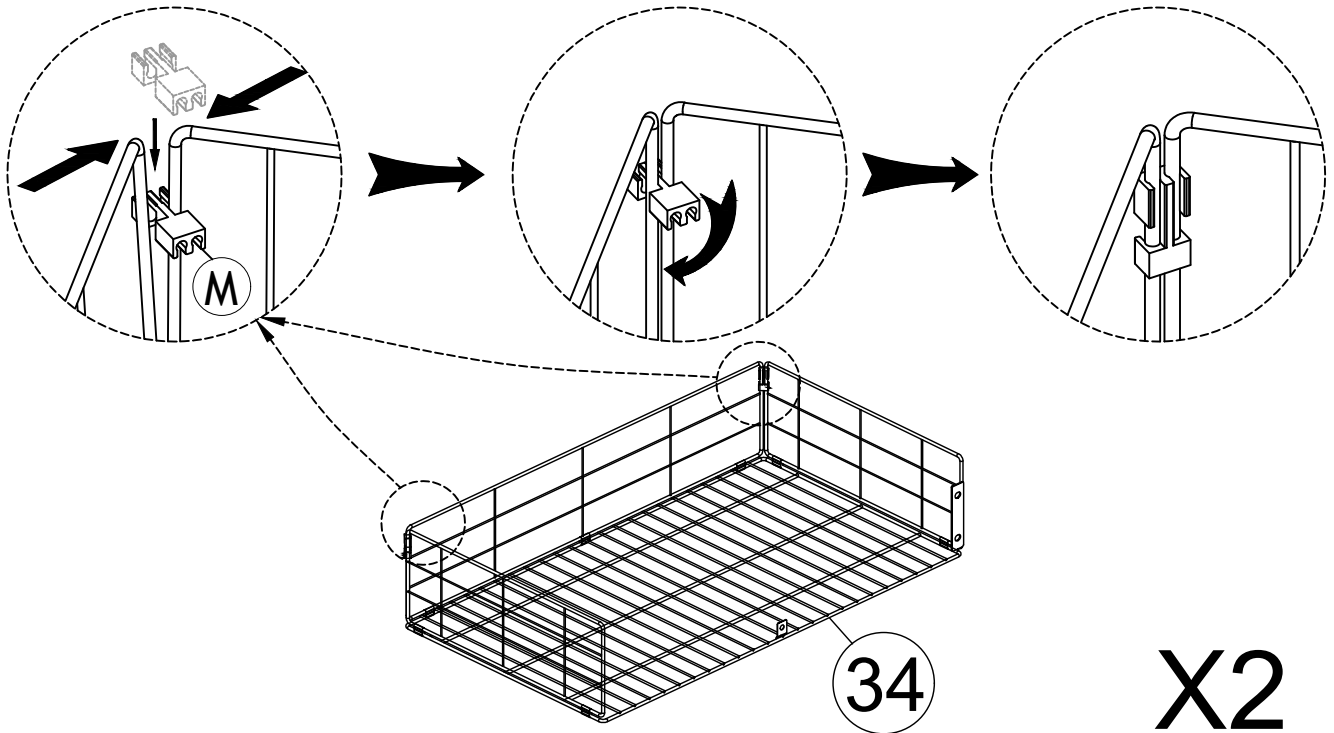
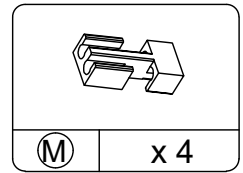

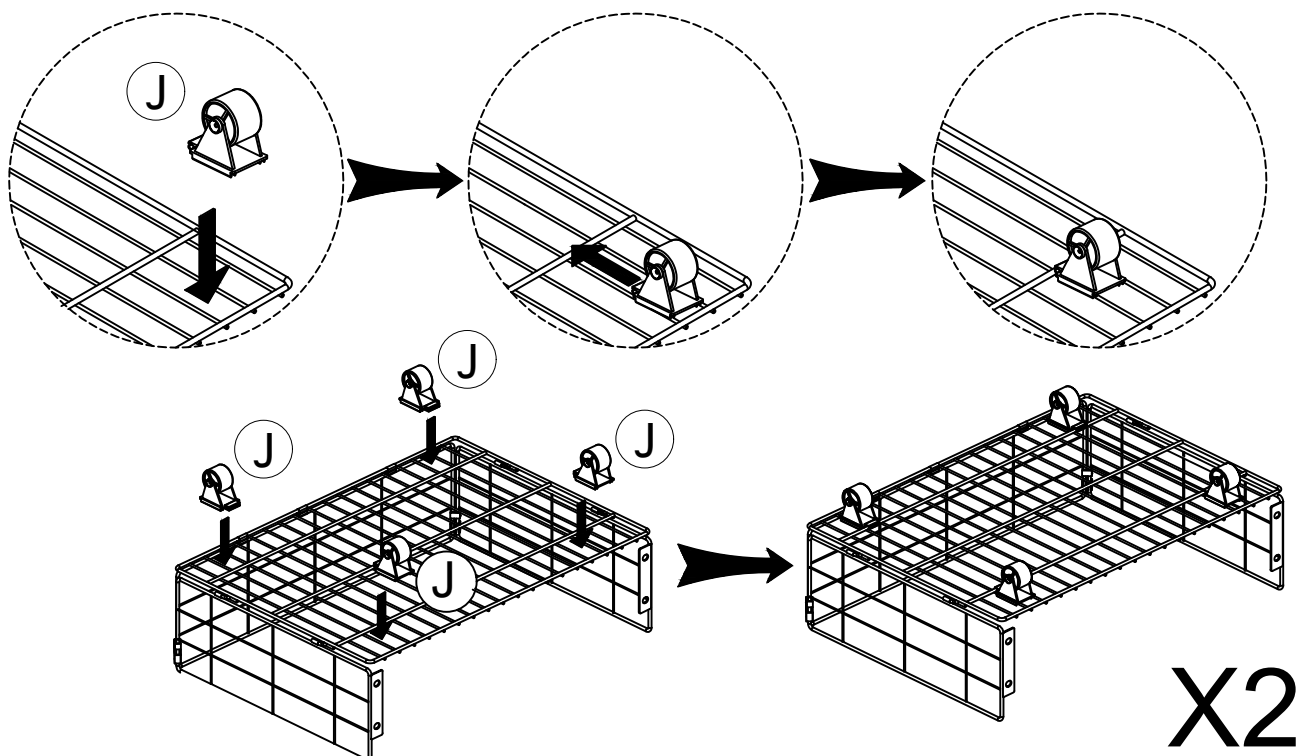
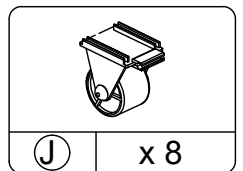

STEP 35



STEP 36

 Please screws in this step need to be tightened

	Ø1/4" x 11mm
(B)	x 8

	M4
	x 1

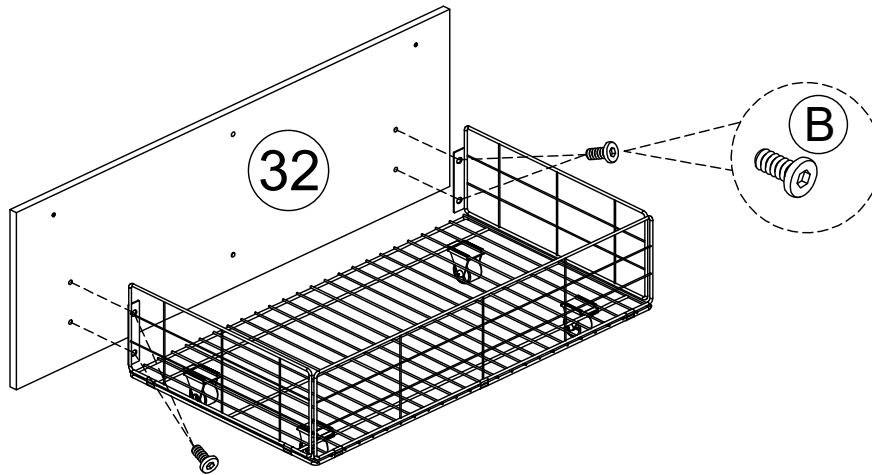



X2

STEP 37

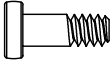
 Please screws in this step need to be tightened

	Ø1/4" x 16mm
(G)	x 2

	Ø1/4" x 11mm
(B)	x 2

	
(S)	x 2

	M4
(AA)	x 1

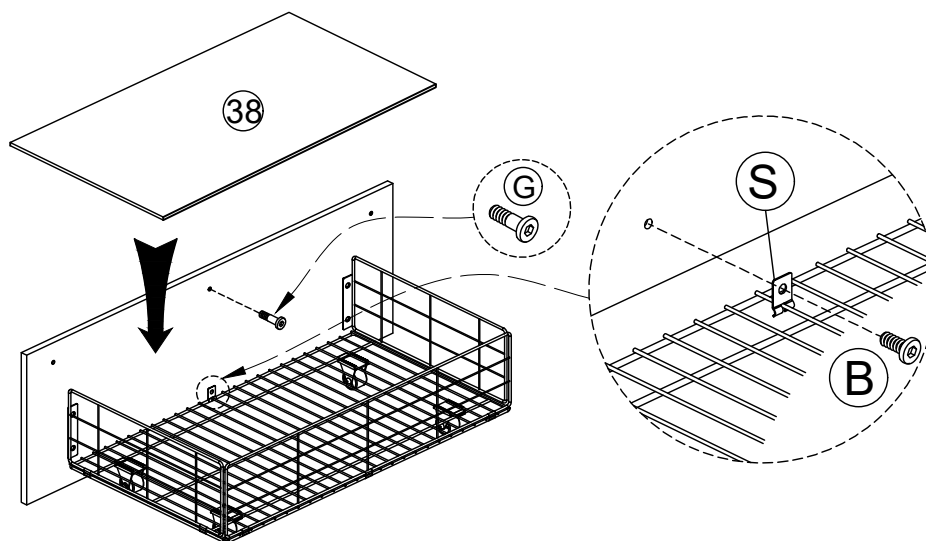

To lock the drawer in your preferred position, first confirm the desired location by referring to STEP 38

X2

STEP 38

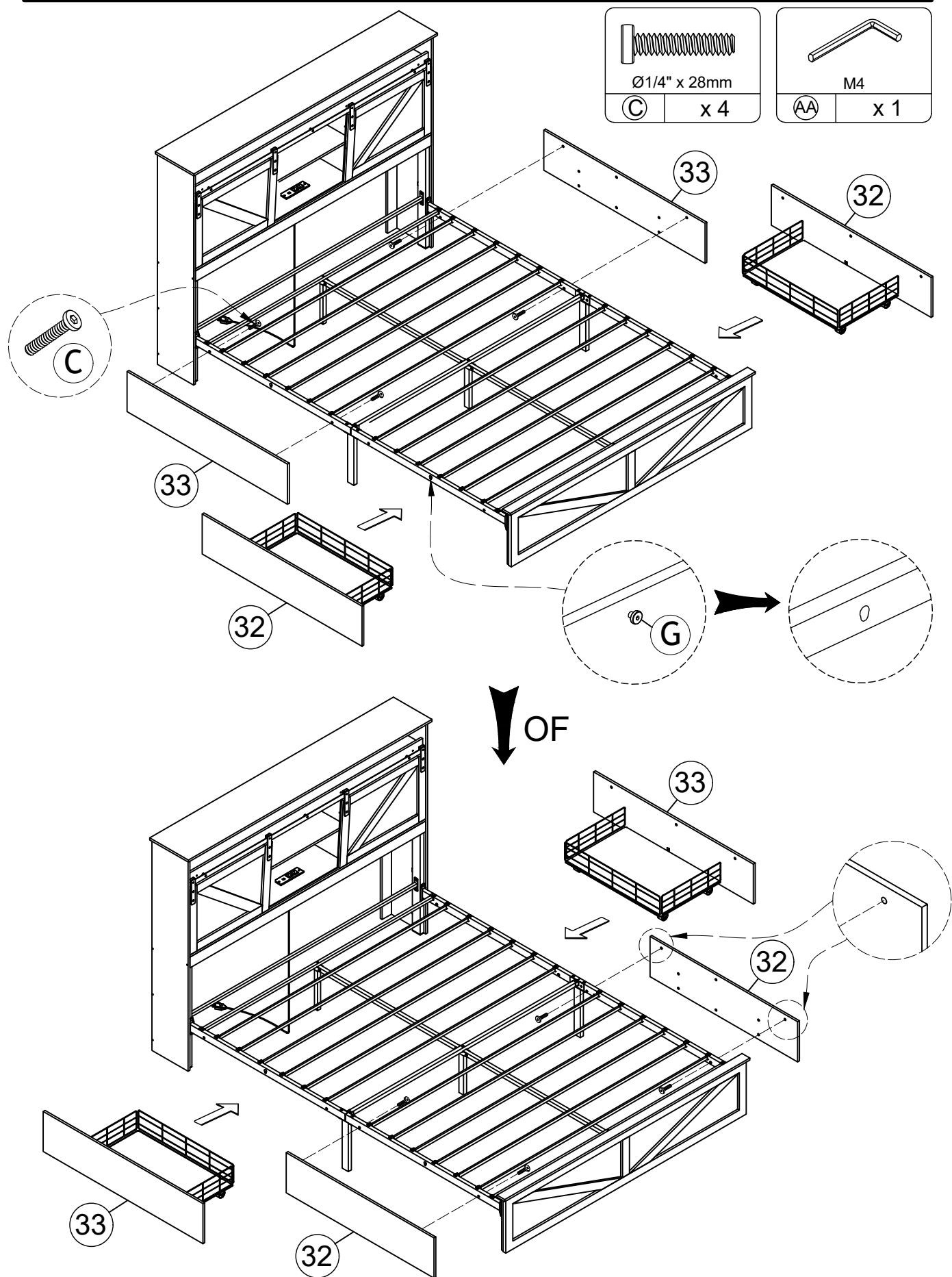

STEP 39

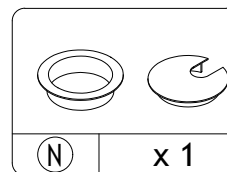
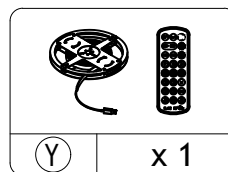
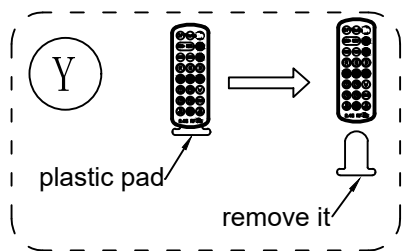

Please pull the plastic block out of the remote control.

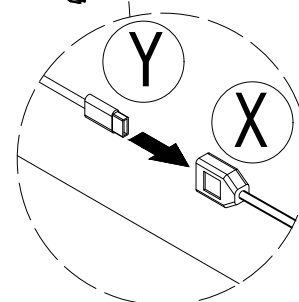
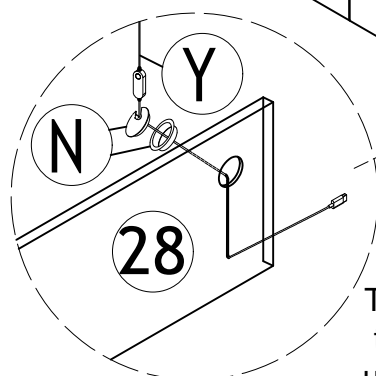
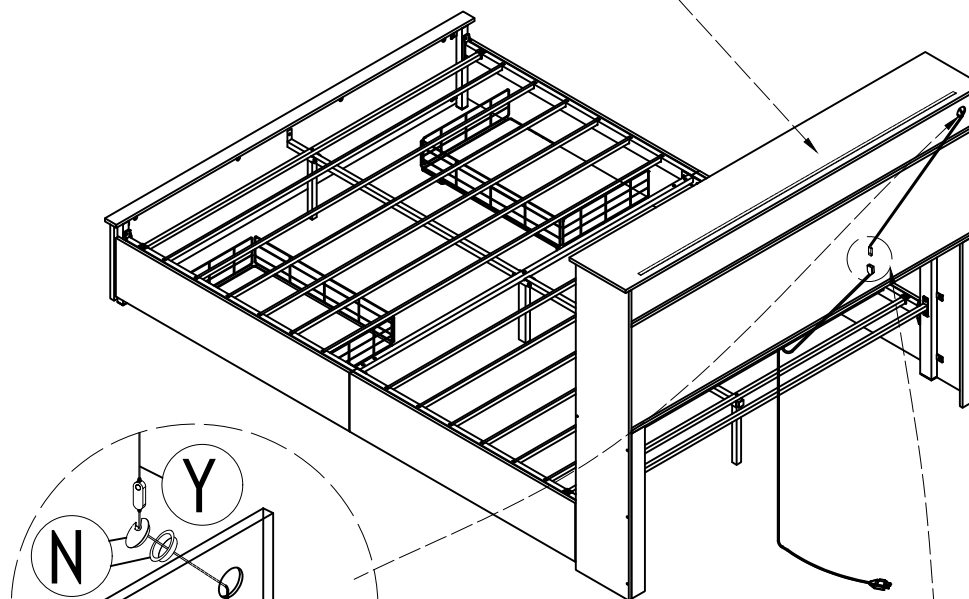
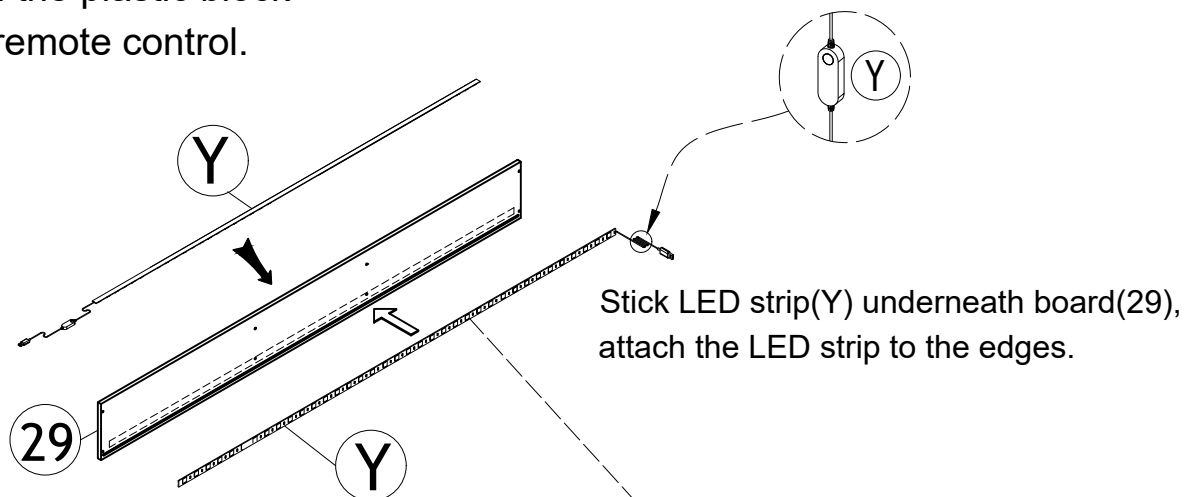

Congratulation:

Congratulations to you on completing the assembly of the product through your own efforts, you have done a great job.

The assembly of this product may have been difficult, but you still had the patience and perseverance to get it done.

Notes:

1. The product is designed for indoor use only and must be assembled and used according to the provided manual. Modifying or altering the product from its original design may result in personal injury or damage to the product.

Product Maintenance:

1. Please place this item on the level solid ground.
2. Avoid long-term exposure to humid environments to prevent mildew.
3. Keep the product away from high temperature environments or fire sources.
4. If accidentally spill water or another liquid on the surface, immediately wipe with a dry towel.
5. Regularly inspect the tightness of screws while using the product. If necessary, re-tighten to ensure structural stability.