

Assembly Instructions

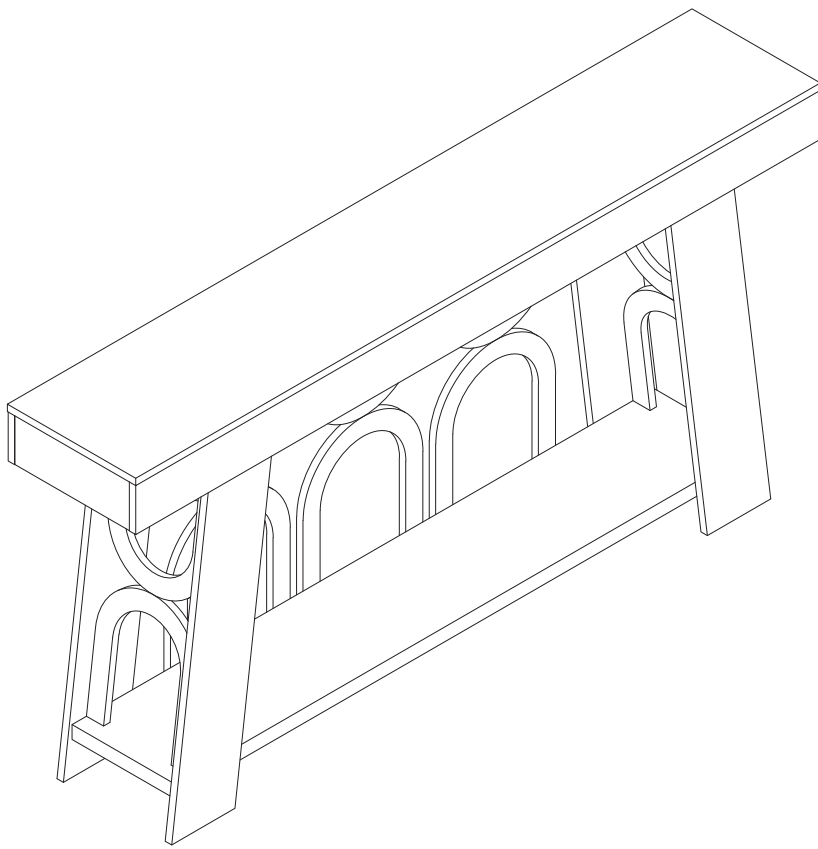

Console Table

Model No.
HOGA-GL0017

Contact Us

We're here to help you.

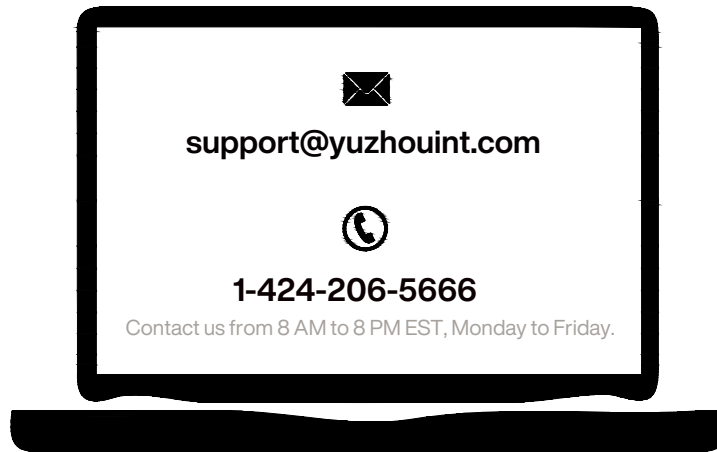

Your satisfaction is our top priority. If you encounter any issues with this product, such as missing or damaged parts, we're here to help. Please retain the original packaging and take photos of the packaging and the product, then contact us as soon as possible.

Warm Tips

1. Carefully read these instructions and keep them for future reference.
2. Check the parts list and confirm everything's there before starting assembly.
3. When assembling, put all parts on a soft, smooth surface like a carpet to avoid scratches.
4. Don't fully tighten screws until all parts are confirmed in place to avoid misalignment.

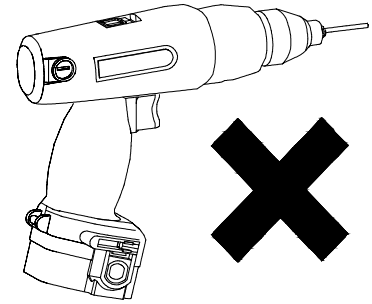
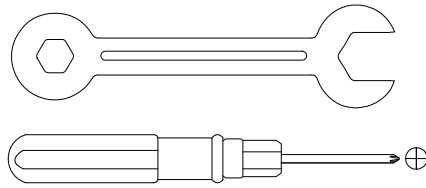
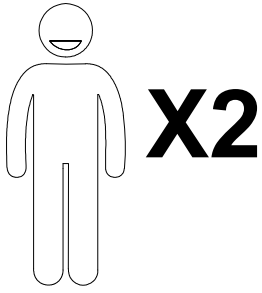

We recommend using hand tools for assembly.

If an electric screwdriver is used, reduce power and torque to avoid damage to the product.

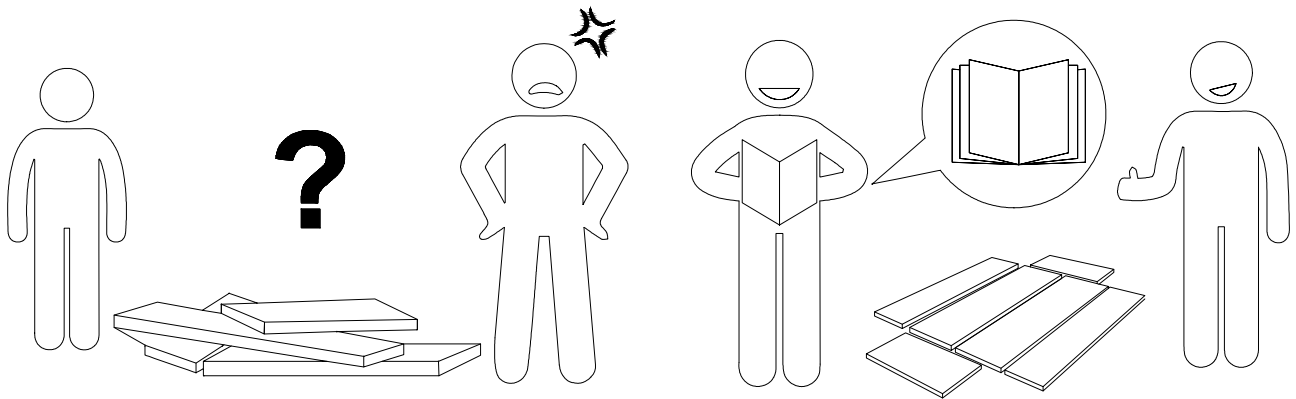

Install the Anti-Tip Straps

Using the anti-tip straps can reduce the risk of tipping over, but can not eliminate it.

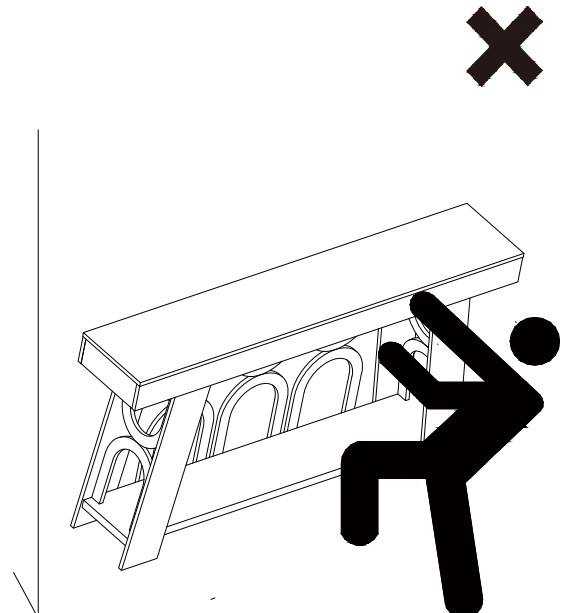
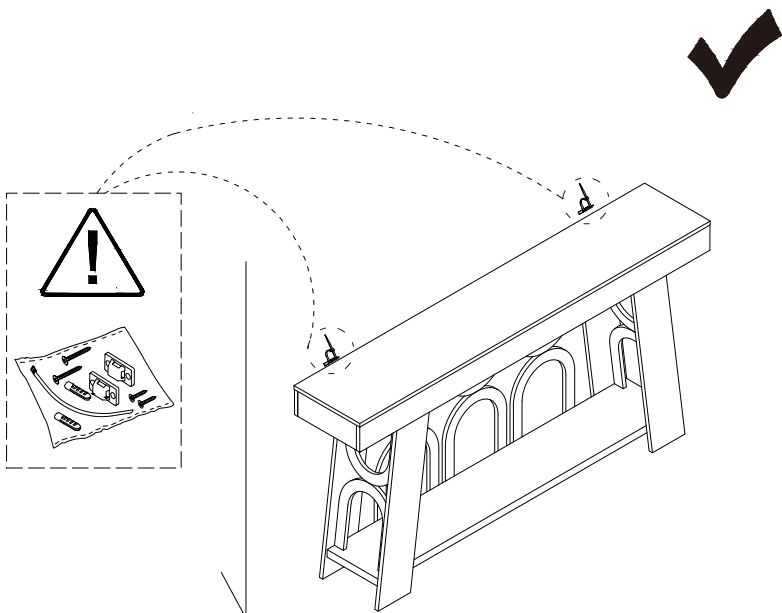

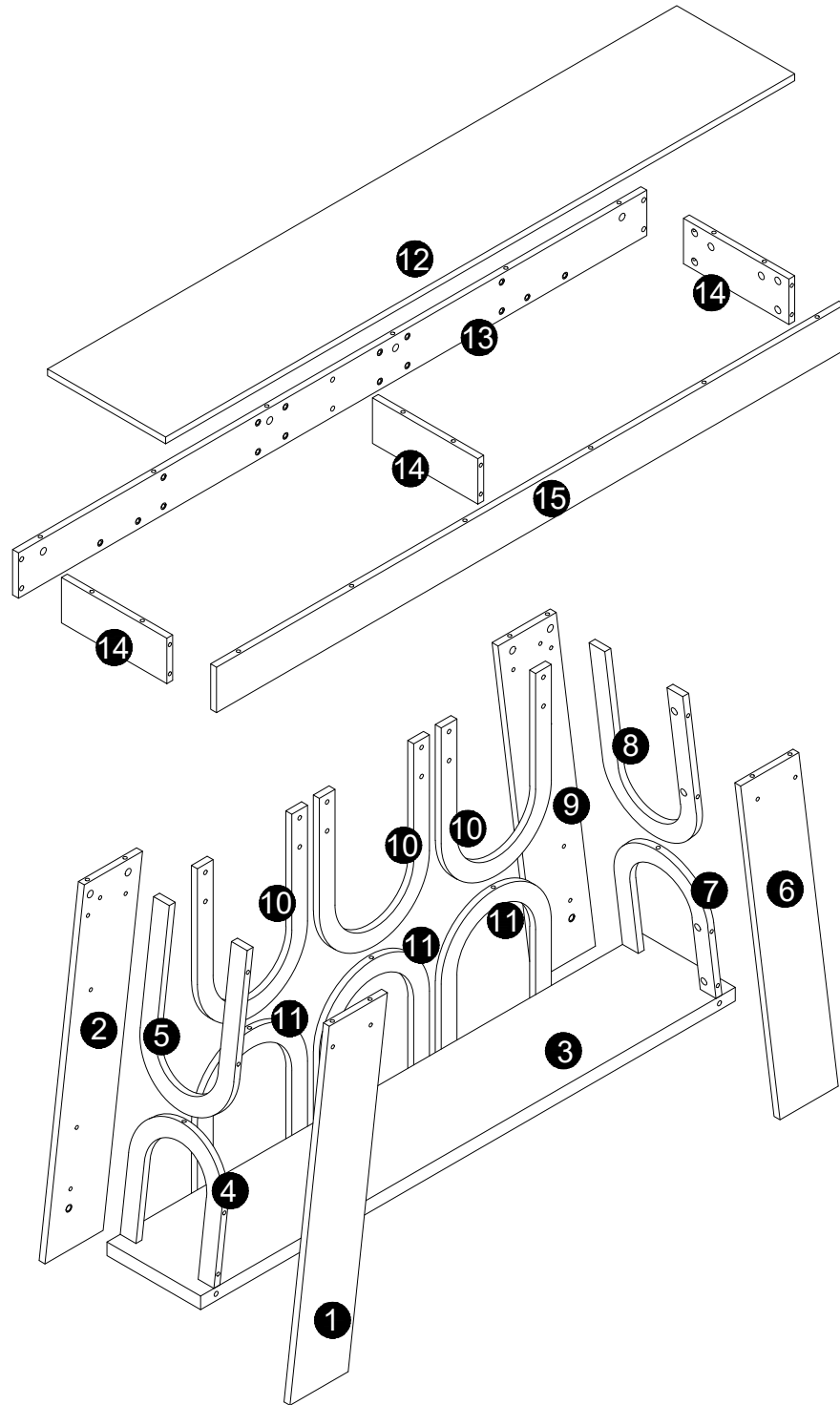



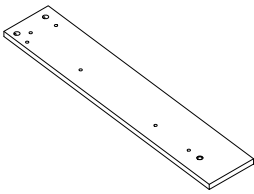
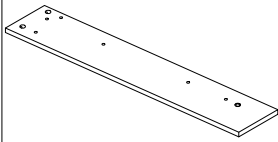
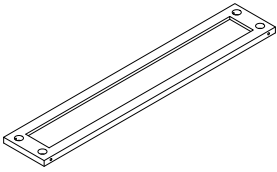
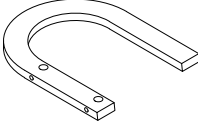
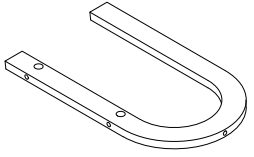
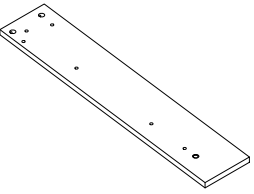
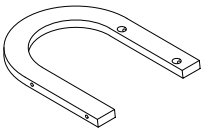
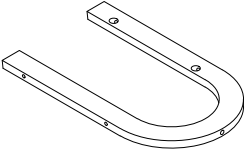
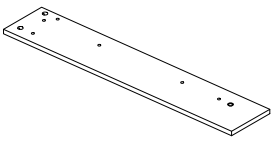
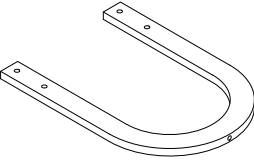
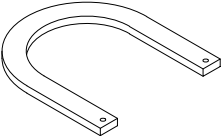
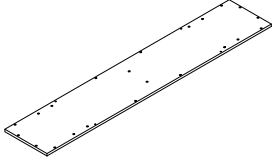
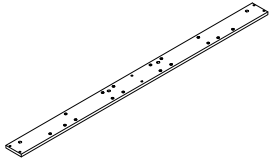
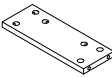
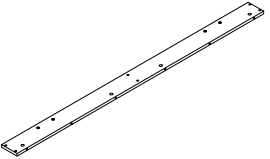

⚠ Caution

Make sure all parts are included. Most board parts are labeled or stamped on the raw edge. Contact us for a free replacement if you encounter any damaged or missing parts.

Parts List

1  1pc	2  1pc	3  1pc	4  1pc	5  1pc
6  1pc	7  1pc	8  1pc	9  1pc	10  3 pcs
11  3 pcs	12  1pc	13  1pc	14  3 pcs	15  1pc

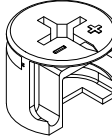
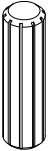
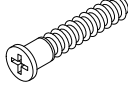
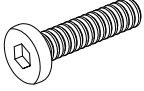
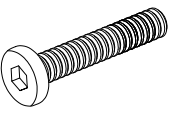
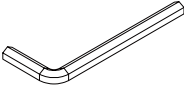
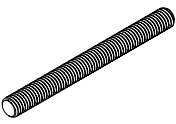
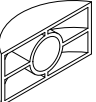
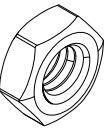
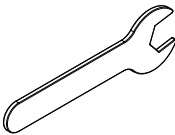
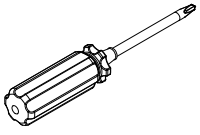
Hardware List

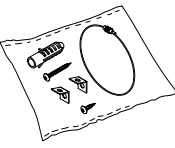
A	B	C	D	E	F
 <p>M6x35mm</p>	 <p>Ø15x12mm</p>	 <p>Ø8x30mm</p>	 <p>Ø7x38mm</p>	 <p>M6x25mm</p>	 <p>M6x30mm</p>
42 pcs	42 pcs	9 pcs	8 pcs	20 pcs	6 pcs
G	H	I	J	K	L
 <p>4 mm</p>	 <p>Ø8x65mm</p>		 <p>Ø8mm</p>		 <p>Screwdriver</p>
1pc	4 pcs	4 pcs	4 pcs	1pc	1pc
M	N				
					
8 pcs	2 pcs				

Installation of Cams and Pins

Step 1-2: Align the plastic part with the mounting hole and press it in. If you can't press it in, loosen the screw counter clockwise or completely remove the screw from the plastic part and try again.
Step 3-4: After pressing the plastic part into place, use a screwdriver to tighten the screw clockwise.

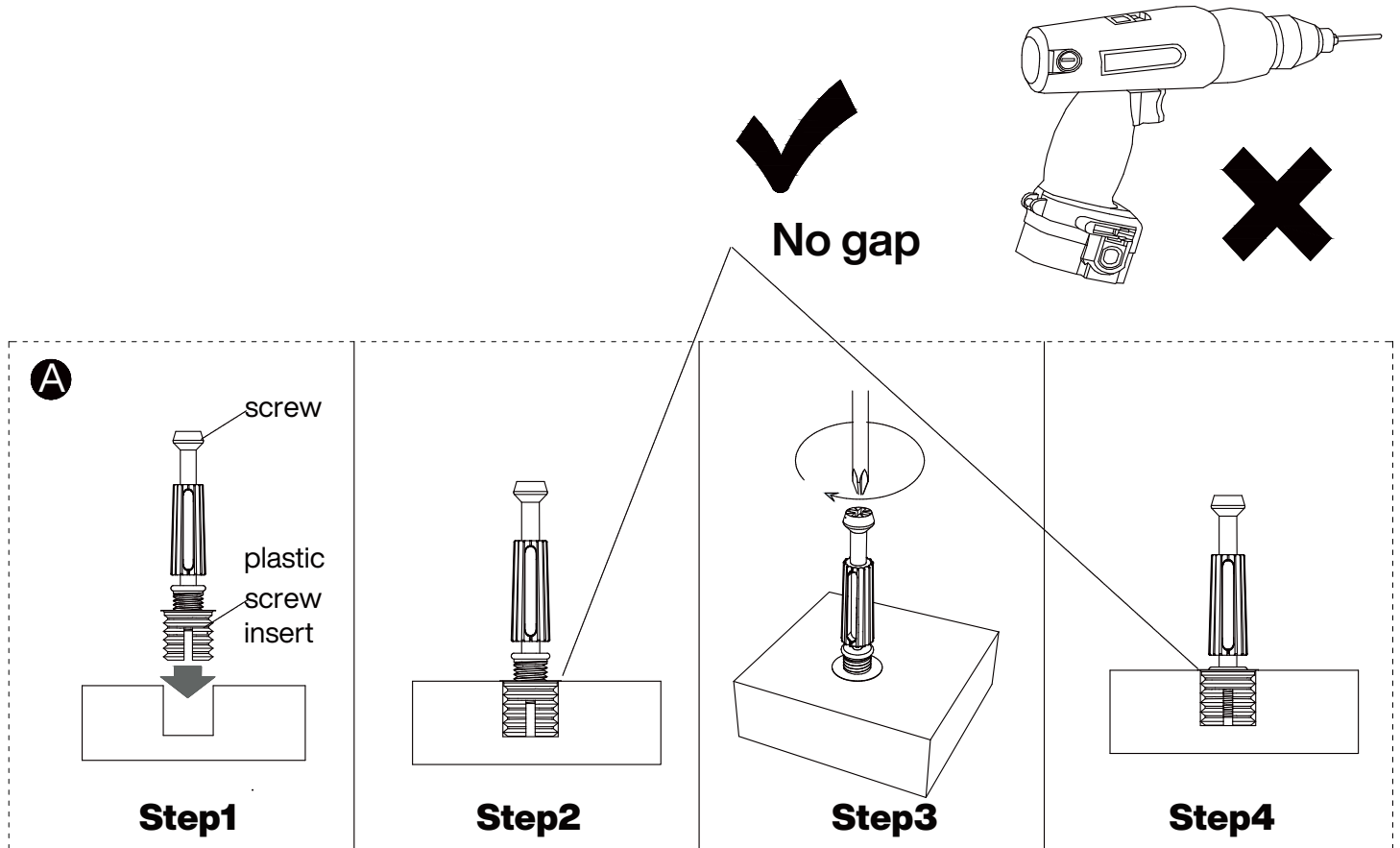

Screw the pin into the hole. Set the cams correctly by aligning the head of the cams with the lock pins. Lock the cam by turning the cam head with a screwdriver until it is tightened. Please do not use an electric screwdriver to assemble the unit.

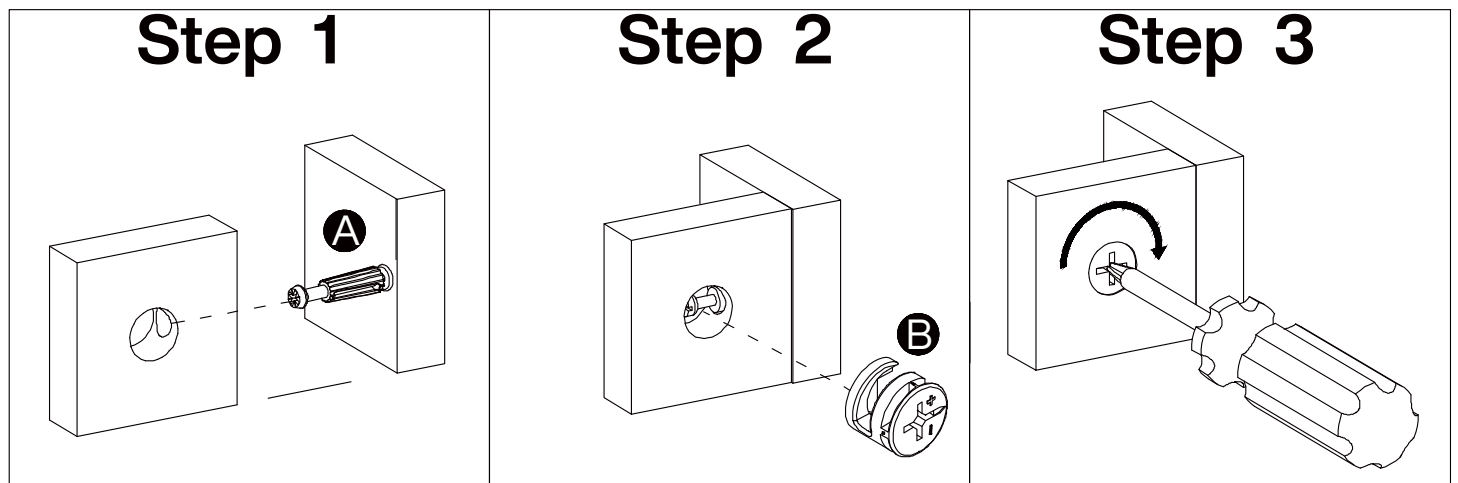

1

A

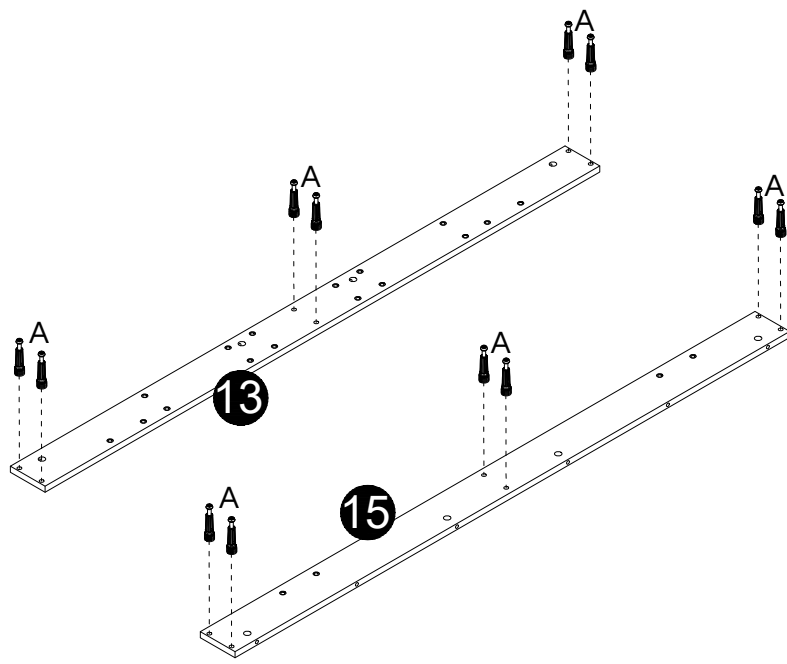
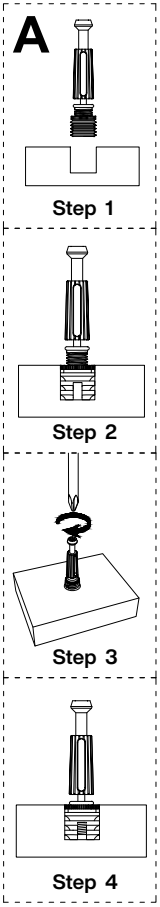
M6x35mm 12 pcs

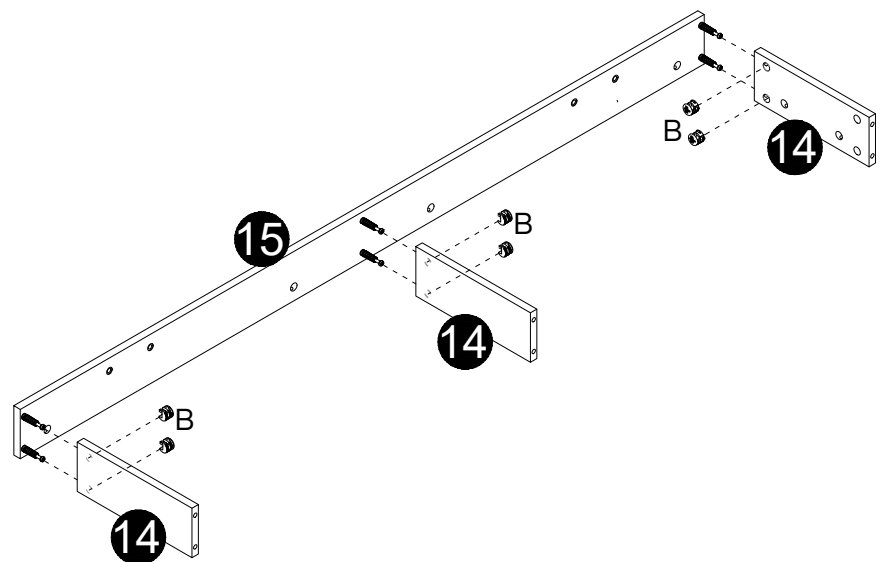
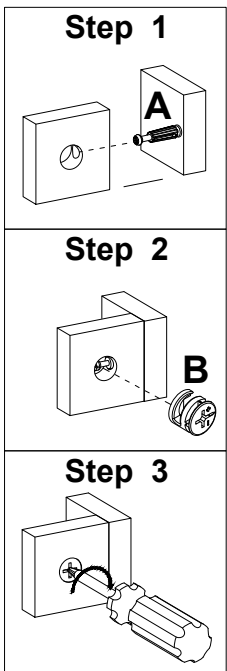

2

B

Ø15x12mm 6 pcs



3

B

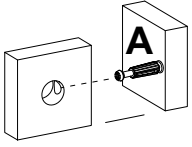
Ø15x12mm
6 pcs

Step 1

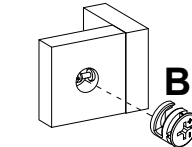

Step 2



Step 3

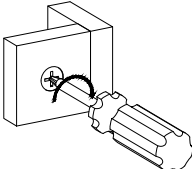
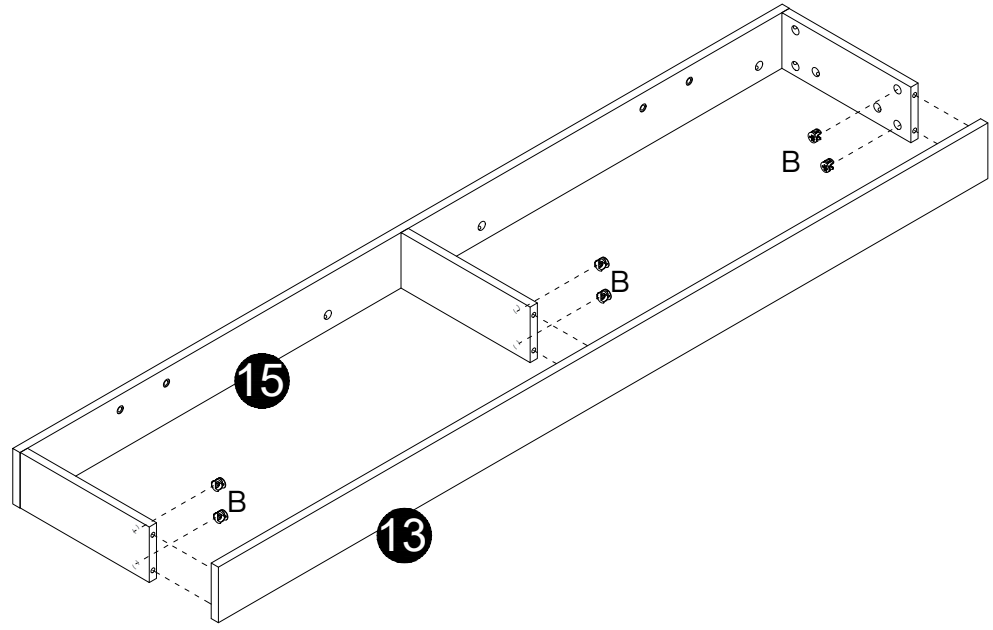

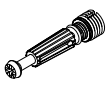
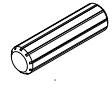

4

A	C
	
M6x35mm	Ø8x30mm
22 pcs	4 pcs

A

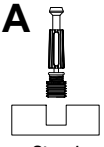
Step 1



Step 2

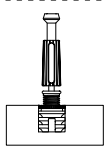

Step 3

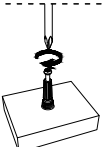

Step 4

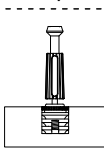
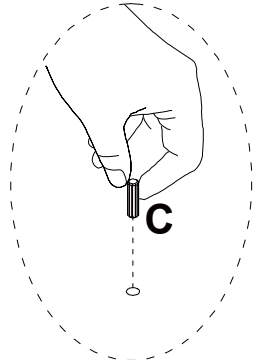
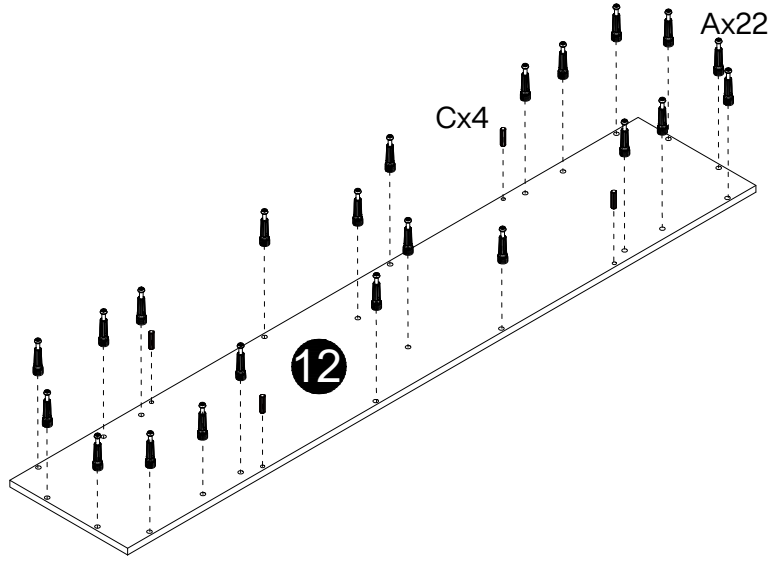
5

B

Ø15x12mm
14 pcs

Step 1

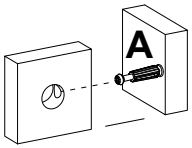

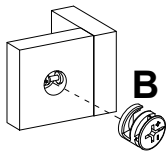

Step 2

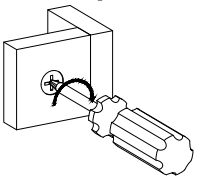
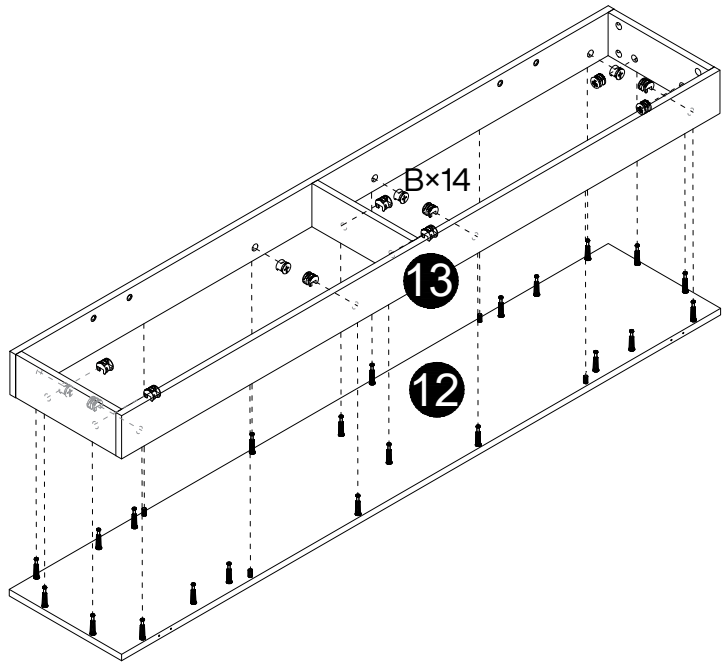

Step 3

6

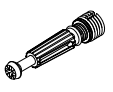
A	H
	
M6x35mm	Ø8x65mm
8 pcs	2 pcs

Step 1

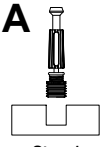

Step 2

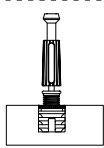

Step 3

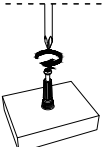

Step 4

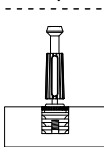
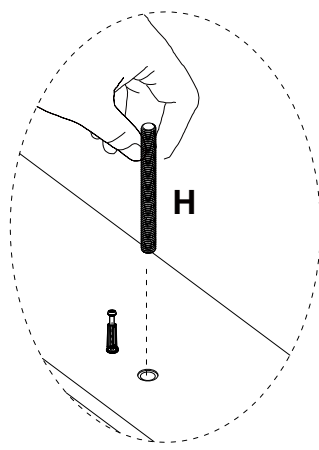
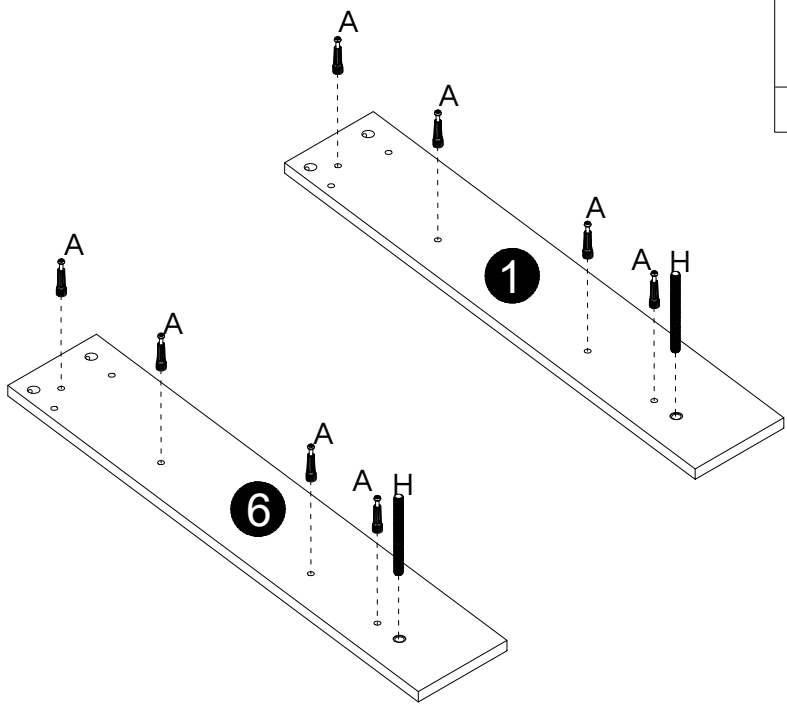



7

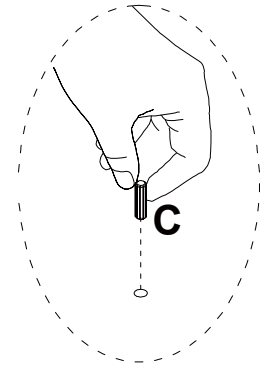
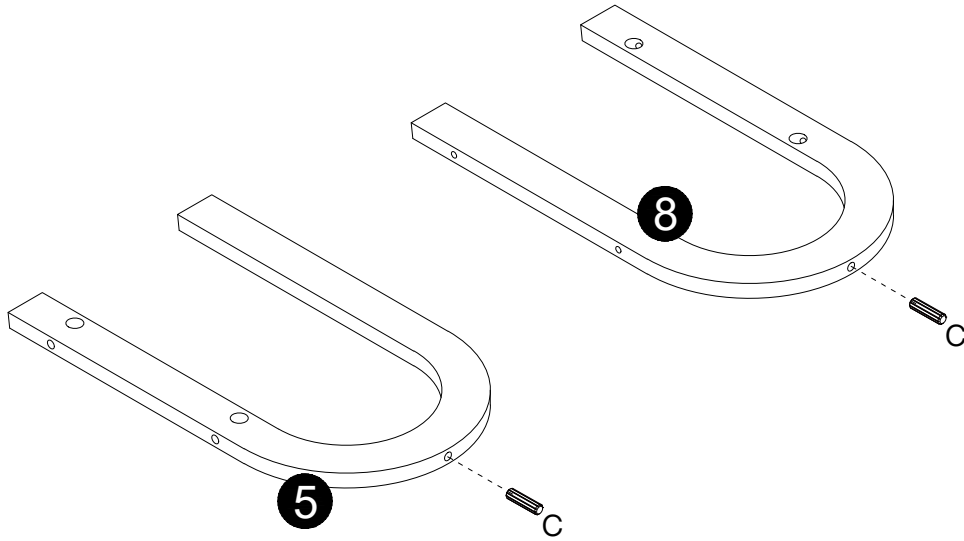

C

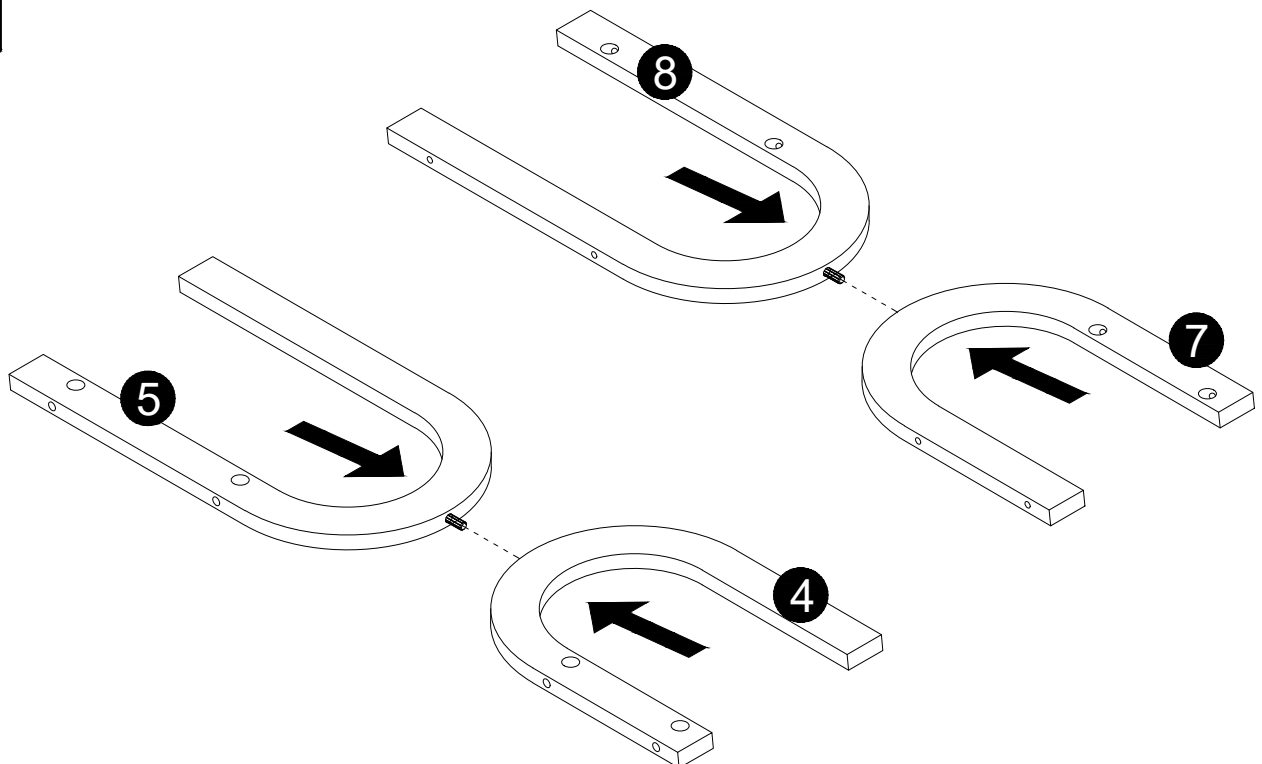
Ø8x30mm
2 pcs



8



9

I	J
	
2 pcs	Ø8mm 2 pcs

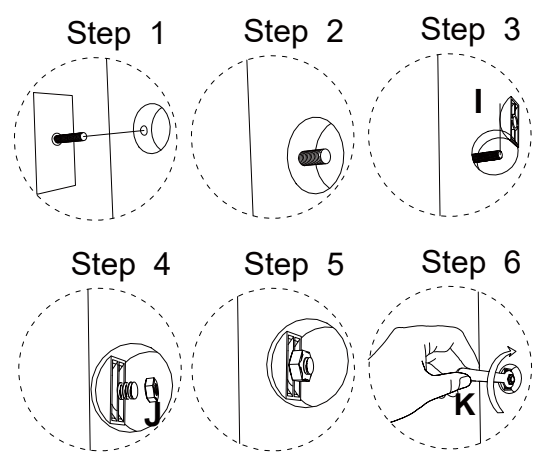
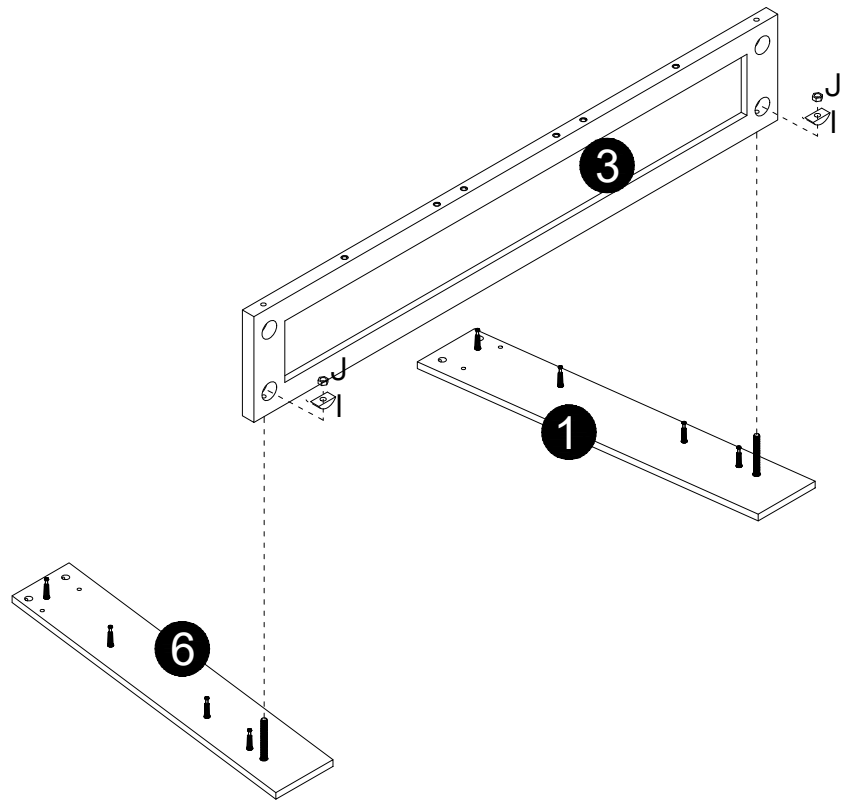

10

B

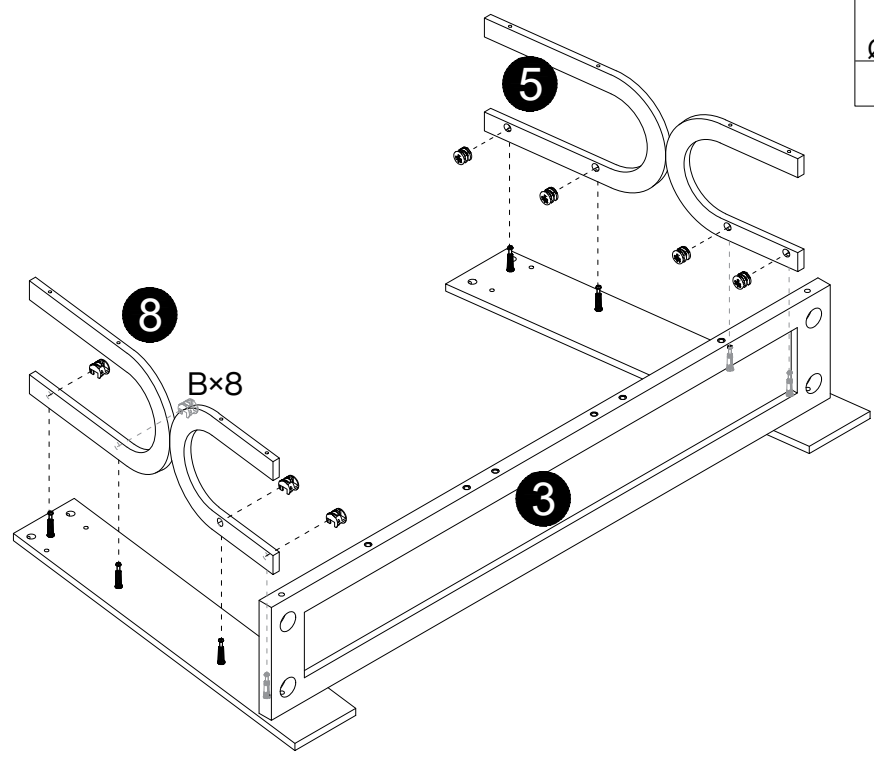
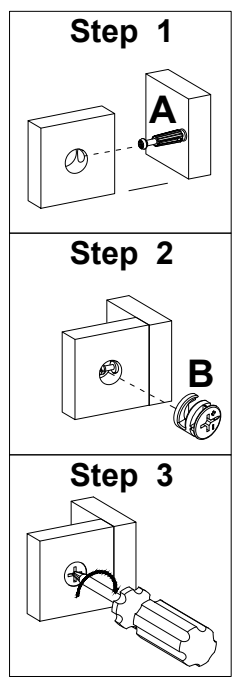
Ø15x12mm 8 pcs



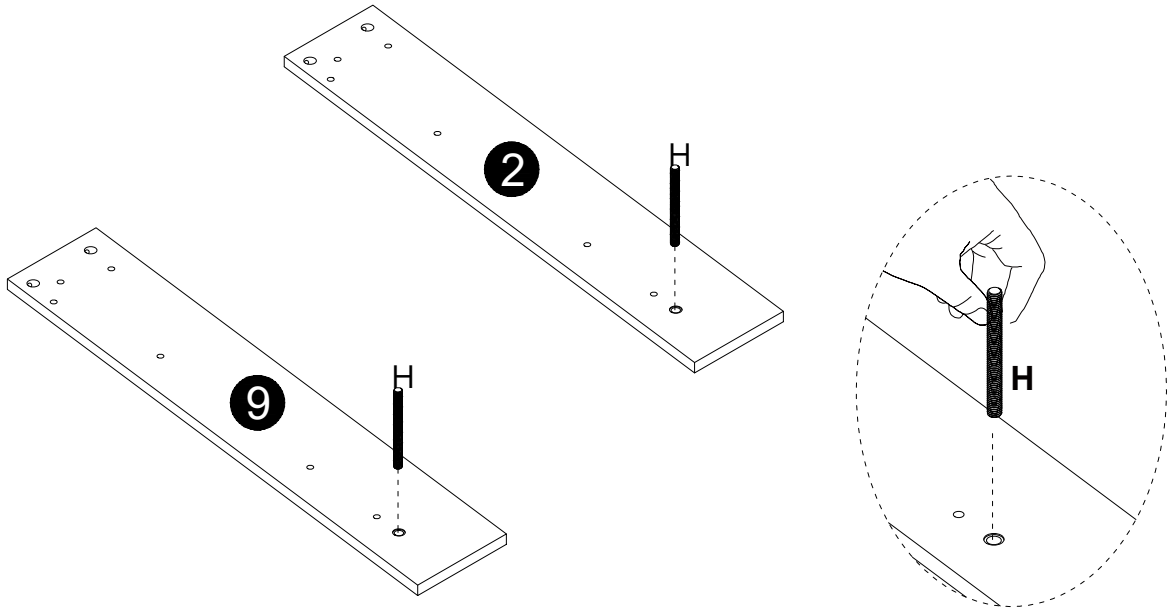

11

H

Ø8x65mm
2 pcs

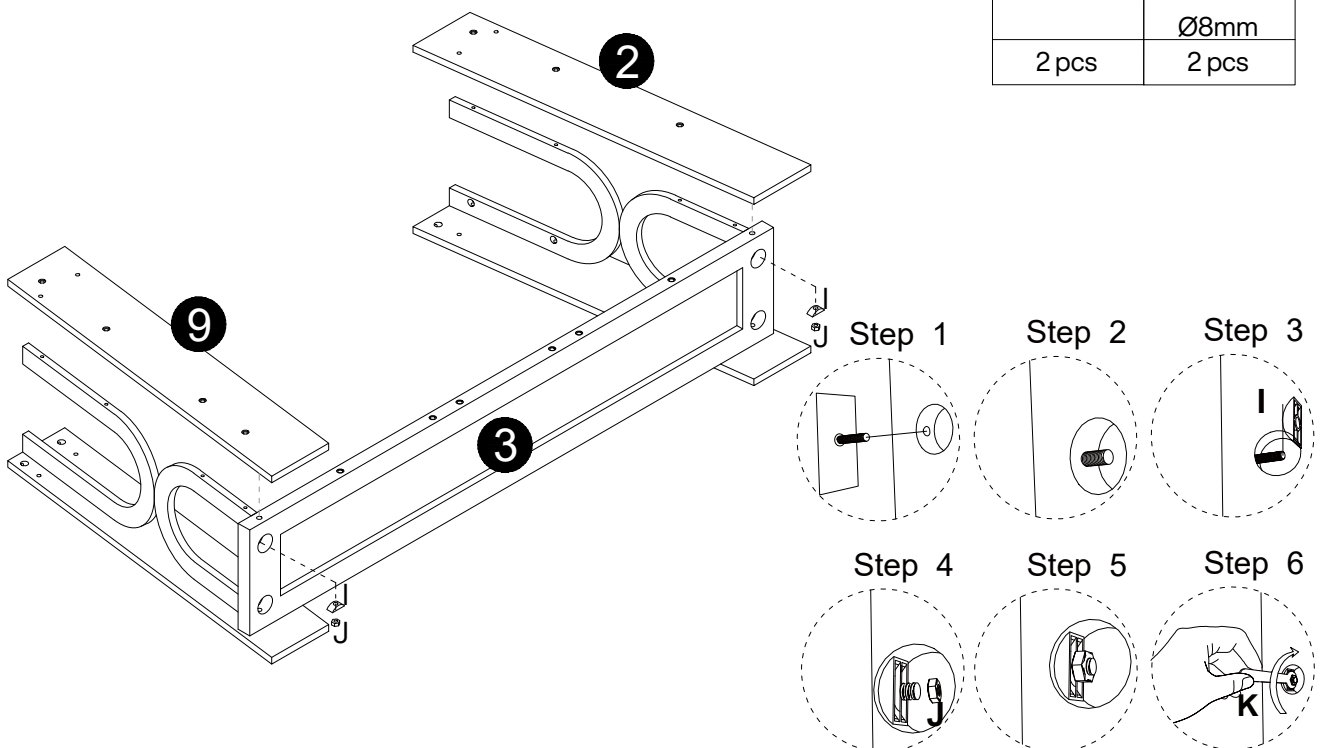

12

I	J
	
2 pcs	Ø8mm
	2 pcs



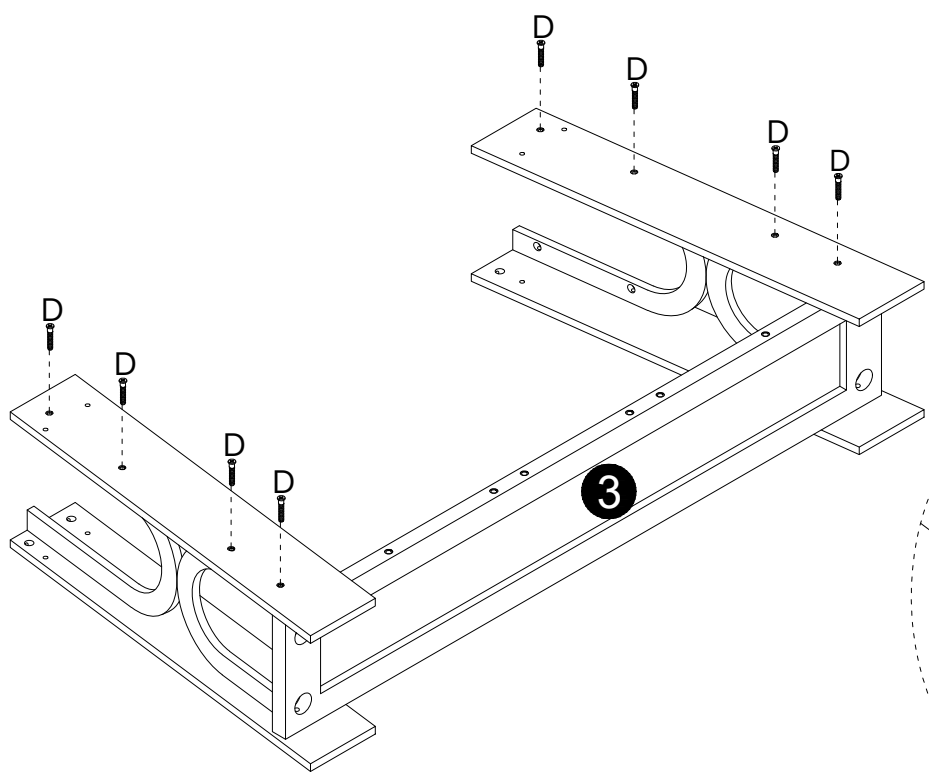

13

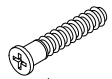

D

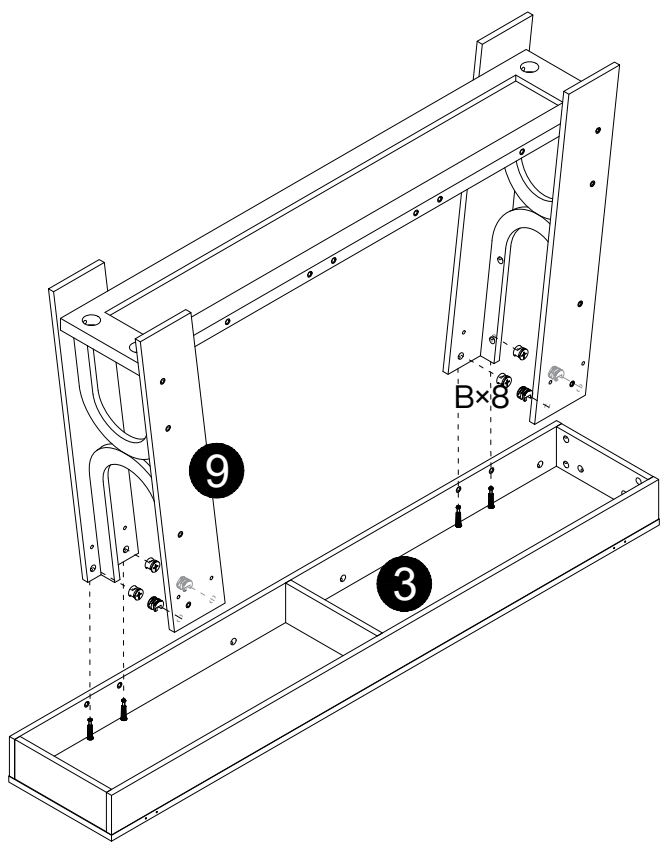
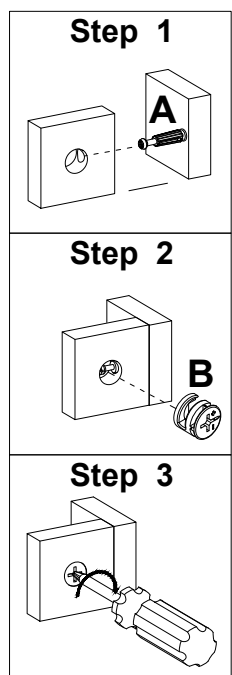
Ø7x38mm
8 pcs

14

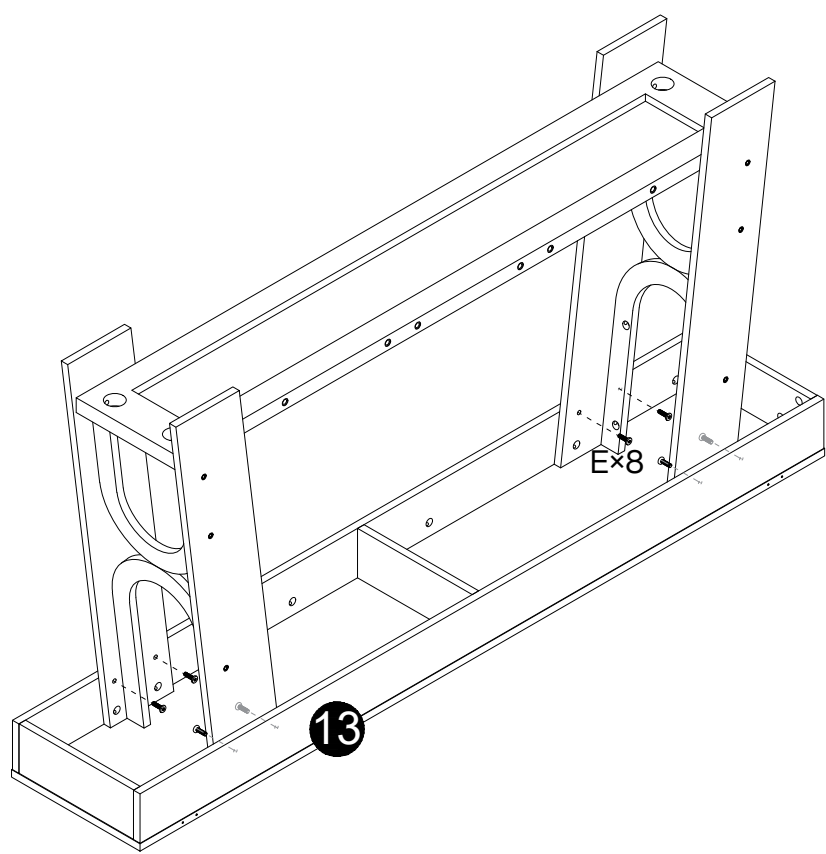

B

Ø15x12mm
8 pcs

15

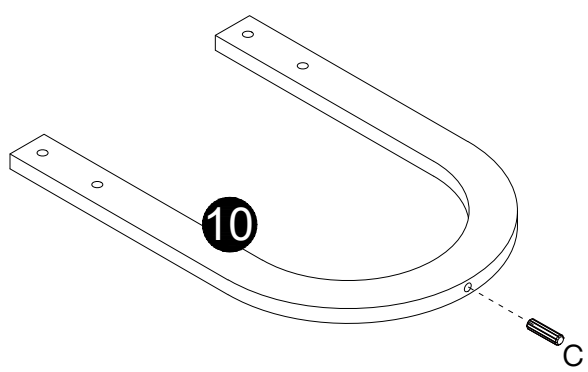

E

M6x25mm
8 pcs

16

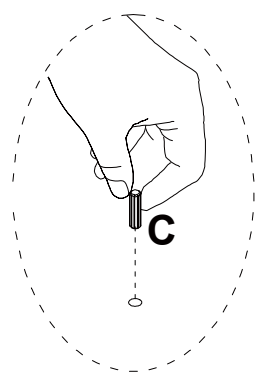

X3

C

Ø8x30mm
3 pcs

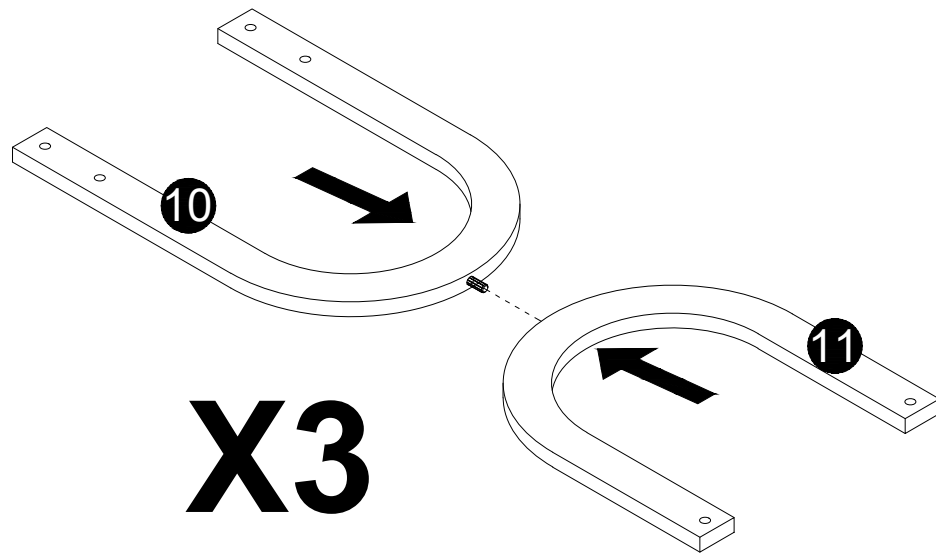

17

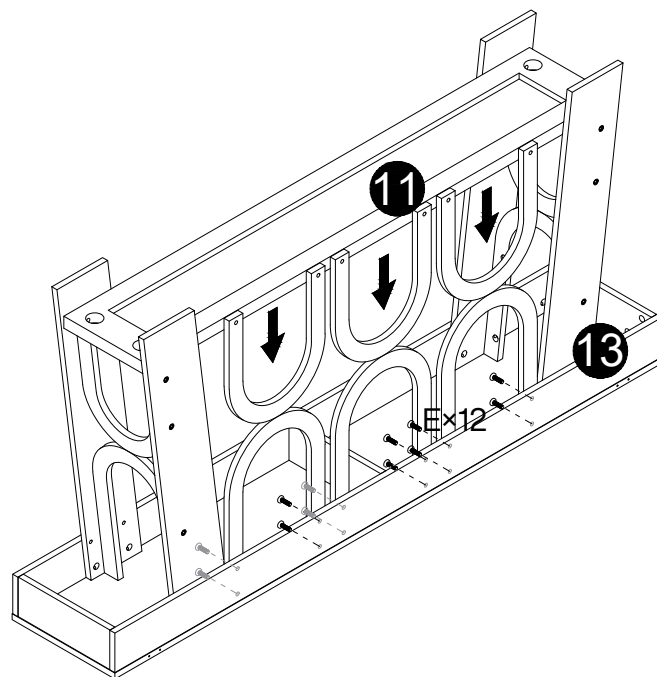

18

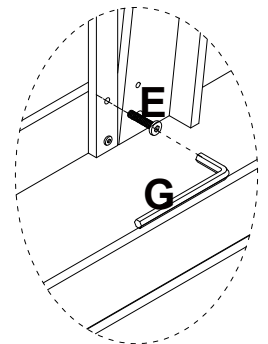

E

M6x25mm
12 pcs

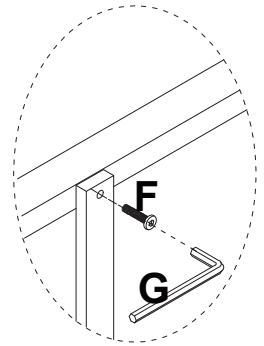
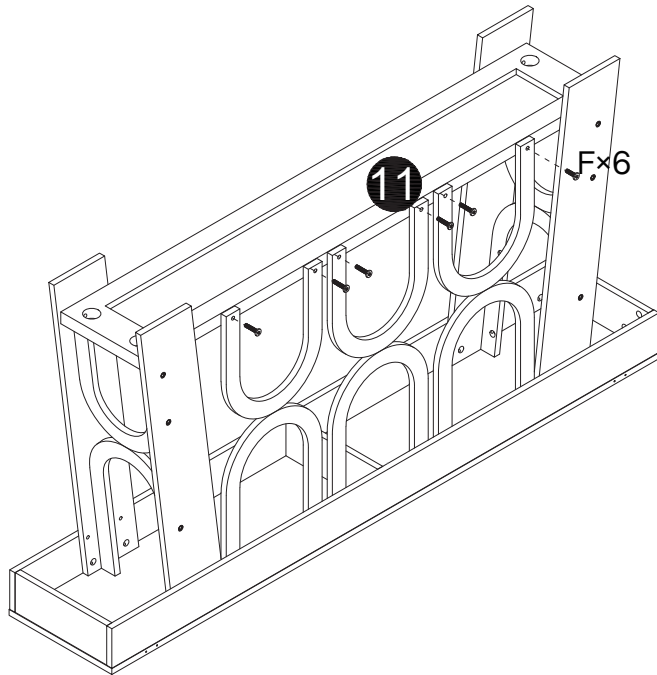

19

F

M6x30mm
6 pcs

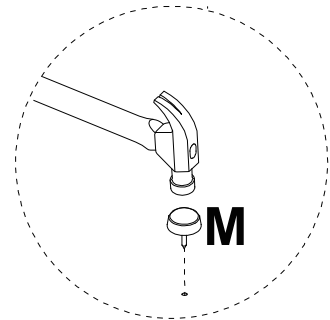
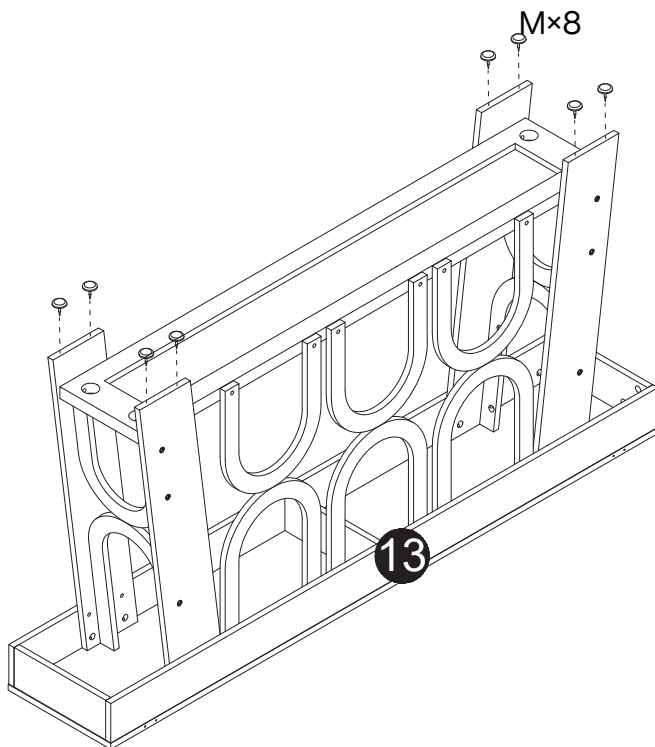

20

M

8 pcs

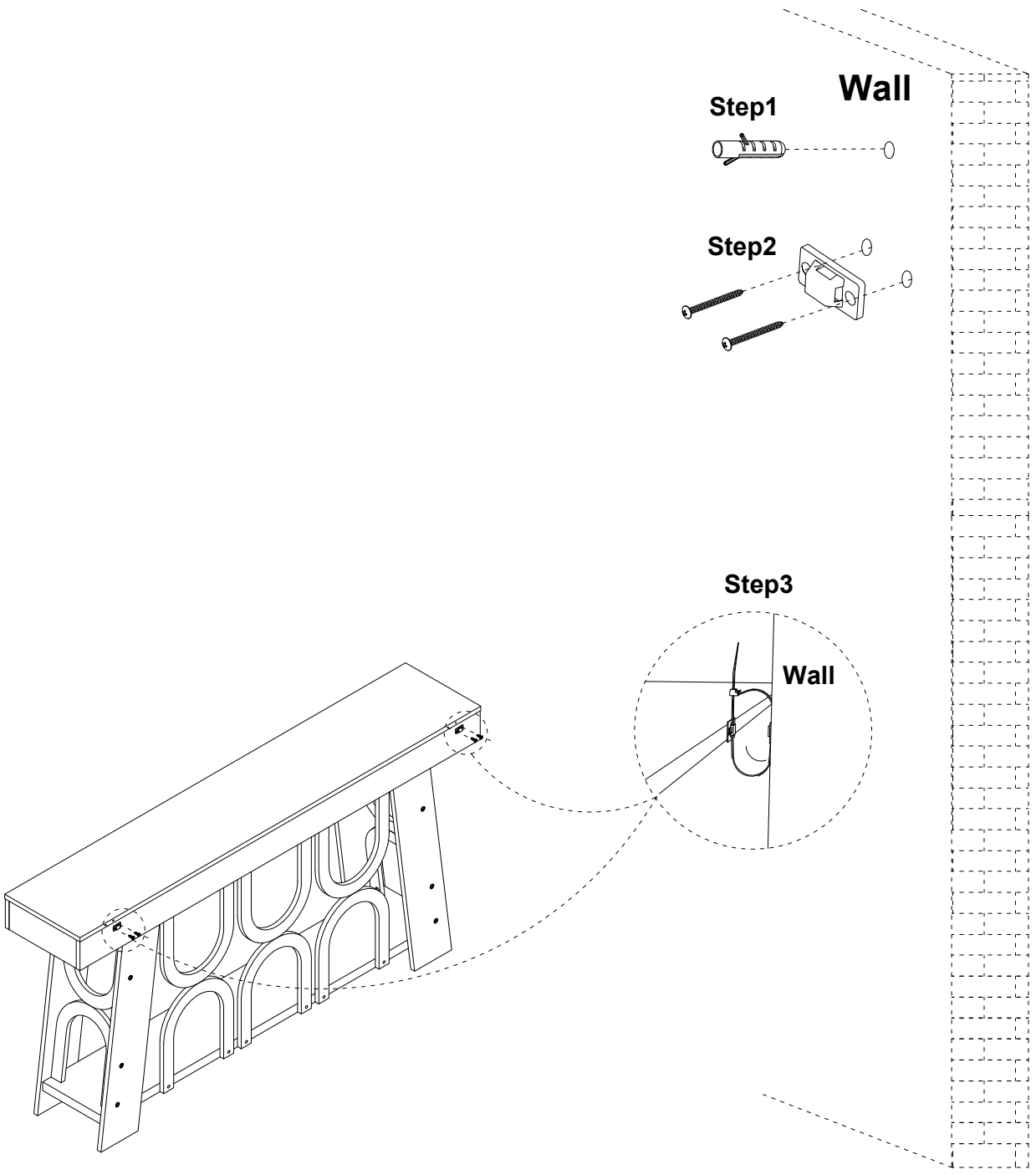

⚠ Caution! Tap lightly

N

2 pcs



Thank you for your support!

