

Attention:  
Two people are required for assembly and lifting unit.

# ASSEMBLY INSTRUCTION

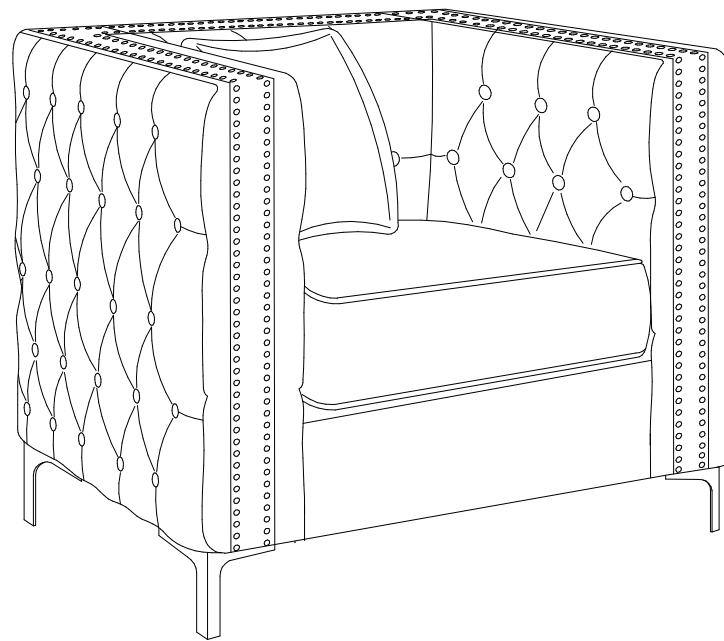

# ASSEMBLY PART

1.

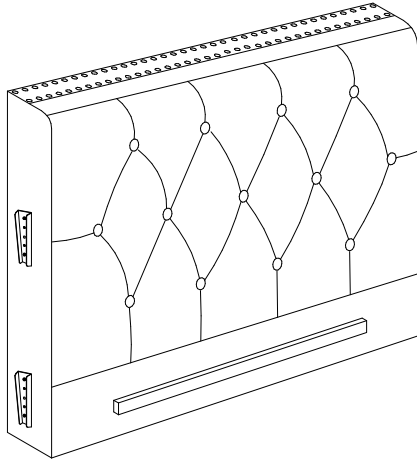

BACK REST (1PC)

2.

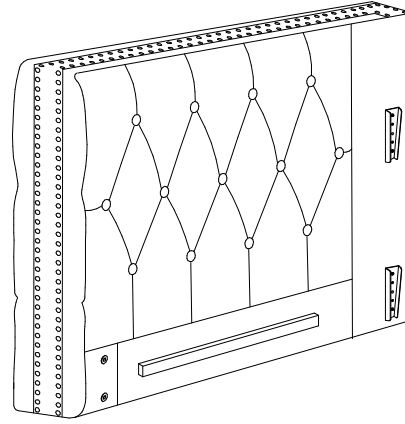

LEFT ARM (L) (1PC)

3.

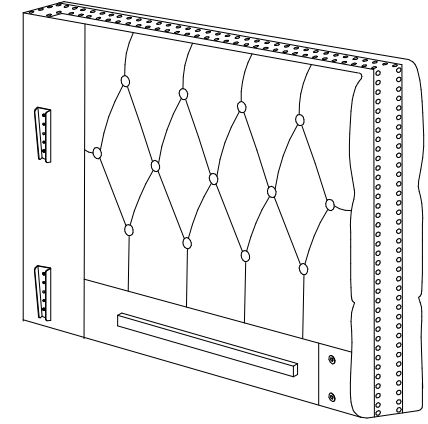

RIGHT ARM (R) (1PC)

4.

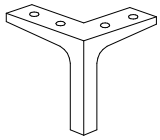

LEG (4PCS)

5.

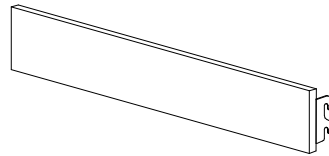

FRONT RAIL (1PC)

6.

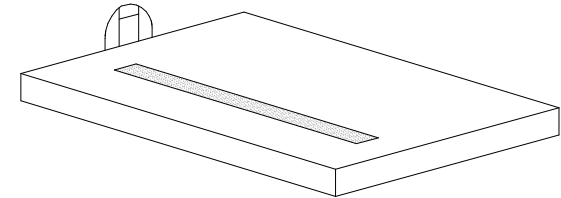

SEAT PANEL (1PC)

7.

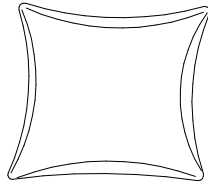

PILLOW (1PC)

8.

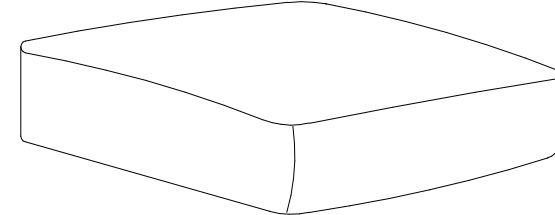

SEAT CUSHION (1PC)

# HARDWARE LIST



**A**

**1PC**

Allen Key M4

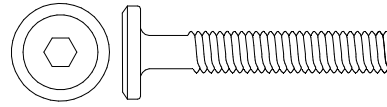

**B**

**8PCS**

JCBC Bolt M6 X 30mm

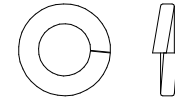

**C**

**8PCS**

Spring Washer M6

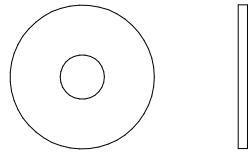

**D**

**8PCS**

Flat Washer M6

**1 : 1**



# ASSEMBLY INSTRUCTION

## STEP 1.

For this step remove all the part and hardware.

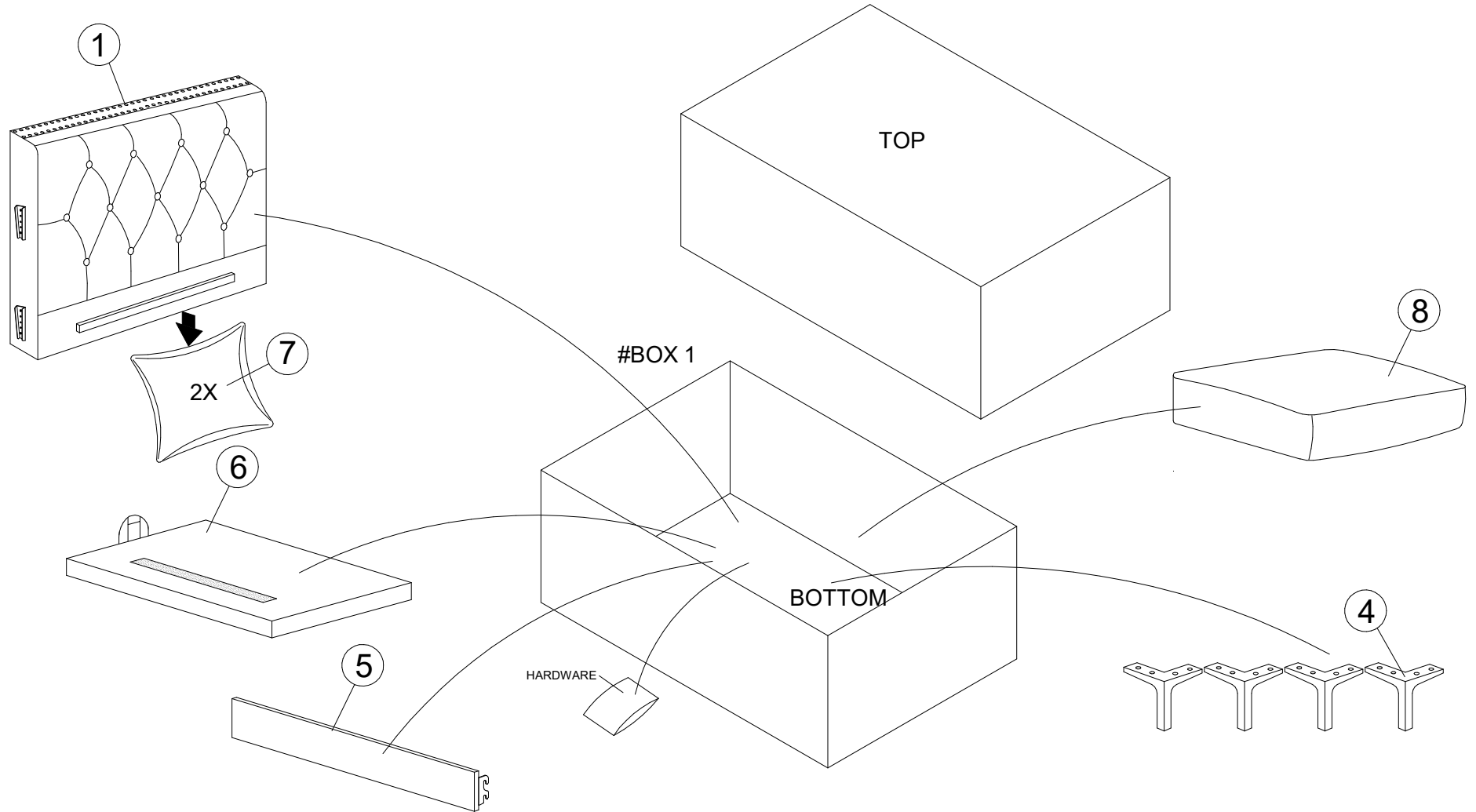

# ASSEMBLY INSTRUCTION

## STEP 2.

For this step remove all the part.

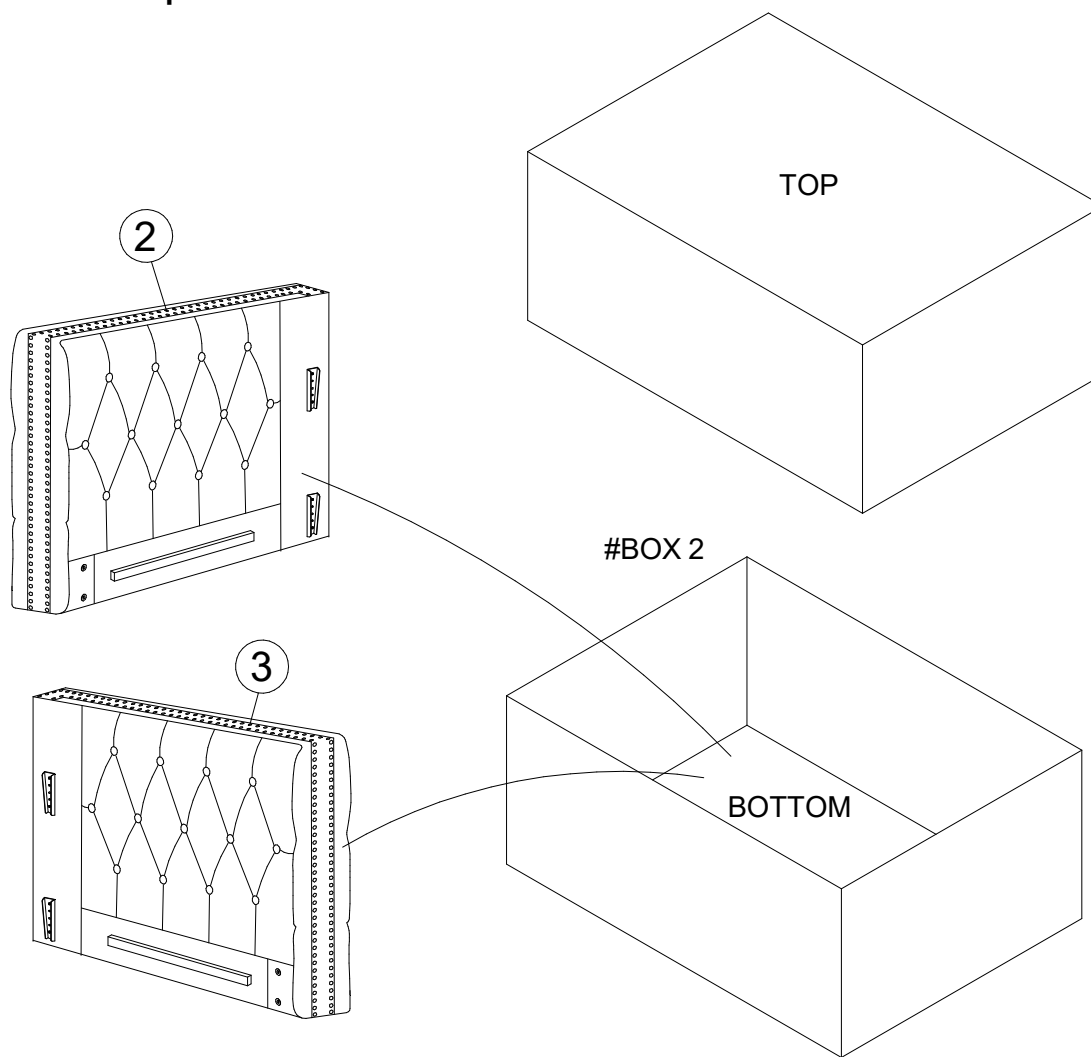

# ASSEMBLY INSTRUCTION

## STEP 3.

Attach Leg (4) (4pcs) to the Left Arm (L) (2) and Right Arm (R) (3). Legs are to be attached using JCBC Bolt M6 x 30mm (B) (8pcs) Spring Washer M6 (C) (8pcs), Flat Washer M6 (D) (8pcs) using Allen Key (A). Make sure bolt are fully tightened and secure.

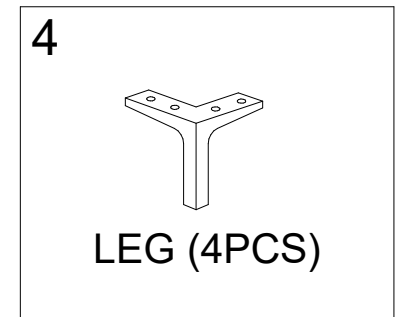
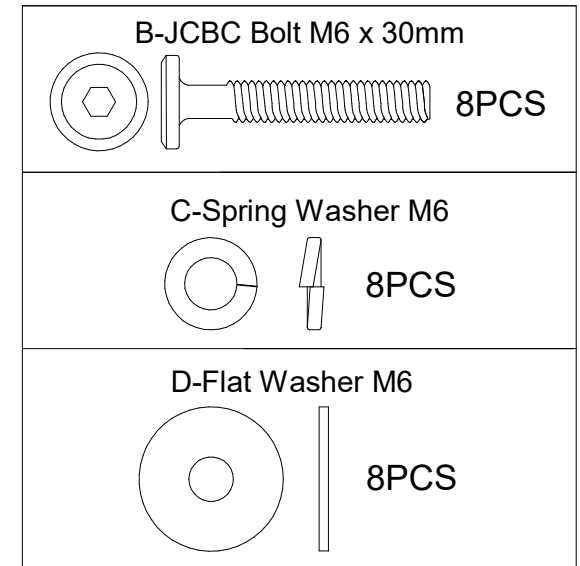
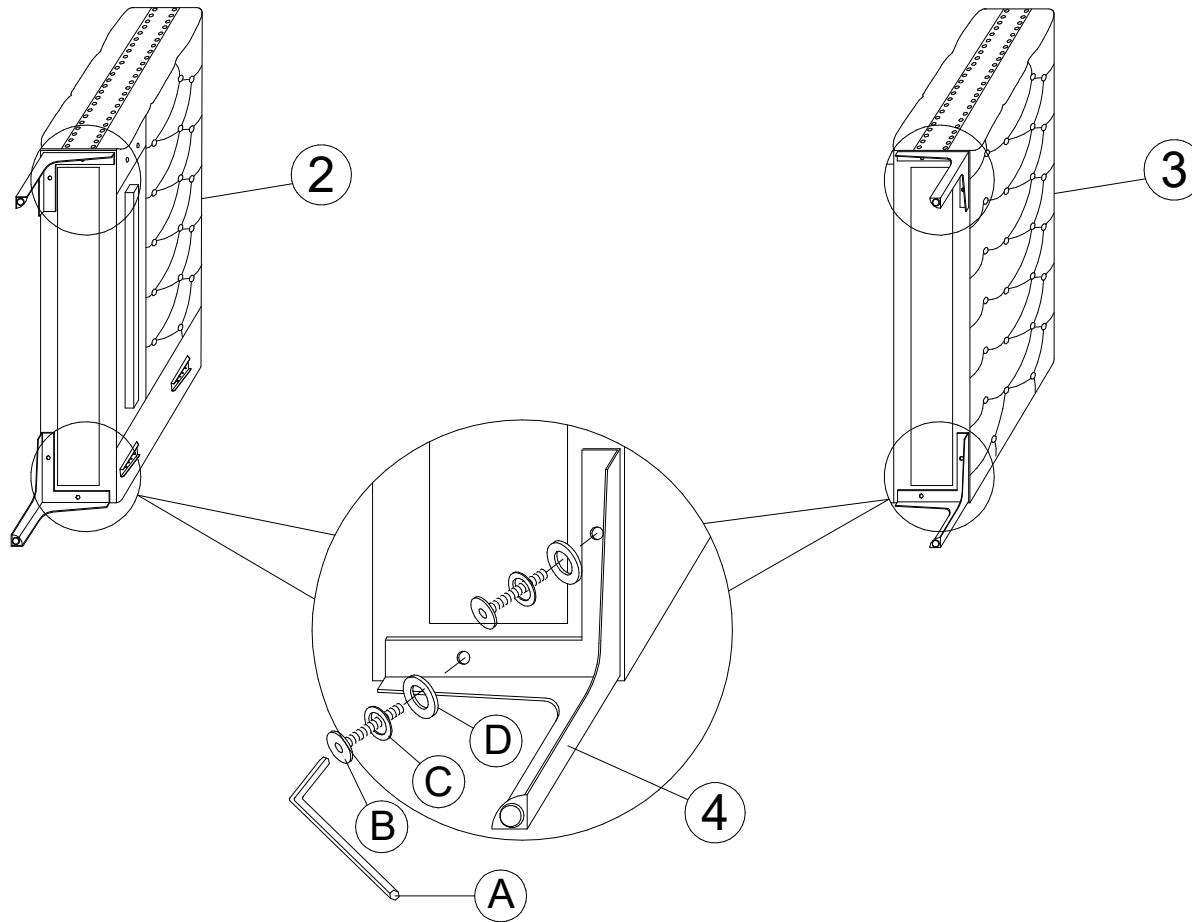

# ASSEMBLY INSTRUCTION

## STEP 4.

Hook on the Back Rest (1) into Left Arm (2) and Right Arm (3) securely.

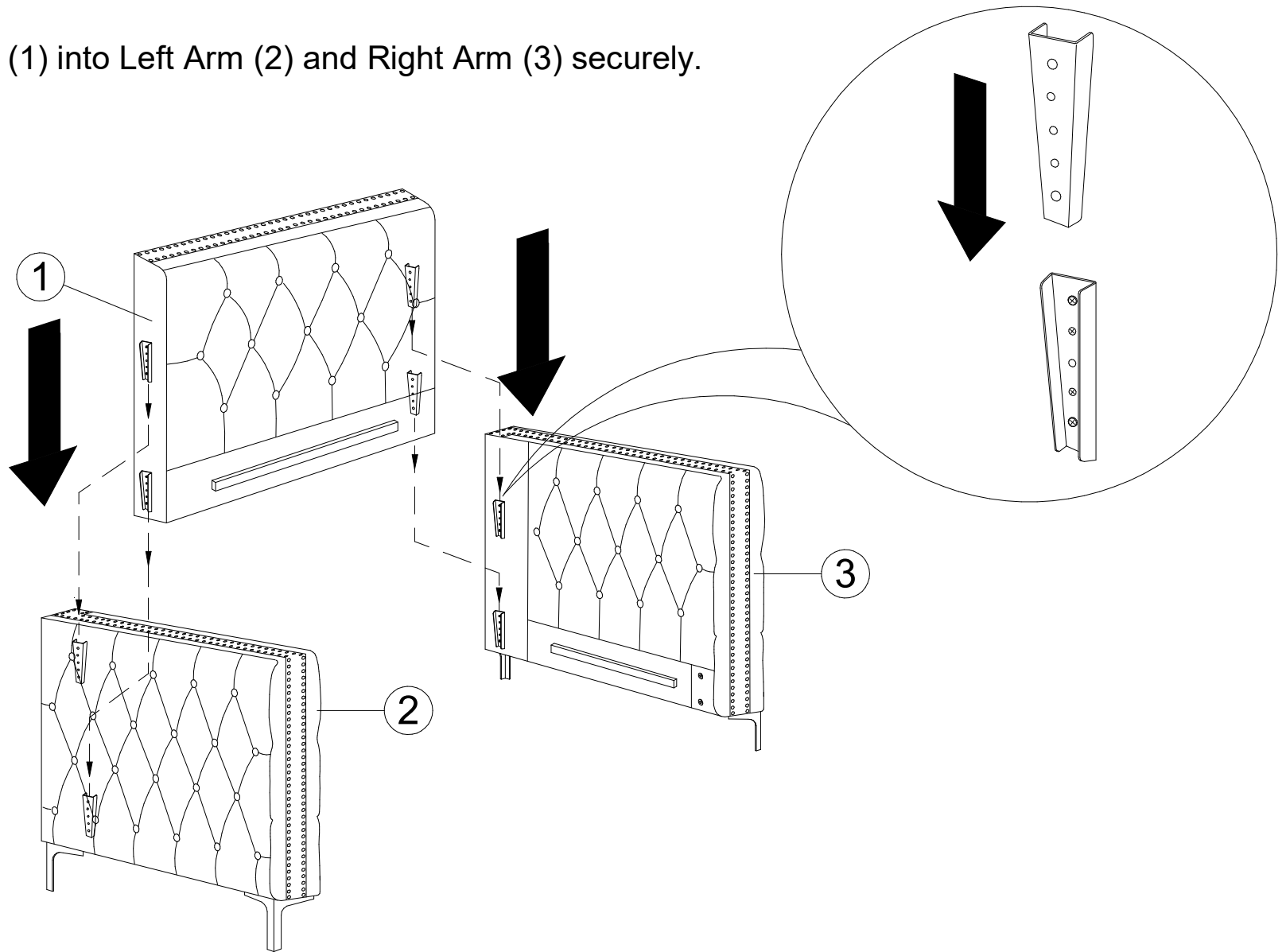

# ASSEMBLY INSTRUCTION

## STEP 5.

Slightly loosen the four bolts using Allen Key (A) without removing the bolts completely from both Side Arms (2 and 3). Hook on Front Rail (5) hooks into loosen bolts, once placed tighten and secure all four bolt with Allen Key (A).

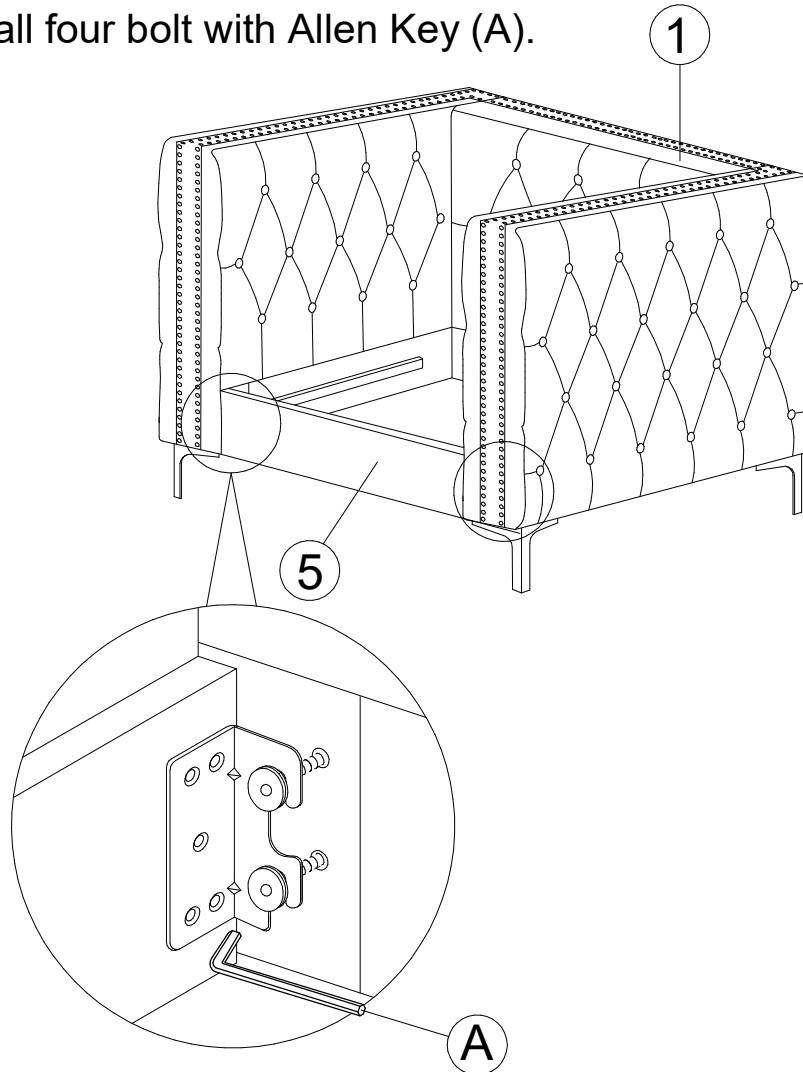

## STEP 6.

Lay the Seat Panel (6) on top of units frame.

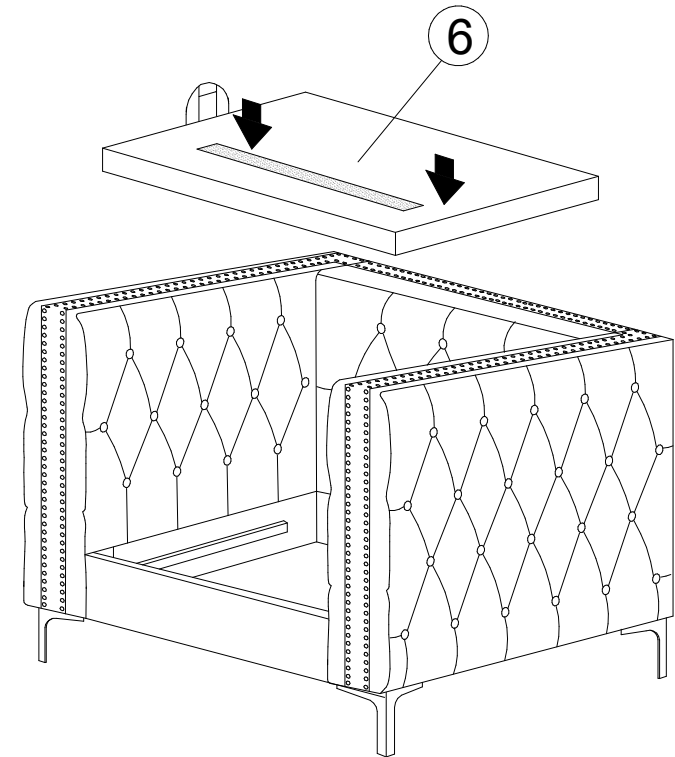

# ASSEMBLY INSTRUCTION

## STEP 7.

Attach the Seat Cushion (8) (1pc).

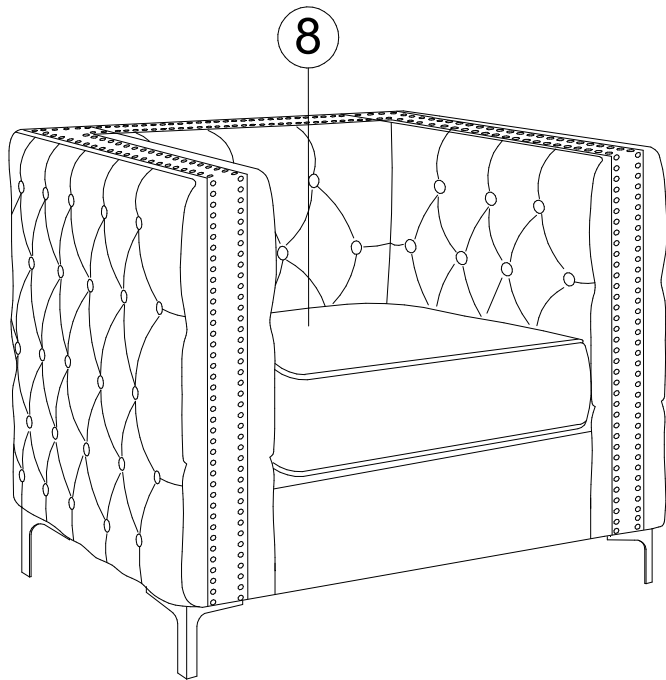

Attach the Seat Cushion (8) (1pc).

## STEP 8.

Lay Pillows (7) (1pc).

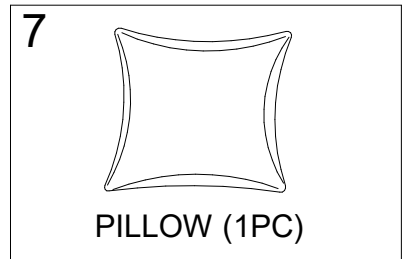
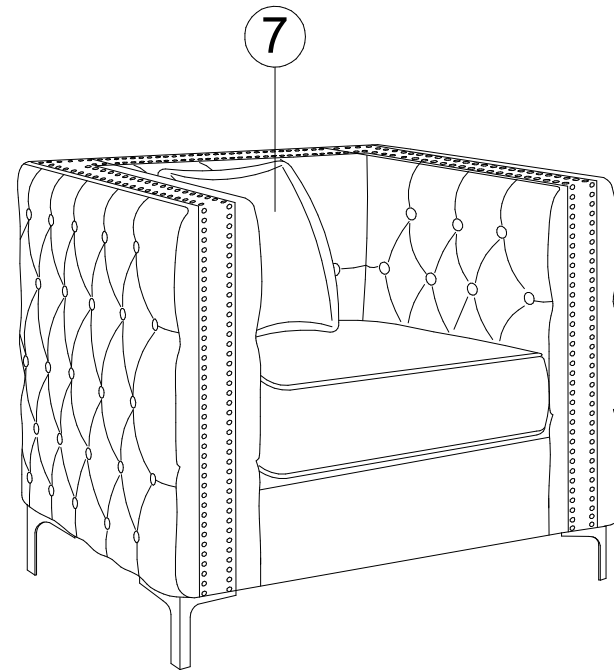

Lay Pillows (7) (1pc).