

**TWIN / FULL BUNK BED**  
**LIT SUPERPOSABLE JUMEAU / DOUBLE**  
**LITERA GEMELA / DOBLE**

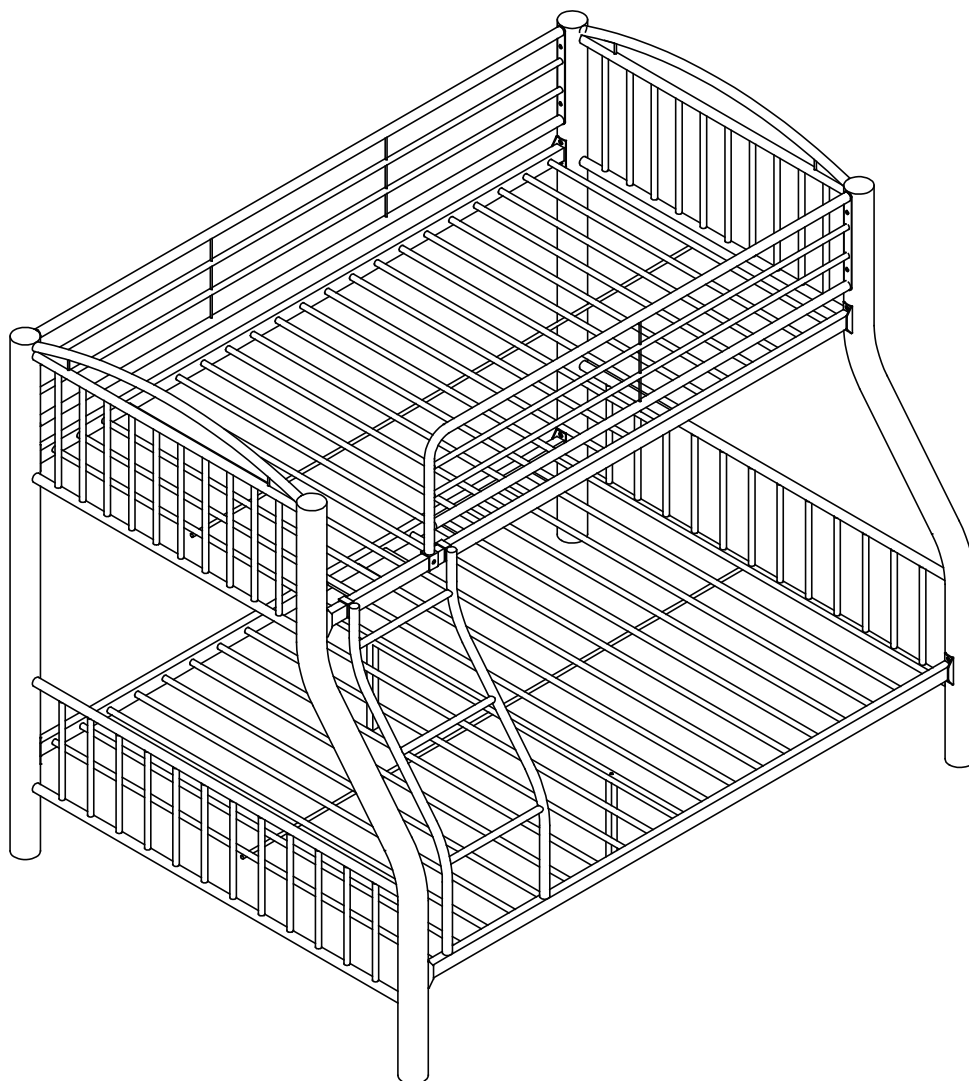

## **We are here to help!**

### **Before you return it - contact us.**

We do our best to insure that your furniture arrives in excellent condition. In the event that a part is damaged or missing, we will be happy to provide you with replacement parts, at no charge, within 30 days of purchase, providing the parts are available in our warehouse and the item purchased is part of our current inventory. In order to receive spare parts, at no charge, you must provide proof of purchase within 30 days.

If you need assistance with assembly or replacement parts, please call Customer Service, prior to returning the item to the store.

## **Nous sommes là pour vous aider!**

### **Avant de retourner le produit, veuillez communiquer avec nous.**

Nous faisons tout en notre pouvoir pour que vous receviez votre meuble en parfait état. Toutefois, si une pièce est endommagée ou manquante, nous se fera un plaisir de vous envoyer gratuitement la pièce de rechange, dans les 30 jours suivant l'achat, à condition que nous ayons la pièce en stock et que le produit acheté fasse partie de notre inventaire courant. Afin de recevoir gratuitement la pièce de rechange, vous devez fournir une preuve d'achat dans un délai de 30 jours.

Si vous avez besoin d'une pièce de rechange ou d'aide pour l'assemblage, veuillez communiquer avec le Service à la clientèle de avant de retourner le produit au magasin.

## **¡Estamos aquí para ayudarle!**

### **Antes de regresar el producto, comuníquese con nosotros.**

Hacemos todo lo posible para que su mobiliario se le entregue en excelentes condiciones. En caso de que falte una pieza o esté dañada, nosotros le enviará con gusto la pieza de repuesto sin ningún costo dentro de los 30 días posteriores a la compra, siempre y cuando tengamos en existencia las piezas en nuestros almacenes y que el artículo comprado forme parte de nuestro inventario actual. Para recibir piezas de repuesto, sin costo adicional, debe enviarnos el comprobante de compra dentro de los 30 días después de la compra.

Si necesita ayuda para ensamblar su producto o para obtener piezas de repuesto, llame al Servicio al Cliente de antes de devolver el artículo a la tienda.







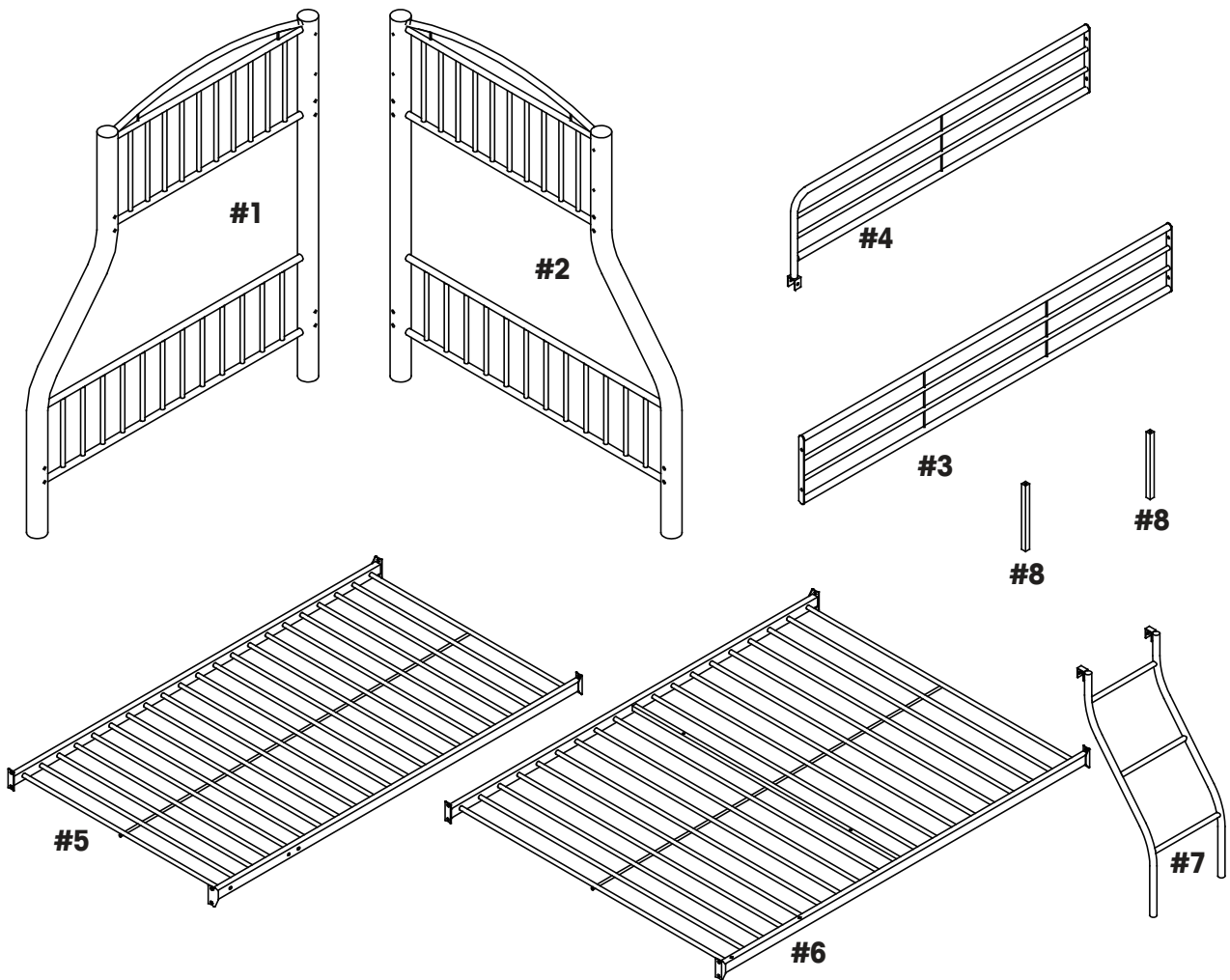

## PART LIST

#1	LEFT PANEL	01
#2	RIGHT PANEL	01
#3	BACK GUARDRAIL	01
#4	FRONT GUARDRAIL	01

#5	UPPER BED FRAME	01
#6	LOWER BED FRAME	01
#7	LADDER	01
#8	SUPPORT LEG	02



## HARDWARE LIST

<b>A</b>	<b>BOLT (Ø5/16"x2-1/2")</b>		<b>02</b>
<b>B</b>	<b>BOLT (Ø1/4"x1-3/4")</b>		<b>04</b>
<b>C</b>	<b>BOLT (Ø5/16"x3/4")</b>		<b>16</b>
<b>D</b>	<b>BOLT (Ø1/4"x3/4")</b>		<b>07</b>
<b>E</b>	<b>FLAT WASHER (Ø3/4")</b>		<b>18</b>
<b>F</b>	<b>FLAT WASHER (Ø5/8")</b>		<b>11</b>
<b>G</b>	<b>SPRING WASHER (Ø1/2")</b>		<b>18</b>
<b>H</b>	<b>SPRING WASHER (Ø7/16")</b>		<b>11</b>
<b>I</b>	<b>NUT</b>		<b>01</b>

## TOOLS REQUIRED



<b>ALLEN KEY</b>		<b>SUPPLIED</b>
<b>ALLEN KEY</b>		<b>SUPPLIED</b>

### IMPORTANT:

1. Do not tighten bolts completely until all bolts are completely lined up and inserted into holes / nuts.
2. Do not over tighten screws and bolts to avoid stripping.
3. Please use hand tools to assemble this product. Do not use power tools.

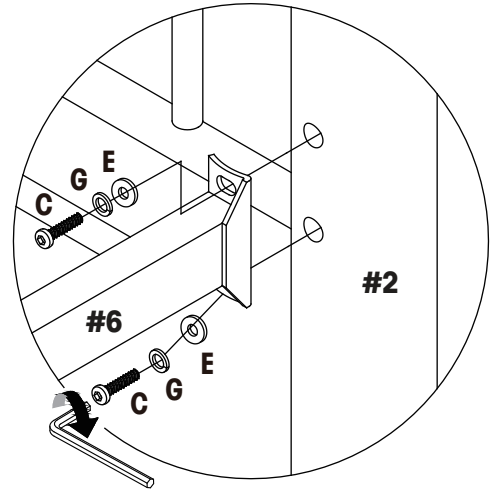
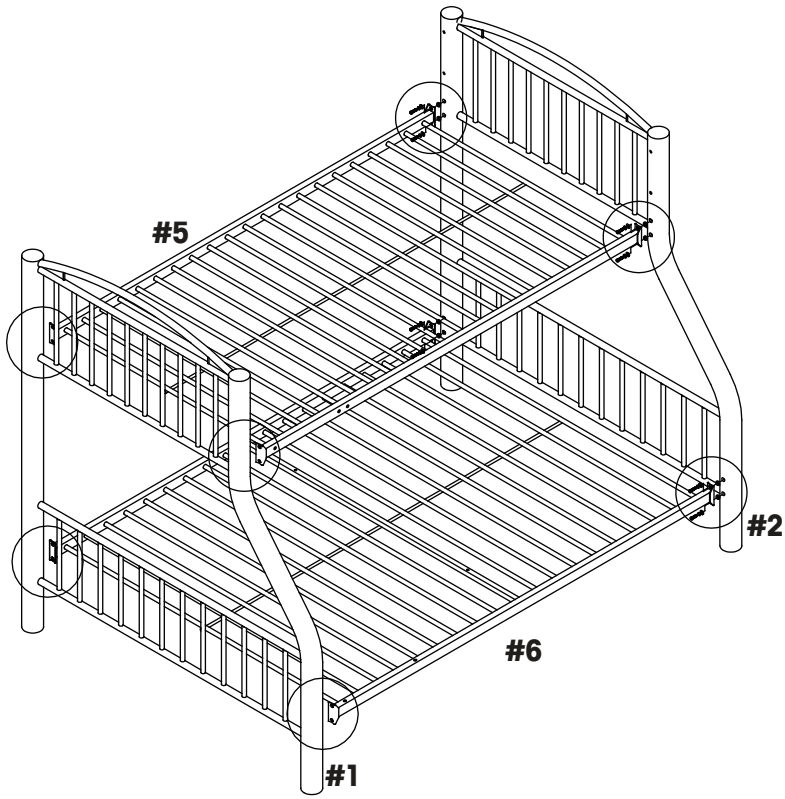

1.



C		16
G		16
E		16

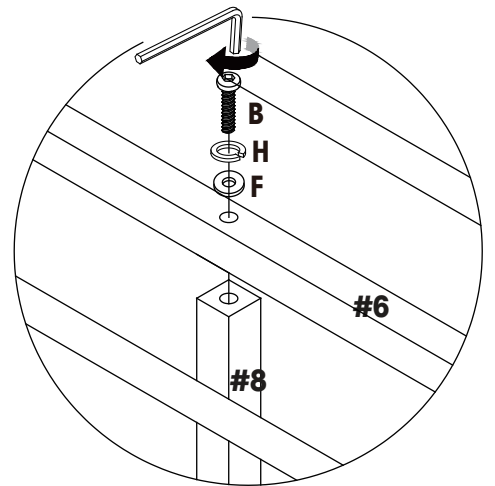
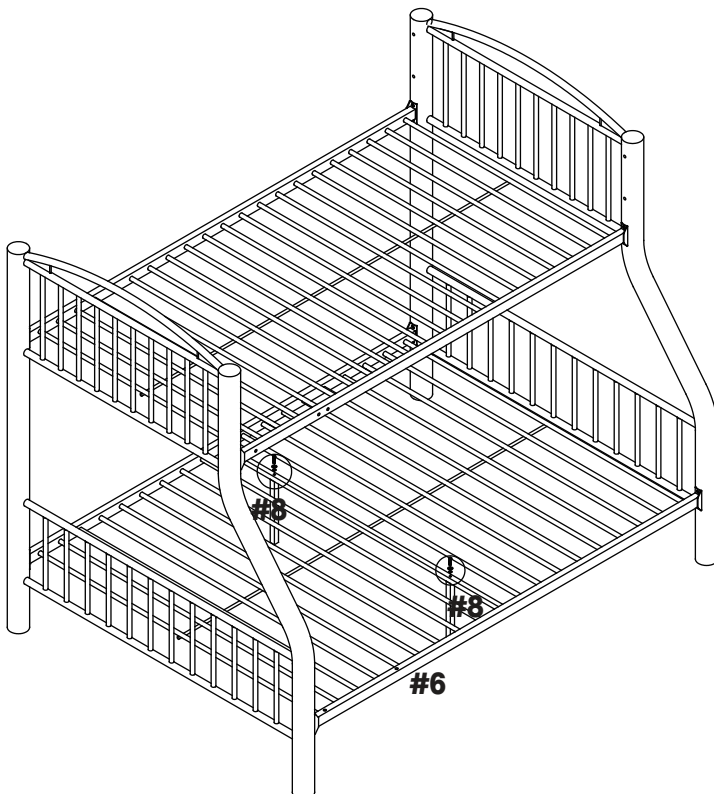





2.

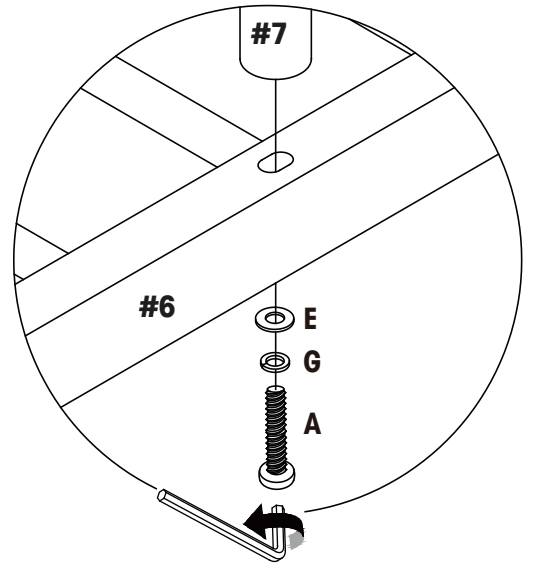
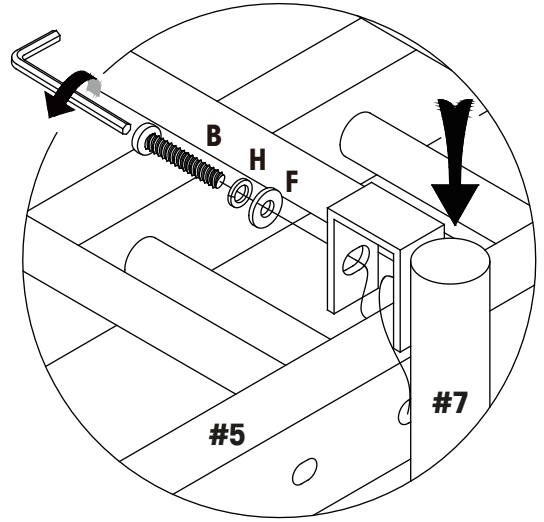
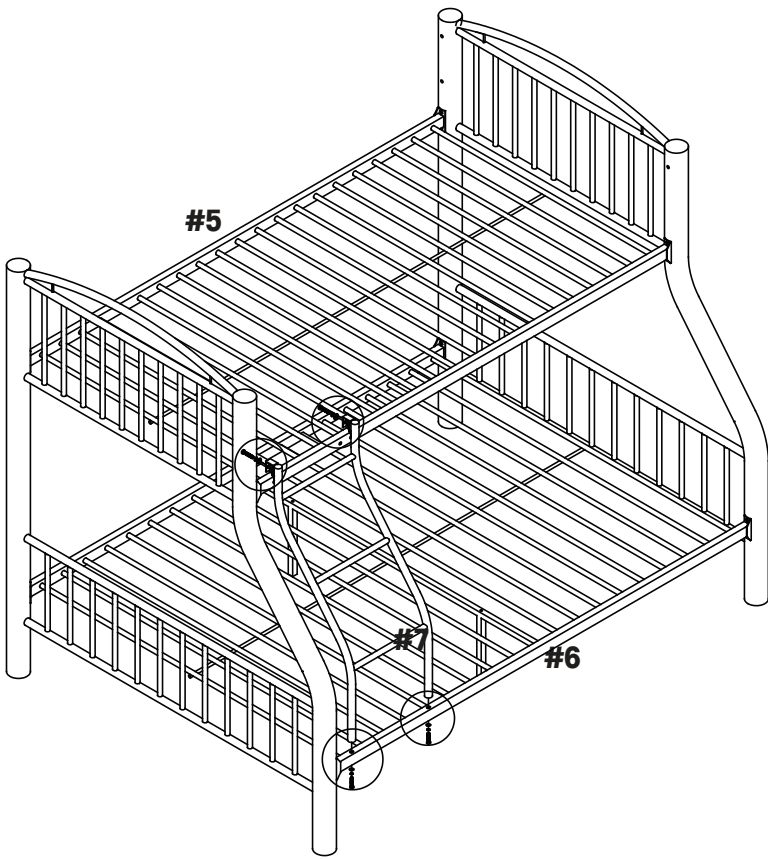

B		02
H		02
F		02





3.

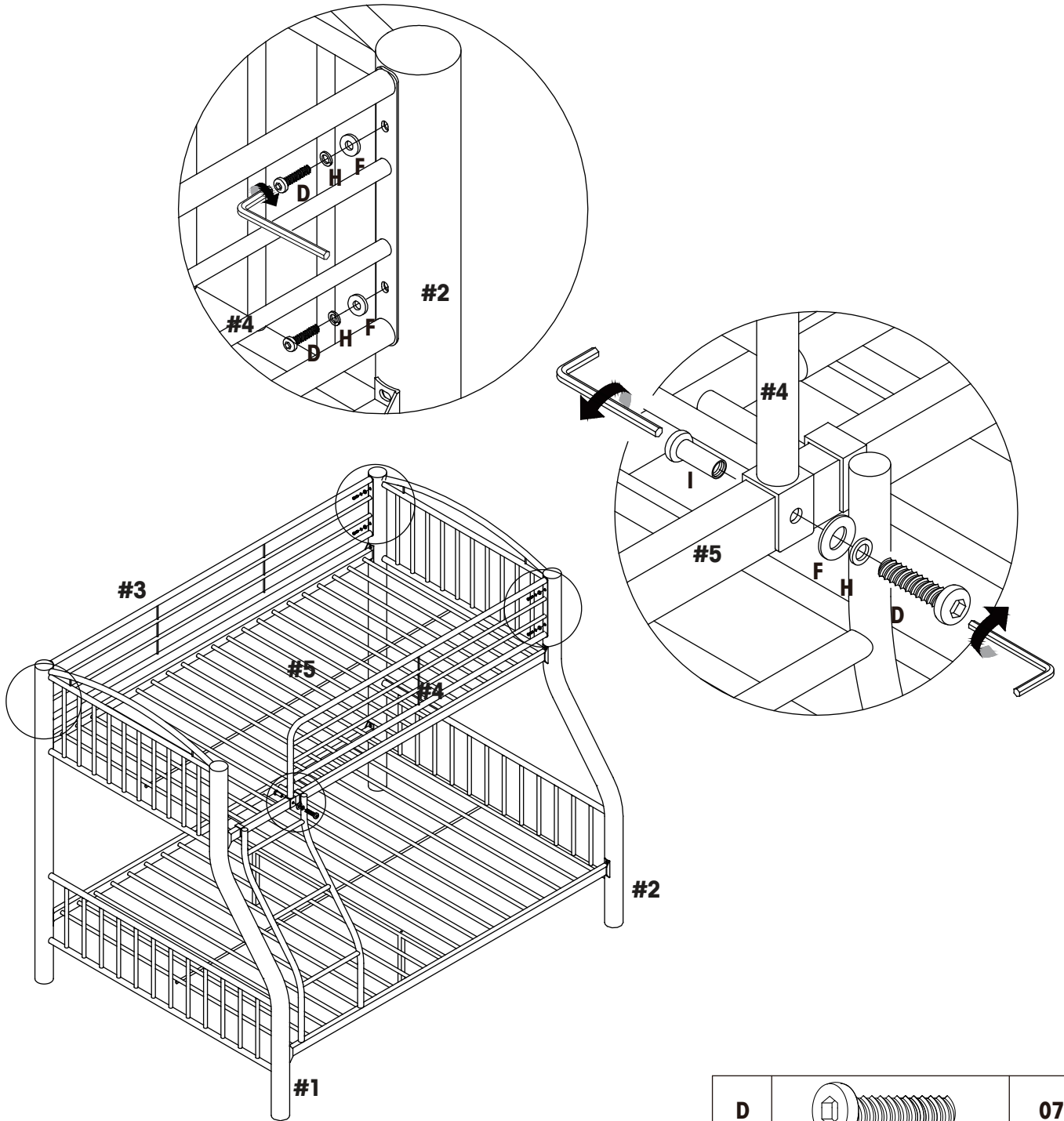

A		02
G		02
E		02
B		02
H		02
F		02

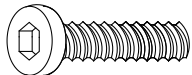
4.



D		07
H		07
F		07
I		01

5.

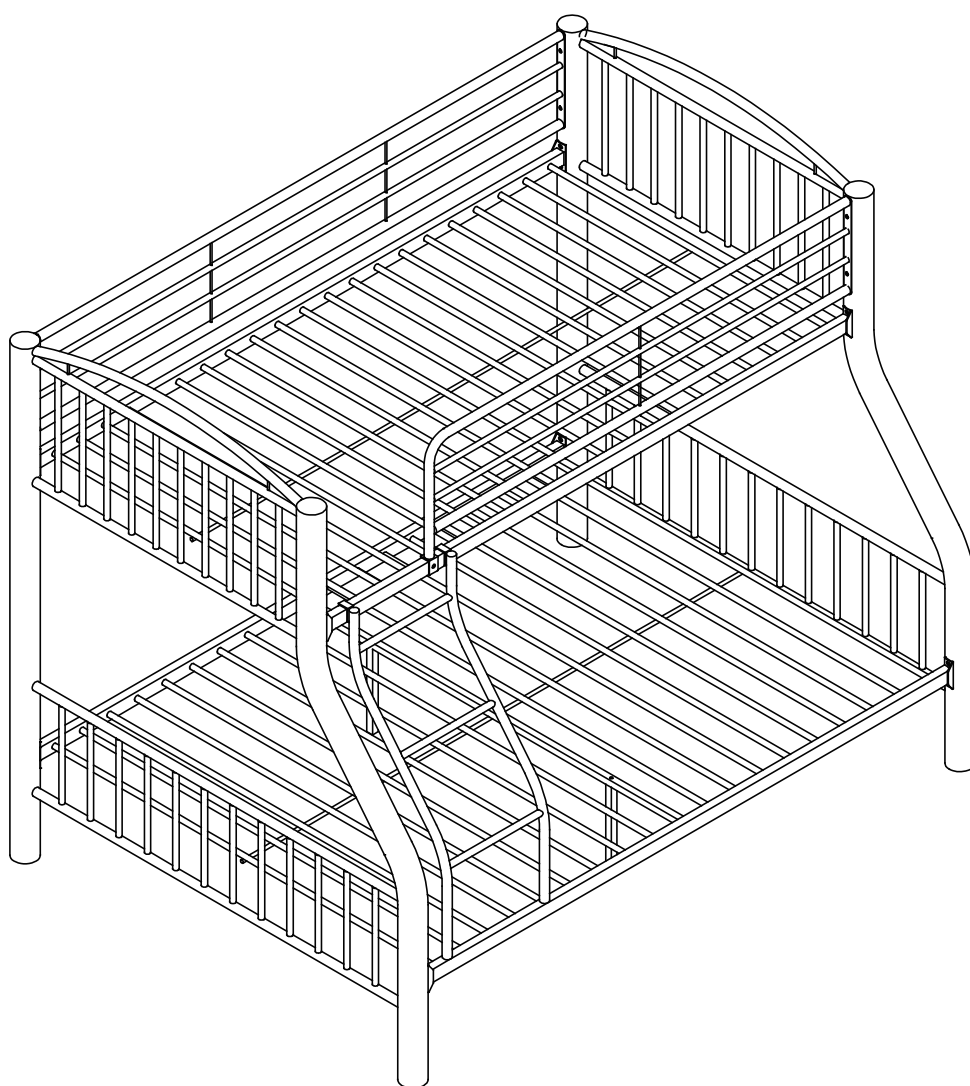



**WARNING TO HELP PREVENT SERIOUS OR FATAL INJURIES FROM ENTRAPMENT OR FALLS:**

- Never allow a child under 6 years old on the upper bunk.
- Always use the recommended size mattress or mattress support, or both, to help prevent the likelihood of entrapment or falls.
- Use only a mattress which is 74" ~ 75" x 37-1/2" ~ 38-1/2" x 6" on the upper bunk, 74" ~ 75" x 53" ~ 54" on the lower bunk.
- Ensure thickness of mattress does not exceed 8" and surface of mattress is at least 5" below upper edge of guardrails.
- Always use guardrails on both long sides of the upper bunk.
- If bunk bed will be placed next to a wall, the guardrail that runs the full length of the bed should be placed against the wall to prevent entrapment between the bed and the wall.
- Prohibit horseplay on or under bed(s) and prohibit jumping on the bed.
- Prohibit more than one person on upper bunk.
- Use ladder for entering and leaving upper bunk.
- Maximum total weight is not to exceed 300 lbs. on the upper bunk.
- Periodically check and ensure that the guardrail, ladder, and other components are in their proper position, free from damage, and that all connectors are tight.
- Do not use substitute parts. Replacement parts, including additional guardrails, may be obtained from our customer service department.
- Use of water or sleep flotation mattresses is prohibited.
- Use of a night light may provide added safety precaution for a child using the upper bunk.
- Follow the information on the warnings appearing on the upper bunk end structure and on the carton
- Keep these instructions for future reference.

**STRANGULATION HAZARD** Never attach or hang items to any part of the bunk bed that are not designed for use with the bed; for example, but not limited to, hooks, belts and jump ropes.

**DO NOT REMOVE THIS LABEL, KEEP THESE INSTRUCTIONS FOR FUTURE REFERENCE.**

# **LIMITED 6 MONTHS WARRANTY**

## **GARANTIE LIMITÉE DE 6 MOIS**

## **GARANTÍA LIMITADA DE 6 MESES**

### **WHAT IS COVERED**

This product is covered under our manufacturer's 6 months limited warranty. To ensure your complete satisfaction, this warrants to the original purchaser that the supplied item is free from defects in material and workmanship, as of the date of purchase, and that it will, under normal use and proper care, remain so for six months after the date of purchase.

Replacement of missing or initially defective parts will be sent, at no charge, for a period of 30 days from the date of purchase with valid proof of purchase providing the parts are available in our warehouse and the item purchased is part of our current inventory.

### **WHAT IS NOT COVERED**

It remains the customer's responsibility for freight and packaging charges to and from the customer service center. Labor and material charges to remove or replace parts under this warranty are not covered.

This warranty does not cover: Furniture used for commercial purposes, failures caused by improper installation assembly or by improper care, unreasonable or abusive use, freeze damage, acts of God, rust, purchased parts or return freight and packaging charges. Proof of purchase (dated register receipt) is required for warranty claims.

### **HOW TO OBTAIN SERVICE**

For further information, please contact our customer service department,

### **QU'EST-CE QUI EST COUVERT**

Ce produit est couvert sous une garantie limitée de 6 mois offerte par le fabricant. Afin d'assurer votre entière satisfaction, cela garantit à l'acheteur original que le produit fourni est exempt de défauts de matériaux et de fabrication à compter de la date d'achat, et ce, sous des conditions d'utilisation normales et de soins adéquats, valide pendant six mois après la date d'achat.

Le remplacement de pièces manquantes ou défectueuses dès le départ sera envoyé, sans frais, pour une période de 30 jours suivant la date d'achat avec une preuve d'achat valide pourvu que les pièces soient disponibles dans notre entrepôt et que l'article acheté fait partie de notre inventaire actuel.

### **QU'EST-CE QUI N'EST PAS COUVERT**

Il y a de la responsabilité du client de couvrir les frais de transport et d'emballage vers et à partir du centre de service après-vente. Les frais de la main-d'œuvre et des matériaux pour retirer les pièces ou les remplacer sous cette garantie ne sont pas couverts.

Cette garantie ne couvre pas : les meubles utilisés à des fins commerciales, les défaillances causées par un mauvais assemblage ou entretien (sans dépasser les limites de poids), l'utilisation déraisonnable ou abusive, les dommages causés par le gel, la rouille, les frais de transport et d'emballage pour des pièces achetées ou retournées. Une preuve d'achat (reçu de caisse daté) est requise pour les réclamations sous garantie.

### **COMMENT FAIRE POUR OBTENIR DU SERVICE**

Pour de plus amples renseignements, veuillez communiquer avec notre département du service à la clientèle

### **QUÉ ESTÁ CUBIERTO**

Este producto está cubierto por la garantía limitada de 6 meses de nuestro fabricante. Para asegurar su total satisfacción, ésta garantiza al comprador original que el artículo proporcionado se encuentra libre de defectos materiales y de fabricación, a partir de la fecha de compra, y que permanecerá en tal estado, sometido a un uso normal y cuidados adecuados, durante los seis meses posteriores a la fecha de la compra.

Las partes faltantes o que presenten defectos al inicio de ese período de tiempo serán enviadas sin cargo, durante un lapso de 30 días a partir de la fecha de compra, mediante la presentación de un comprobante de compra válido, siempre que las partes estén disponibles en nuestro almacén y el artículo adquirido sea parte de nuestro inventario actual.

### **QUÉ NO ESTÁ CUBIERTO**

El cliente asumirá los costos de flete y empaque hacia y desde el centro de servicio de cliente. Los cargos de material y mano de obra para extraer o reemplazar partes en el marco de la garantía no están cubiertos.

Esta garantía no cubre: muebles utilizados con fines comerciales, fallas causadas por montaje de instalación inadecuados o uso indebido (se recomienda no exceder los límites de peso), uso no razonable o abusivo, daños por congelación, oxidación, partes compradas, flete de devolución y cargos de empaque. Se exigirá el comprobante de compra (la factura de registro con fecha) para hacer valer la garantía.

### **CÓMO OBTENER SERVICIO**

Si desea más información, póngase en contacto con nuestro departamento de servicio al cliente

MADE IN CHINA  
FABRIQUÉ EN CHINE  
HECHO EN CHINA

