

# Installation & Assembly

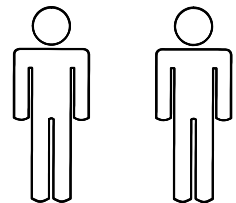

2 people for assembly

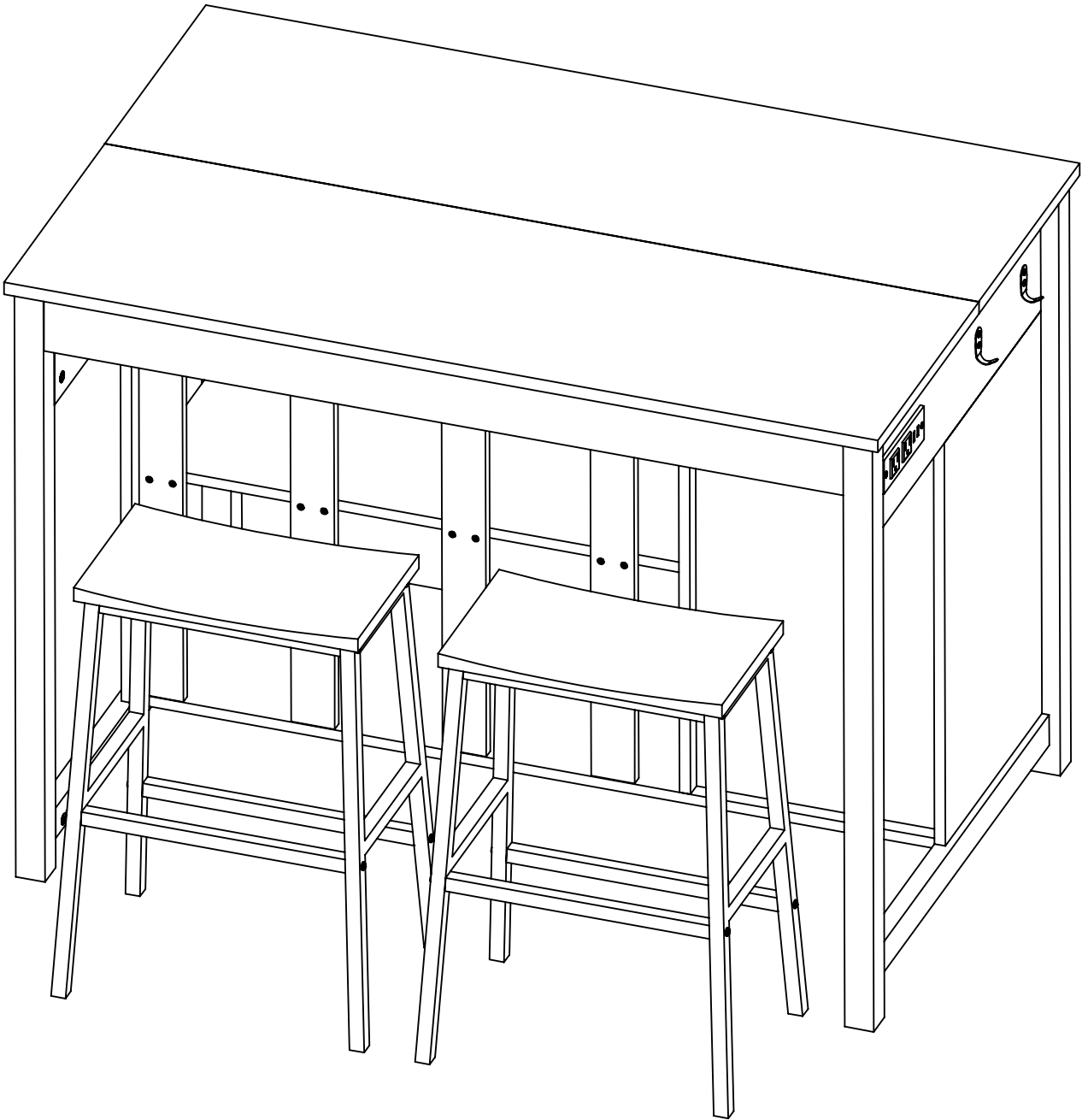

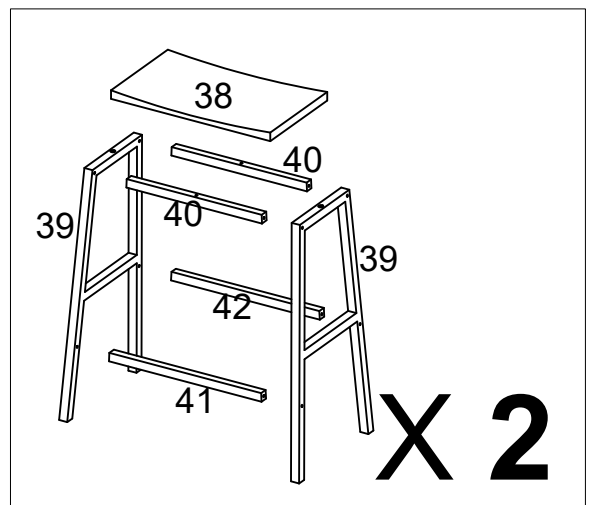
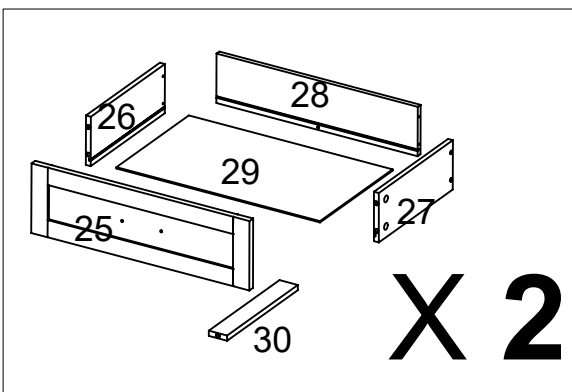
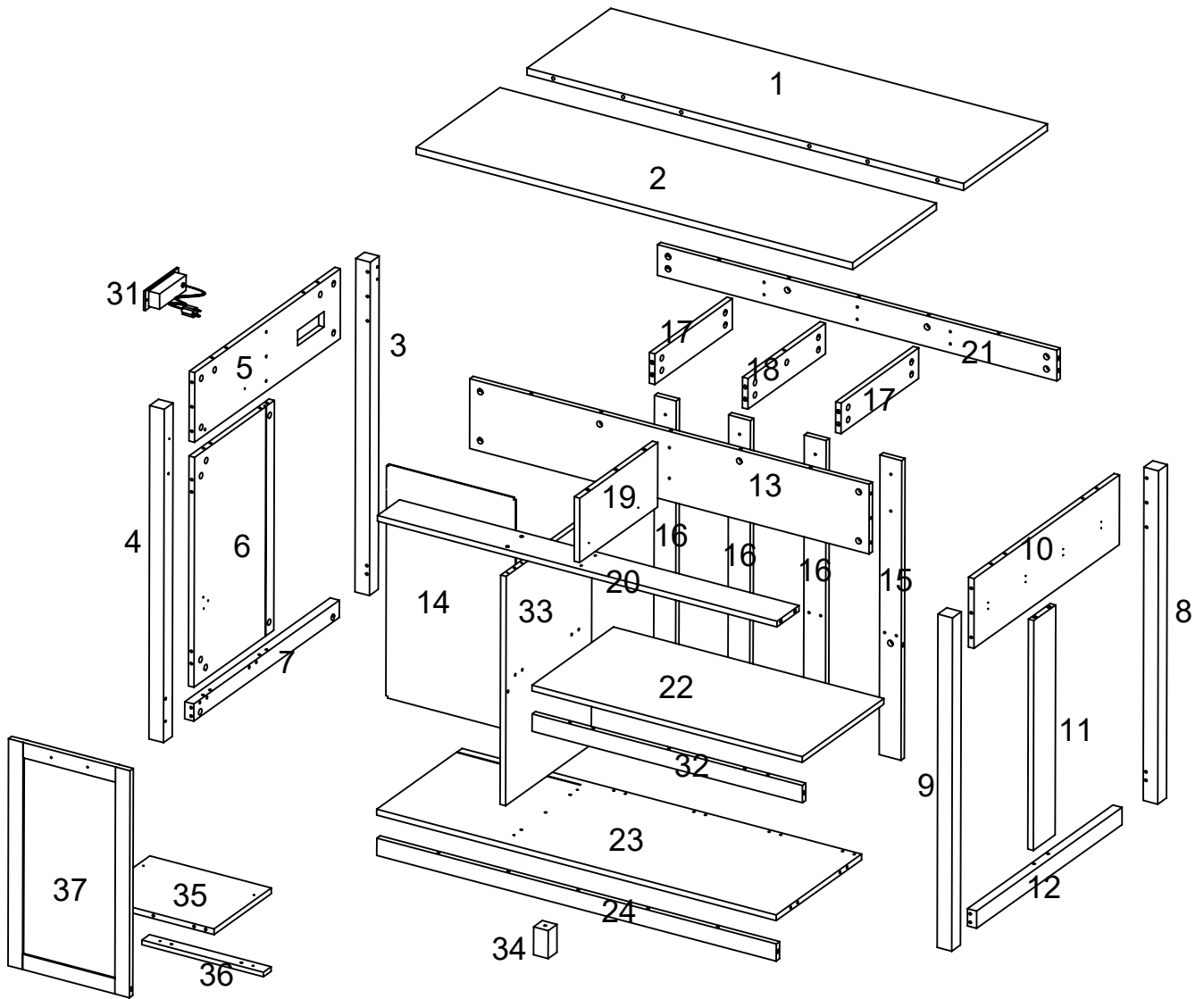





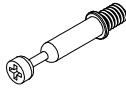
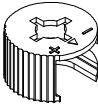
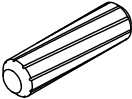
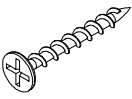
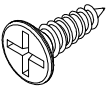

# PRODUCT ASSEMBLY

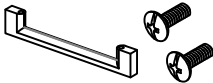
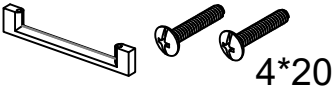

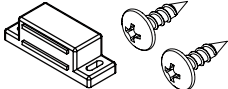
# Components - Fittings

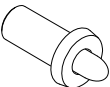
Please check you have all the panels listed below

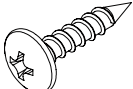
*Note:* The quantities below are the correct amount to complete the assembly. In some cases more fittings may be supplied than are required.

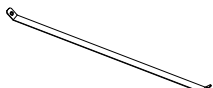
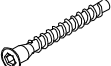
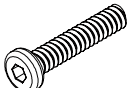
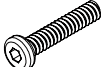
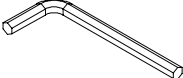
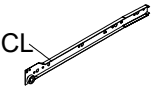
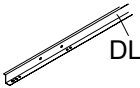
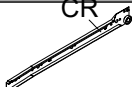
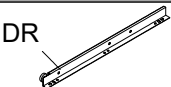
A		89 pcs +5 pcs	B		89 pcs +5 pcs
C	 6*30	42 pcs +4 pcs	D	 4*35	34 pcs +3 pcs
E	 3*12	36 pcs +3 pcs	F		6 pcs
G	 4*25	8 pcs	H		2 sets
I	 4*20	1 set	J	 8*50	4 pcs
K		1 set	L		1 pc
M		2 pcs	N		1 pc
O		2 pcs	P		2 pcs
Q		4 pcs	R		2 pcs
S		1 pc	T		16 pcs
U		8 pcs			1 pc
CL	 CL	2 pcs	DL	 DL	2 pcs
CR	 CR	2 pcs	DR	 DR	2 pcs

# PRODUCT ASSEMBLY

## Step 1

A		13 pcs
---	--	--------

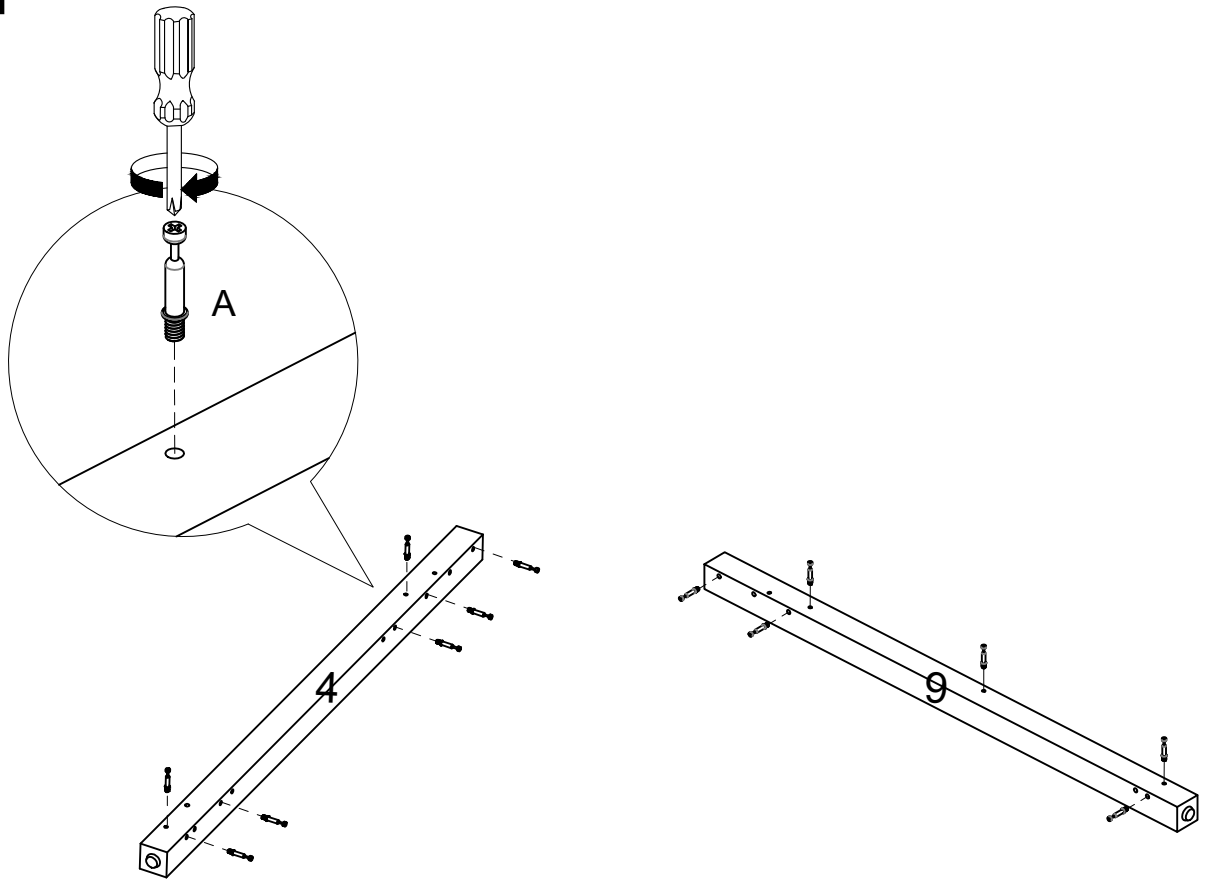

## Step 2

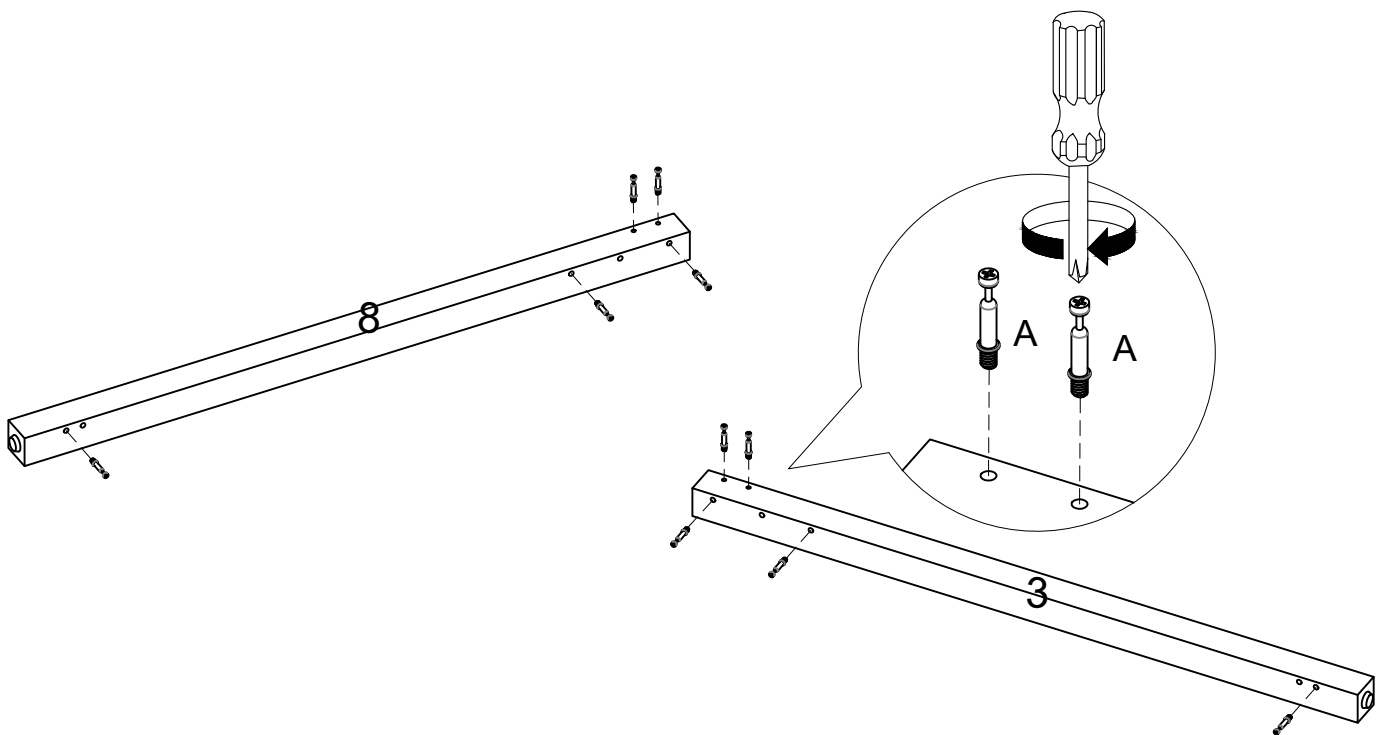

A		10 pcs
---	---	--------

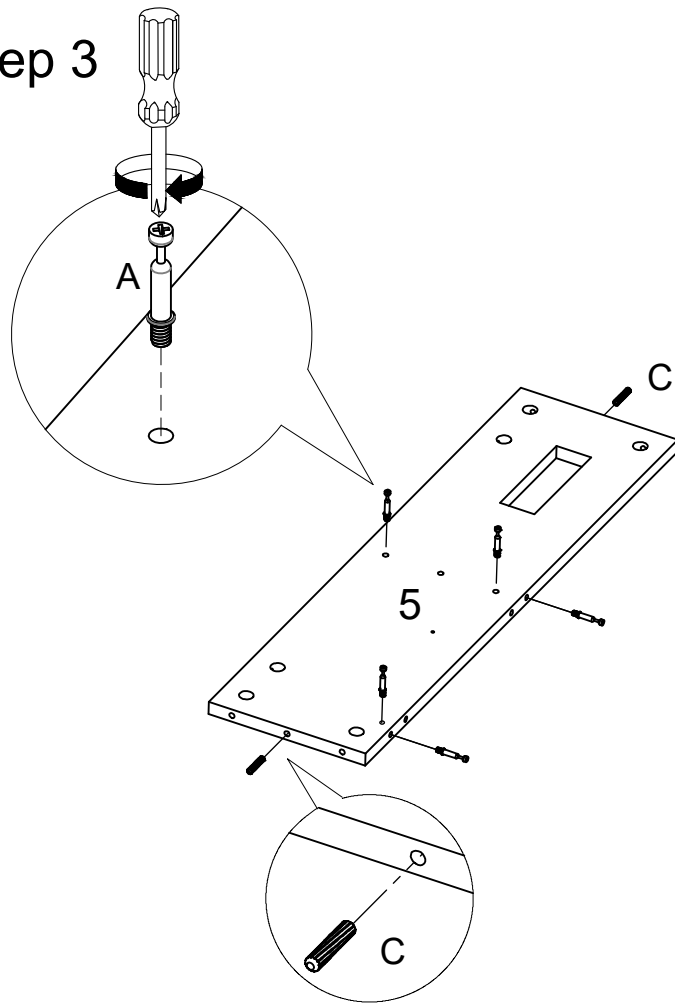

# PRODUCT ASSEMBLY

## Step 3



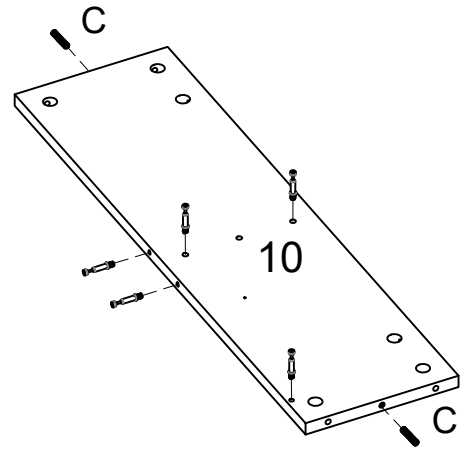

A		10 pcs
C		4 pcs

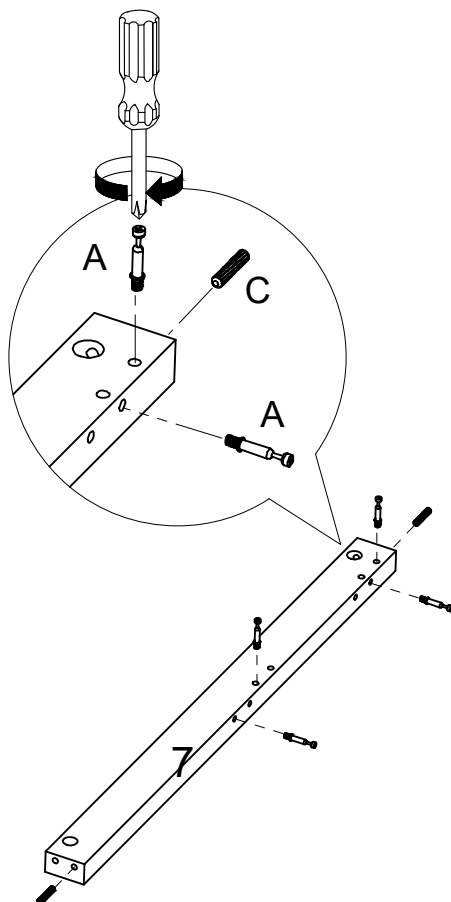

## Step 4



A		8 pcs
C		4 pcs

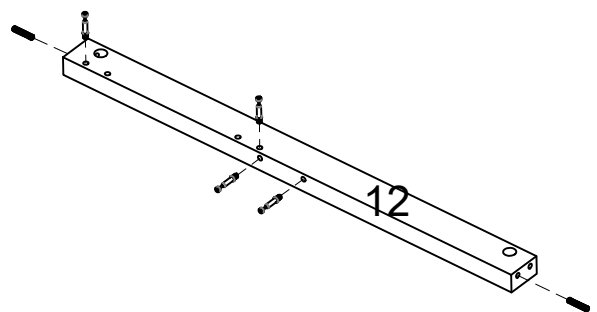

## Step 5

C		6 pcs
---	--	-------

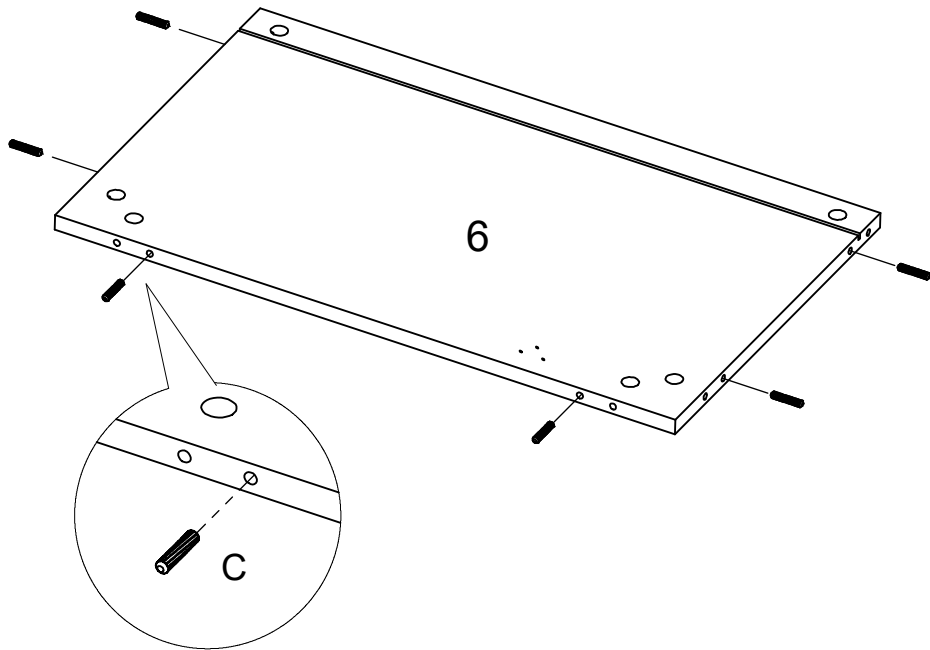

## Step 6

B		4 pcs
---	---	-------

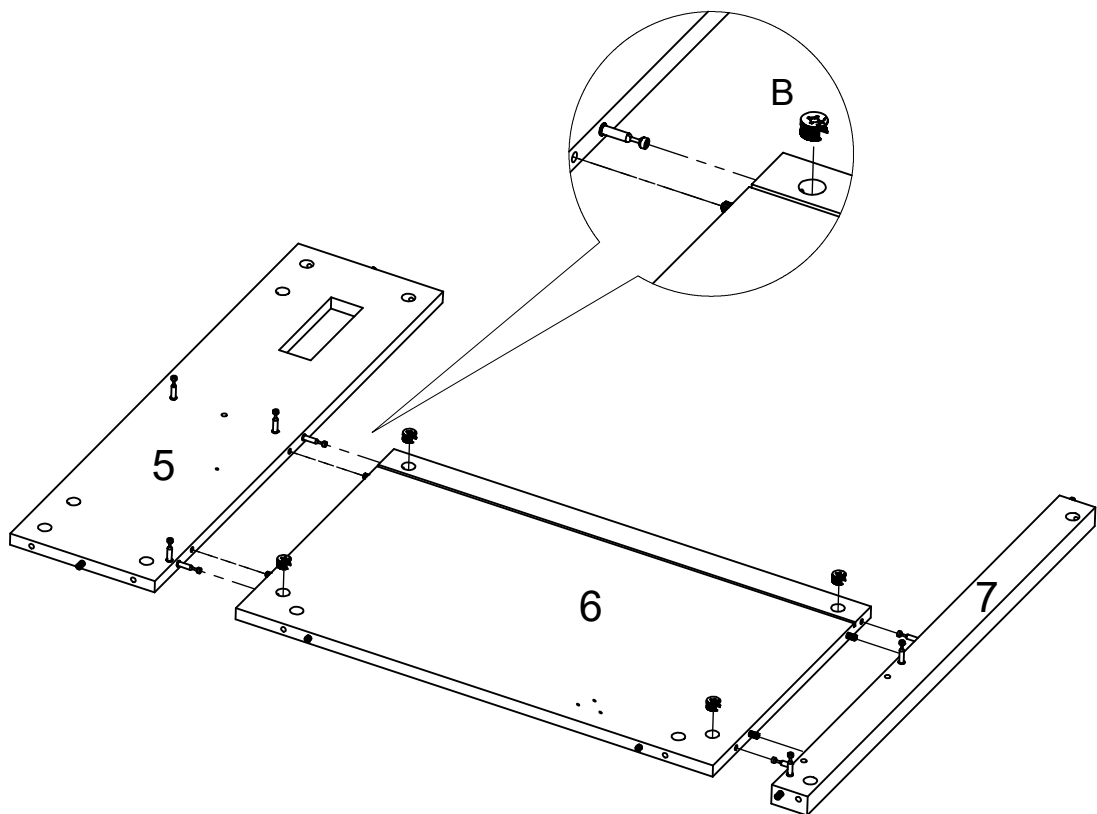

## Step 7

B		8 pcs
---	---	-------

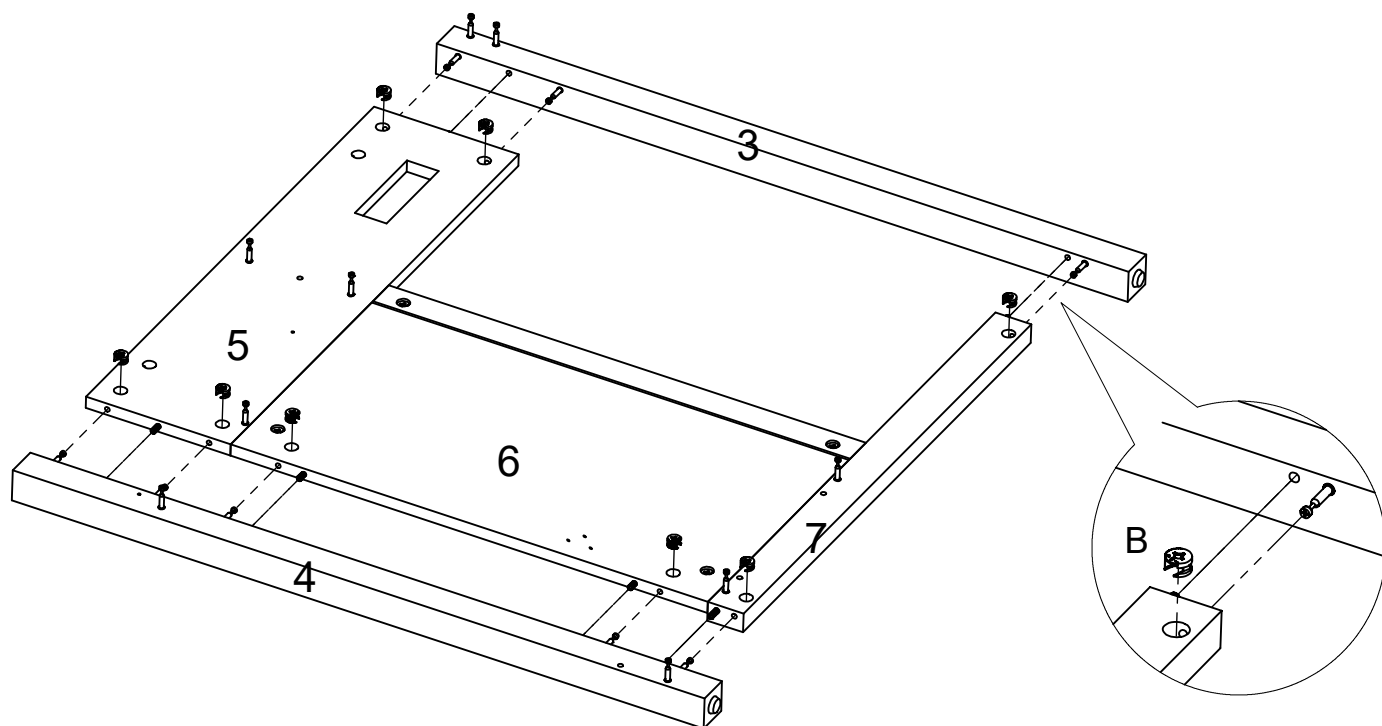

## Step 8

E		2 pcs
CL		1 pc

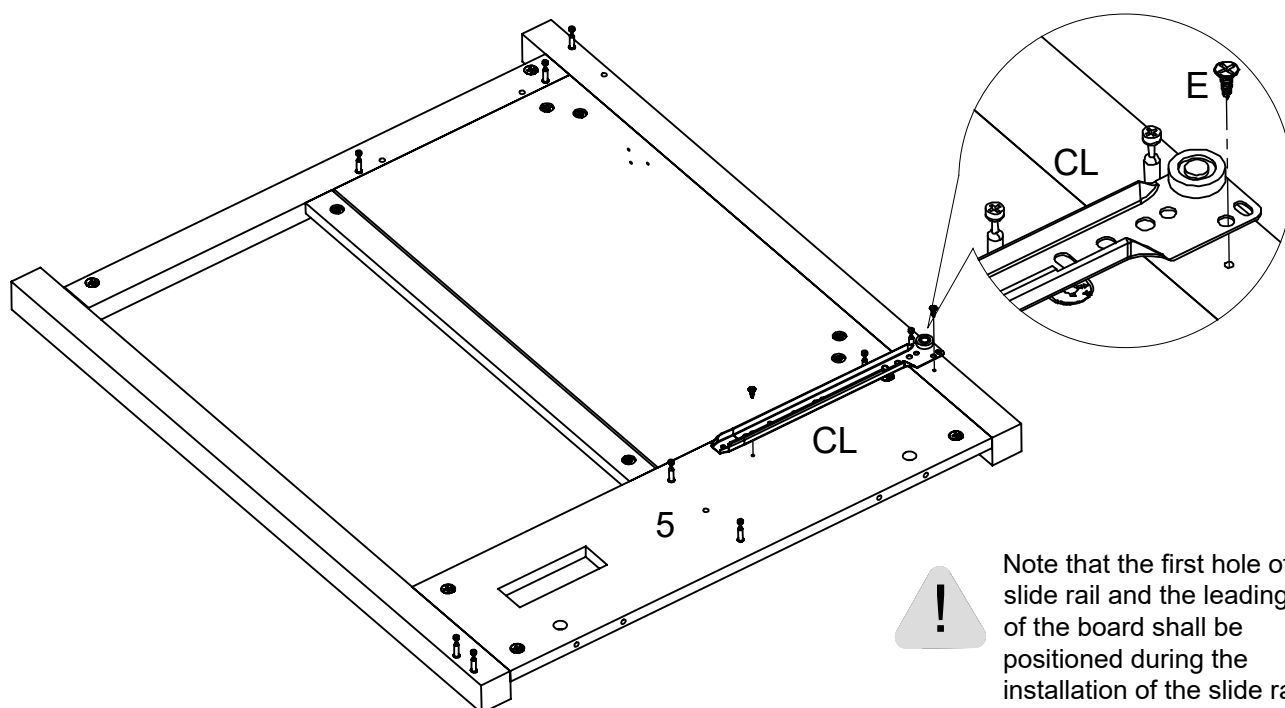

**!** Note that the first hole of the slide rail and the leading hole of the board shall be positioned during the installation of the slide rail!

B  4 pcs

## Step 9

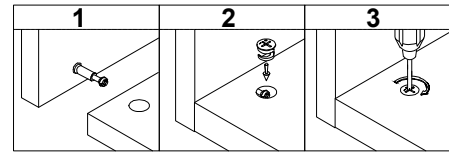
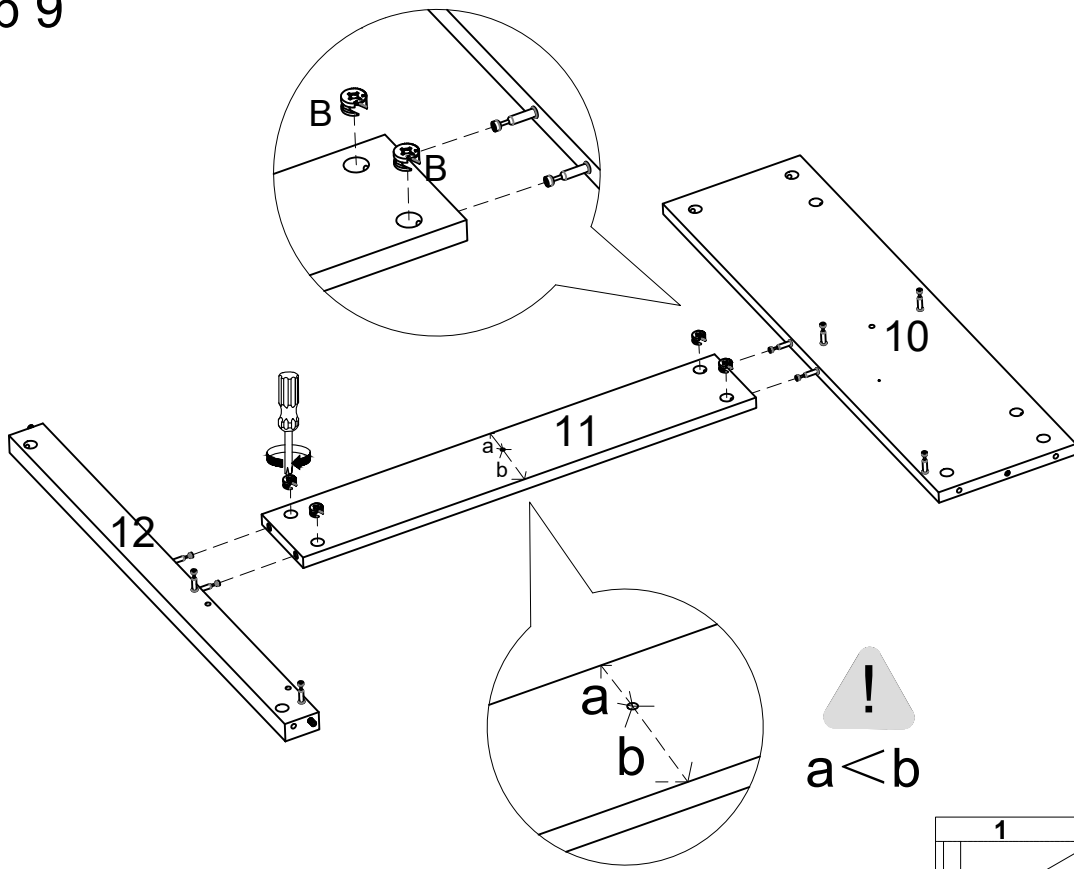

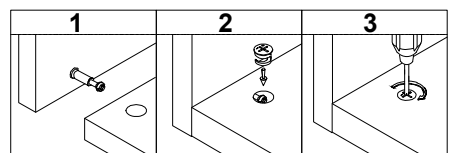
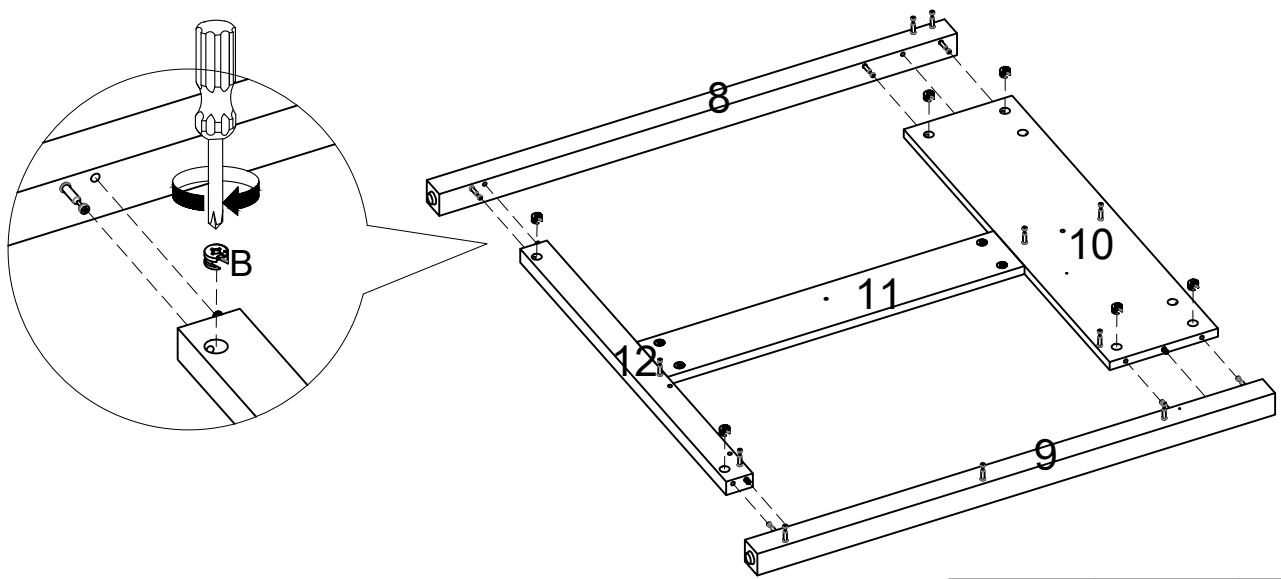

## Step 10

B  6 pcs



# PRODUCT ASSEMBLY

## Step 11

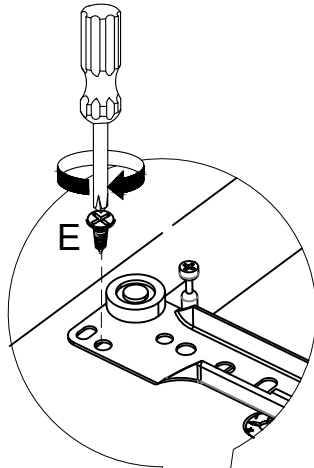

E		2 pcs
CR		1 pc
A		1 pc

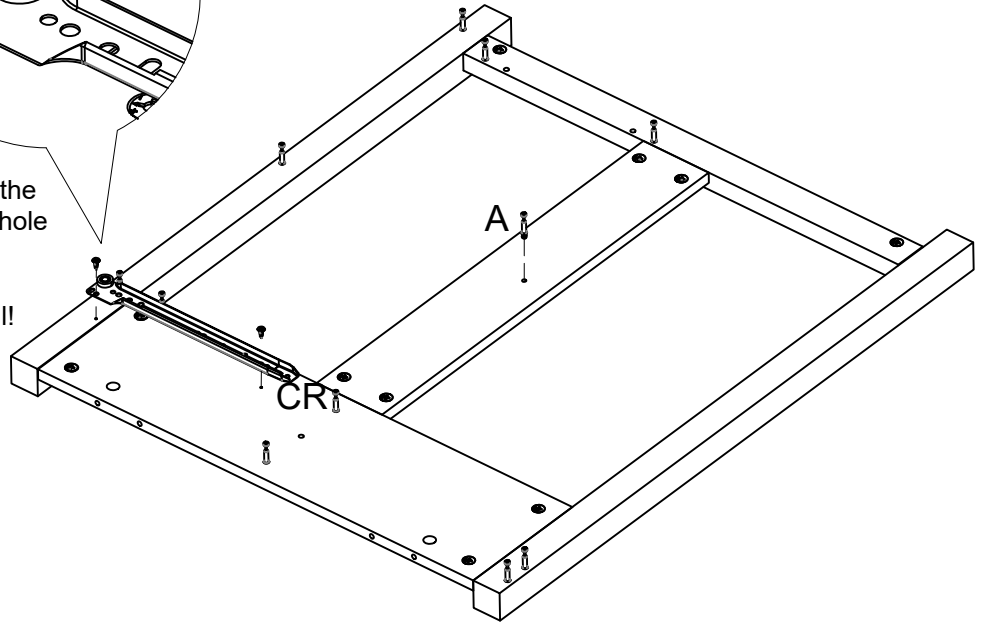

 Note that the first hole of the slide rail and the leading hole of the board shall be positioned during the installation of the slide rail!



## Step 12

CR		1 pc
CL		1 pc
E		4 pcs

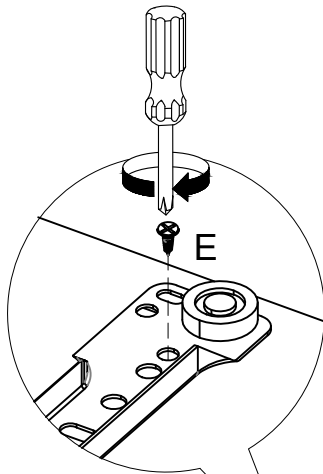

Note that the first hole of the slide rail and the leading hole of the board shall be positioned during the installation of the slide rail!

180°

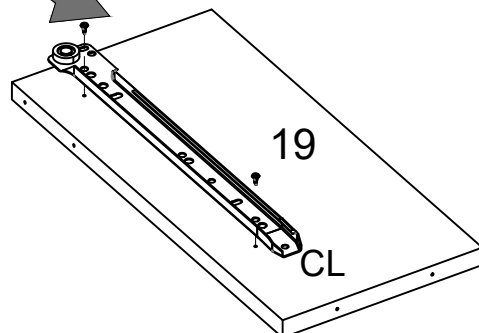
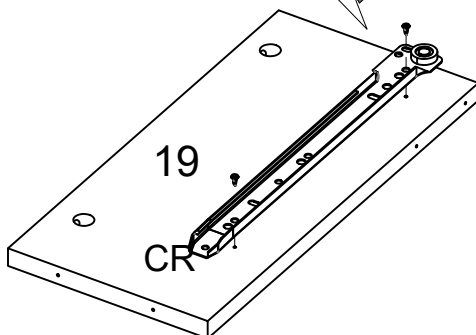

## Step 13

A		6 pcs
---	--	-------

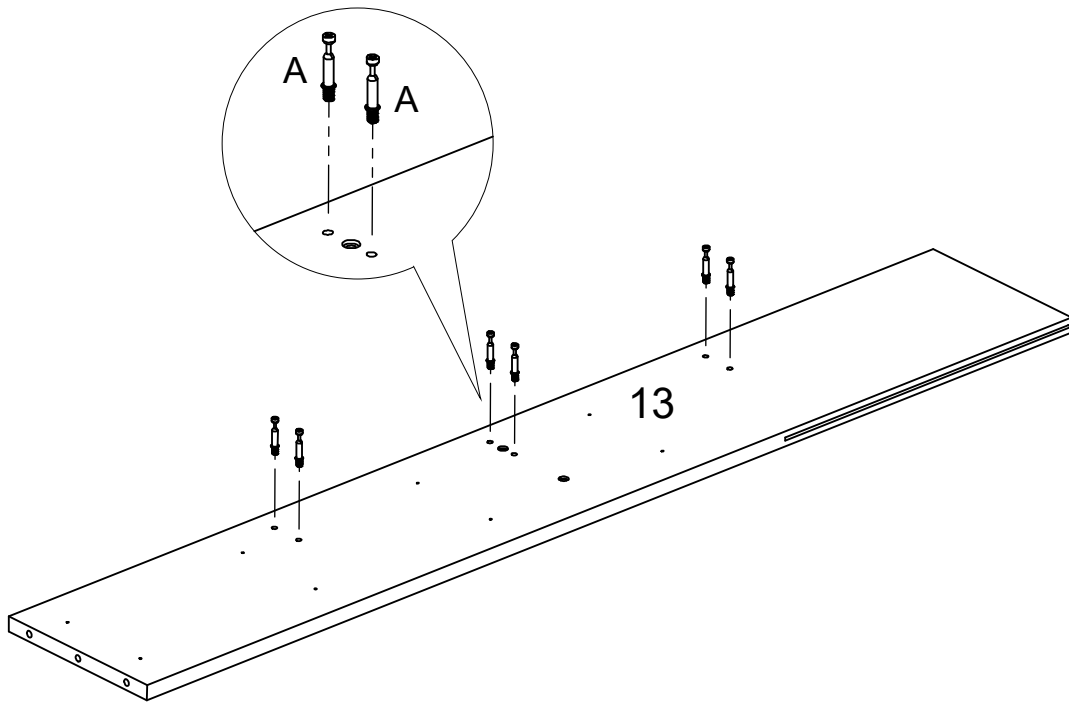

## Step 14

D		2 pcs
---	---	-------

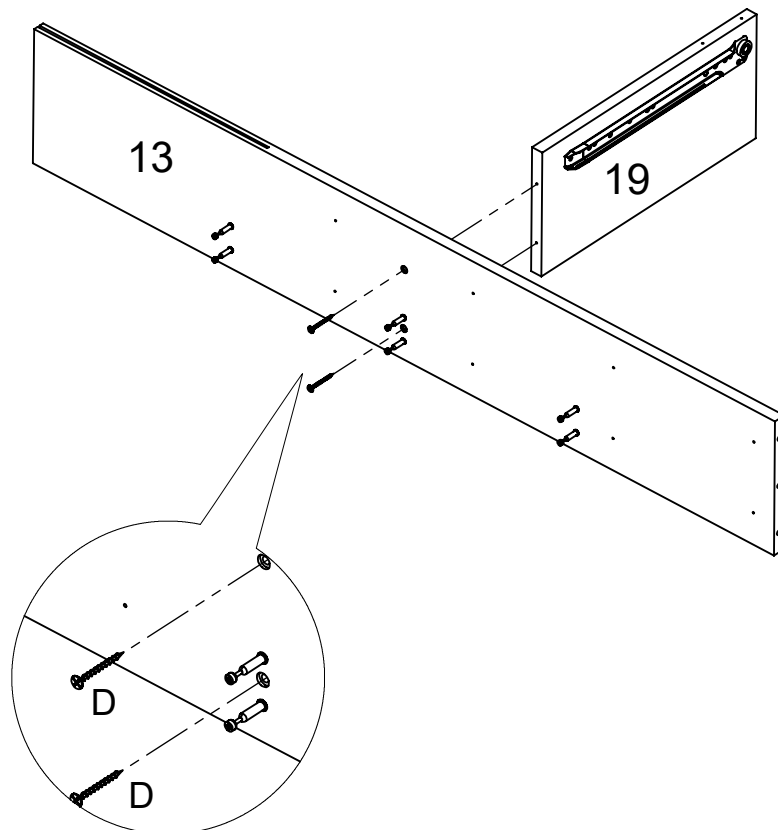

## Step 15

D		2 pcs
---	--	-------

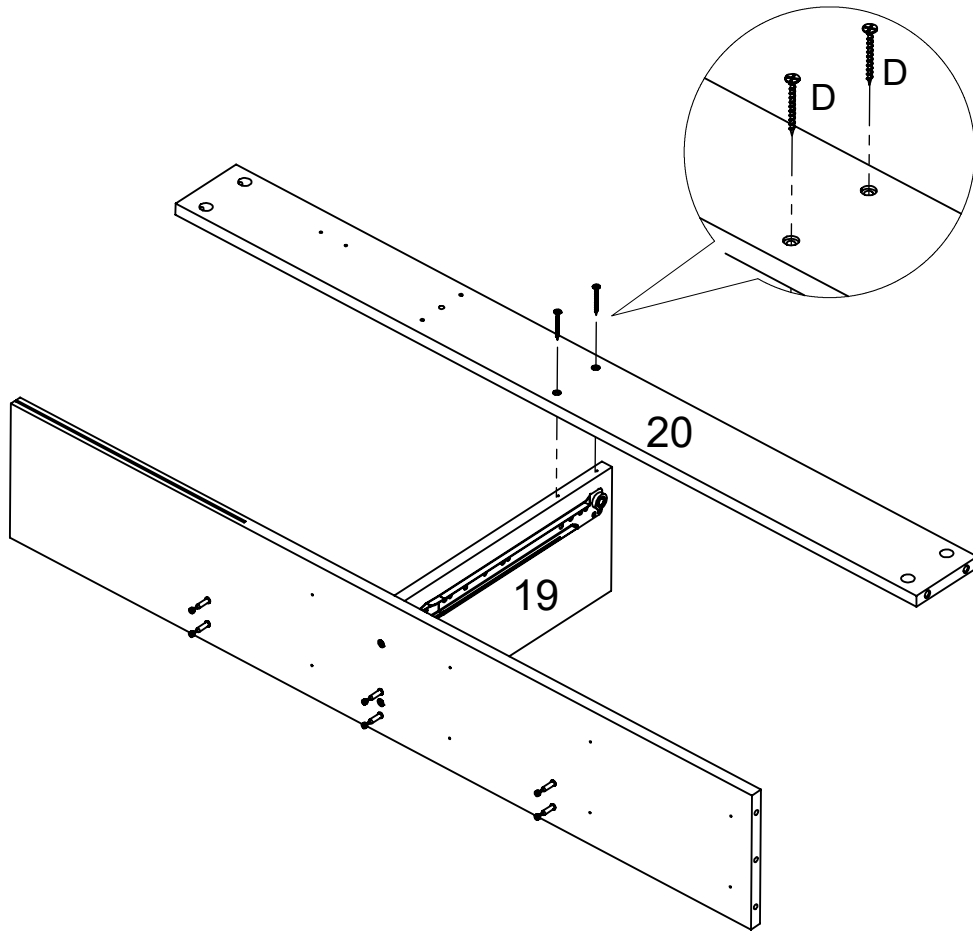

## Step 16

A		6 pcs
---	---	-------

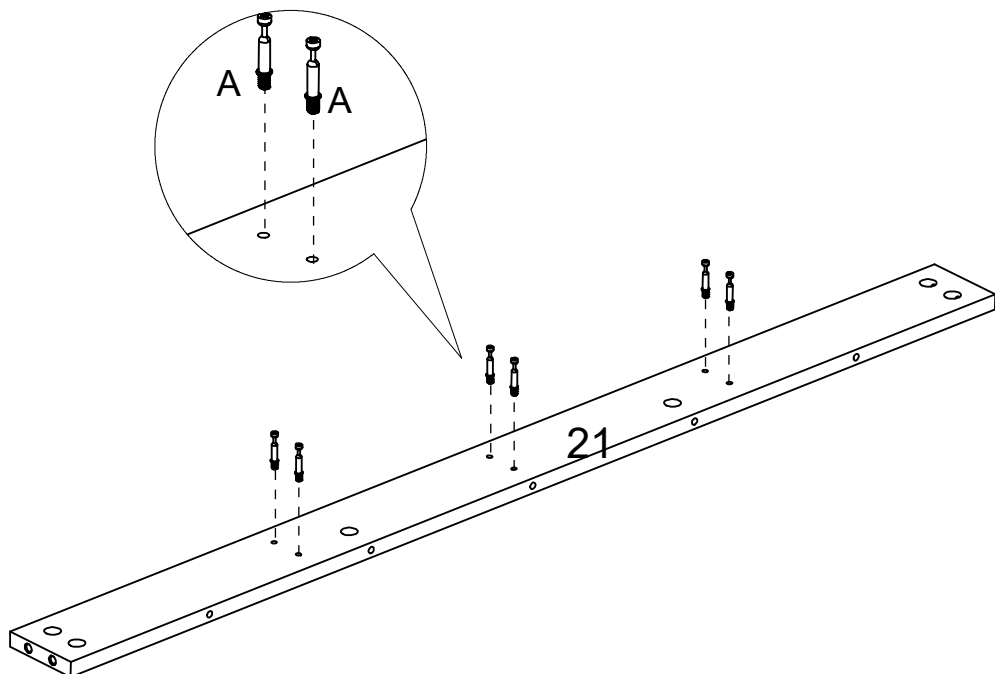

## Step 17

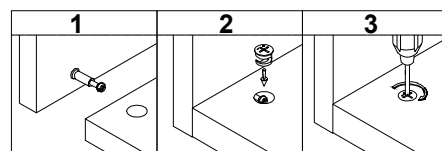
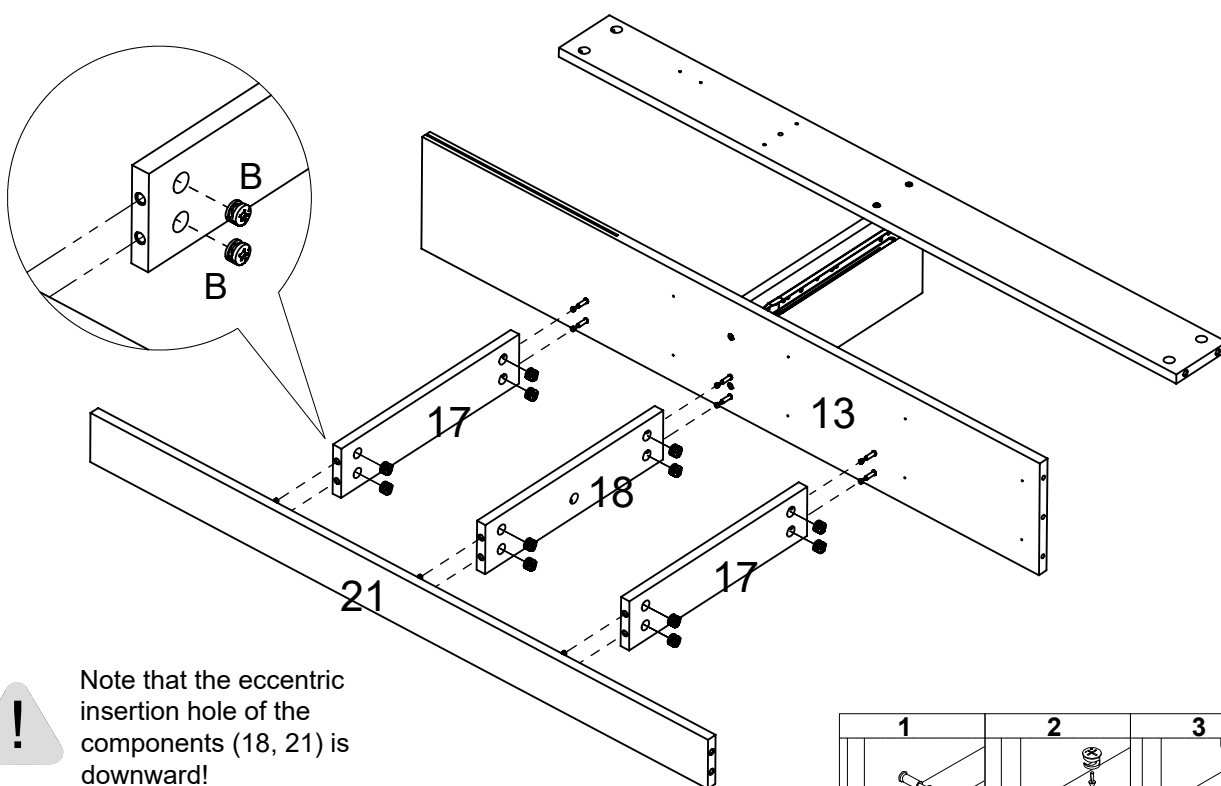

## Step 18

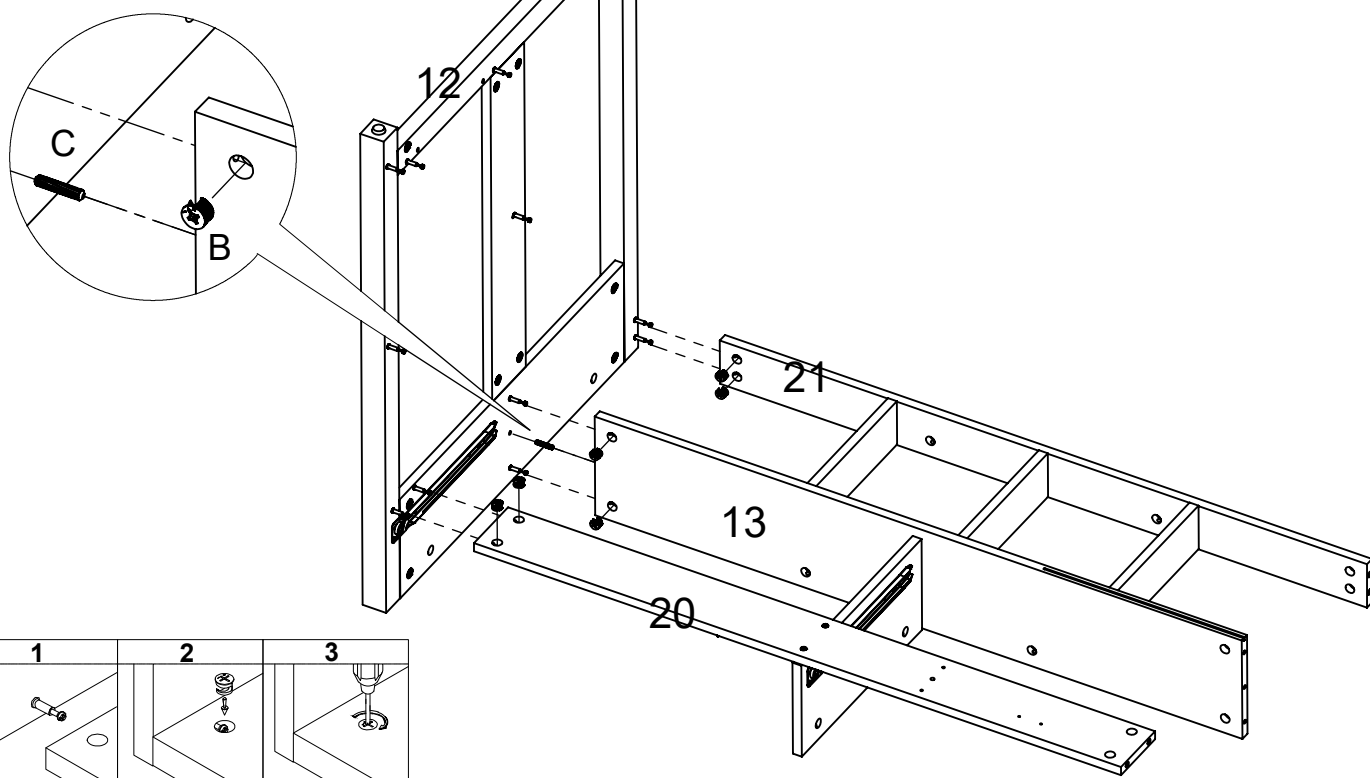

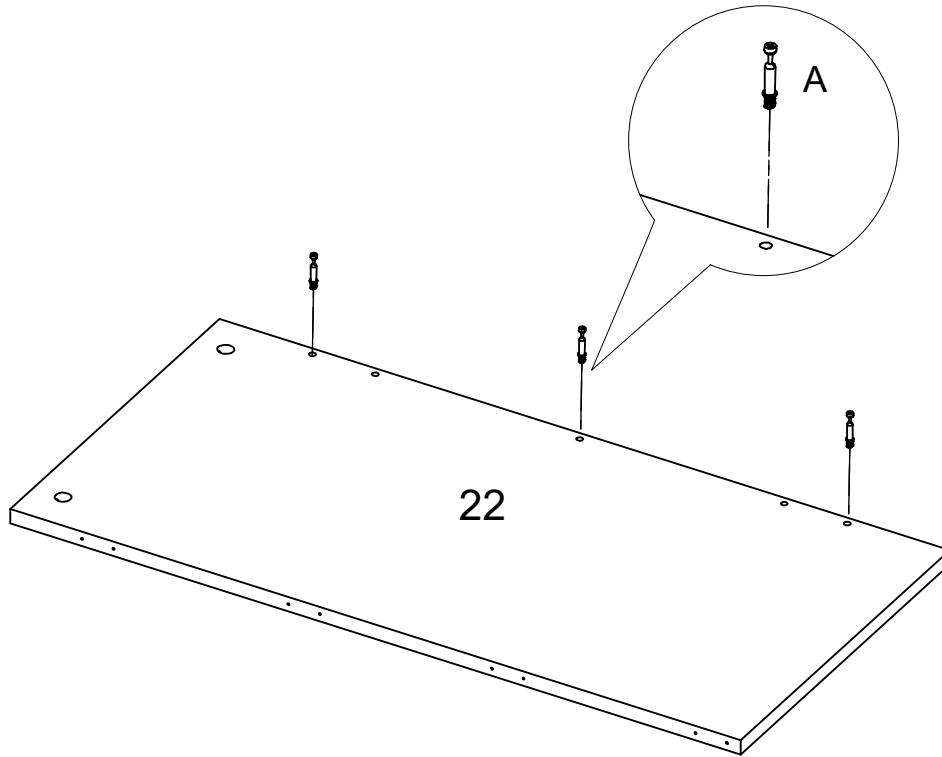

## Step 19

A		3 pcs
---	--	-------



## Step 20

B		3 pcs
C		2 pcs

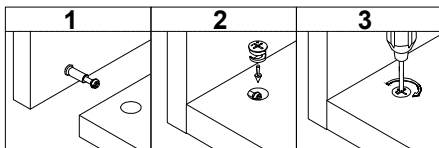
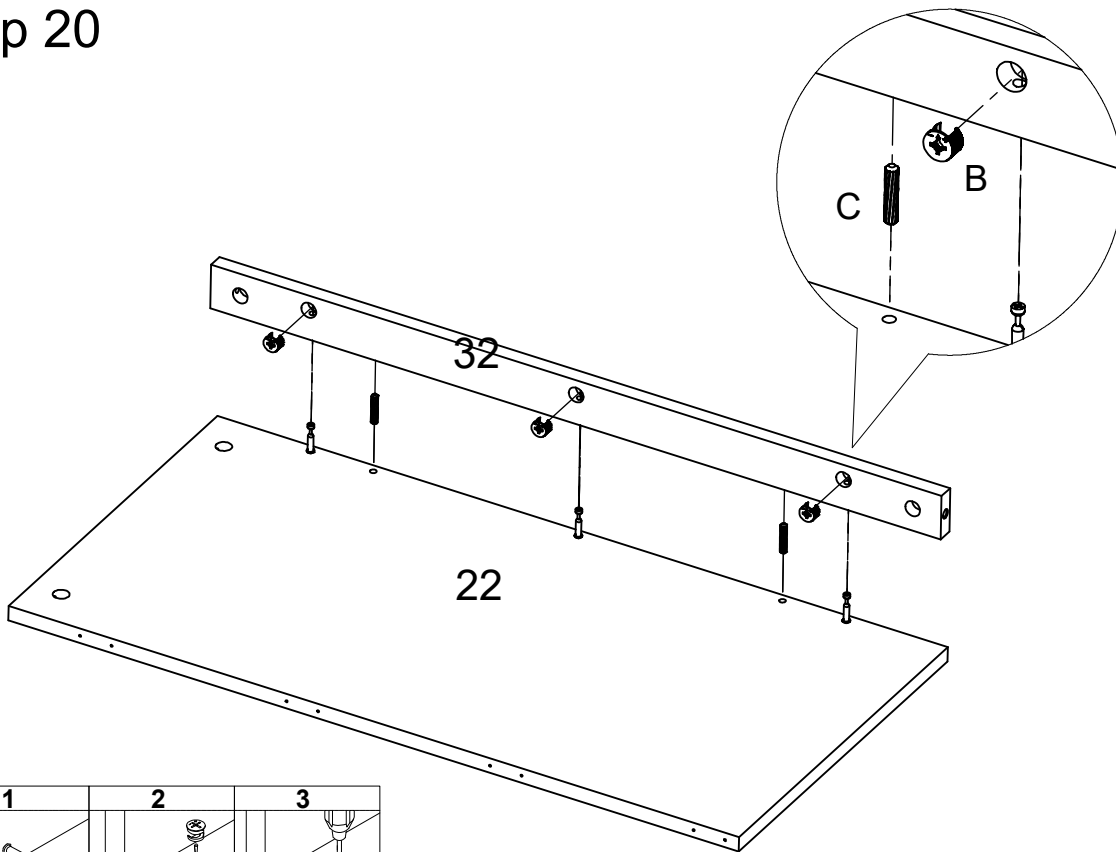

## Step 21

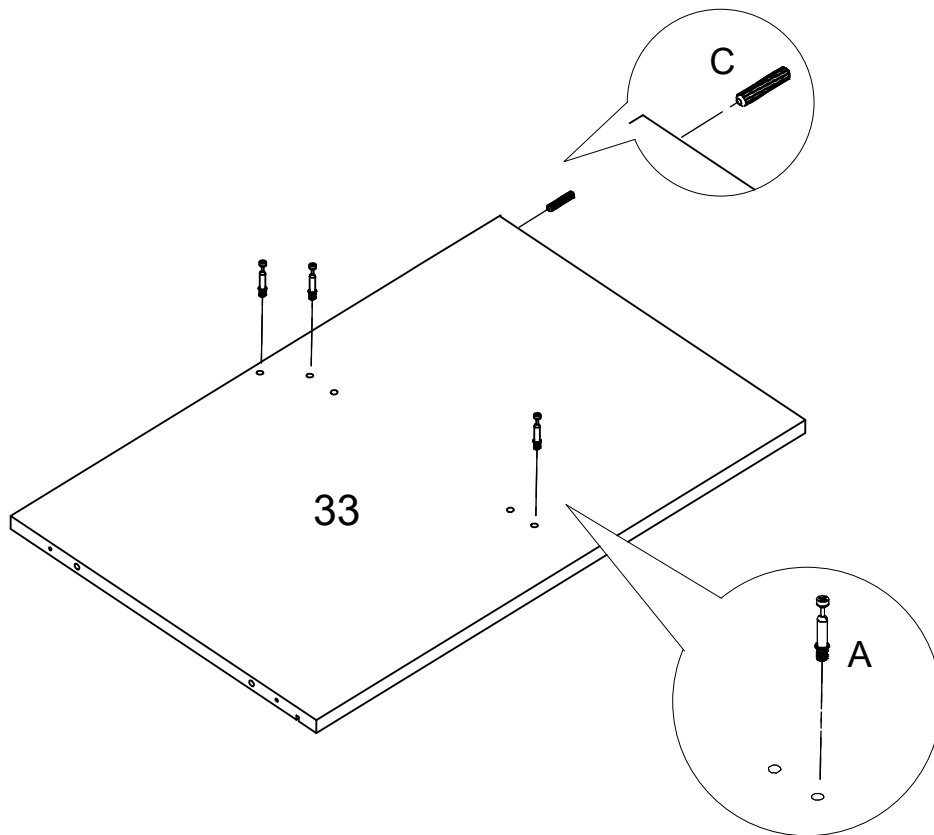

A		3 pcs
C		1 pc

## Step 22

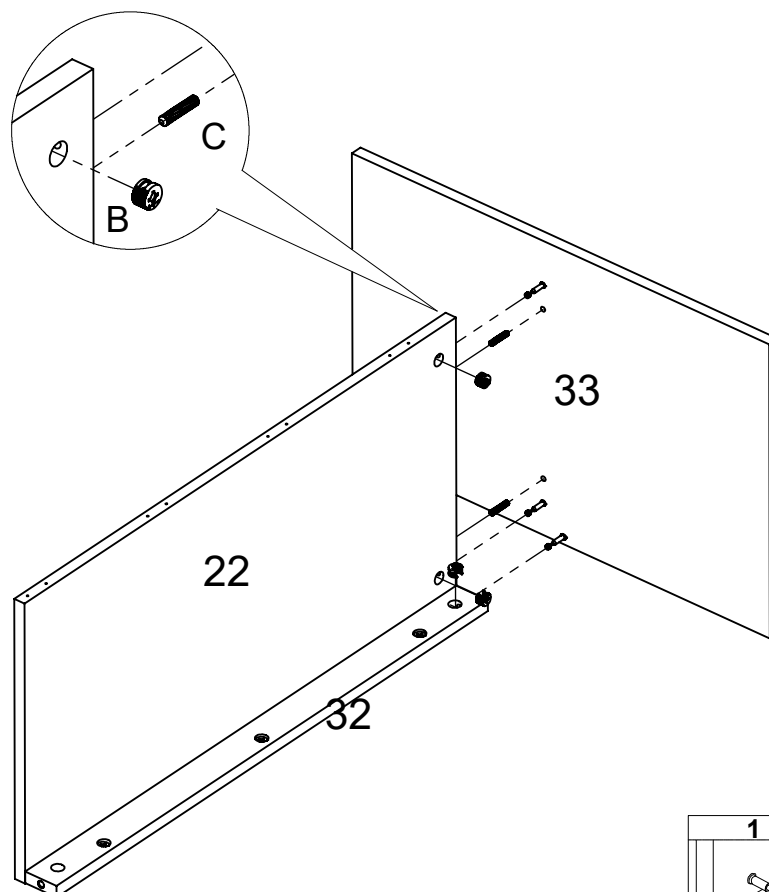

B		3 pcs
C		2 pcs

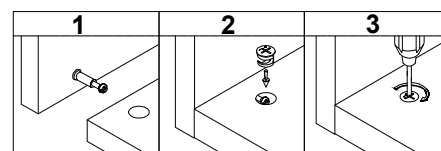

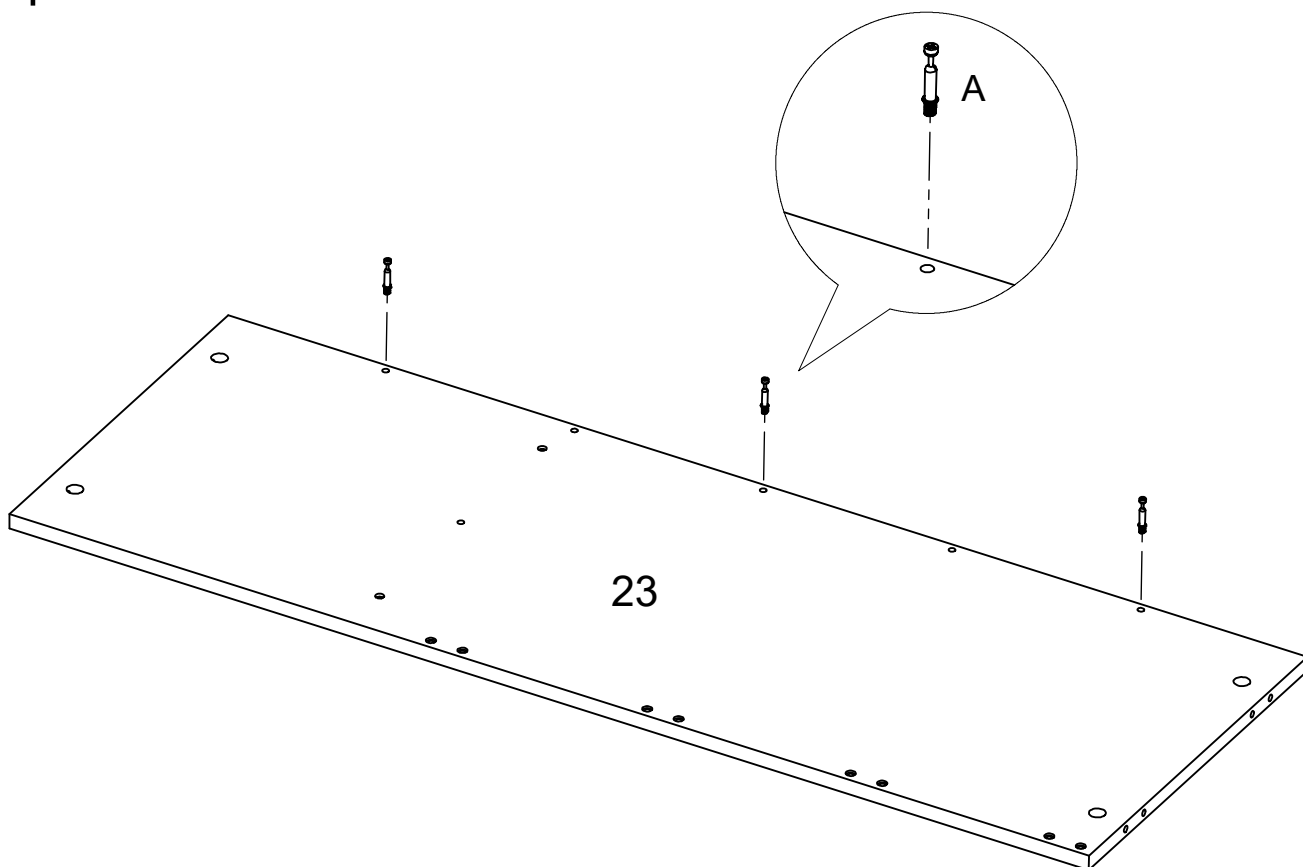

## Step 23

A		3 pcs
---	--	-------



## Step 24

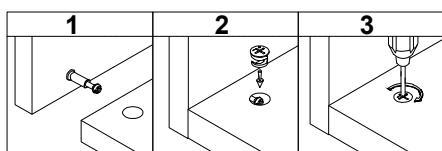
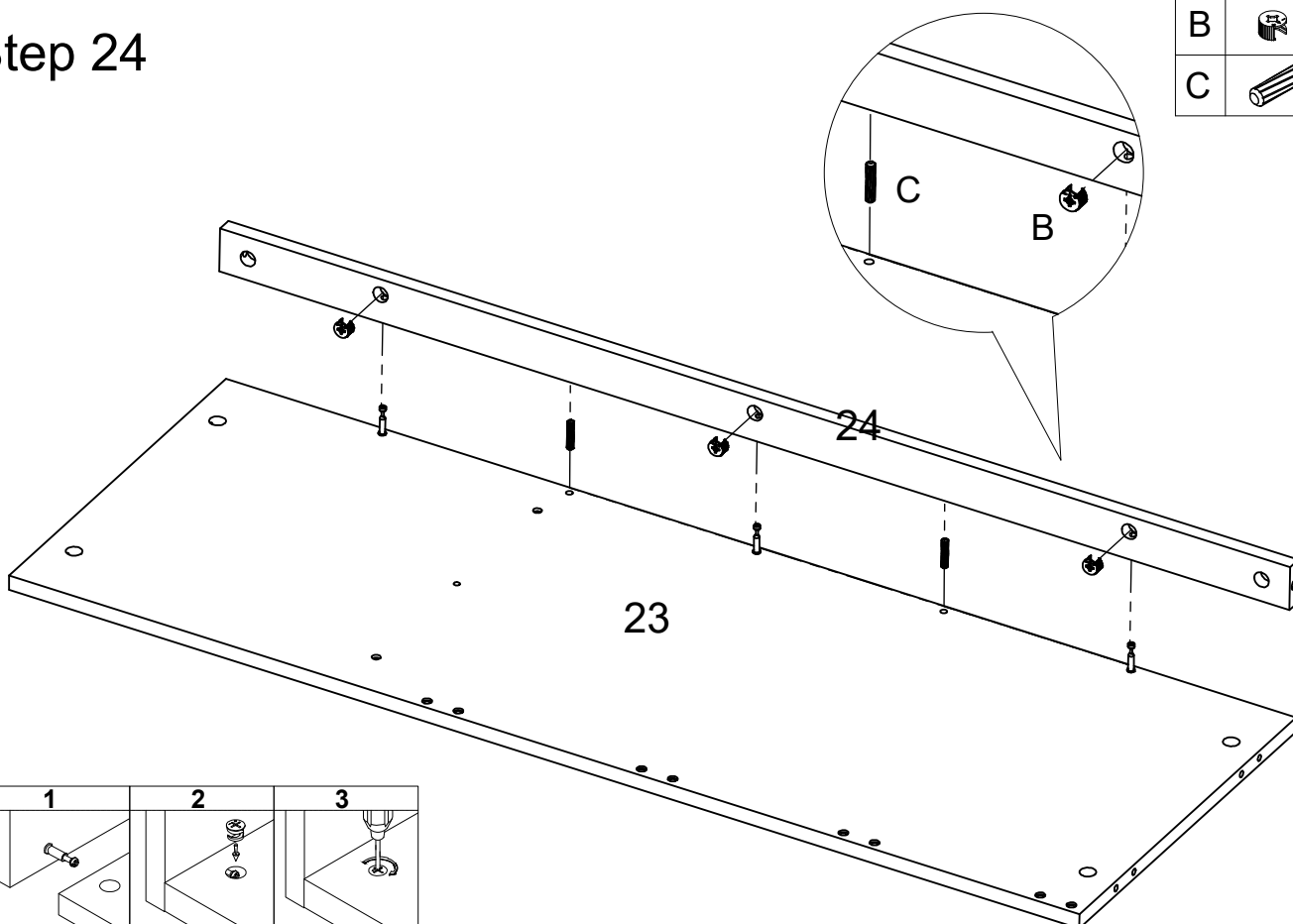

B		3 pcs
C		2 pcs



# PRODUCT ASSEMBLY

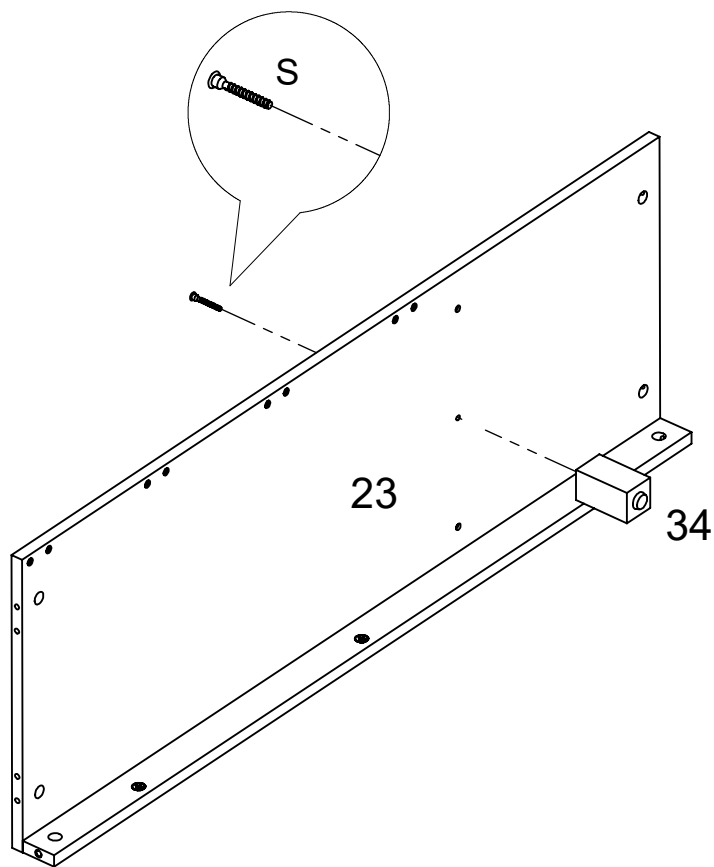
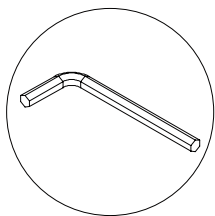

## Step 25

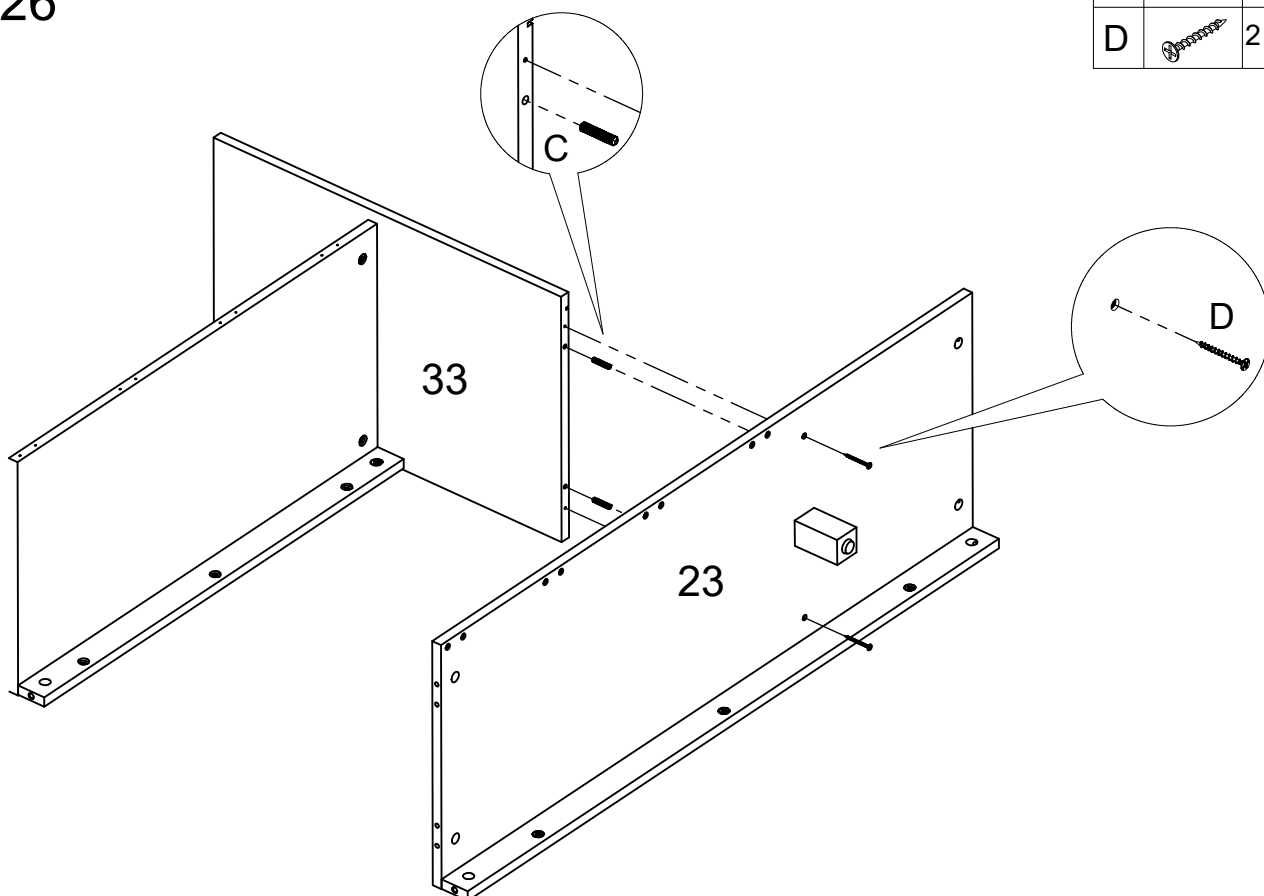

S		1 pc
		1 pc

## Step 26



C		2 pcs
D		2 pcs

# PRODUCT ASSEMBLY

## Step 27

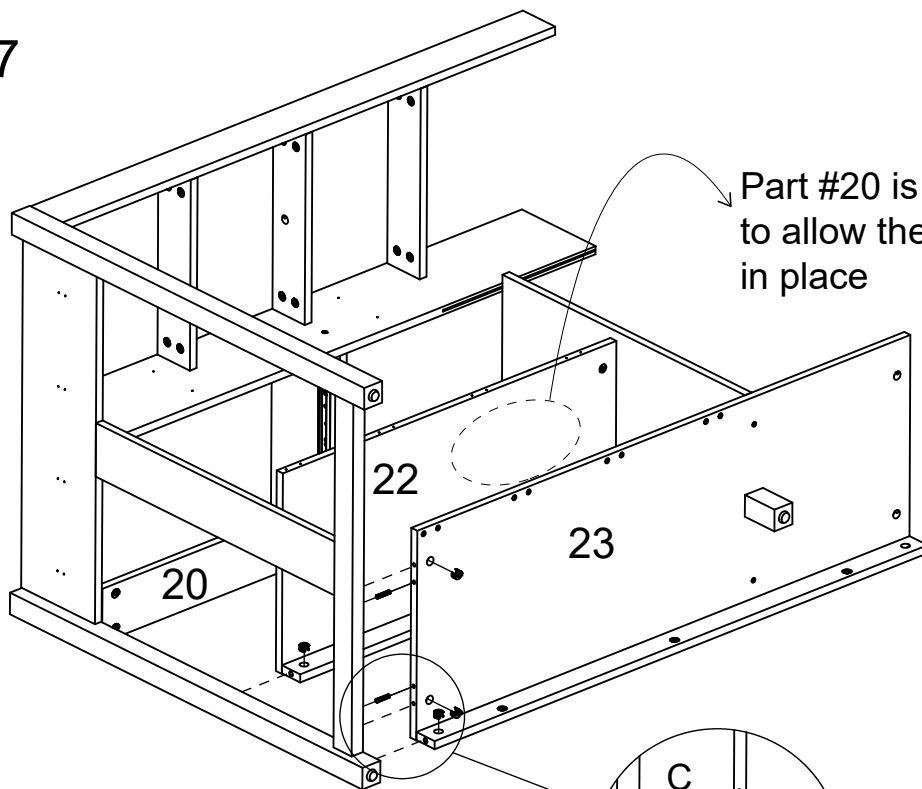

B		4 pcs
C		2 pcs

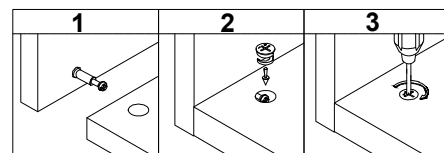
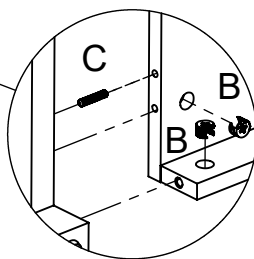

## Step 28

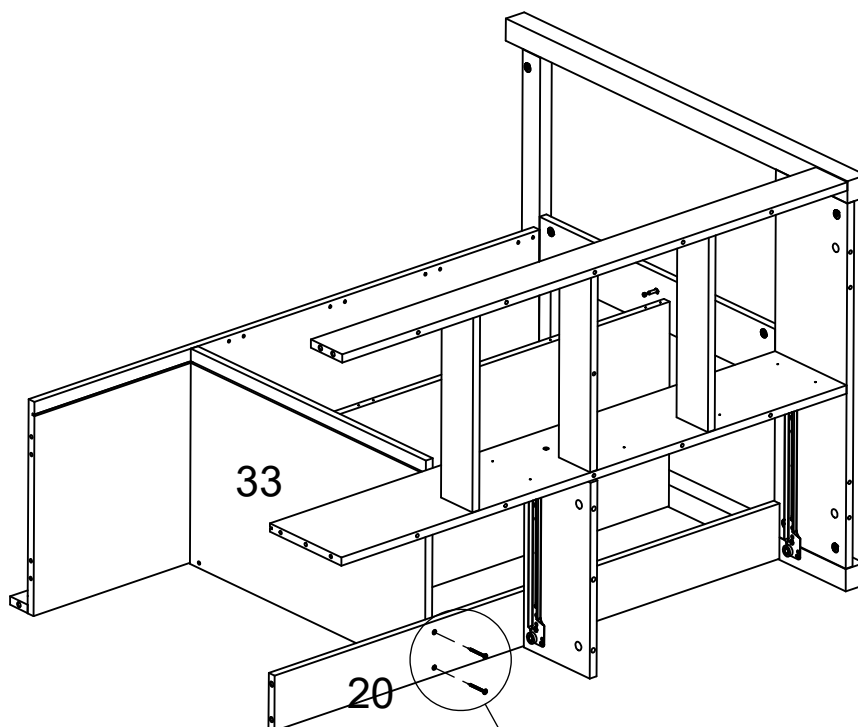

D		2 pcs
---	--	-------

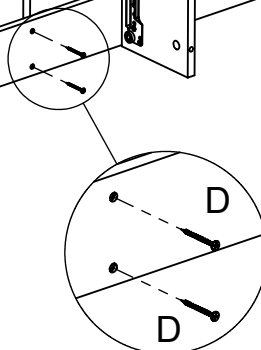

B



1 pc

## Step 29

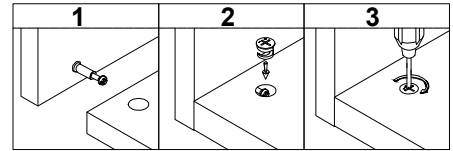
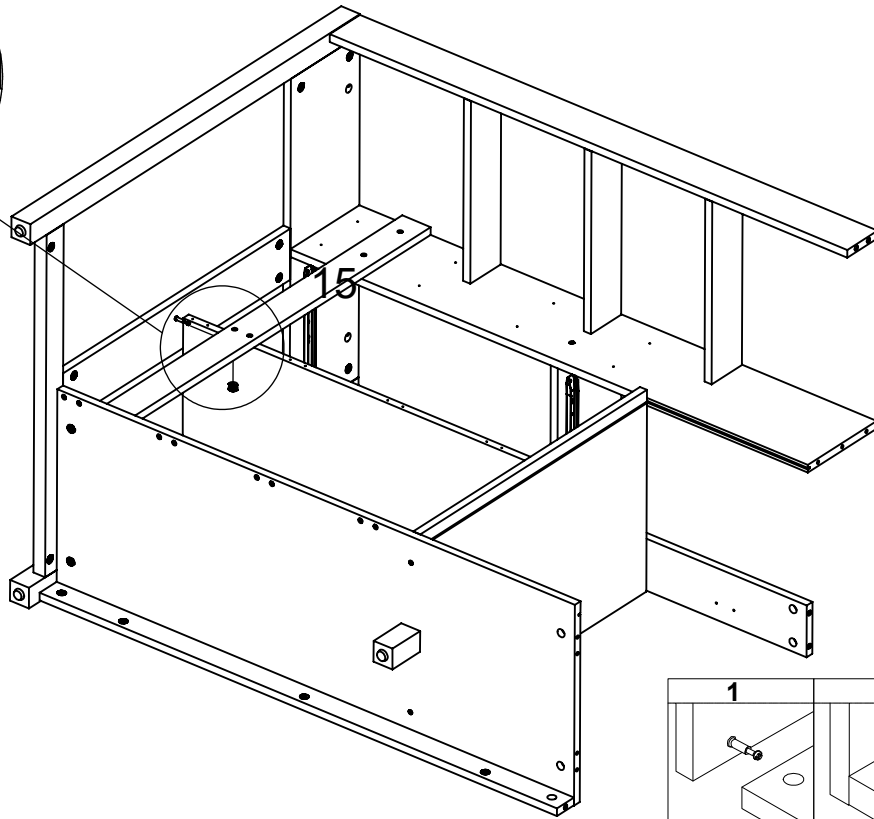
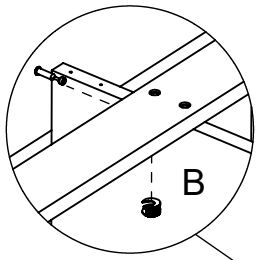

## Step 30

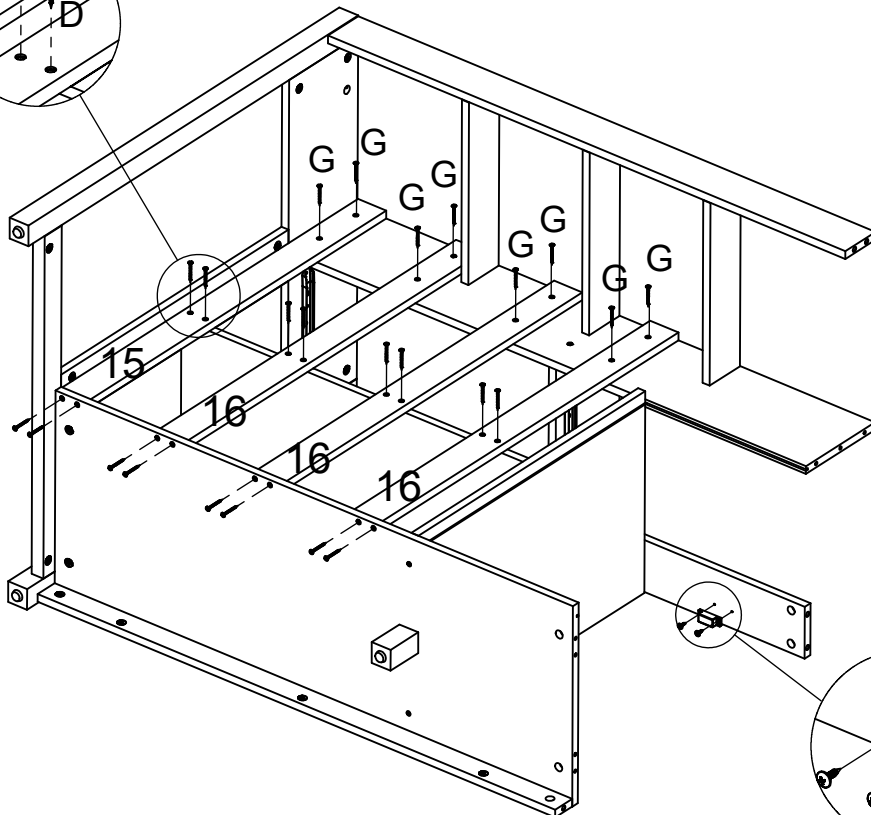
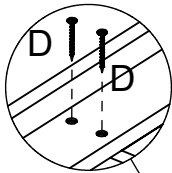

D		16 pcs
G		8 pcs
K		1 set

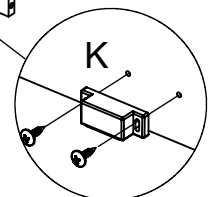

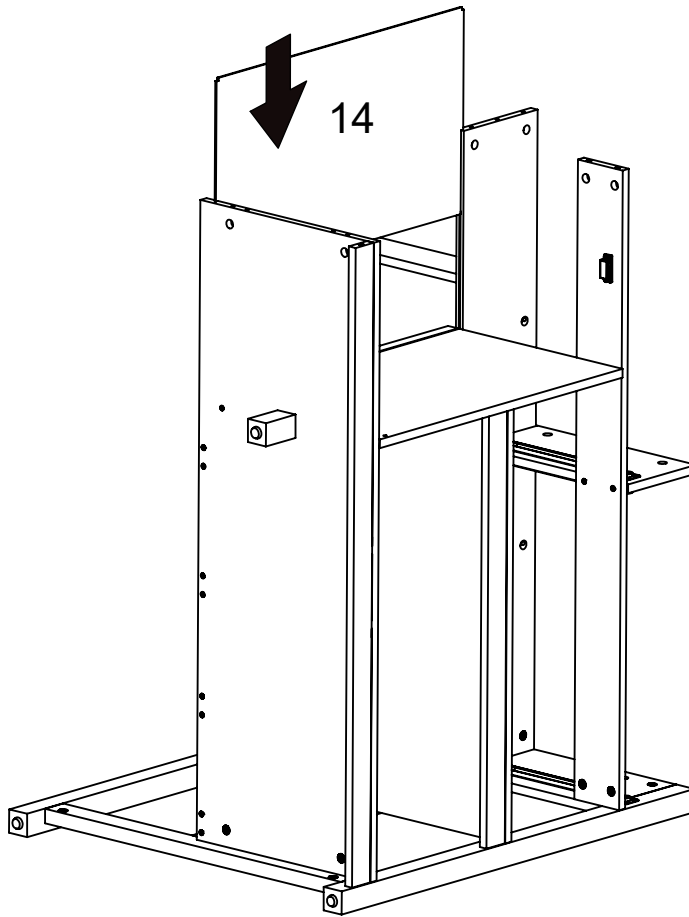

## Step 31

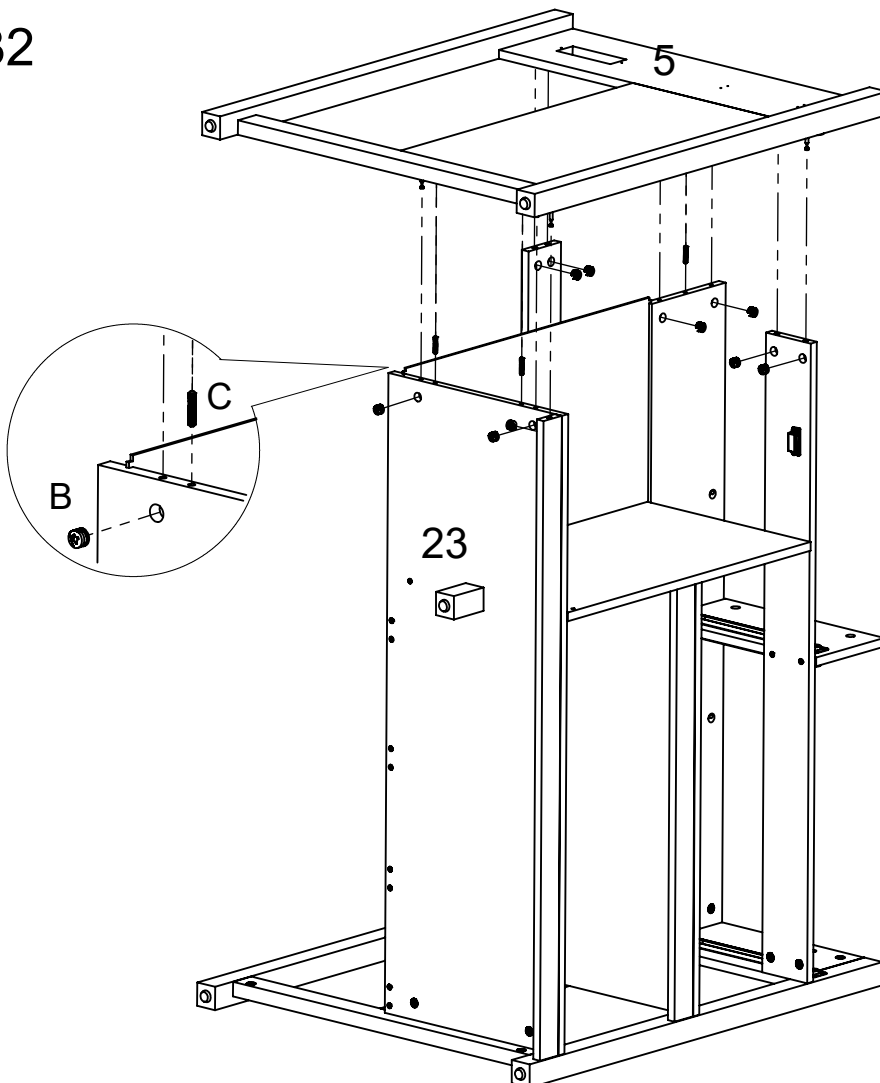

## Step 32





B		9 pcs
C		3 pcs

## Step 33

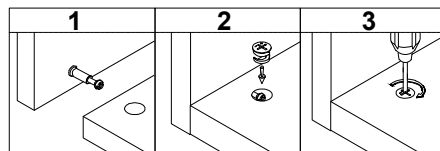
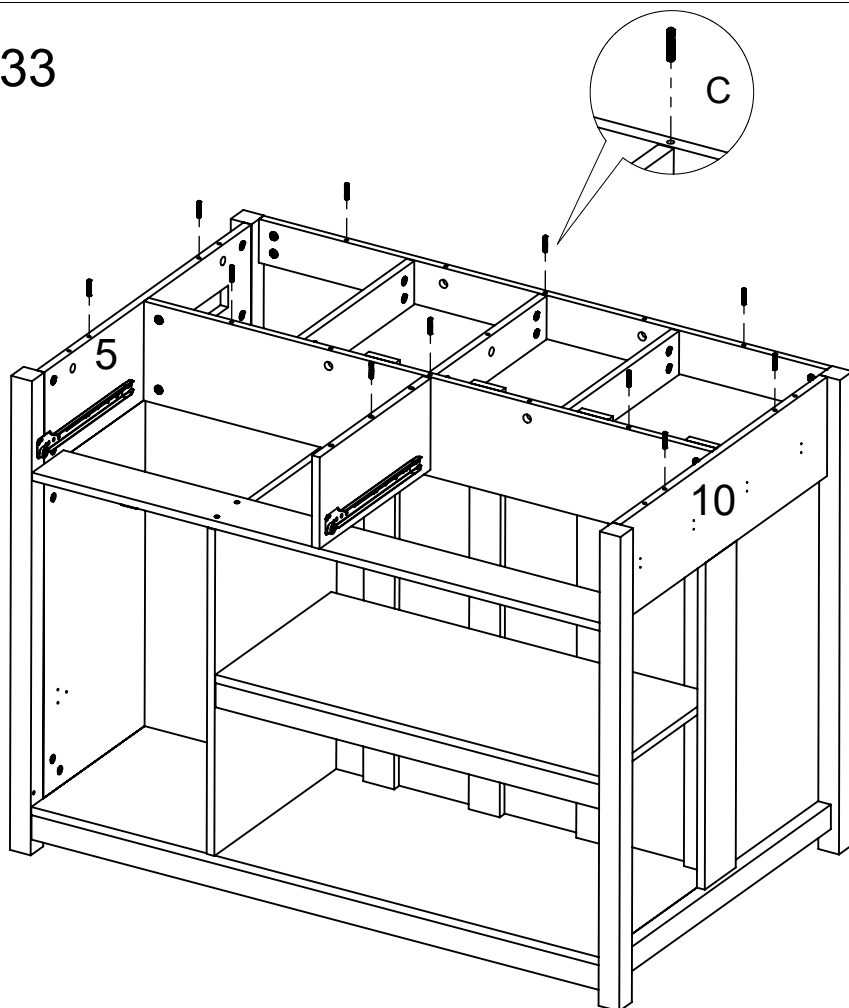
C		11 pcs
---	--	--------



## Step 34

A		2 pcs
B		2 pcs
J		4 pcs

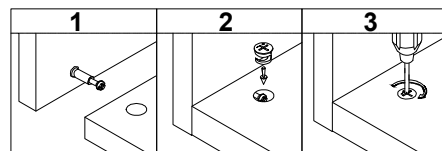
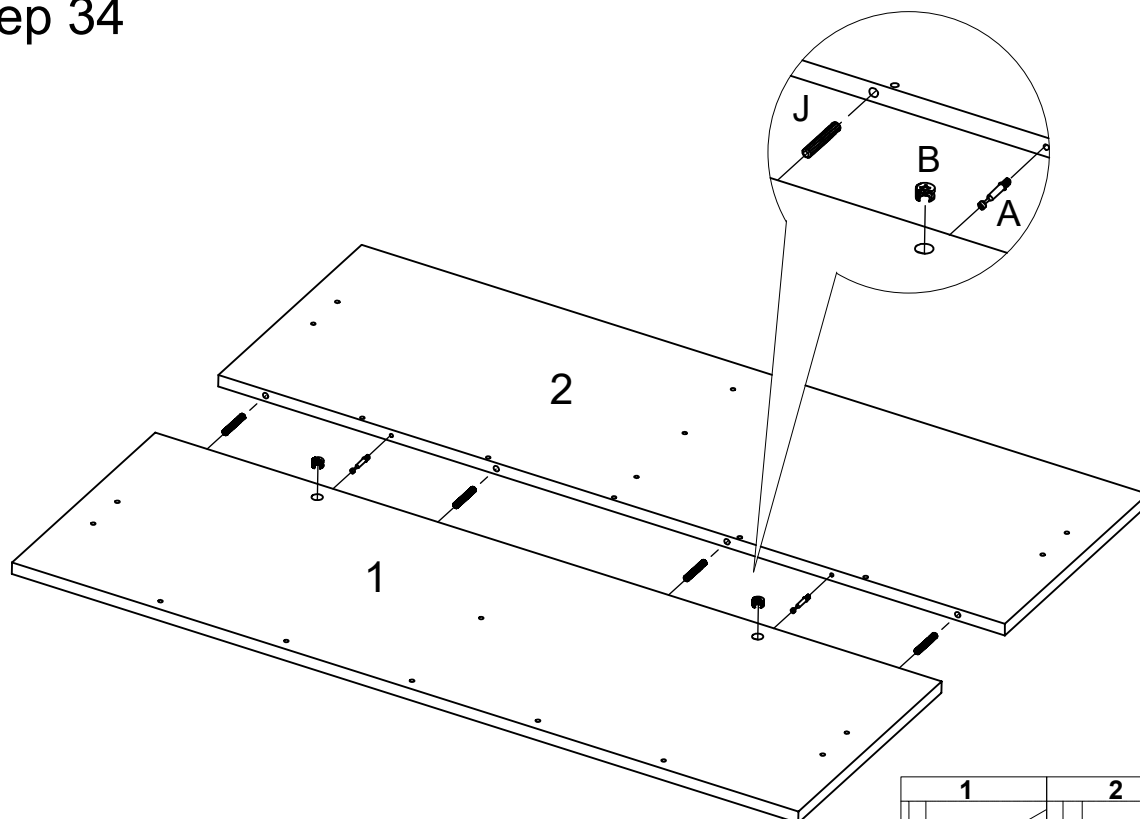

## Step 35

A  11 pcs

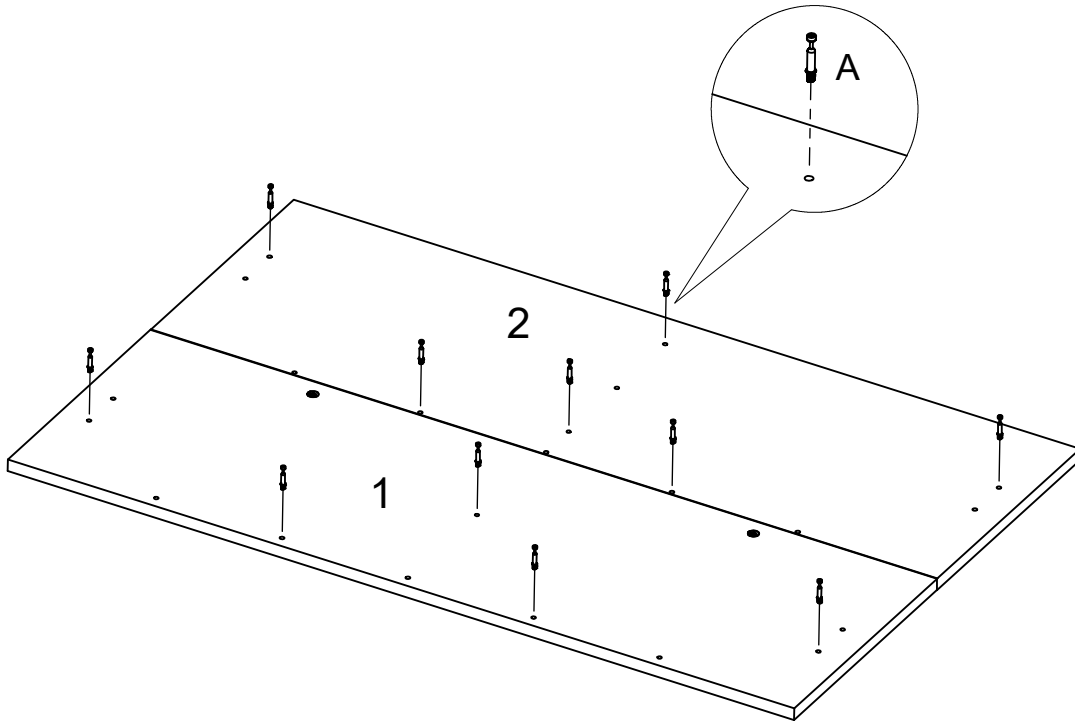

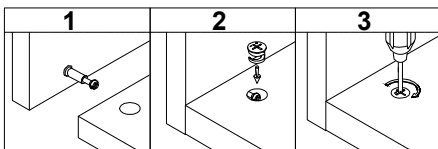
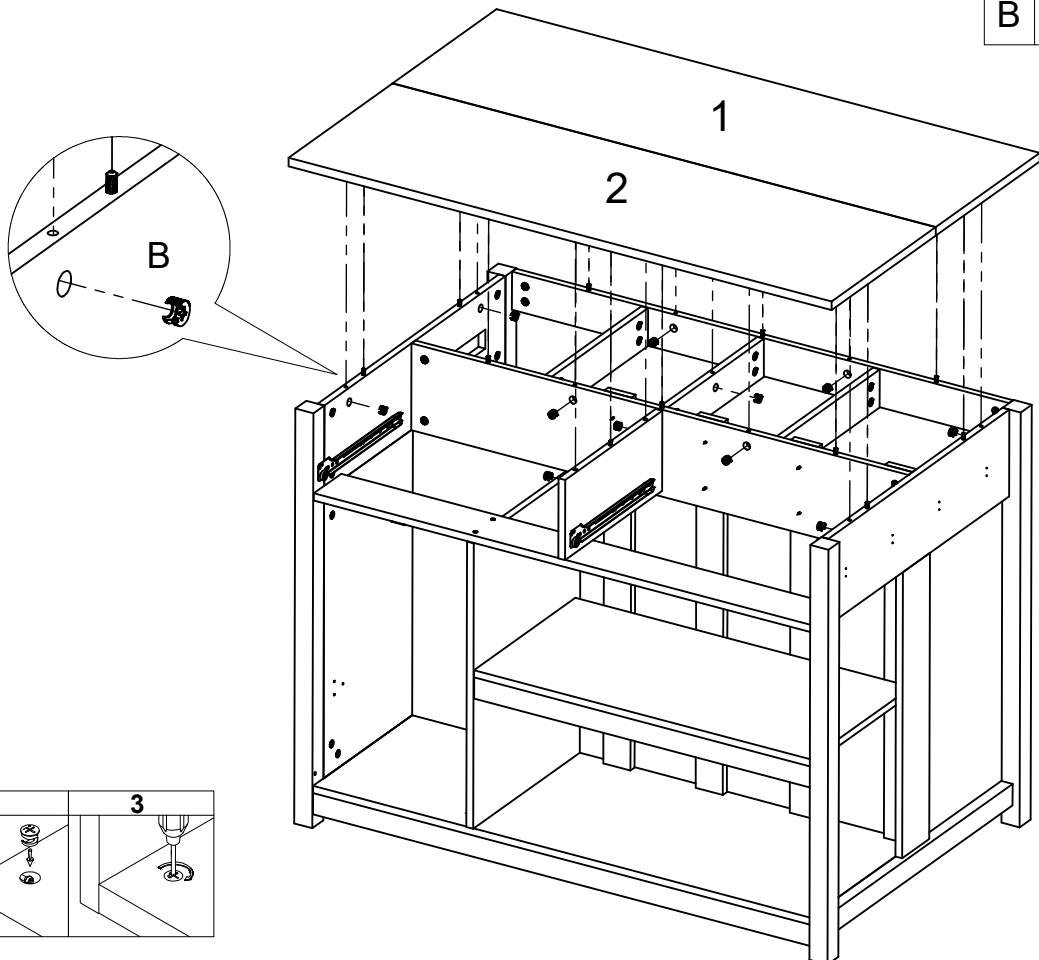

## Step 36

B  11 pcs





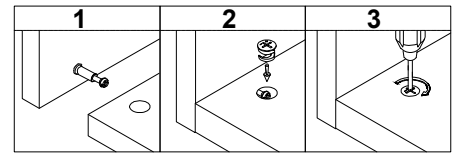
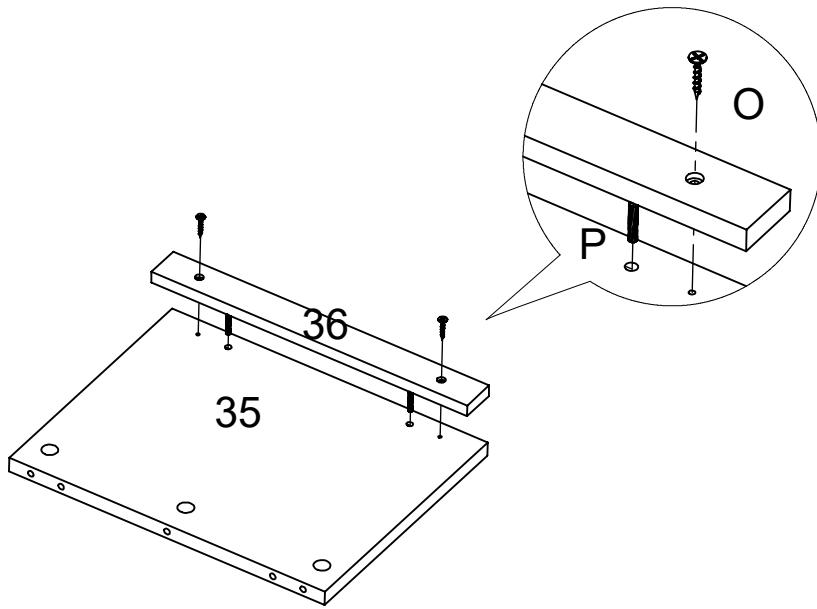

## Step 37

O		2 pcs
P		2 pcs



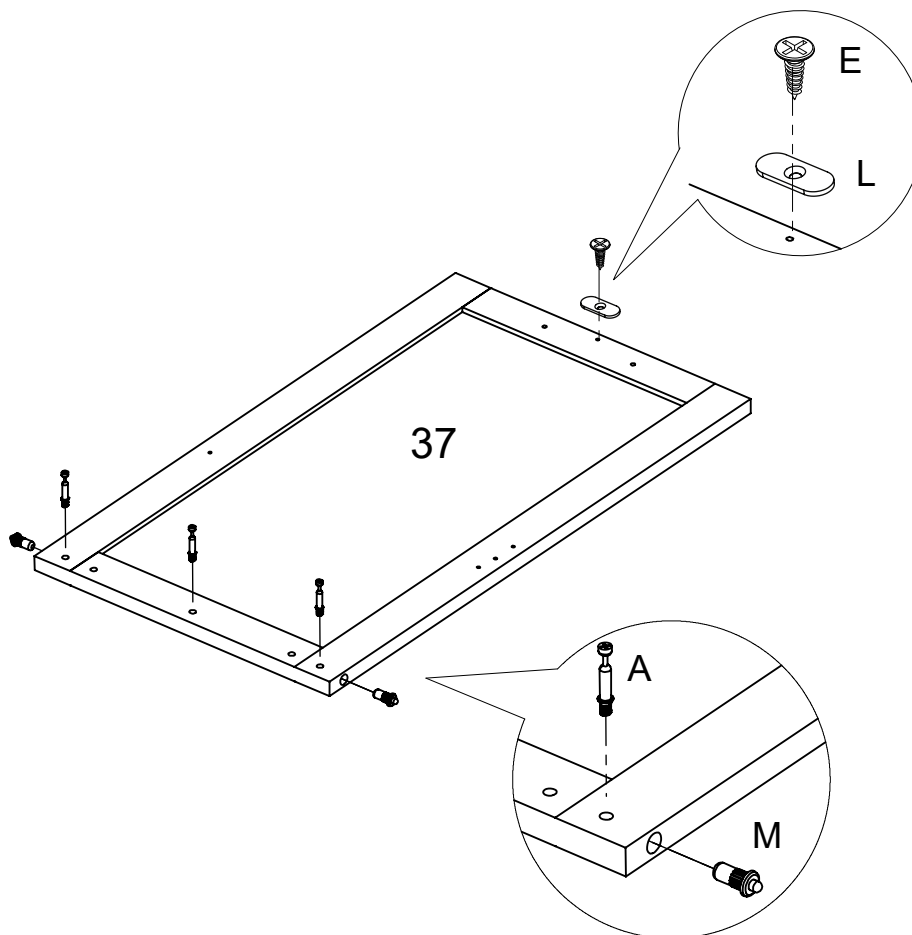

## Step 38

A		3 pcs
E		1 pc
L		1 pc
M		2 pcs



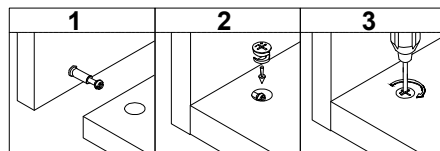
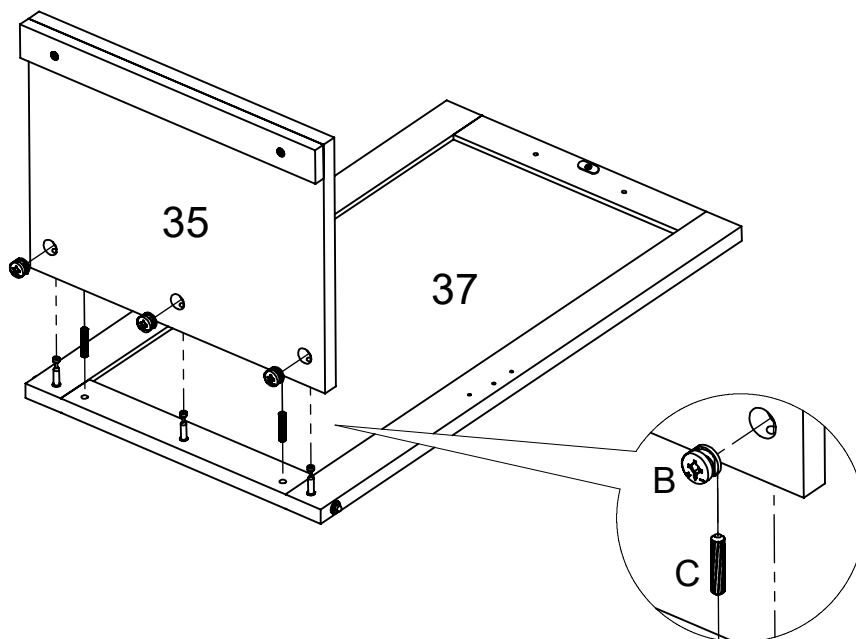

## Step 39

B		3 pcs
C		2 pcs



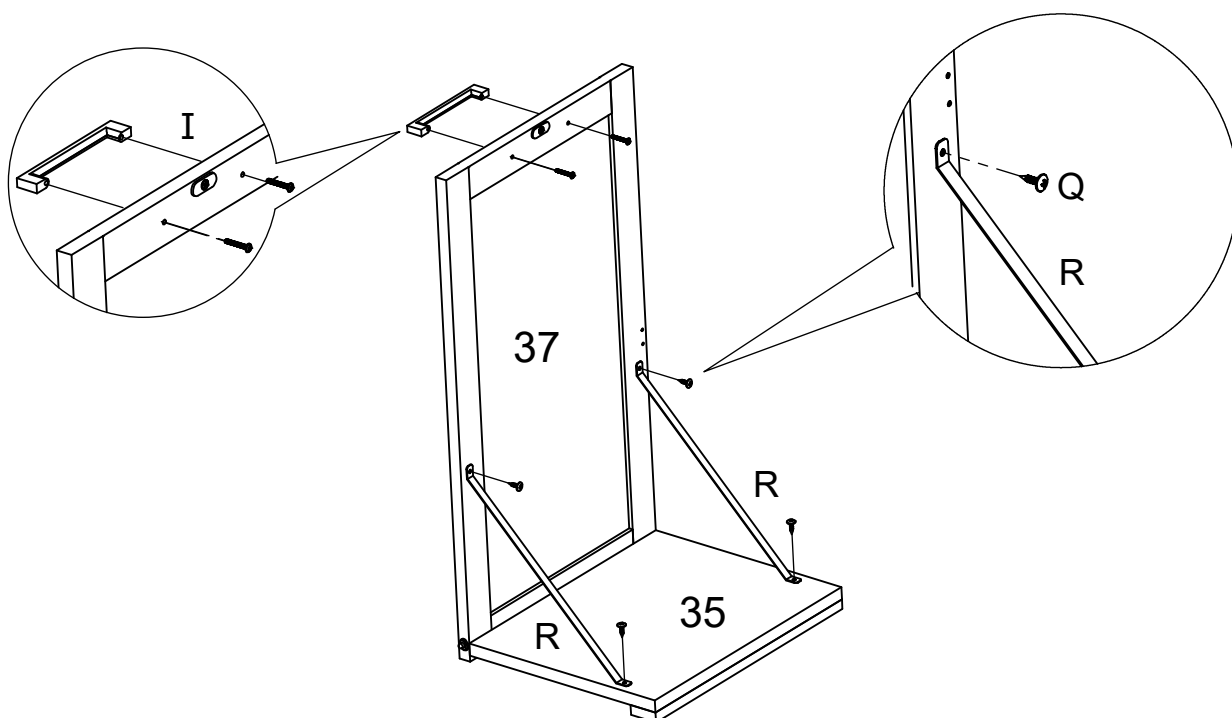

## Step 40

I		1 set
Q		4 pcs
R		2 pcs



## Step 41

E		2 pcs
N		1 pc

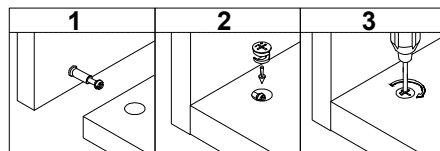
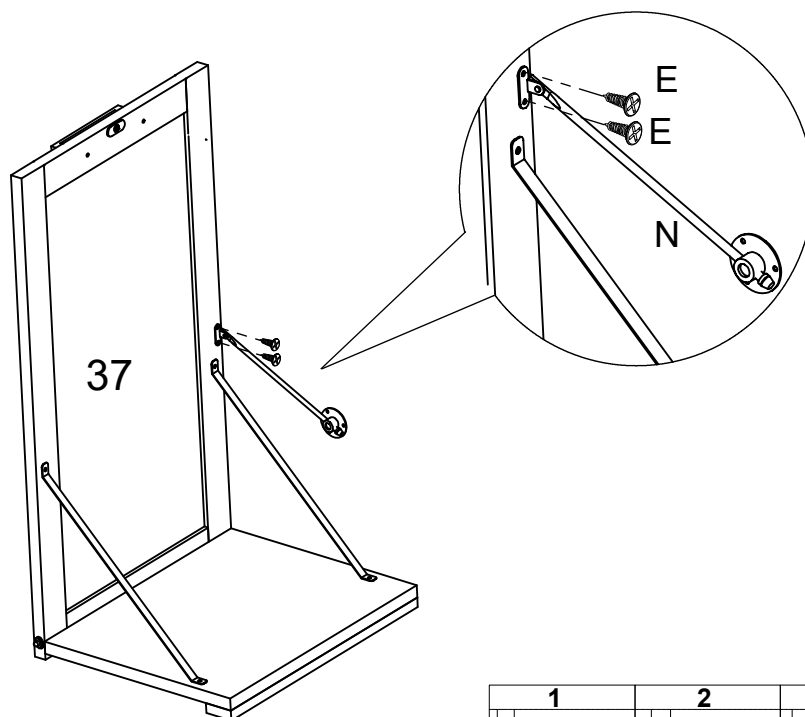

## Step 42

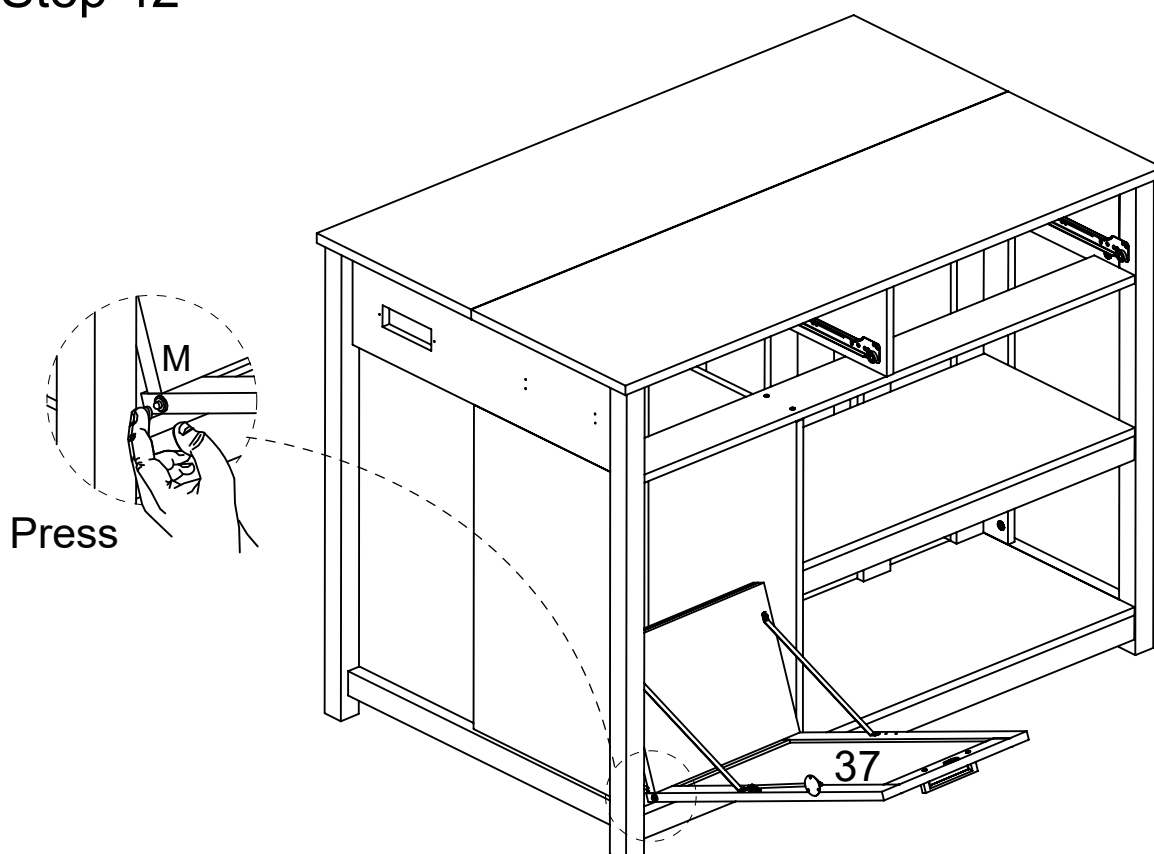

## Step 43

E		3 pcs
---	--	-------

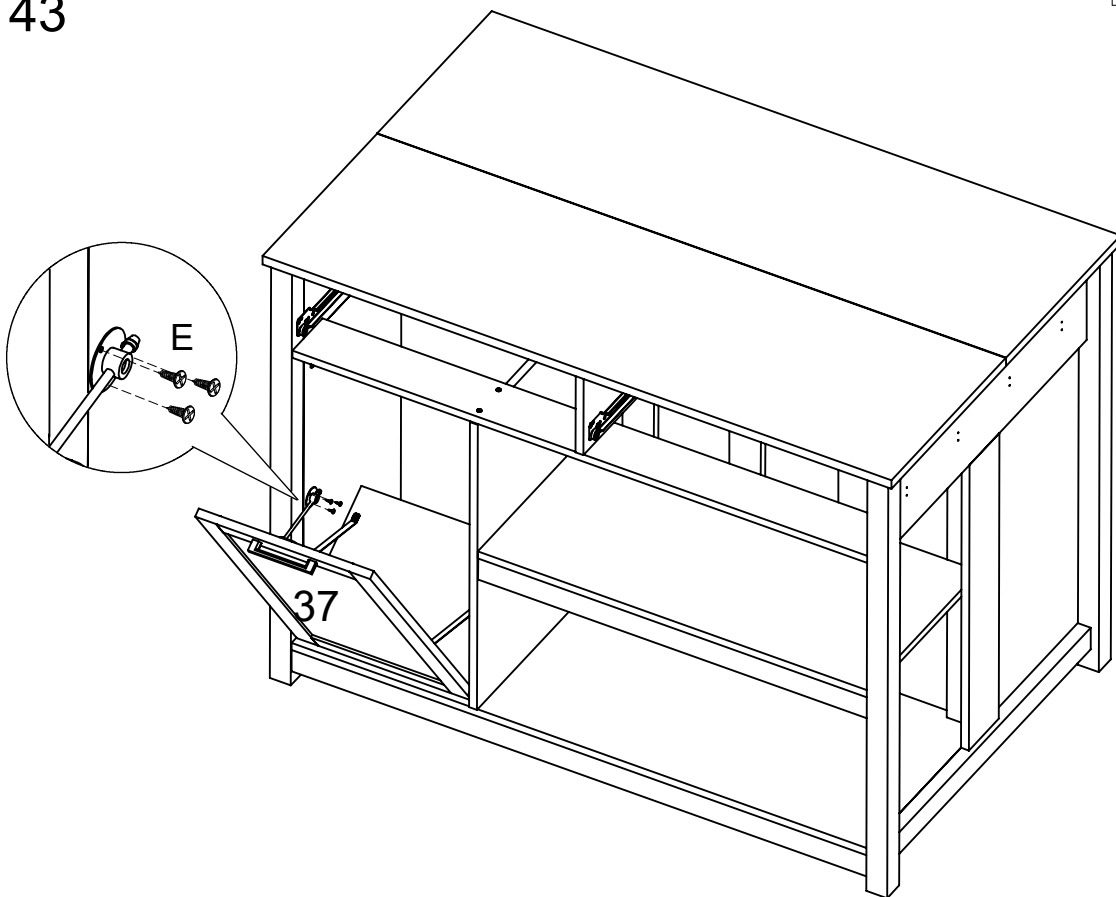

## Step 44

D		10 pcs
---	---	--------

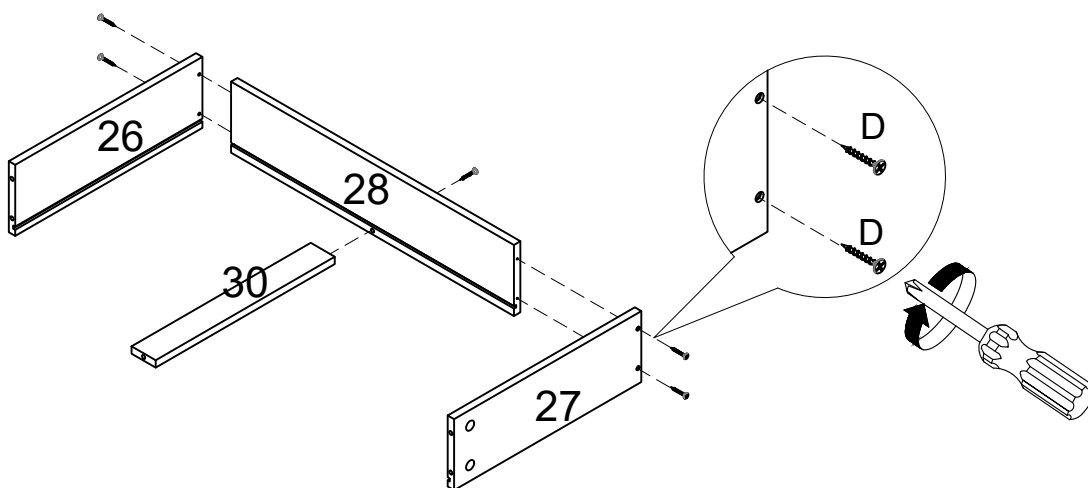

# X 2

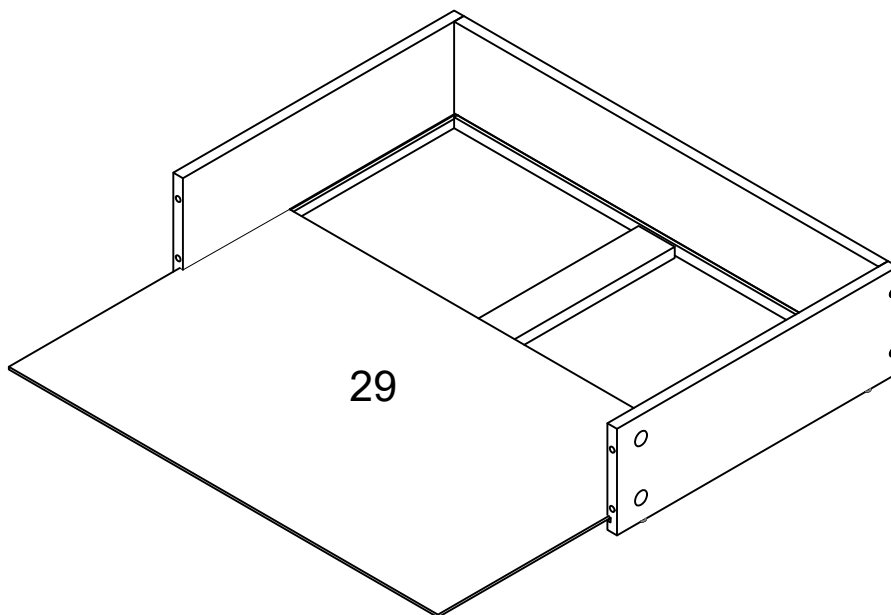

Step 45

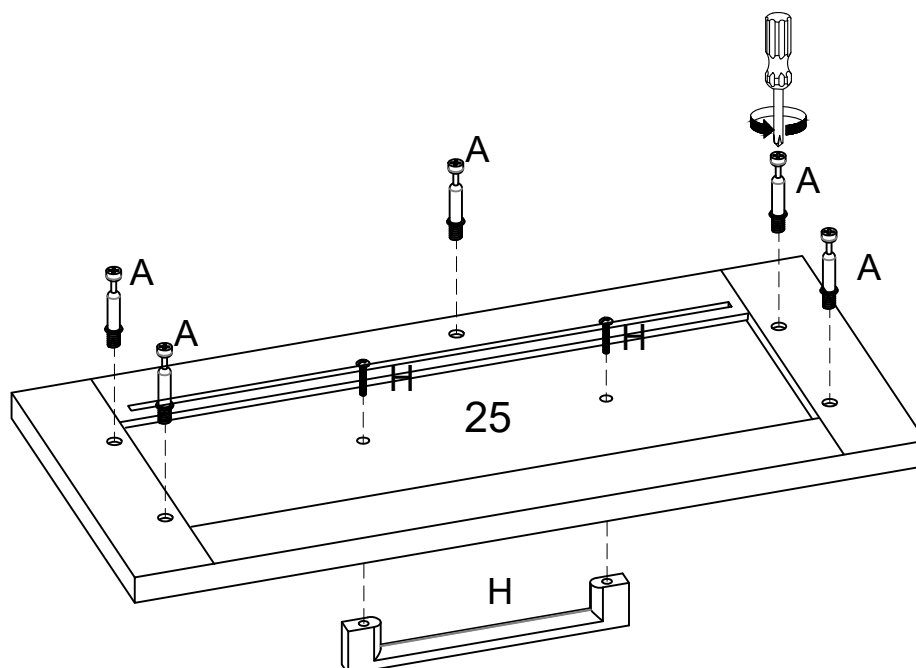

**X 2**

Step 46



A		10 pcs
H		2 sets

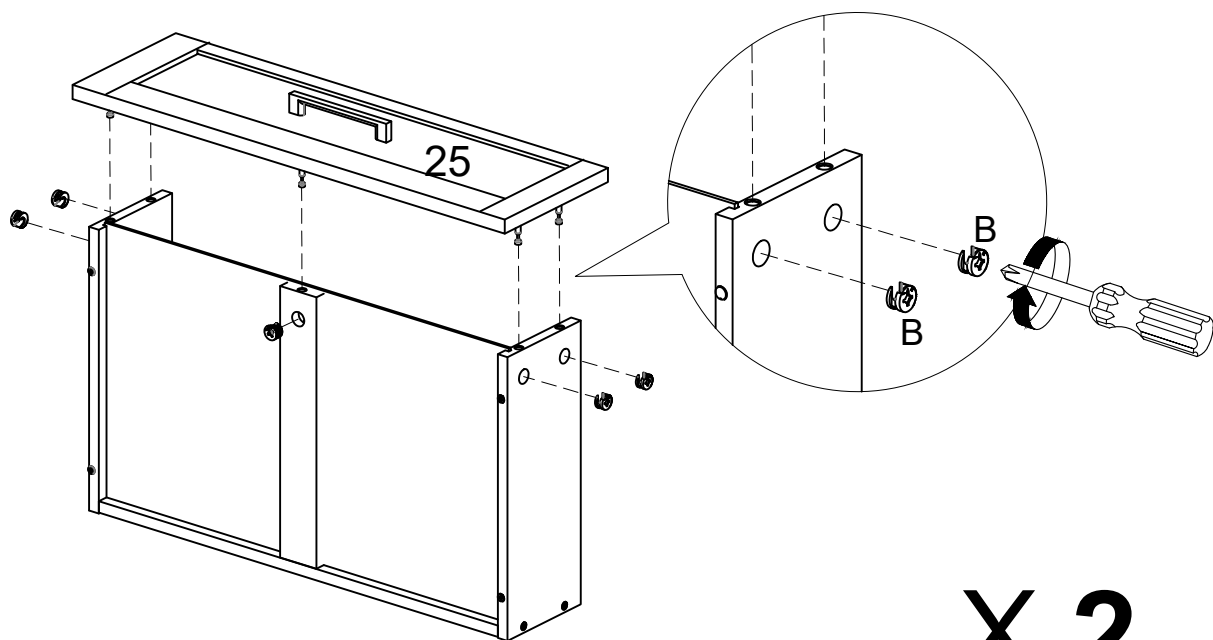

**X 2**

Step 47



**X 2**

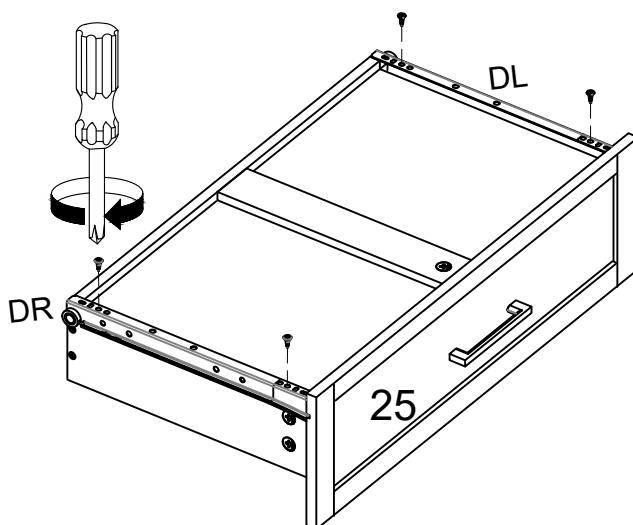
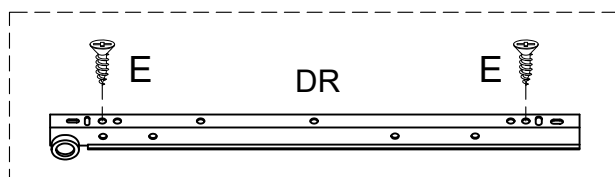
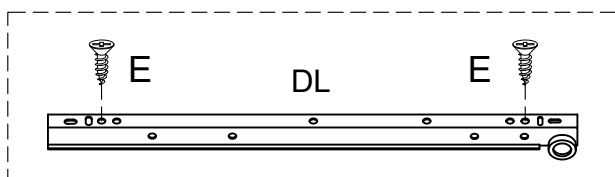

Step 48

E		8 pcs
DR		2 pcs
DL		2 pcs



**X 2**

## Step 49

F		6 pcs
E		14 pcs

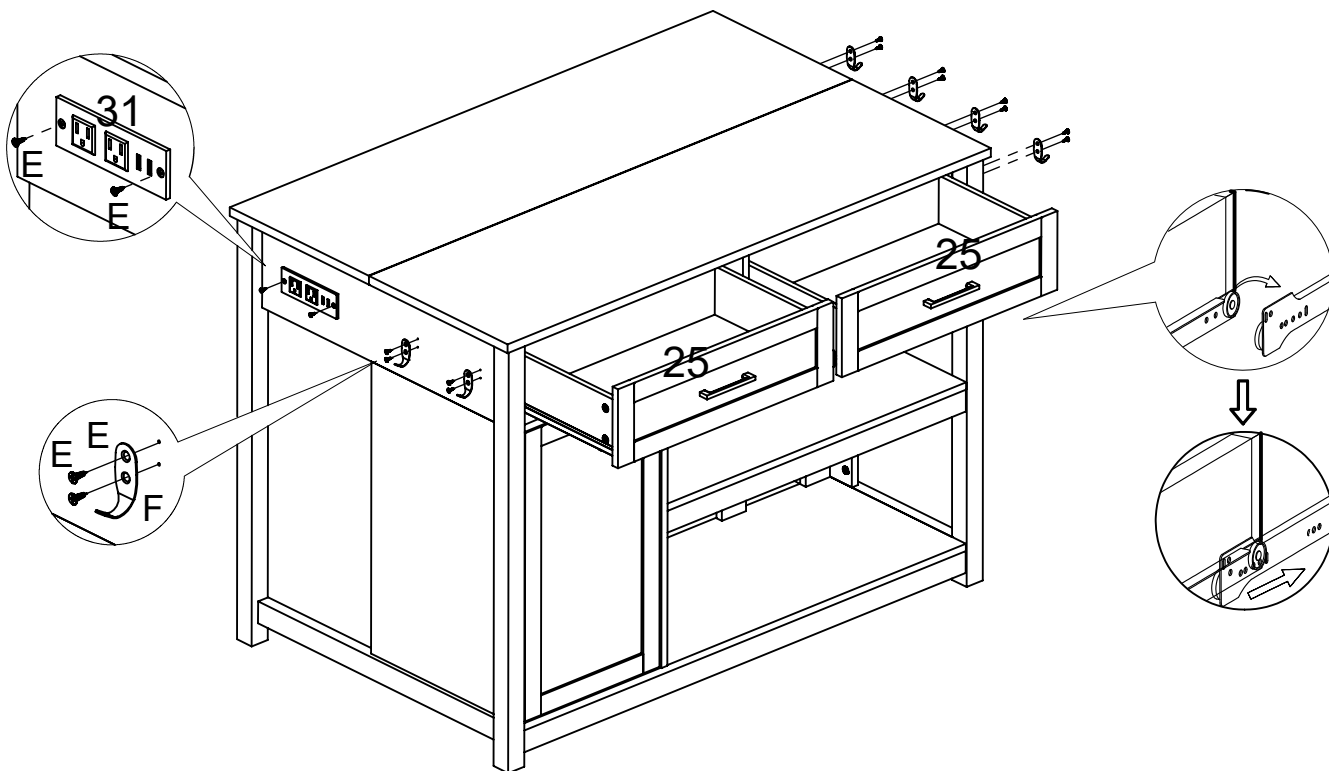

## Step 50

T		16 pcs
---	---	--------

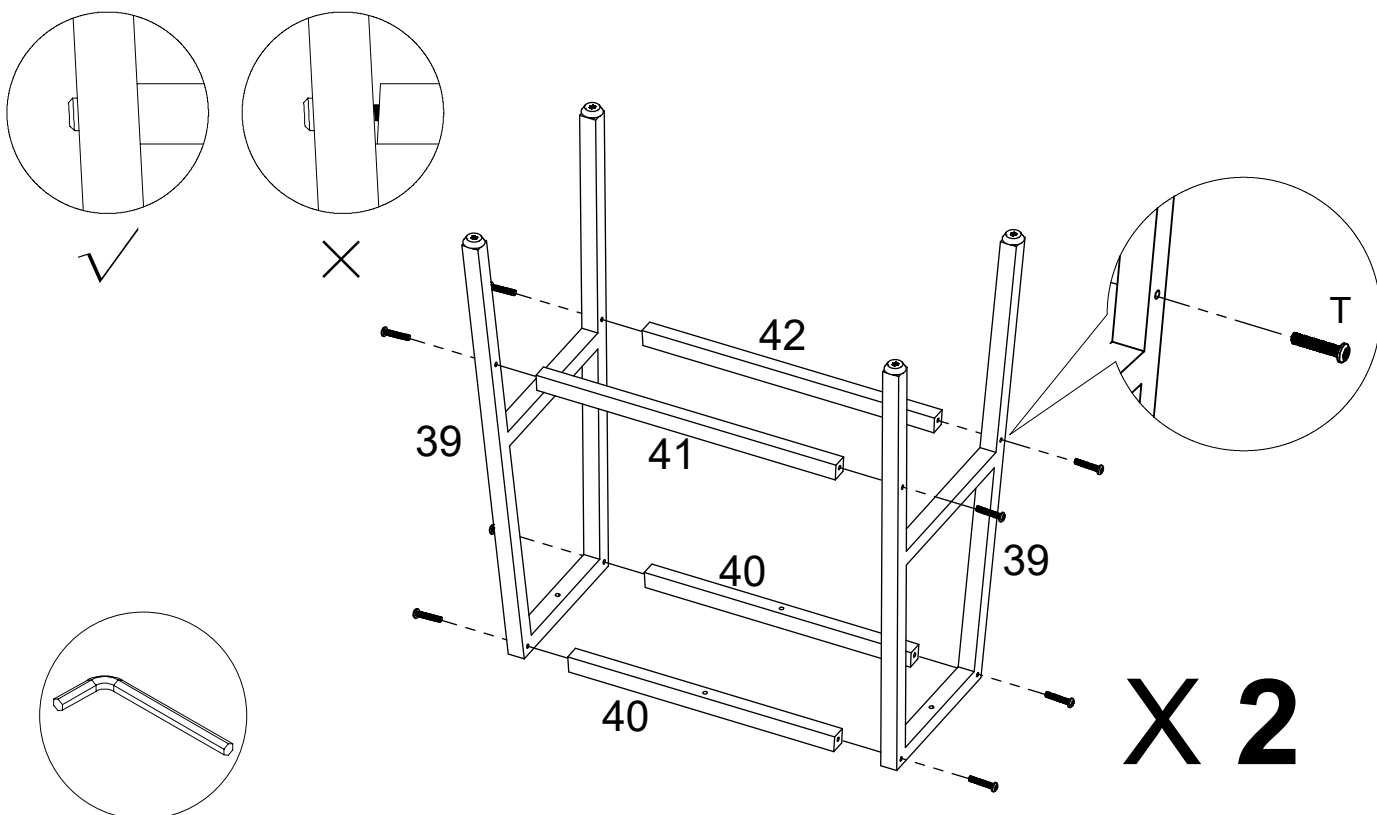

## Step 51

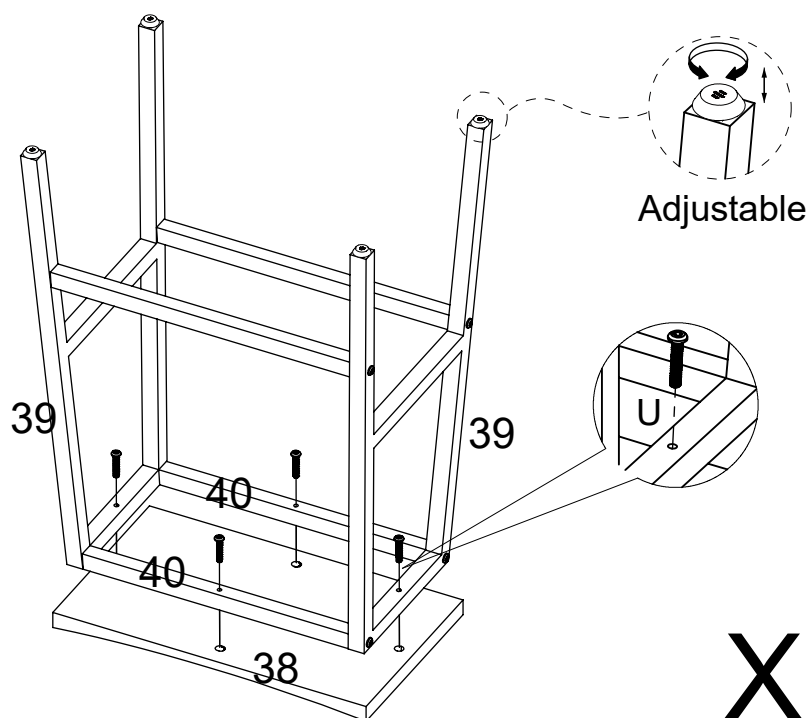
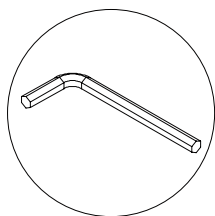

## Step 52

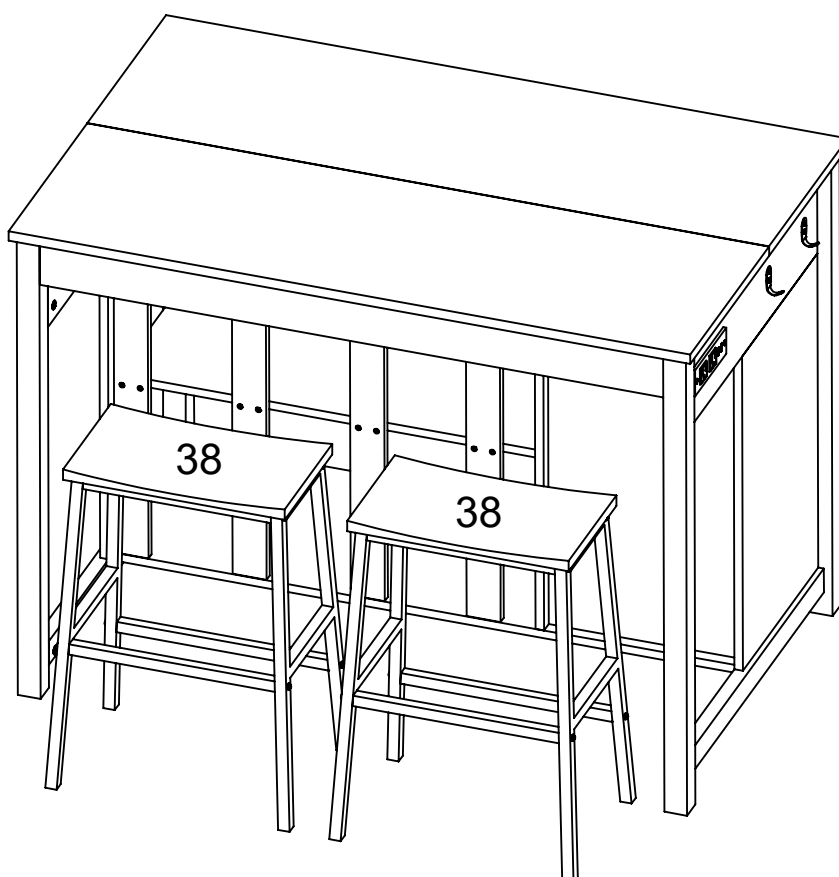

# Assembly Instructions

## A Guide to Wall Mounting & Fixings

### Important notes:



Important: To make sure there is NO hidden wires or pipes inside the walls when drilling.

If plastic wall plugs (rawl plugs) are supplied with your product, eg:

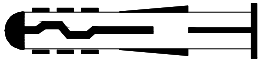

For Block Masonry Walls.

If you have any doubt about the correct wall plugs for your walls, please seek professional advice before assembling.

Make sure that the screws and wall plugs being used are suitable for supporting your unit. Consult a qualified tradesperson if you are not sure.



Hints:

1. General rule: always use a larger screw and wall plug if you are not sure.
2. Ensure you use the recommended drill bit to match the wall plug and hole size.
3. Ensure you drill the hole horizontally; do not force the drill or enlarge the hole.
4. Take extra care when drilling high walls, ceilings and ceramic tiles. Ensure
5. Ensure wall plugs are inserted beyond the thickness of the ceramic tiles to avoid the tiles splitting or cracking.

### Types of walls

You can use one of the following types of wall plug if your walls are made of brick, breeze block, concrete, stone or wood.

No. 1 "General Purpose" wall plug

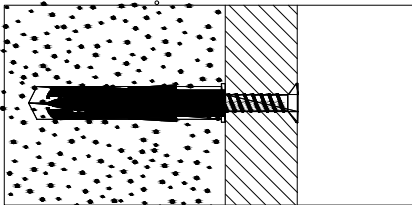

Generally aerated blocks should not be used to support heavy loads,

For light loads, general purpose wall plugs can be used.

No. 3 "Cavity Fixing" wall plug

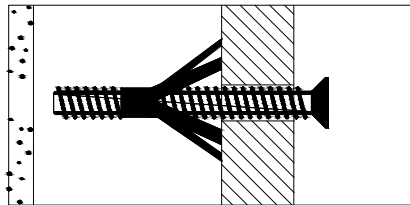

For use with plasterboard partitions or hollow wooden doors.

No. 5 "Hammer Fixing" wall plug

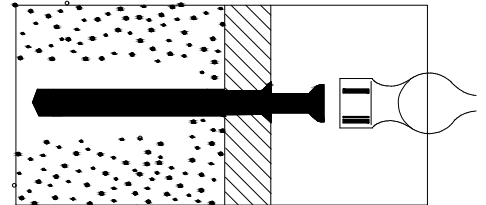

rather than the plasterboard. the retaining wall.

No. 2 "Plasterboard" wall plug

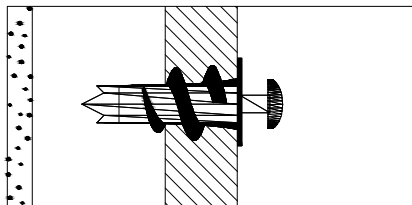

For use when attaching light loads onto plasterboard partitions.

No. 4 "Cavity Fixing - Heavy Duty" wall plug

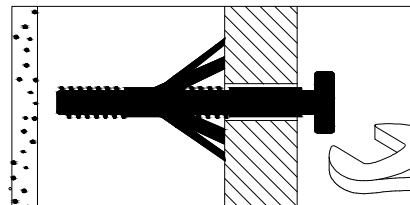

heavy loads such as shelving, wall cabinets and coat racks.

No. 6 "Shield Anchor" wall plug - heavy loads

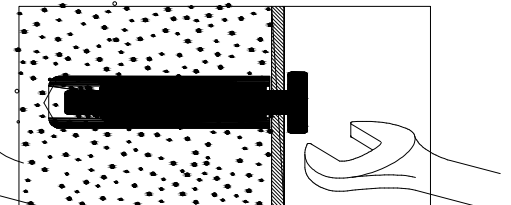

For use with heavier loads such as TV and HiFi speakers and satellite dishes etc.



### Care & Maintenance

Safety: Always check the fitting and location to ensure your safety in and around the home.

Fitting: From time to time check the fitting to ensure the wall plugs or screws do not become loose.