

ASSEMBLY INSTRUCTION

NO	PARTLIST	QTY
1	HEADBOARD CUSHION	1PC
2	LEFT HEADBOARD LEG (WITH "L" LABEL)	1PC
3	RIGHT HEADBOARD LEG (WITH "R" LABEL)	1PC
4	FOOTBOARD CUSHION	1PC
5	FOOTBOARD LEG	2PCS
6	SIDE RAIL	2PCS
7	SIDE RAIL	2PCS
8	SIDE RAIL SUPPORT LEG	2PCS
9	ROLL SLAT	2 SETS
10	CENTER SUPPORT RAIL	4PCS
11	SUPPORT LEGS WITH ADJUSTABLE FEET	8PCS
ITEM	HARDWARE	QTY
A	JCBB SCREW M8 x 20MM	8PCS
B	JCBC SCREW M6 x 25MM	8PCS
C	JCBC SCREW M6 x 45MM	14PCS
D	JCBC SCREW M6 x 100MM	2PCS
E	WOOD DOWEL M8 x 30MM	2PCS
F	SPRING WASHER M6 x 13MM	14PCS
G	FLAT WASHER M6 x 19MM	14PCS
H	SCREW M4 x 32MM	8PCS
I	L - KEY M5 x 65MM	1PC
J	L - KEY M4 x 100MM	1PC

STEP 1

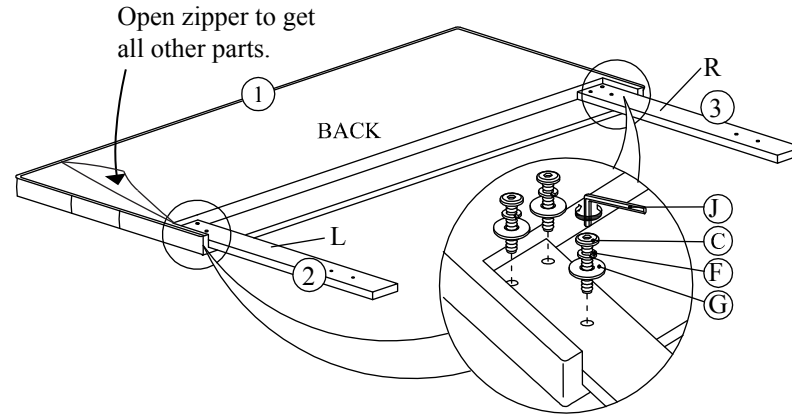

STEP 2

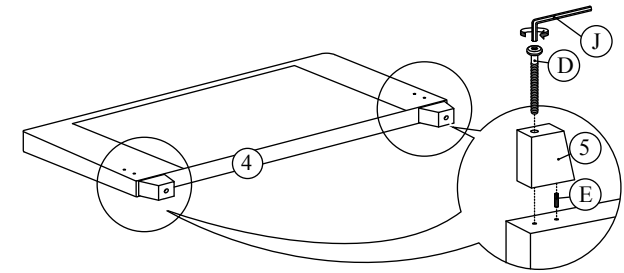

STEP 3

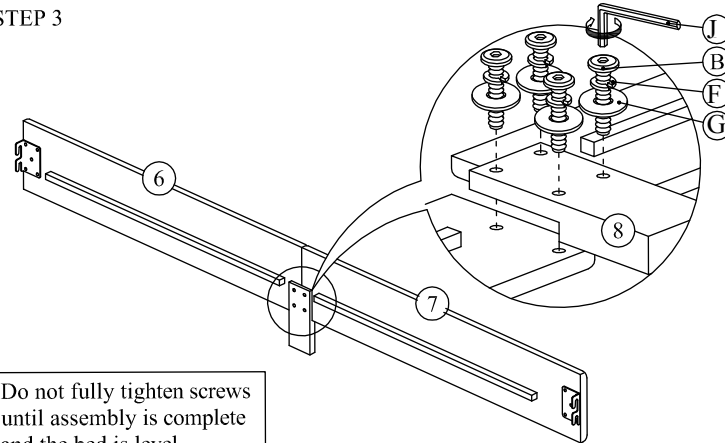

Do not fully tighten screws until assembly is complete and the bed is level.

STEP 4

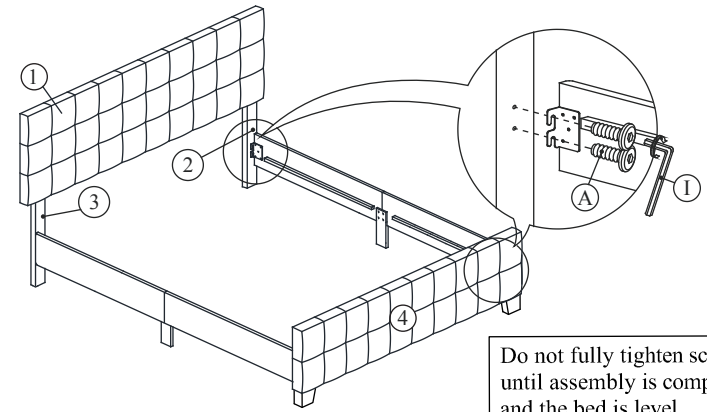

Do not fully tighten screws until assembly is complete and the bed is level.

STEP 5

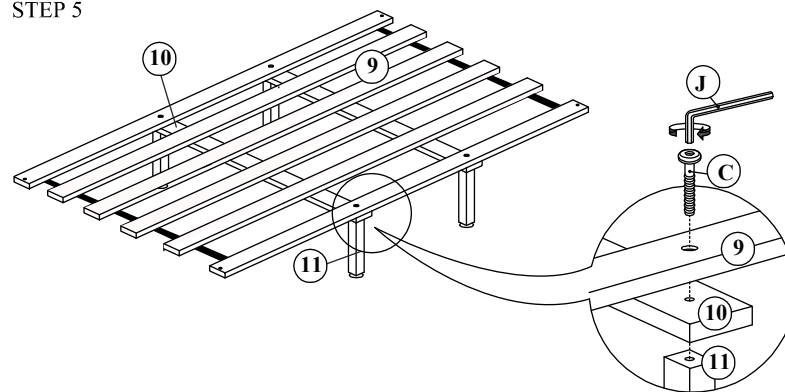

STEP 6

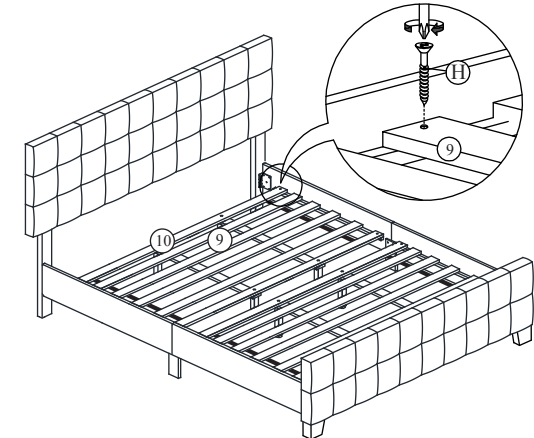

ASSEMBLY COMPLETED