

ASSEMBLY INSTRUCTION

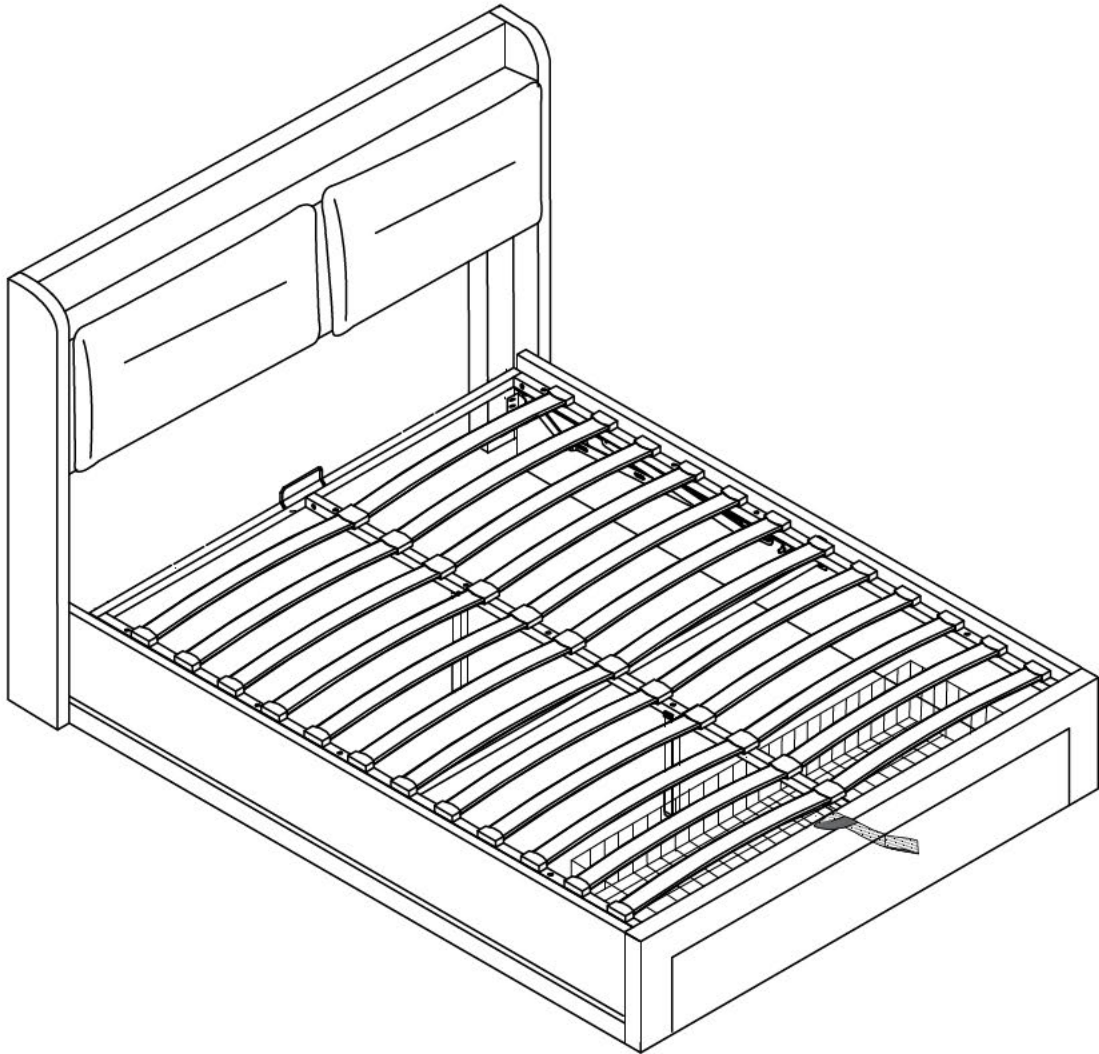

DE: Unser Produkt wird Ihnen in (2) Paketen geliefert. Die Lieferzeiten dieser (2) Pakete können abweichen, bitte haben Sie etwas Geduld und vielen Dank für Ihr Verständnis.

UK: Our product will be delivered to you in (2) packages. The delivery times of these (2) packages may differ, please be patient and thank you for your understanding.

FR: Notre produit vous sera livré en (2) colis. Les délais de livraison de ces (2) colis peuvent différer, soyez patient et merci pour votre compréhension.



ANLEITUNG

ASSEMBLY INSTRUCTION

LE MANUEL D'EMPLOI

TIPPS

1. Dieses Produkt wird für die Lieferung in 2 Pakete aufgeteilt. Sie kommen möglicherweise nicht gleichzeitig an. Bitte warte geduldig .
2. Wir danken Ihnen für den Einkauf! Wir bemühen uns, Ihnen qualitativ hochwertige Produkte zu bieten. In seltenen Fällen, dass Ihr Produkt beschädigt ist, Teile fehlt oder Sie auf Probleme bei der Montage stoßen, wenden Sie sich damit bitte an unseren Kundendienst, wir werden Ihnen die beste Lösung so schnell wie möglich bieten. Um Ihr Problem schnell zu lösen, bitte stellen Sie uns einige Bilder zur Verfügung, die das Produktproblem deutlich widerspiegeln können. Vielen Dank !
3. Setzen Sie die Schrauben in die Löcher ein und ziehen Sie die Schrauben an, aber nicht zu fest, 70 % ~ 80 % ist genug, und ziehen Sie schließlich alle Schrauben an. Wenn einige Schrauben nicht mit den Löchern ausgerichtet sind oder die Montage einiger Teile schwierig ist, stellen Sie bitte den Straffheitsgrad der Schrauben um.
4. Es wird empfohlen, dass 2 Personen das Produkt installieren.

TIPS

1. Please read the instructions fully before assembly. These instructions include important information which could ensure correct assembly. We have been working on providing high quality products for you. However, in the rare instance that your product is defective, missing parts or there are some issues, please don't hesitate to contact our customer service to submit parts requirements, assembly suggestion, or warranty claims, and we will give the best solution as soon as possible. If necessary, we need you to provide some more clear pictures of the issue.
2. Thank you for shopping! We strive to provide you with high quality products. In rare cases that your product is damaged, missing parts or you encounter assembly problems, please contact our customer service with it, we will offer you the best solution as soon as possible. In order to solve your problem quickly, please provide us with some pictures that can clearly reflect the product problem. Thanks very much !
3. Insert the screws in holes and tighten the screws, but not too tight, 70%~80% is ok, finally tighten all the screws. If some issues happened that some screws can not target to the hole or some parts are difficult to install, please adjust the tightness of the screws.
4. 2 people are recommended to finish.

CONSEILS

1. Veuillez lire attentivement les instructions avant le montage. Ces instructions contiennent des informations importantes qui pourraient garantir un montage correct. Nous avons travaillé pour vous fournir des produits de haute qualité. Cependant, dans les rares cas où votre produit est défectueux, s'il manque des pièces ou s'il y a des problèmes, n'hésitez pas à contacter notre service client pour soumettre des exigences de pièces, des suggestions d'assemblage ou des réclamations de garantie, et nous vous donnerons la meilleure solution comme dès que possible. Si nécessaire, nous avons besoin que vous fournissiez des images plus claires du problème.
2. Merci pour vos achats ! Nous nous efforçons de vous fournir des produits de haute qualité. Dans les rares cas où votre produit est endommagé, des pièces manquantes ou que vous rencontrez des problèmes de montage, veuillez contacter notre service client avec celui-ci, nous vous proposerons la meilleure solution le plus vite possible. Afin de résoudre votre problème rapidement, veuillez nous fournir des images qui peuvent clairement refléter le problème du produit. Merci beaucoup !
3. Insérez les vis dans les trous et serrez les vis, mais pas trop serré, 70% ~ 80% est ok, enfin serrez toutes les vis. Si certains problèmes surviennent, certaines vis ne peuvent pas viser le trou ou certaines pièces sont difficiles à installer, veuillez ajuster le serrage des vis.
4. Deux personnes sont recommandées pour le terminer.

English

IMPORTANT FOR GAS LIFT BEDS&MAINTAINCE

- Please place the mattress on top of the bed frame.
- Please do not pull on the strap handles.
- Please press heavily to release the compressed gas.
- Periodically check all screw & fixings to ensure they are secure.
- When moving your product, carefully lift into place.
- Wipe clean with a slightly damp cloth- please do not use abrasive chemicals or bleach.
- Do NOT allow children to operate the lift mechanism.
- Do NOT allow children near the lift base when operating the mechanism.
- Do NOT stand inside the bed or the internal storage base.
- Do NOT overload the internal storage base.
- DO NOT jump on the product or any of its parts.

Deutsch

WICHTIG FÜR GASLIFT-BETTEN&WARTUNG

- Bitte legen Sie die Matratze oben auf den Bettrahmen.
- Bitte ziehen Sie nicht an den Gurtgriffen.
- Bitte drücken Sie kräftig, um das komprimierte Gas freizusetzen.
- Überprüfen Sie regelmäßig alle Schrauben und Befestigungen, um sicherzustellen, dass sie sicher sind.
- Wenn Sie Ihr Produkt bewegen, heben Sie es vorsichtig an seinen Platz.
- Mit einem leicht feuchten Tuch abwischen - bitte keine scheuernden Chemikalien oder Bleichmittel verwenden.
- Erlauben Sie Kindern NICHT, den Hebemechanismus zu bedienen.
- Lassen Sie Kinder NICHT in die Nähe des Liftsockels, wenn Sie den Mechanismus bedienen.
- Stellen Sie sich NICHT in das Bett oder in die Innenablage.
- Überlasten Sie den internen Liftsockel NICHT.
- Springen Sie NICHT auf das Produkt oder eines seiner Teile.

Français

IMPORTANT POUR LES LITS À RELEVAGE DE GAZ&MAINTENANCE

- Veuillez placer le matelas sur le dessus du cadre de lit.
- Ne tirez pas sur les poignées de la sangle.
- Appuyez fortement pour libérer le gaz comprimé.
- Vérifiez régulièrement que toutes les vis et fixations sont bien en place.
- Lorsque vous déplacez votre produit, soulevez-le avec précaution pour le mettre en place.
- Nettoyez avec un chiffon légèrement humide - n'utilisez pas de produits chimiques abrasifs ou d'eau de Javel.
- Ne laissez pas les enfants utiliser le mécanisme de levage.
- Ne laissez pas les enfants s'approcher de la base de levage lorsqu'ils actionnent le mécanisme.
- Ne vous tenez PAS à l'intérieur du lit ou de la base de stockage interne.
- Ne surchargez pas la base de stockage interne.
- Ne pas sauter sur le produit ou l'une de ses parties.

Italiano

IMPORTANTE PER I LETTI CON SOLLEVAMENTO A GAS E LA MANUTENZIONE

- Posizionare il materasso sopra la struttura del letto.
- Non tirare le maniglie della cinghia.
- Premere con forza per rilasciare il gas compresso.
- Controllare periodicamente tutte le viti e i fissaggi per assicurarsi che siano saldi.
- Quando si sposta il prodotto, sollevarlo con cautela.
- Pulire con un panno leggermente umido, senza usare prodotti chimici abrasivi o candeggina.
- **NON** permettere ai bambini di azionare il meccanismo di sollevamento.
- **NON** permettere ai bambini di avvicinarsi alla base di sollevamento quando si aziona il meccanismo.
- **NON** sostare all'interno del letto o della base di contenimento interna.
- **NON** sovraccaricare la base di contenimento interna.
- **NON** saltare sul prodotto o sulle sue parti.

Español

IMPORTANTE PARA LAS CAMAS ELEVADORAS DE GAS&MANTENIMIENTO

- Coloque el colchón sobre el somier.
- No tire de las asas de la correa.
- Presione con fuerza para liberar el gas comprimido.
- Compruebe periódicamente que todos los tornillos y fijaciones estén bien sujetos.
- Al mover el producto, levántelo con cuidado para colocarlo en su sitio.
- Limpie con un paño ligeramente humedecido; no utilice productos químicos abrasivos ni lejía.
- **NO** permita que los niños accionen el mecanismo de elevación.
- **NO** permita que los niños se acerquen a la base elevadora cuando accionen el mecanismo.
- **NO** se ponga de pie dentro de la cama o de la base de almacenamiento interna.
- **NO** sobrecargue el somier.
- **NO** salte sobre el producto ni sobre ninguna de sus piezas.

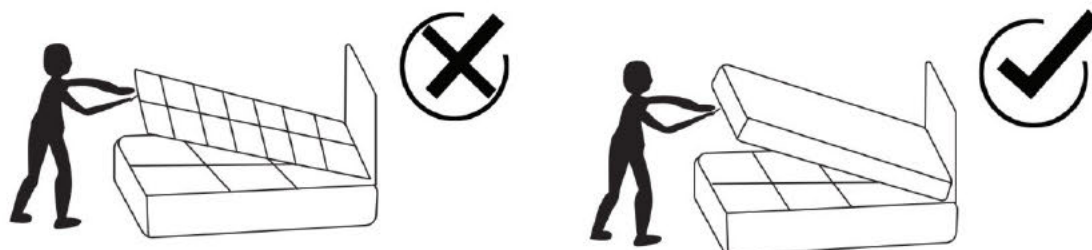



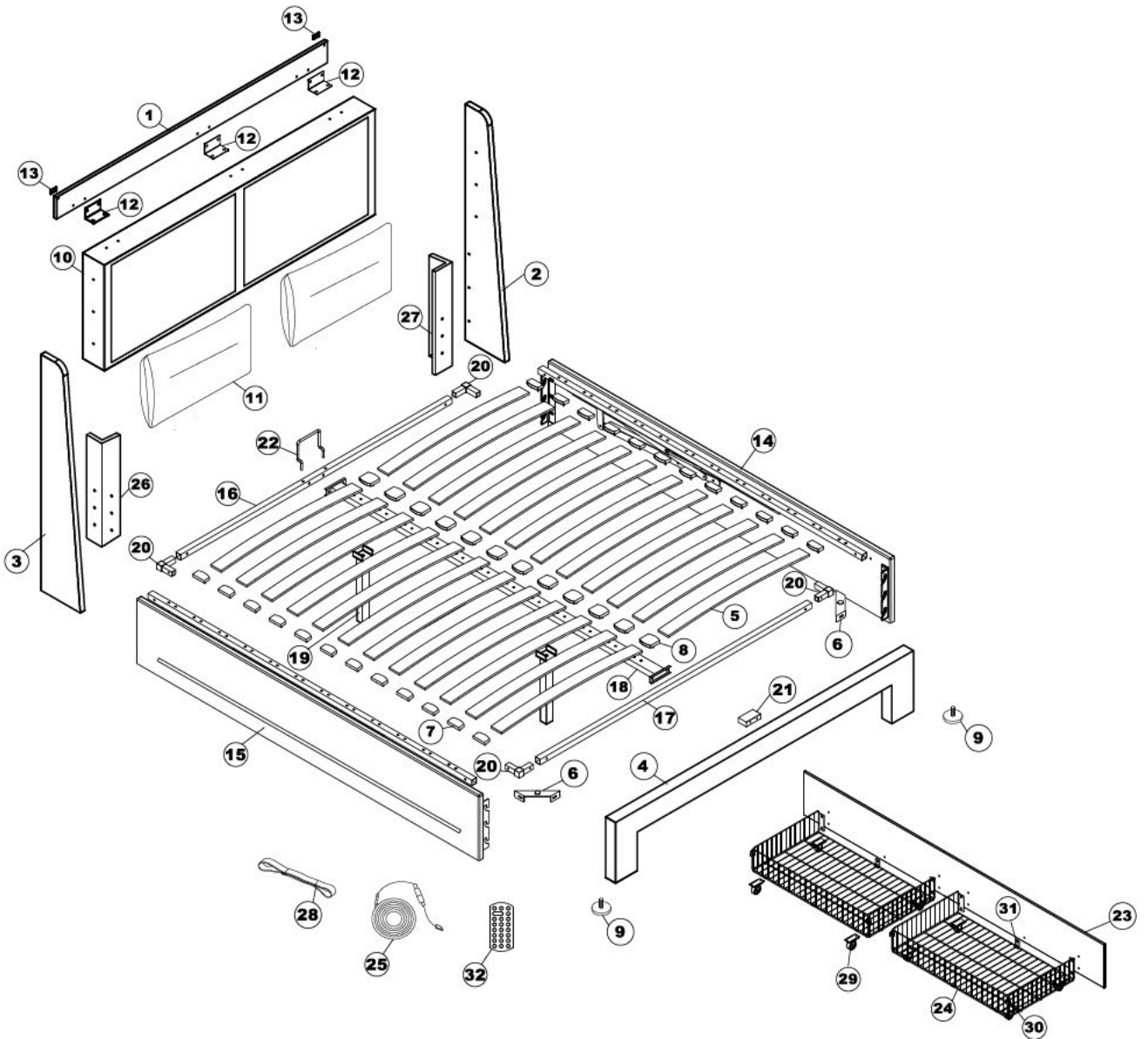











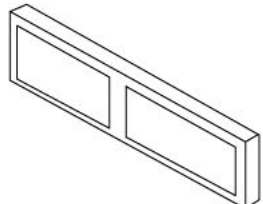
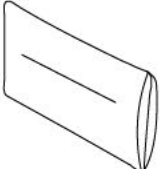



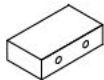

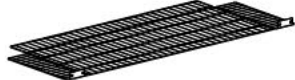

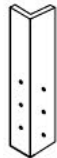
ASSEMBLY INSTRUCTION



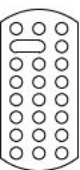
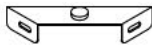

ASSEMBLY INSTRUCTION

Part List-Teileliste-Liste des pièces N606P230083





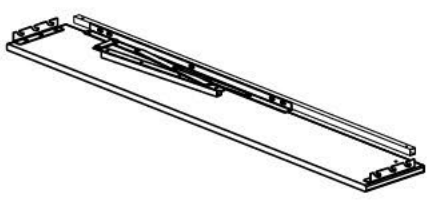
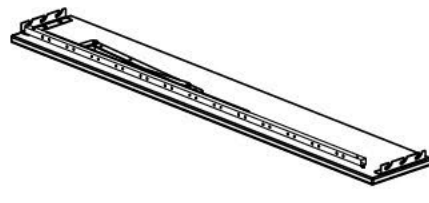
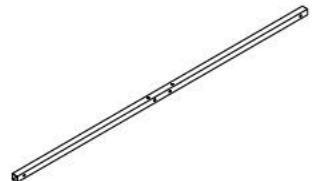
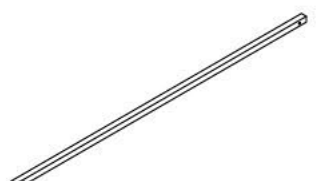

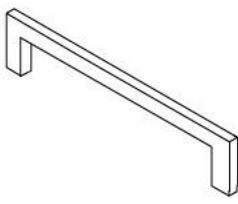
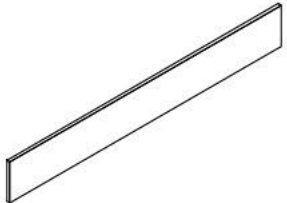





<p>1</p>  <p>1pc</p>	<p>2</p>  <p>1pc</p>	<p>3</p>  <p>1pc</p>	<p>5</p>  <p>24pcs</p>	
<p>7</p>  <p>24pcs</p>	<p>8</p>  <p>12pcs</p>	<p>9</p>  <p>2pcs</p>	<p>10</p>  <p>1pc</p>	
<p>11</p>  <p>2pcs</p>	<p>12</p>  <p>3pcs</p>	<p>13</p>  <p>2pcs</p>	<p>20</p>  <p>4pcs</p>	
<p>21</p>  <p>1pc</p>	<p>22</p>  <p>1pc</p>	<p>24</p>  <p>2pcs</p>	<p>25</p>  <p>1pc</p>	
<p>26</p>  <p>1pc</p>	<p>27</p>  <p>1pc</p>	<p>28</p>  <p>1pc</p>	<p>29</p>  <p>8pcs</p>	
<p>30</p>  <p>4pcs</p>	<p>31</p>  <p>2pcs</p>	<p>32</p>  <p>1pc</p>	<p>6</p>  <p>2pcs</p>	<p>19</p>  <p>2pcs</p>

ASSEMBLY INSTRUCTION

Part List-Teileliste-Liste des pièces

<p>14</p>  <p>1pc</p>	<p>15</p>  <p>1pc</p>
<p>16</p>  <p>1pc</p>	<p>17</p>  <p>1pc</p>
<p>18</p>  <p>1pc</p>	<p>4</p>  <p>1pc</p>
<p>23</p>  <p>1pc</p>	

Hardware List-Hardware-Liste-Liste du matériel

<p>A</p>  <p>M8x15 10pcs</p>	<p>B</p>  <p>M8x35 14pcs</p>	<p>C</p>  <p>M8x25 12pcs</p>	<p>D</p>  <p>M6x80 2pcs</p>
<p>E</p>  <p>M6x20 8pcs</p>	<p>G</p>  <p>M8 2pcs</p>	<p>H</p>  <p>Ø4*15L 12pcs</p>	<p>I</p>  <p>Spanner 1pc</p>
<p>J</p>  <p>M5 allen key 1pc</p>	<p>K</p>  <p>M4 allen key 1pc</p>	<p>L</p>  <p>M6x15 2pcs</p>	<p>M</p>  <p>Ø4*20L 2pcs</p>

ASSEMBLY INSTRUCTION

Step 1:

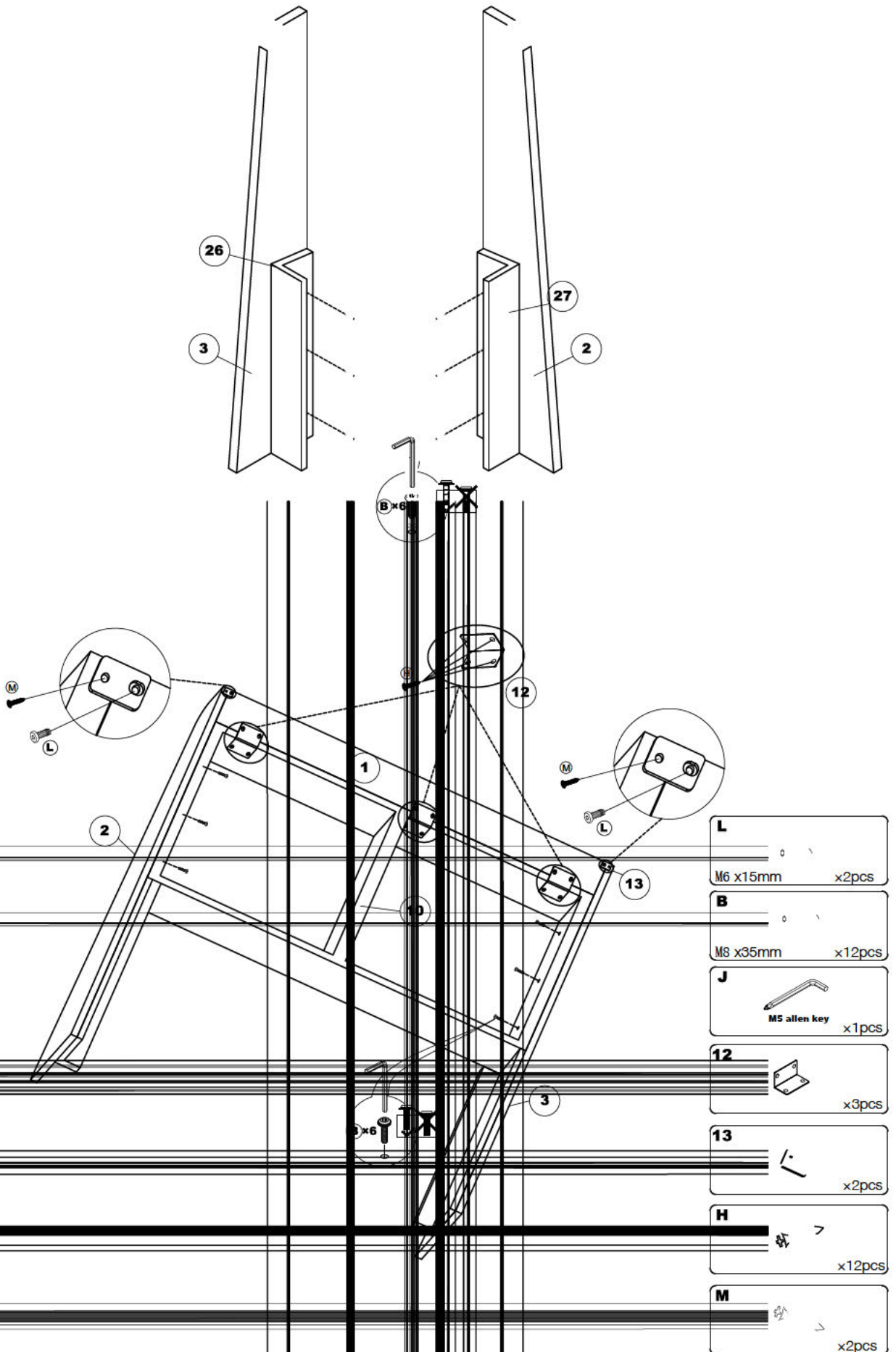

ASSEMBLY INSTRUCTION

Step2:

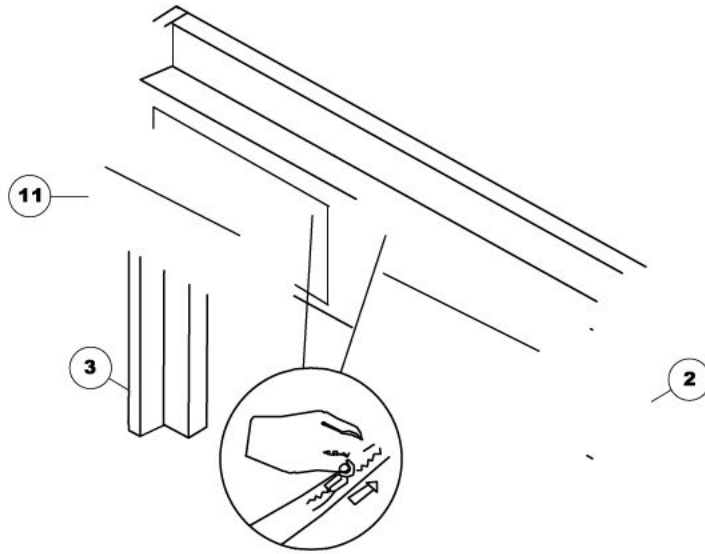

Step3:

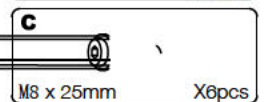
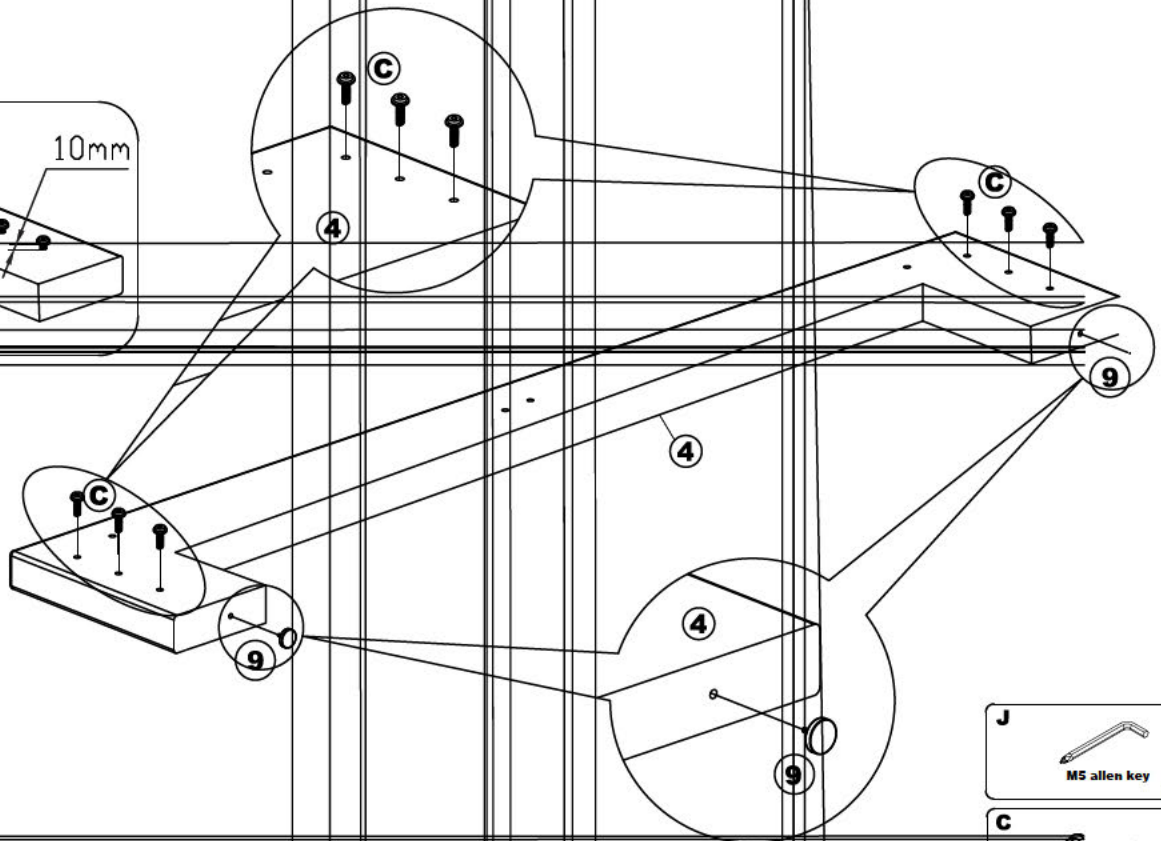
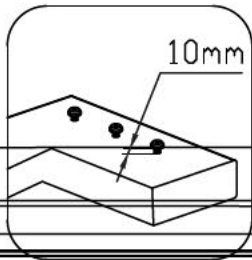

ASSEMBLY INSTRUCTION

Step4:

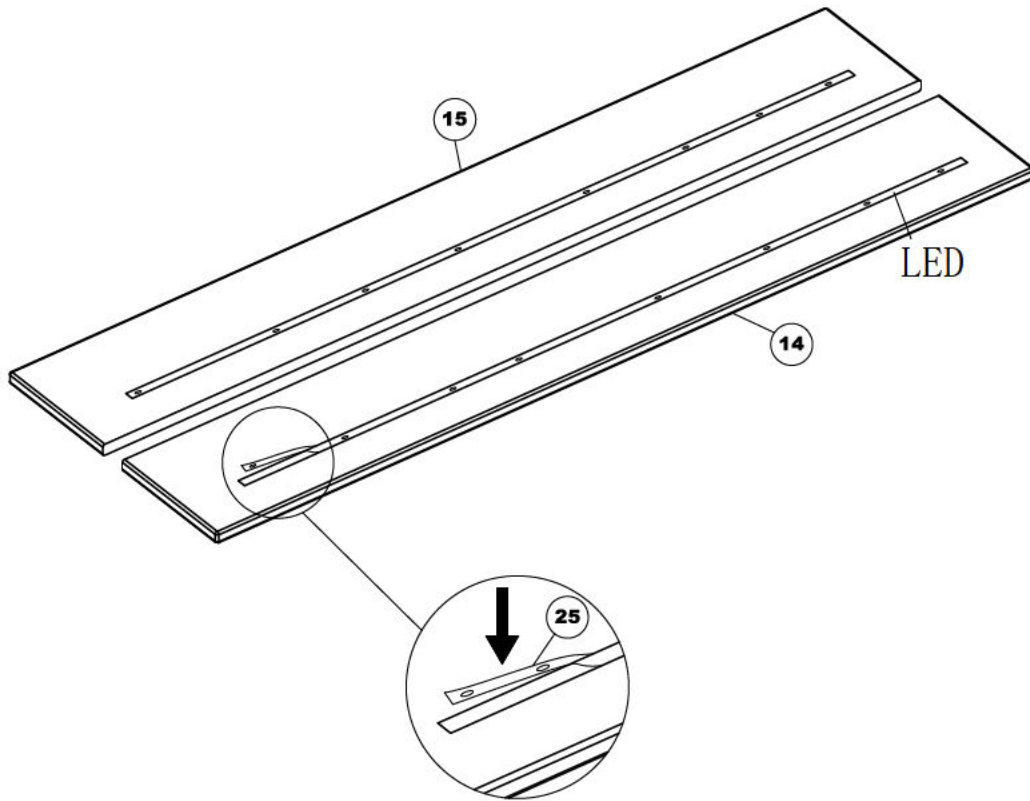



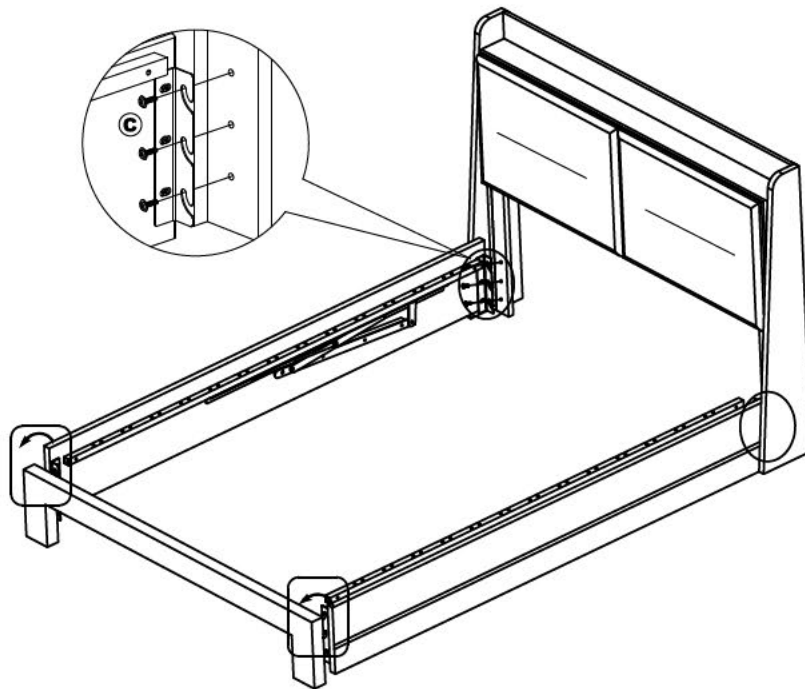

Step5:

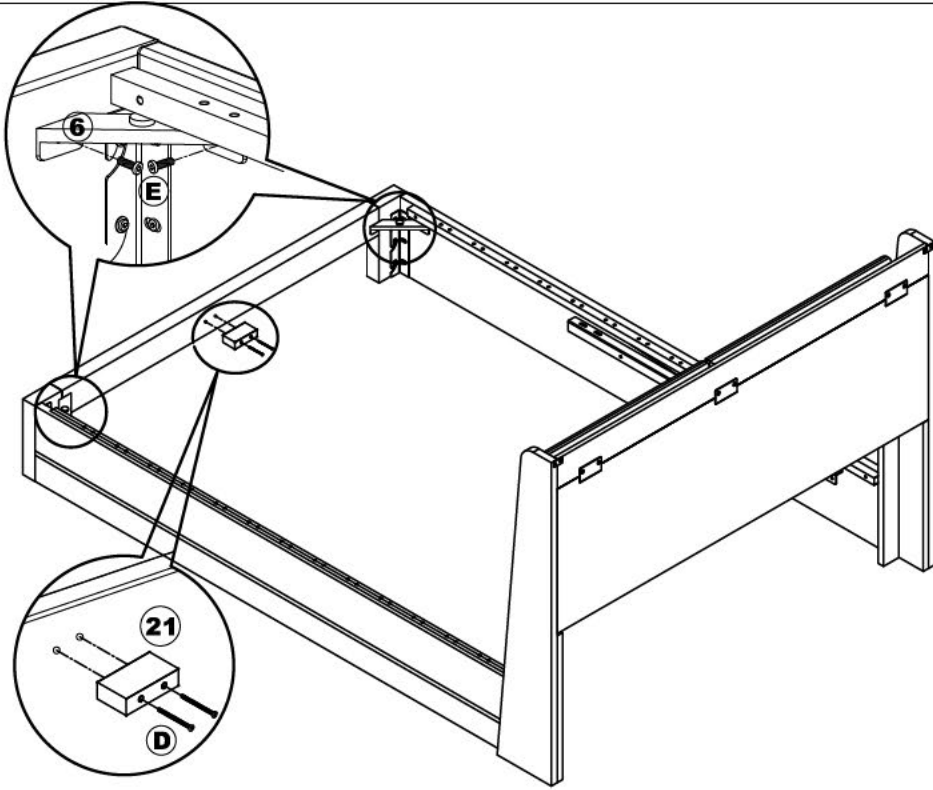

ASSEMBLY INSTRUCTION

Step6:



- K**  M4 allen key x1pc
- E**  M6 x 20mm X4pcs
- D**  M6 x 80mm X2pcs

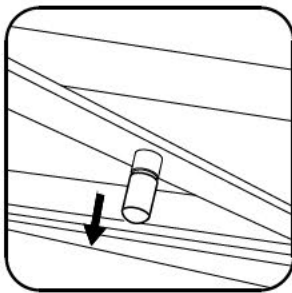

Step7:

a:

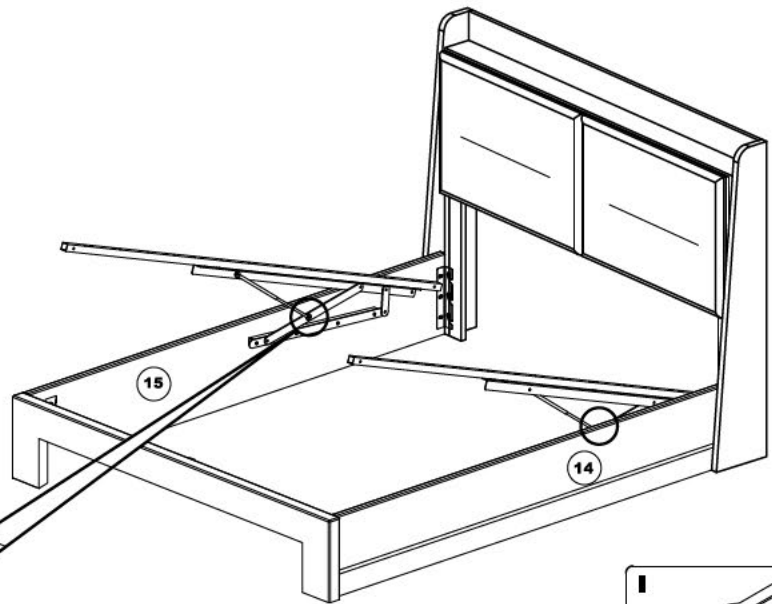
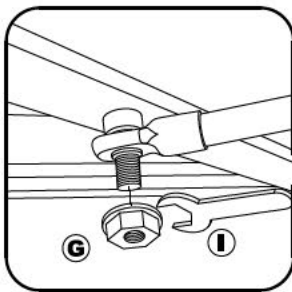

b:



- I**  Spanner X1pc
- G**  M8 X2pcs

ASSEMBLY INSTRUCTION

Step8:

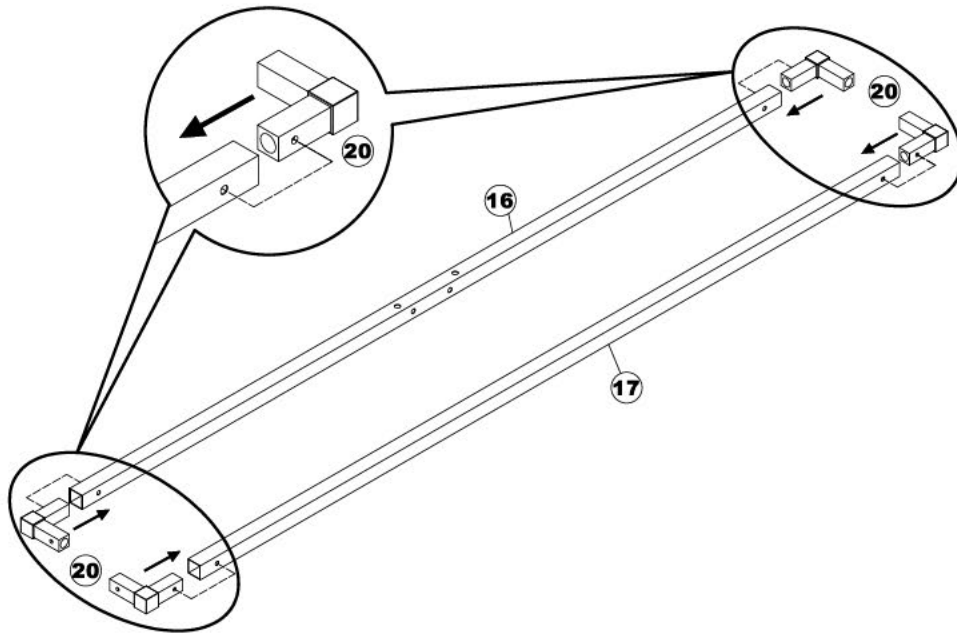

Step9:

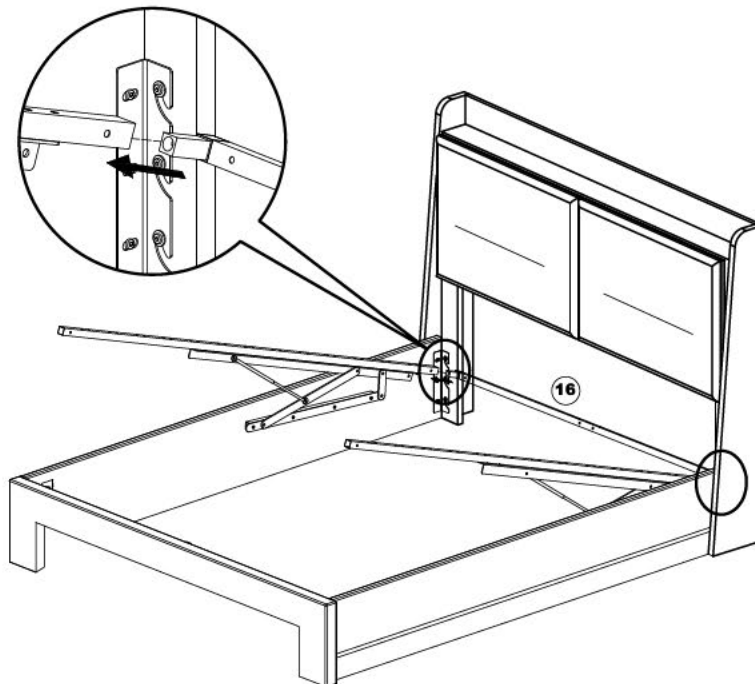

ASSEMBLY INSTRUCTION

Step10:

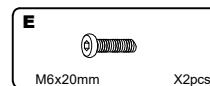
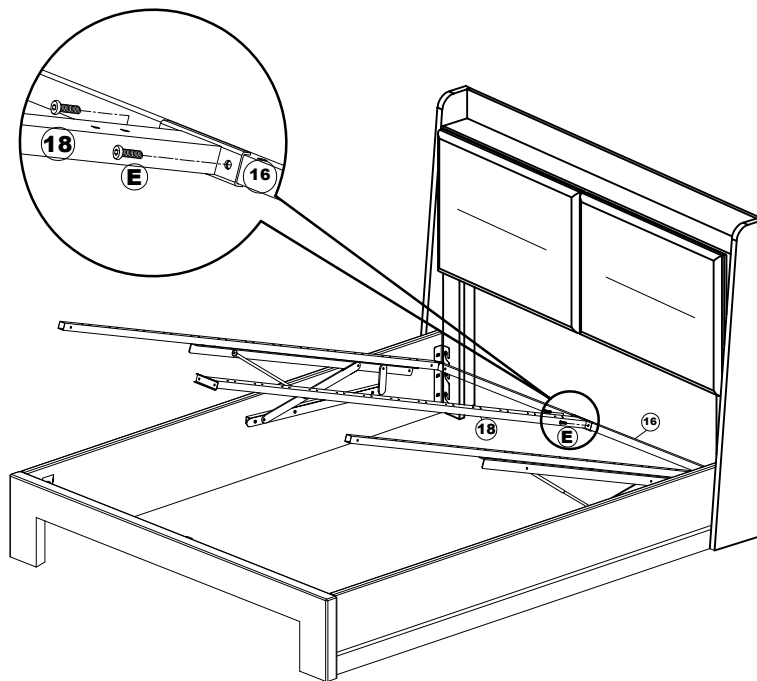

Step11:

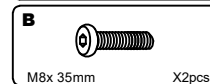
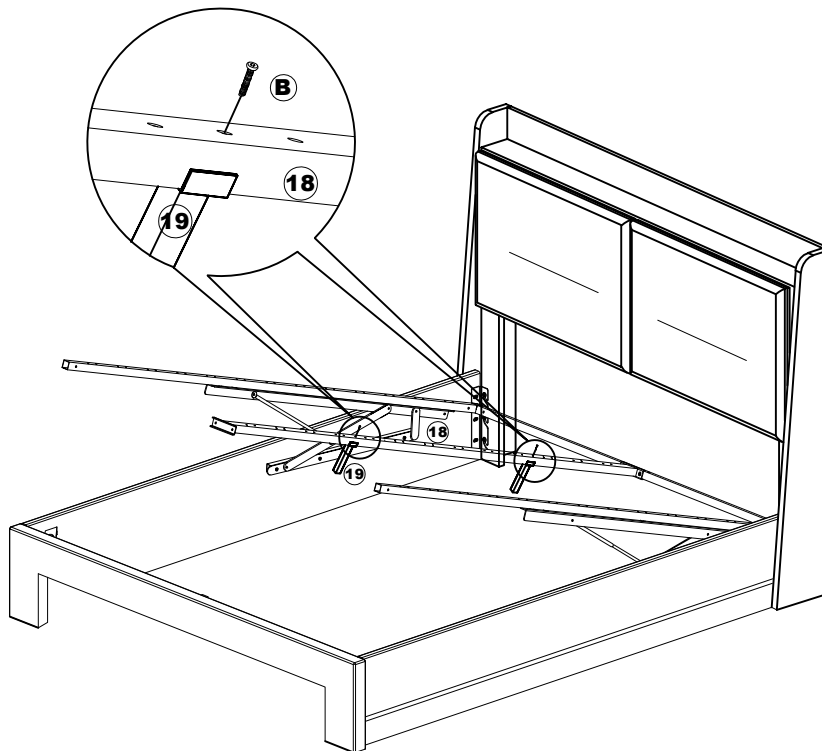

Step12:

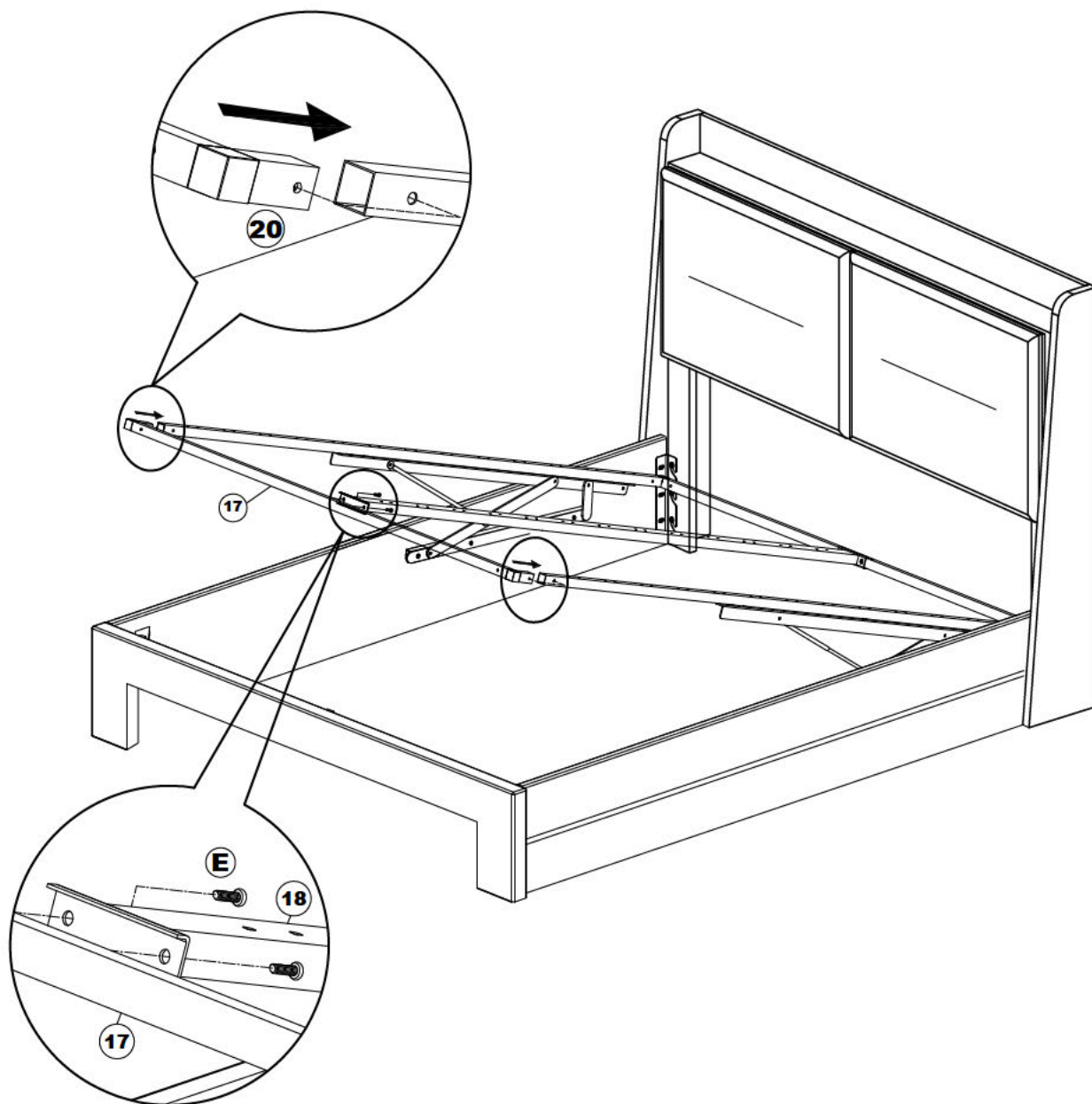

Step13:

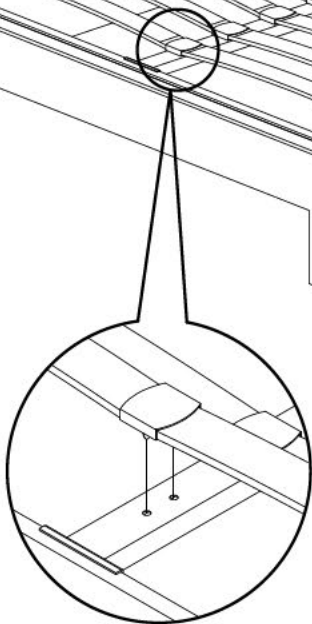
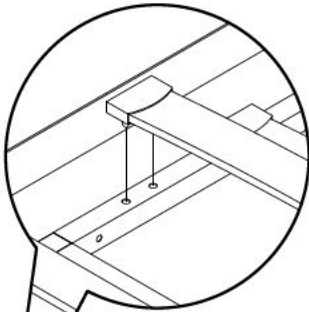
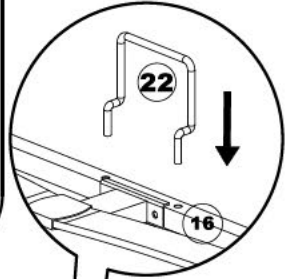
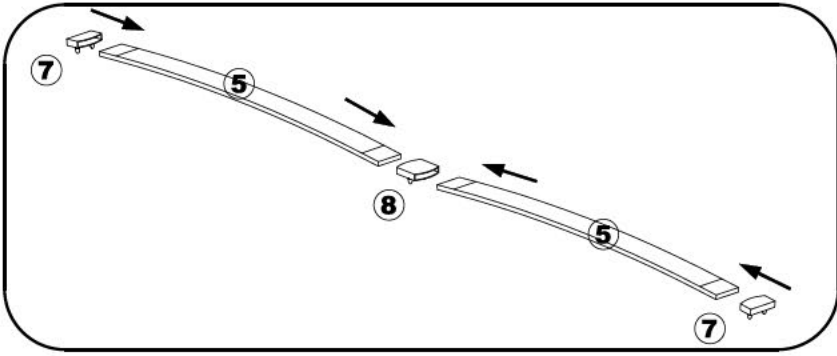
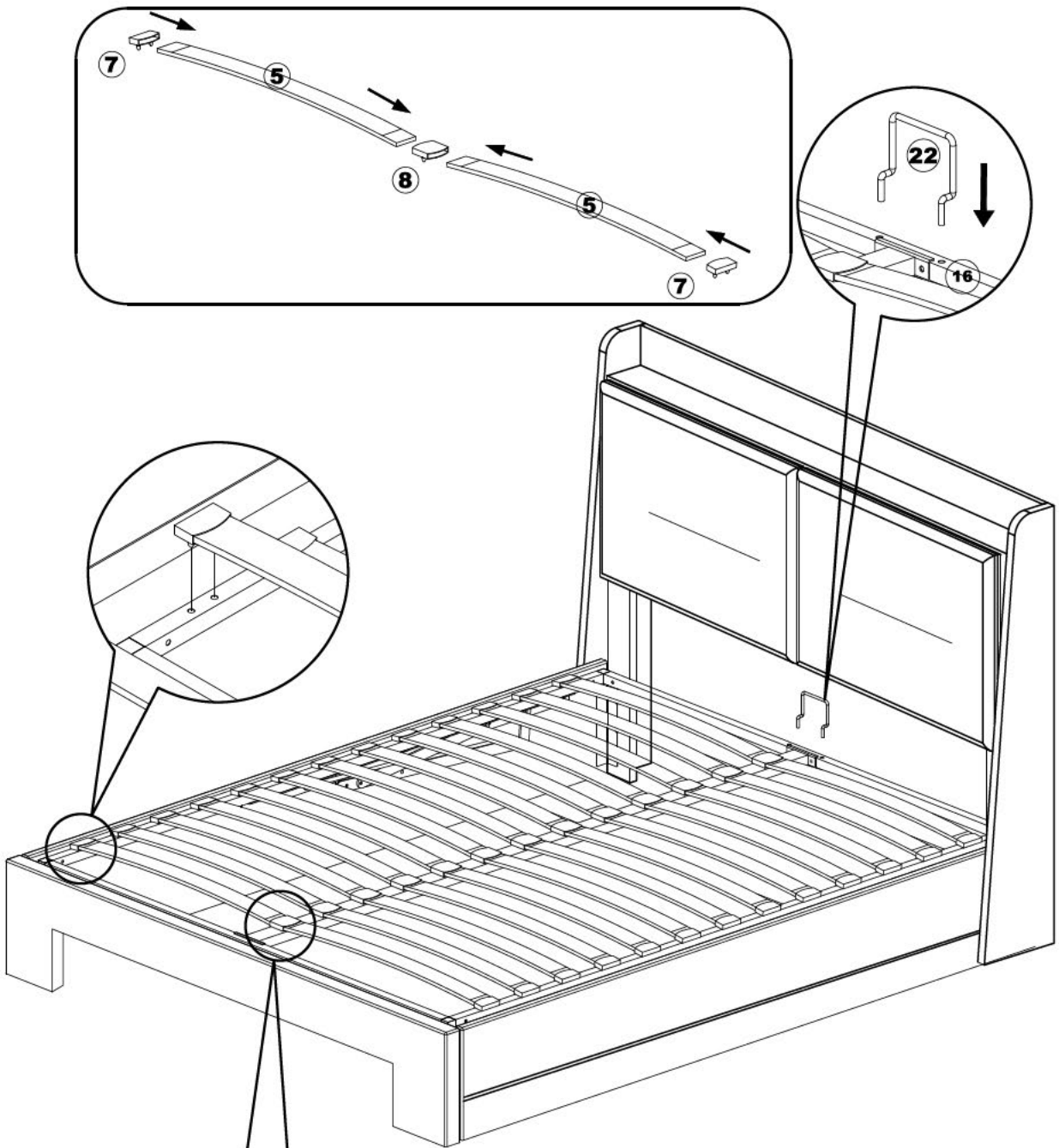

Step 14:

1

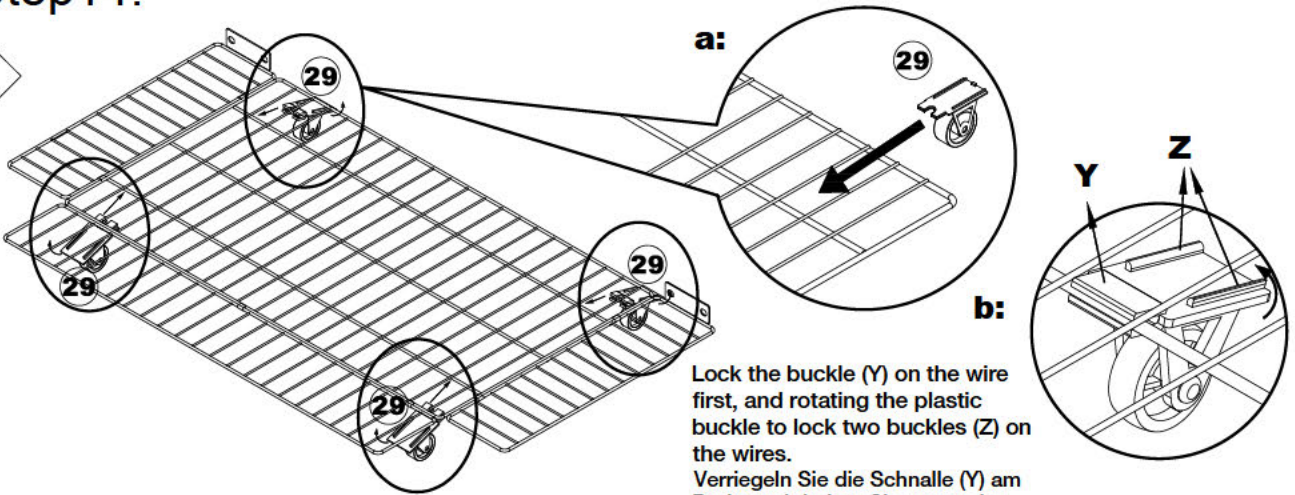

Lock the buckle (Y) on the wire first, and rotating the plastic buckle to lock two buckles (Z) on the wires.

Verriegeln Sie die Schnalle (Y) am Draht und drehen Sie zuerst den Kunststoff Schnalle zum Verriegeln von zwei Schnallen (Z) die Drähte.

Verrouillez la boucle (Y) sur le fil et tournez d'abord la boucle en plastique pour verrouiller deux boucles (Z) sur les fils.

2

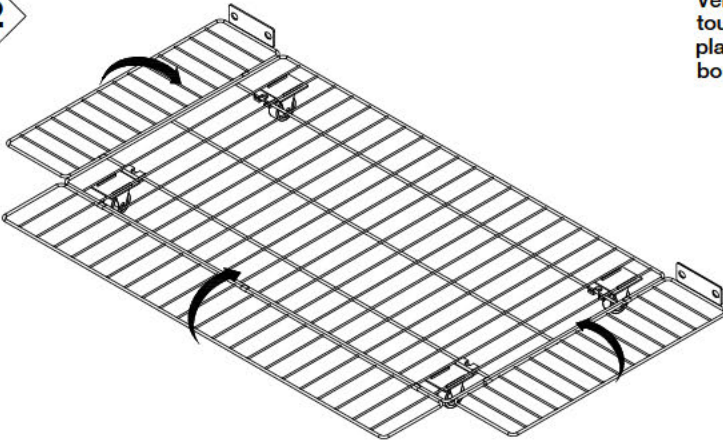

3

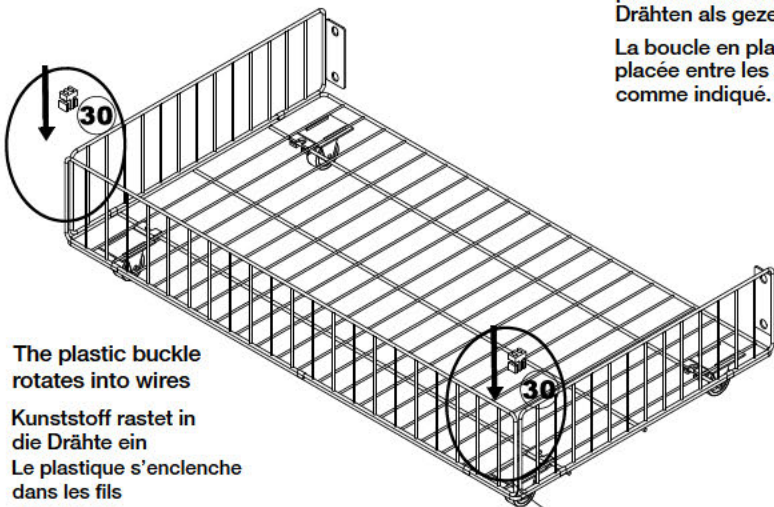

The plastic buckle rotates into wires

Kunststoff rastet in die Drähte ein

Le plastique s'enclenche dans les fils

The plastic buckle is placed between the two wires as shown.

Die Kunststoffschnalle wird platziert zwischen den beiden Drähten als gezeigt.

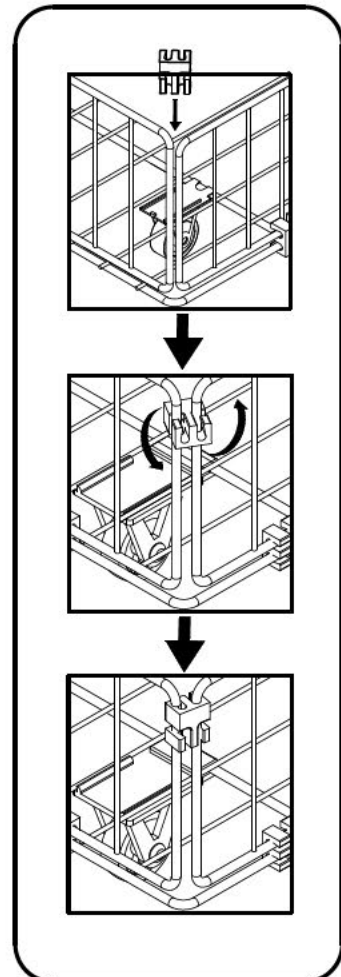

La boucle en plastique est placée entre les deux fils comme indiqué.

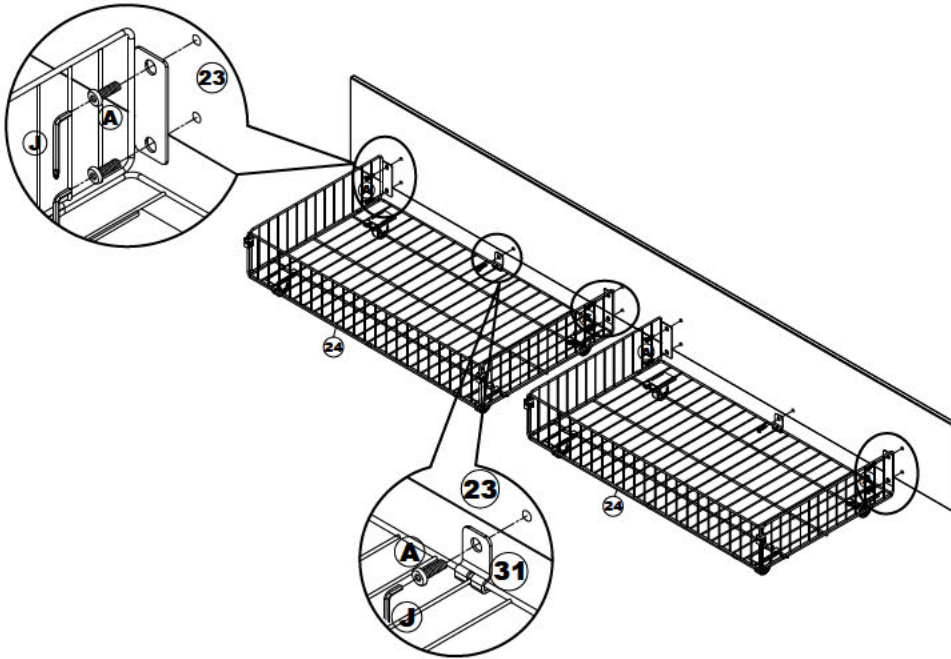

ASSEMBLY INSTRUCTION

Step15:



A		
M8 x 15mm		X10pcs
J		
M5 allen key		X1pc

Step16:

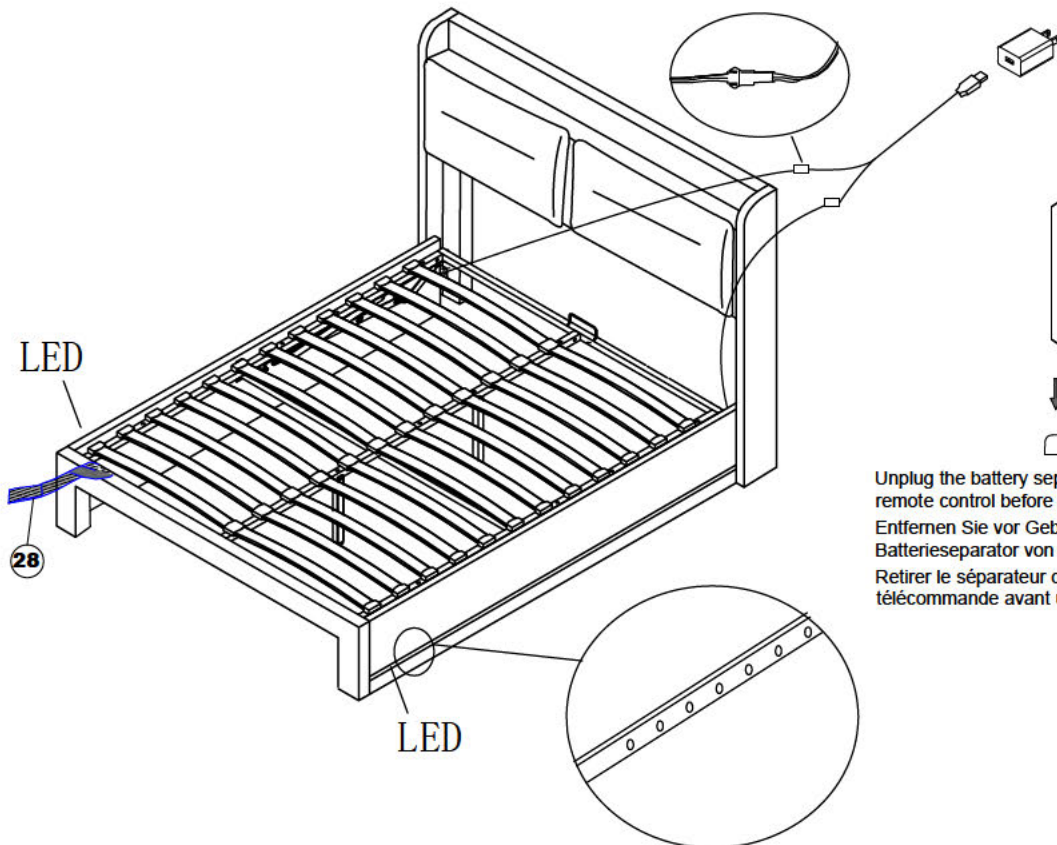

Unplug the battery separator of the remote control before use
Entfernen Sie vor Gebrauch den Batterieseparator von der Fernbedienung
Retirer le séparateur de batterie de la télécommande avant utilisation

Step 17:

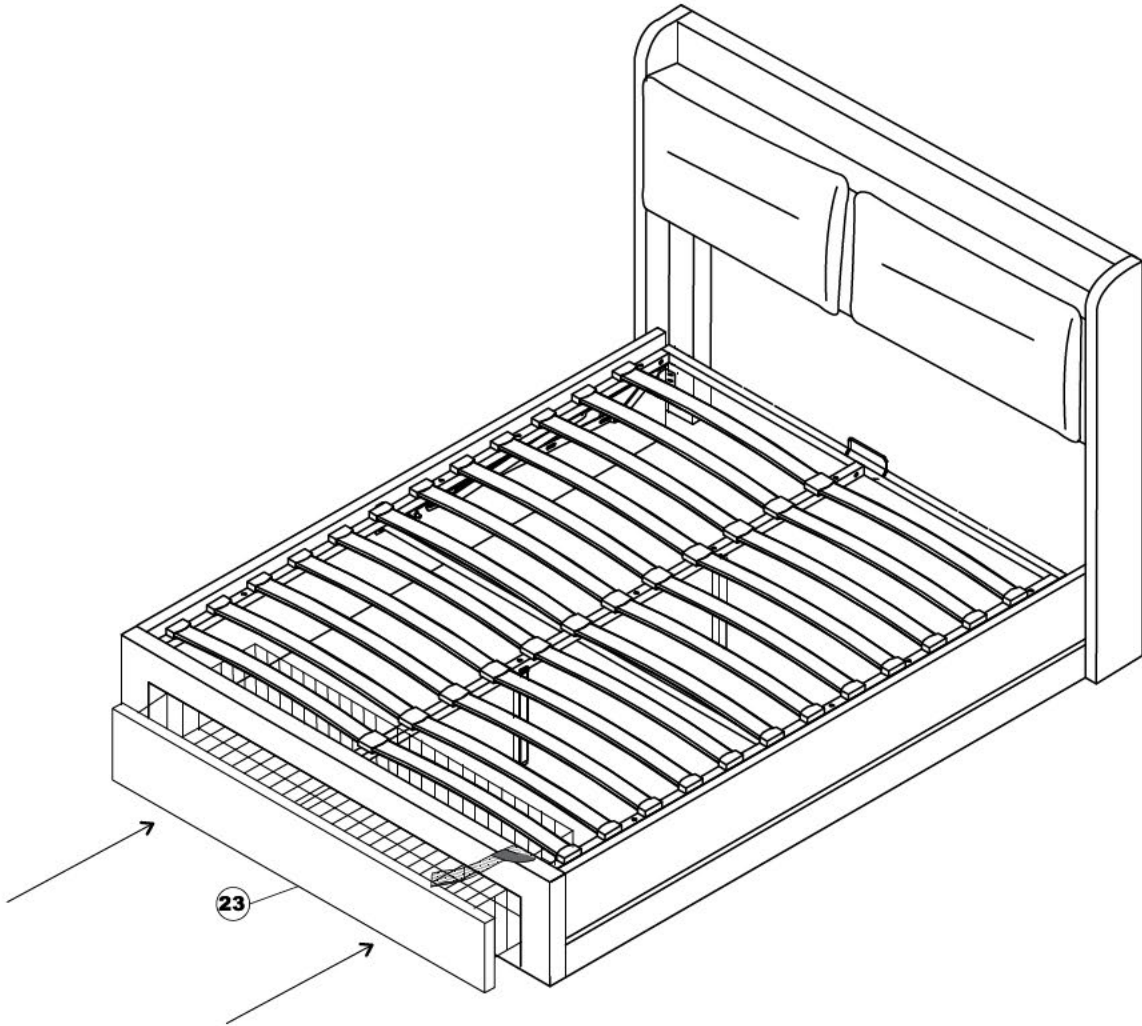

ASSEMBLY INSTRUCTION

Step 18:

Installation Complete

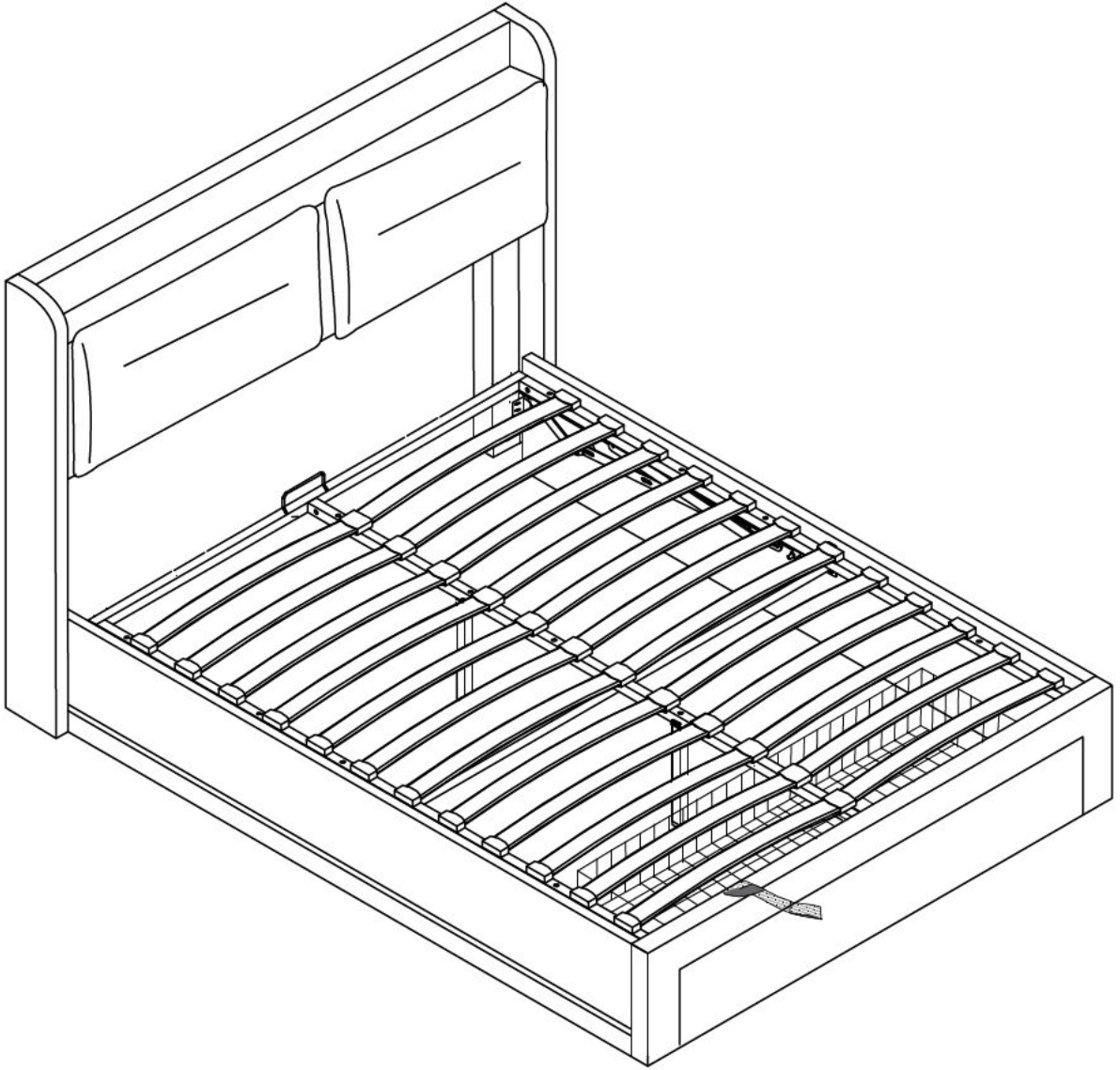

Shenzhen ZKT Technology Co., Ltd.

1/F, No. 101, Building B, No. 6, Tangwei Community Industrial Avenue,
Fuhai Street, Bao'an District, Shenzhen, China



Certificate of Compliance

Certificate Number: ZKT-2405094943C

- Certificate's Holder** : Shenzhen Pinchengxin Technology Co., Ltd
3rd Floor, 8th Building Yuanling Industrial Zone, No. 39
Yuanlingcun Road, Shiyan Street, Bao'an District,
Shenzhen
- Manufacturer** : Shenzhen Pinchengxin Technology Co., Ltd
3rd Floor, 8th Building Yuanling Industrial Zone, No. 39
Yuanlingcun Road, Shiyan Street, Bao'an District,
Shenzhen
- Trade Mark** : N/A
- Product** : 5050 RGB LED Strip Lights with Bluetooth App Controller
and 2.4G Remote
- Model(s)** : 5050 RGB LED Strip Lights
- Test Standard** : Art.3.1(a) Safety BS EN IEC 62368-1:2020+A11:2020
Art.3.1(a) Health BS EN IEC 62311:2020
BS EN 50665:2017
Art.3.1(b) EMC ETSI EN 301 489-1 V2.2.3 (2019-11)
ETSI EN 301 489-17 V3.2.4 (2020-09)
Art.3.2 Radio ETSI EN 300 328 V2.2.2 (2019-07)

This Attestation of Compliance is issued on a voluntary basis for electrical equipment below the voltage limits of Radio Equipment Directive (RED) SI 2017 No.1206. The essential requirements are fulfilled accordingly based on the technical specifications applicable at the time of issuance.

**UK
CA**



This Certificate of Conformity is based on single evaluation of the submitted sample(s) of the above mentioned product. It does not imply an assessment of the whole product and relevant Directives to be observed.