

ASSEMBLY INSTRUCTIONS

ASSEMBLY TIPS

1. Remove hardware from box and sort by size.
2. Please check to see that all hardware and parts are present prior to start of assembly.
3. Please follow attached instruction in the same sequence as numbered to assure fast & easy assembly.



Warning !

1. Don't attempt to repair or modify parts that are broken or defective. Please contact the store immediately.
2. This product is for home use only and not intended for commercial establishment.

PARTS IDENTIFICATION



HARDWARE IDENTIFICATION



NOTE : MANUFACTURER DOES NOT PROVIDE ITEM 1

STEP 1

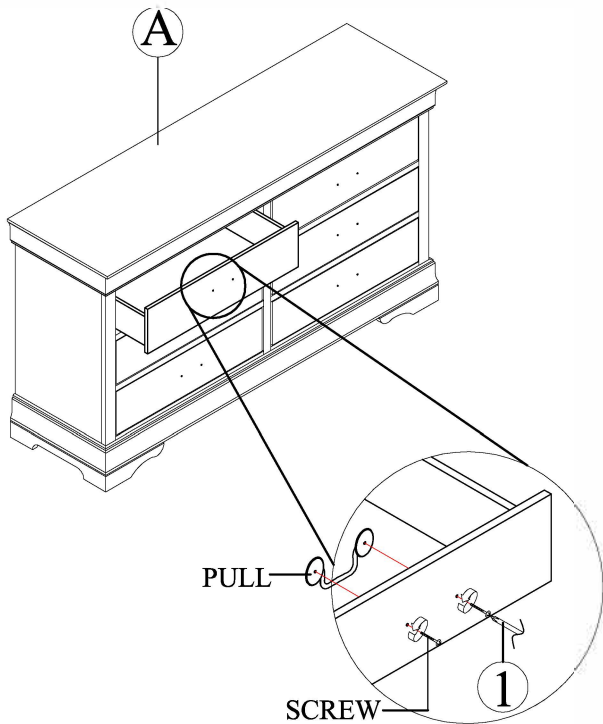

Unscrew drawer pull from the back of drawer front using screw driver (not provided)

STEP 2

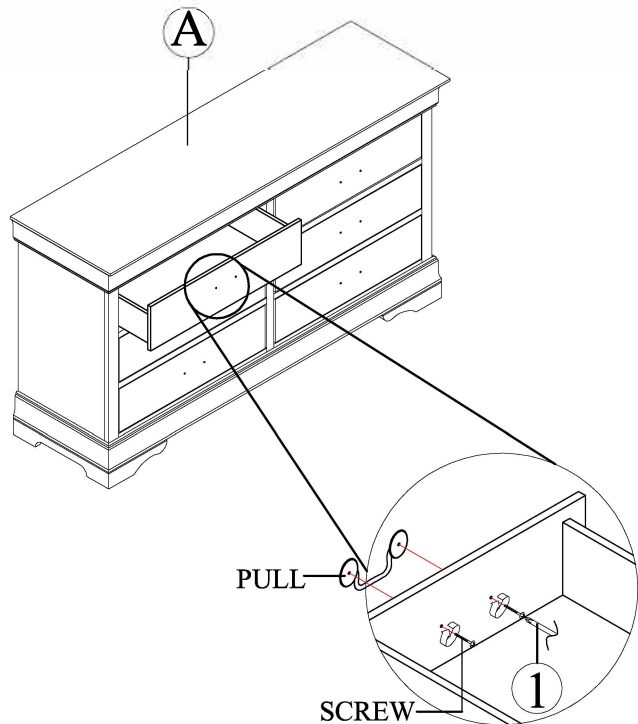

Align and fasten drawer pull to drawer front using screw and tighten with screw driver (not provided).

ANTI - TIPPING KIT



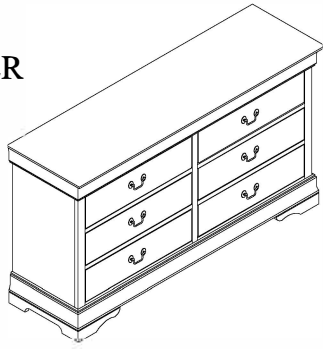

PARTS IDENTIFICATION

A. DRESSER



1SET

HARDWARE IDENTIFICATION

- | | | | |
|----|------------------------------------------------------------------------------------|-------------|-------|
| 1. |  | SHORT SCREW | 1PC. |
| 2. |  | LONG SCREW | 1PC. |
| 3. |  | CABLE TIE | 1PC. |
| 4. |  | L BRACKET | 2PCS. |

This tip restraint must be attached to a wall stud using long screw enclosed.

STEP 1

Attach a bracket securely to the back top rail of the dresser using short screw provided, through the smaller hole.

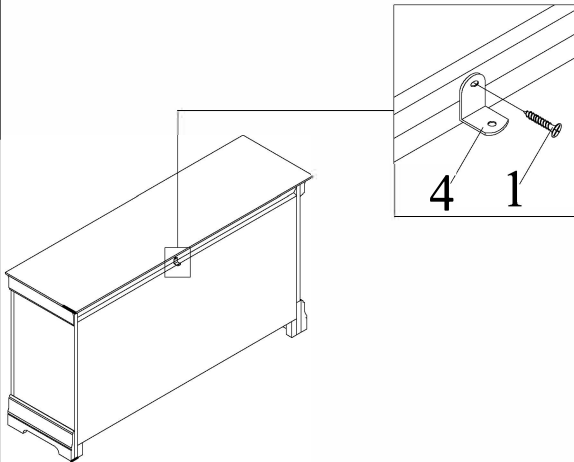

STEP 2

Locate the other bracket on the wall over a wall stud and two inches below the mounting bracket secured to the back of dresser. Attached to the wall stud using the long screw provided, through the smaller hole.

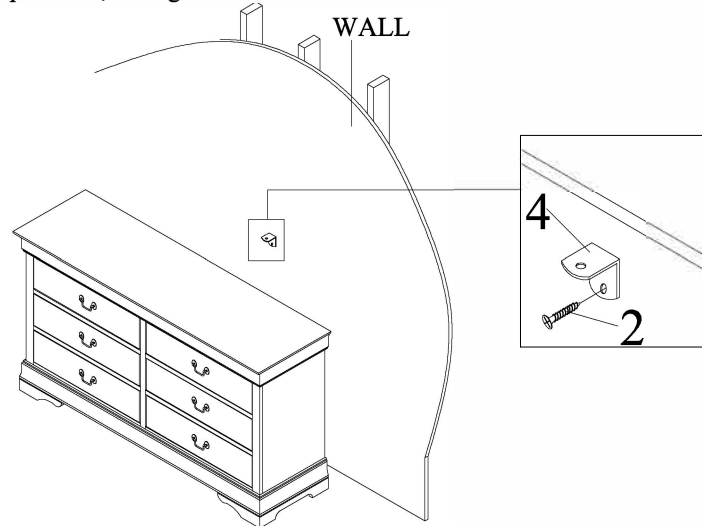

STEP 3

Place the dresser into position so both mounting brackets are vertically in line. Lace the end of the restraint strap through the larger hole in each mounting bracket. Bring both ends together and slide the flat end through the locking end and draw it through until all slack is removed. Confirm that the strap is securely laced and locked.

