

N625P352253W

Product manual
Gebrauchsanweisung
Manuel du produit
Manual del producto
Manuale del prodotto

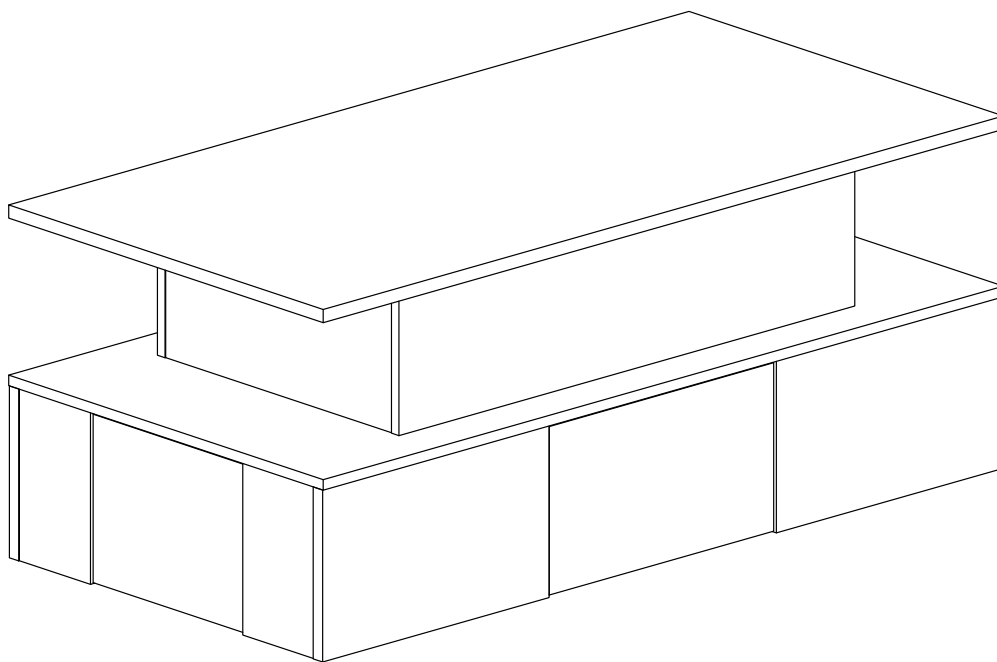

FR

Cet appareil,
ses cordons,
et batterie
se recyclent

À DÉPOSER
EN MAGASIN

À DÉPOSER
EN DÉCHÈTERIE



OU



Points de collecte sur www.quefairedemesdechets.fr
Privilégiez la réparation ou le don de votre appareil !



2PERS



35 MIN

Tool Required Not Provided

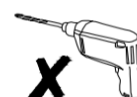
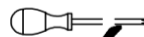
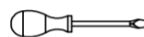



[DE]

Warnung: Lesen Sie die Anleitung vor dem Zusammenbau bitte vollständig durch. Überprüfen Sie, ob Sie alle auf den Seiten aufgeführten Komponenten und Werkzeuge haben.

Warnung: Legen Sie alle Teile auf eine ebene Fläche. Legen Sie eine weiche Decke oder Ähnliches darunter, um sie vor Kratzern oder Flecken zu schützen. Vermeiden Sie es, Komponenten über den Boden zu ziehen oder zu schieben.

Warnung: Überprüfen Sie regelmäßig alle Beschläge und Befestigungen, um sicherzustellen, dass sie sicher sind und um Unfälle zu vermeiden. Wenn Teile fehlen, kaputt, beschädigt oder abgenutzt sind, verwenden Sie das Produkt nicht weiter, bis es mit vom Hersteller autorisierten Teilen repariert wurde.

Warnung: Lassen Sie Kinder nicht auf die Möbel klettern, da dies zum Umkippen und zu schweren Verletzungen führen kann. Bauen Sie die Möbel außerhalb der Reichweite von Kindern zusammen.

Warnung: Stellen Sie die Möbel nicht in die Nähe von Feuerquellen oder heißen Gegenständen, um Brandgefahr zu vermeiden.

Warnung: Reinigen Sie die Möbel mit einem feuchten Tuch oder Alkohol. Verwenden Sie keine Reinigungsmittel mit ätzenden Chemikalien.

[EN]

Warning: Please read instructions fully before starting assembly. Check you have all the components and tools listed on pages.

Warning: Please place all parts on a flat surface. Place a soft blanket or similar underneath to protect against scratches or stains. Avoid dragging or sliding components across the floor.

Warning: Regularly check all fittings and fastenings to ensure they are secure and to prevent accidents. If any parts are missing, broken, damaged, or worn, discontinue use of the product until repairs have been made using factory authorized parts.

Warning: Do not allow children to climb on the furniture as this may result in tipping and serious personal injury. Assemble the furniture away from the reach of children.

Warning: Do not place furniture close to fire sources or high-temperature objects to avoid the risk of fire.

Warning: Clean furniture with a damp cloth or alcohol, avoid using cleaning agents containing corrosive chemicals.

[FR]

Avertissement : Veuillez lire entièrement les instructions avant de commencer l'assemblage. Vérifiez que vous disposez de tous les composants et outils répertoriés sur les pages.

Avertissement : Veuillez placer toutes les pièces sur une surface plane. Placez une couverture douce ou similaire en dessous pour les protéger des rayures ou des taches. Évitez de faire glisser les composants sur le sol.

Avertissement : Vérifiez régulièrement tous les raccords et fixations pour vous assurer qu'ils sont bien fixés et pour éviter les accidents. Si des pièces manquent, sont cassées, endommagées ou usées, cessez d'utiliser le produit jusqu'à ce que des réparations aient été effectuées à l'aide de pièces autorisées par l'usine.

Avertissement : Ne laissez pas les enfants grimper sur les meubles car cela pourrait entraîner un basculement et des blessures graves. Assemblez les meubles hors de portée des enfants.

Avertissement : Ne placez pas les meubles à proximité de sources de feu ou d'objets à haute température pour éviter tout risque d'incendie.

Avertissement : Nettoyez les meubles avec un chiffon humide ou de l'alcool, évitez d'utiliser des produits de nettoyage contenant des produits chimiques corrosifs.



[IT]

Attenzione: leggere attentamente le istruzioni prima di iniziare il montaggio. Verificare di avere tutti i componenti e gli strumenti elencati nelle pagine.

Attenzione: posizionare tutte le parti su una superficie piana. Posizionare una coperta morbida o simile sotto per proteggere da graffi o macchie. Evitare di trascinare o far scivolare i componenti sul pavimento.

Attenzione: controllare regolarmente tutti i raccordi e i dispositivi di fissaggio per assicurarsi che siano sicuri e per prevenire incidenti. Se alcune parti sono mancanti, rotte, danneggiate o usurate, interrompere l'uso del prodotto fino a quando non siano state eseguite le riparazioni utilizzando parti autorizzate dalla fabbrica.

Attenzione: non consentire ai bambini di arrampicarsi sui mobili poiché ciò potrebbe causare ribaltamenti e gravi lesioni personali. Montare i mobili lontano dalla portata dei bambini.

Attenzione: non posizionare i mobili vicino a fonti di fuoco o oggetti ad alta temperatura per evitare il rischio di incendio.

Attenzione: pulire i mobili con un panno umido o alcol, evitare di utilizzare detergenti contenenti sostanze chimiche corrosive.

[ES]

Advertencia: Lea las instrucciones completamente antes de comenzar el montaje. Compruebe que tiene todos los componentes y herramientas que se enumeran en las páginas.

Advertencia: Coloque todas las piezas sobre una superficie plana. Coloque una manta suave o algo similar debajo para protegerlas de rayones o manchas. Evite arrastrar o deslizar los componentes por el piso.

Advertencia: Verifique regularmente todos los accesorios y fijaciones para asegurarse de que estén seguros y evitar accidentes. Si falta alguna pieza, está rota, dañada o desgastada, deje de usar el producto hasta que se hayan realizado las reparaciones con piezas autorizadas de fábrica.

Advertencia: No permita que los niños se suban a los muebles, ya que esto puede provocar que se vuelquen y lesiones personales graves. Monte los muebles fuera del alcance de los niños.

Advertencia: No coloque los muebles cerca de fuentes de fuego u objetos de alta temperatura para evitar el riesgo de incendio.

Advertencia: Limpie los muebles con un paño húmedo o alcohol, evite usar agentes de limpieza que contengan químicos corrosivos.

Parts List

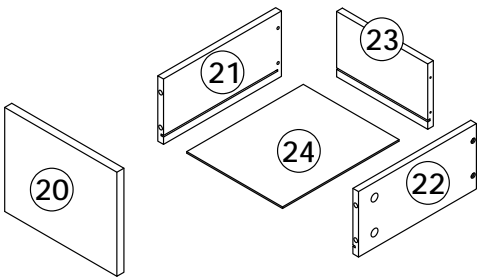
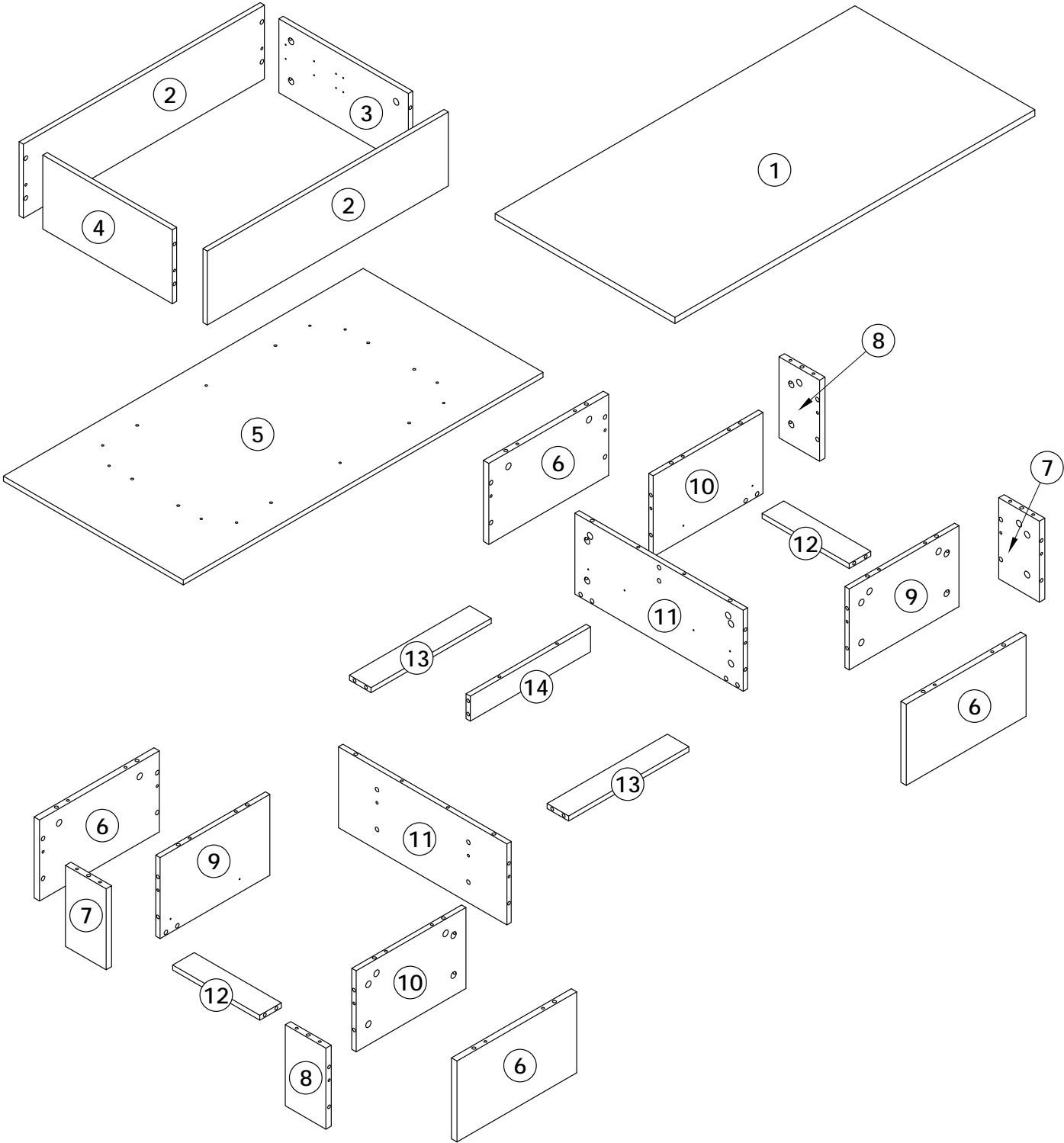

x 2

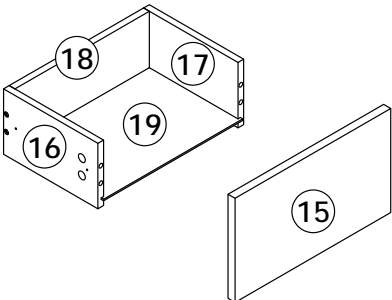

x 2

N625P352253W

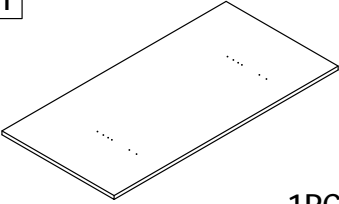
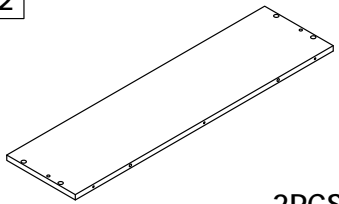
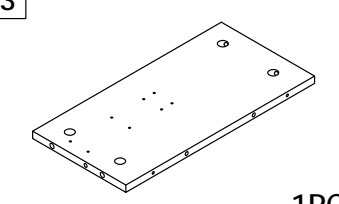
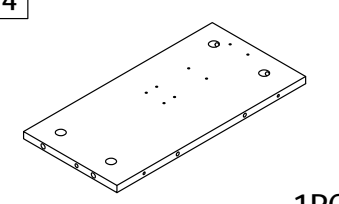
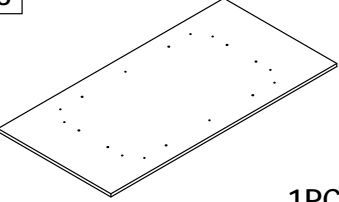
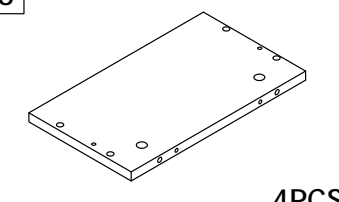
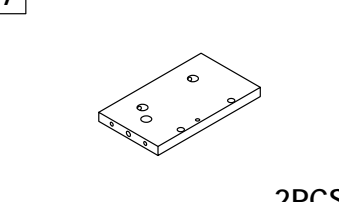
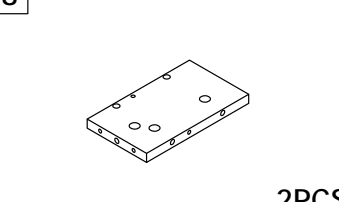
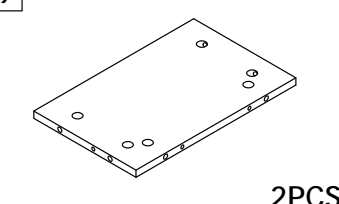
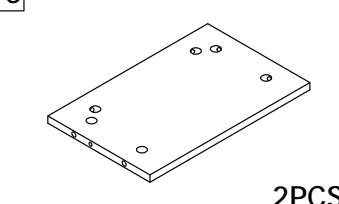
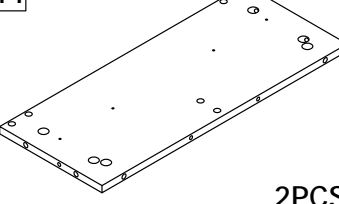
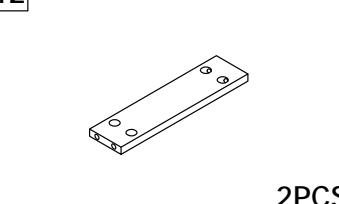
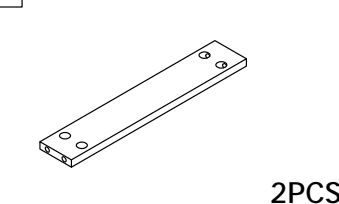
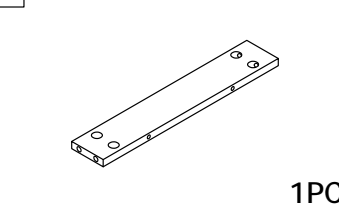
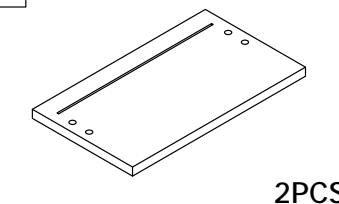
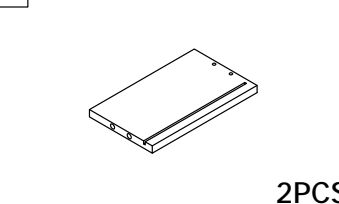
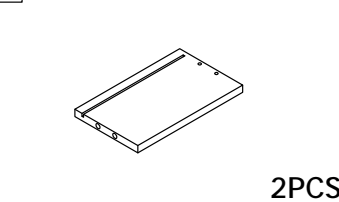
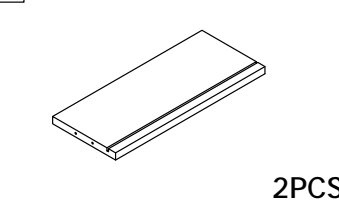
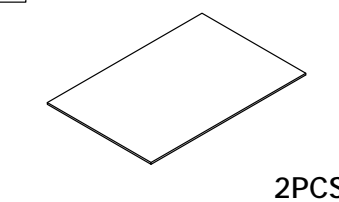
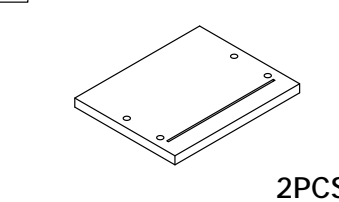
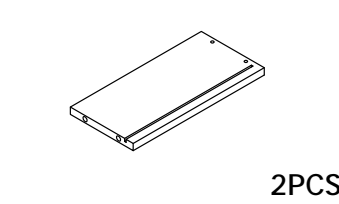
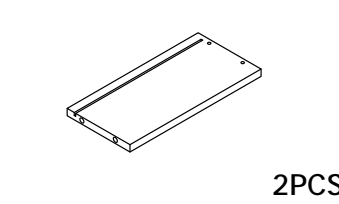
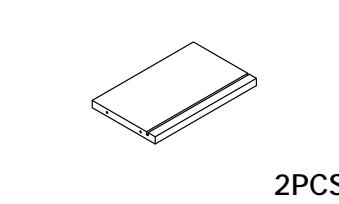
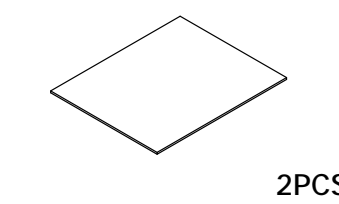
1  1PC	2  2PCS	3  1PC	4  1PC
5  1PC	6  4PCS	7  2PCS	8  2PCS
9  2PCS	10  2PCS	11  2PCS	12  2PCS
13  2PCS	14  1PC	15  2PCS	16  2PCS
17  2PCS	18  2PCS	19  2PCS	20  2PCS
21  2PCS	22  2PCS	23  2PCS	24  2PCS

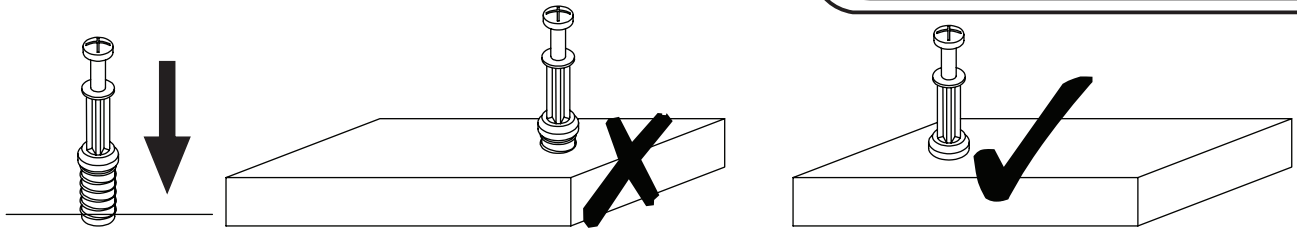

EN_QUICKFIT: Tighten quickfit until shoulder is flush with panel. Do not overtighten or undertighten.

FR_RACCORD RAPIDE: Faites serrer le raccord rapide jusqu'à ce que l'épaulement soit parfaitement encastré dans le panneau. Il ne faut ni trop serrer ni insuffisamment serrer.

ES_QUICKFIT: Apriete quickfit hasta que el hombro se descargue con el panel. NO lo sobreapriete ni lo apriete poco.

DE_QUICKFIT: Ziehen Sie den Quickfit fest, bis die Schulter mit der Platte bündig ist. Bitte nicht zu fest oder zu schwach anziehen.

IT_MONTAGGIO RAPIDO: Stringere il montaggio rapido fino a quando la spalla è a filo con il pannello, non stringere troppo o troppo poco.

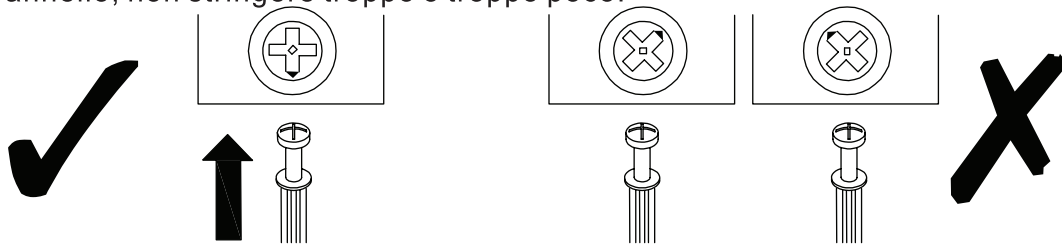

EN_CAM LOCK: When fitting cam lock, ensure starting position is correct before you insert connecting quickfit.

FR_SERRURE BATTEUSE: Avant d'insérer la serrure batteuse, veillez à la bonne orientation avant d'insérer le raccord rapide.

ES_CIERRE DE LA CÁMARA: Cuando instale el cierre de la cámara, asegúrese de que la posición de inicio es correcta antes de que inserte el quickfit conector.

DE_CAM-LOCK: Achten Sie bei der Montage des Cam-Locks auf die richtige Ausgangsposition, bevor Sie den Quickfit einsetzen.

IT_BLOCCAGGIO A CAMMA: Quando si monta il bloccaggio a camma, assicurarsi che la posizione iniziale sia corretta prima di inserire il montaggio rapido di collegamento.

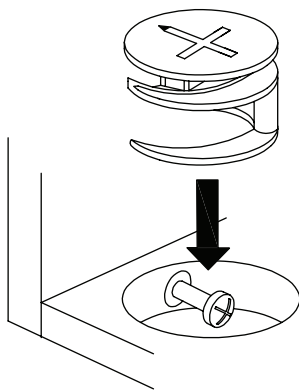

EN_Quickfit head should be in the centre of the cam lock when the two panels are joined.

Cam lock should be inserted before quickfit.

FR_Lorsque les deux panneaux sont assemblés, la tête du raccord rapide doit reposer au centre de la serrure batteuse. Il faut insérer la serrure batteuse avant le raccord rapide.

ES_El cabezal del quickfit debe estar en el centro del cierre de la cámara cuando se unan los dos paneles.

Se debe insertar el cierre de la cámara antes que el quickfit.

DE_Der Quickfit-Kopf sollte sich in der Mitte des Cam-Locks befinden, wenn die beiden Platten zusammengefügt sind. Der Cam-Lock sollte vor dem Quickfit eingesetzt werden.

IT_La testa del montaggio rapido deve trovarsi al centro del bloccaggio a camma quando i due pannelli sono uniti.

Il Bloccaggio a Camma deve essere inserito prima del montaggio rapido.

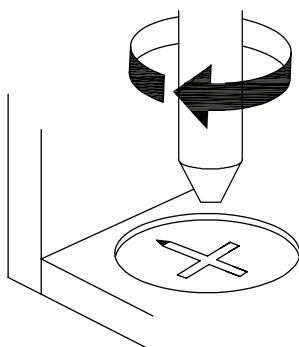

EN_Turn cam lock clockwise to tighten.

FR_Faites tourner la serrure batteuse dans le sens des aiguilles d'une montre pour la resserrer.

ES_Gire el cierre de la cámara en sentido horario para apretarlo.

DE_Drehen Sie den Cam-Lock im Uhrzeigersinn, um ihn festzuziehen.

IT_Ruotare il bloccaggio a camma in senso orario per stringere.

1

A1

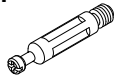

24PCS

B



6 x 30MM

C



36PCS 3.5 x 12MM

E(CL)

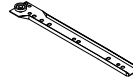

8PCS

E(CR)

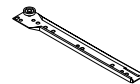

2PCS

2PCS

x 2

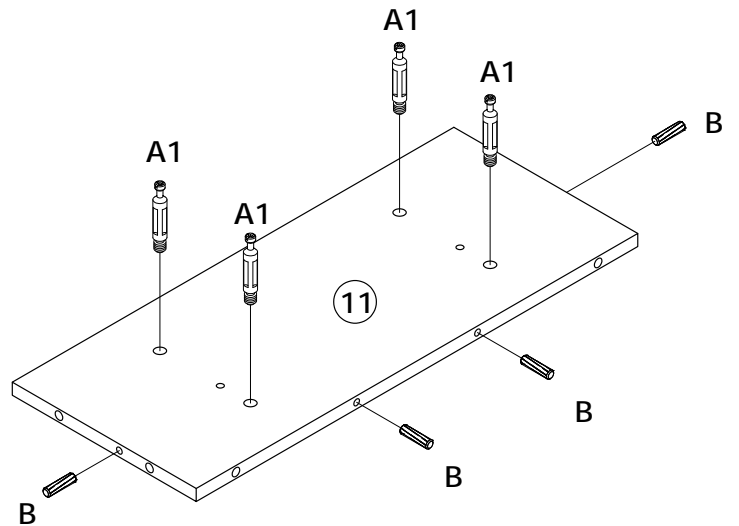
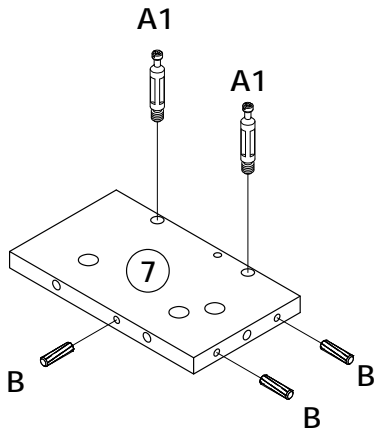
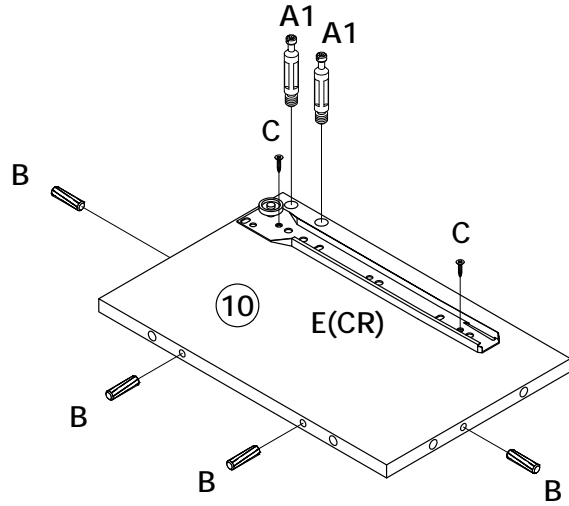
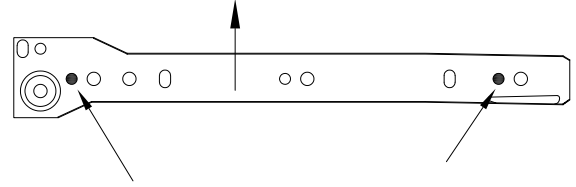
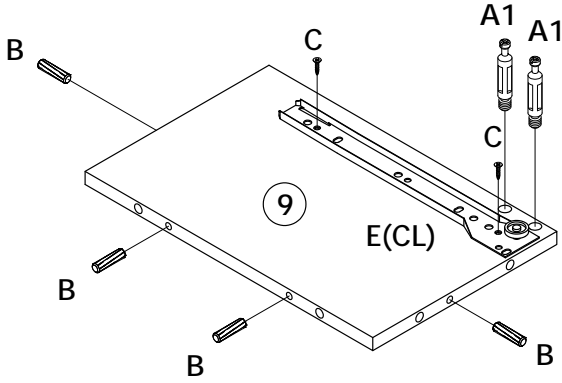

2

A1

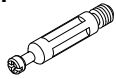

16PCS

B



6 x 30MM

10PCS

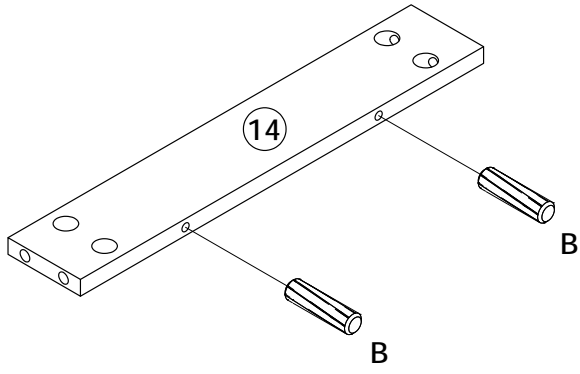

x 4

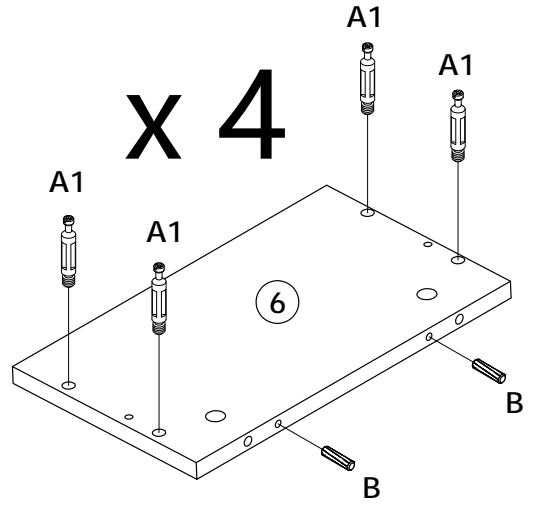

3

A2



16PCS

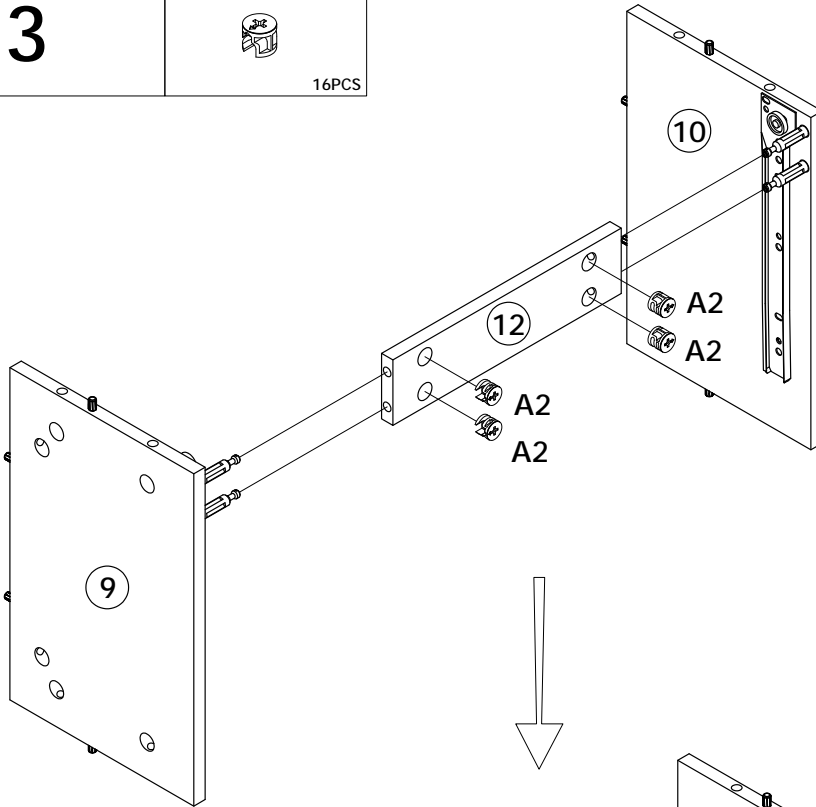

x 2

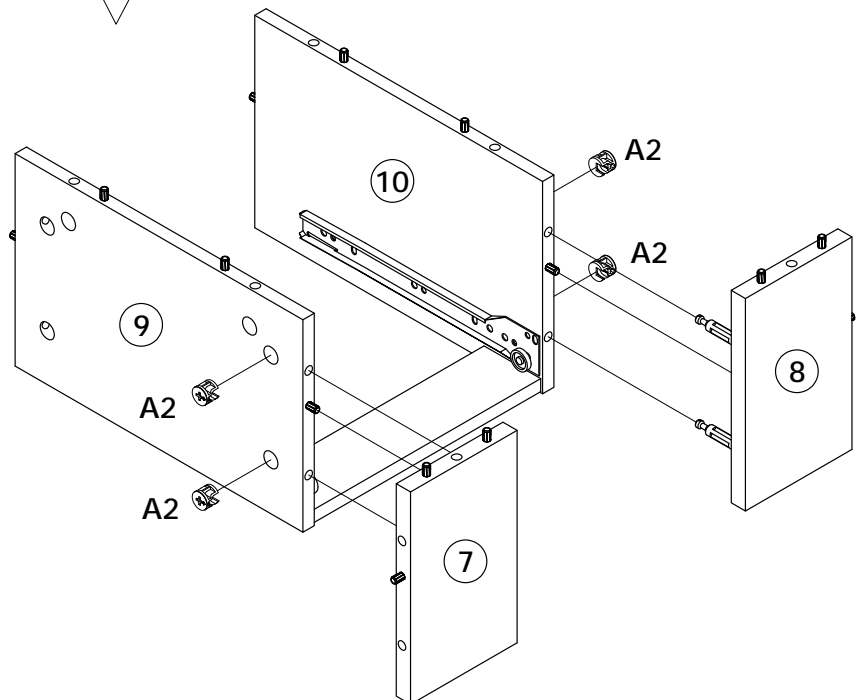

5

A1

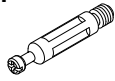

12PCS

C



3.5 x 12MM

8PCS

F1

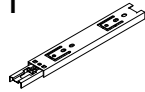

4PCS

x 2

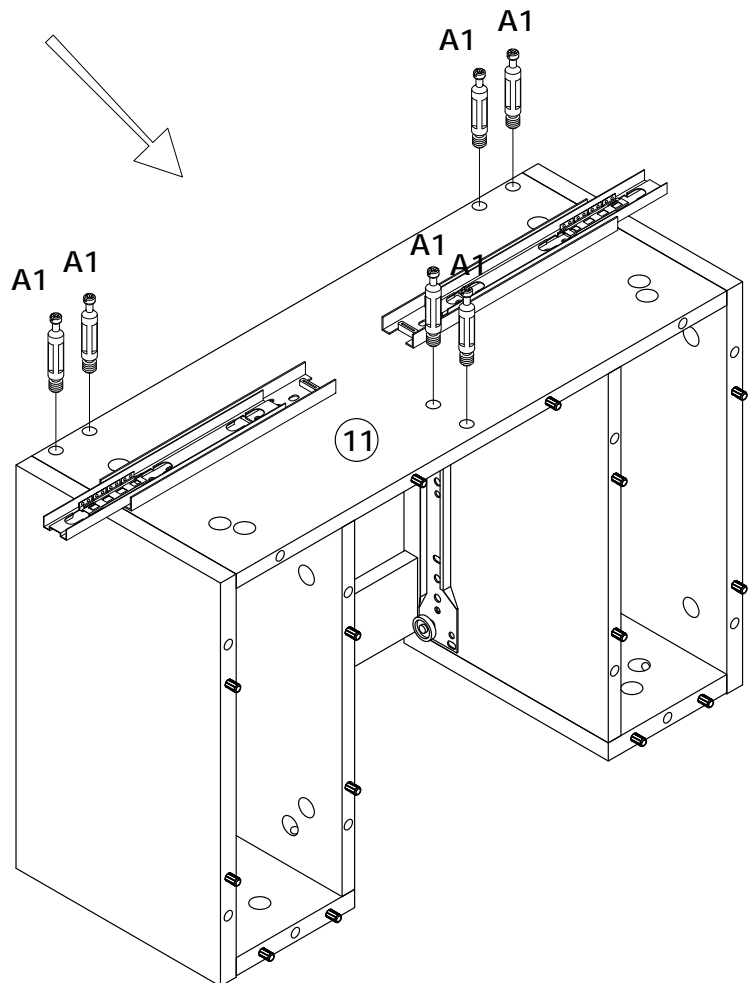
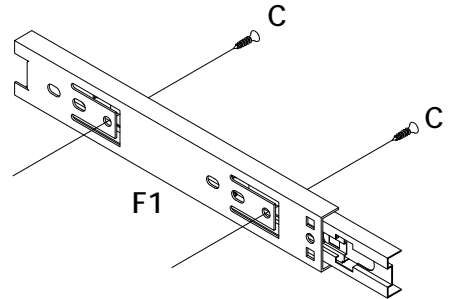
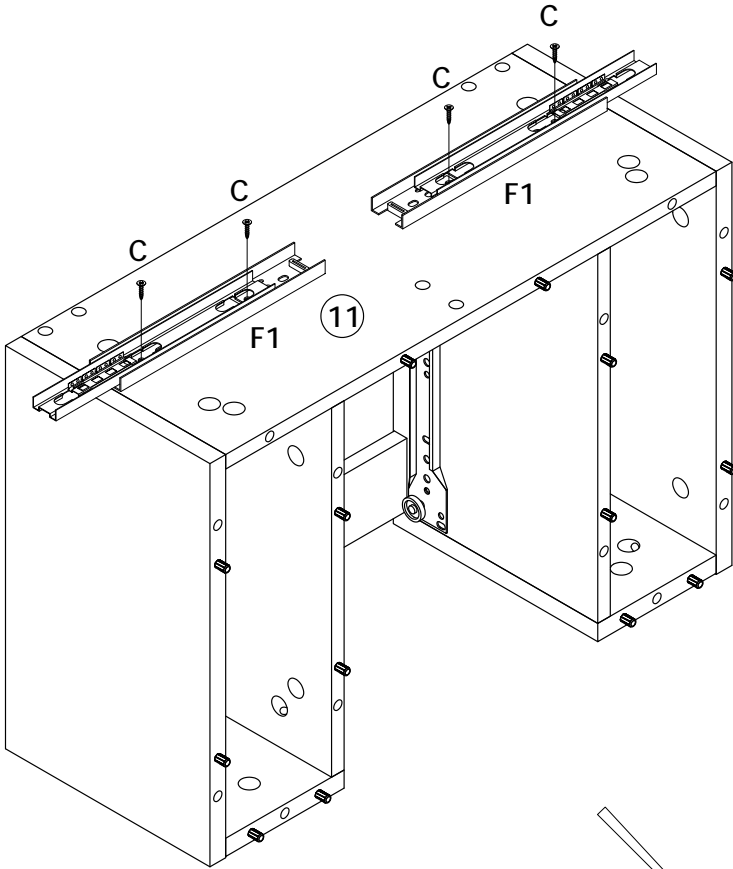

6

A2



12PCS

L



8PCS

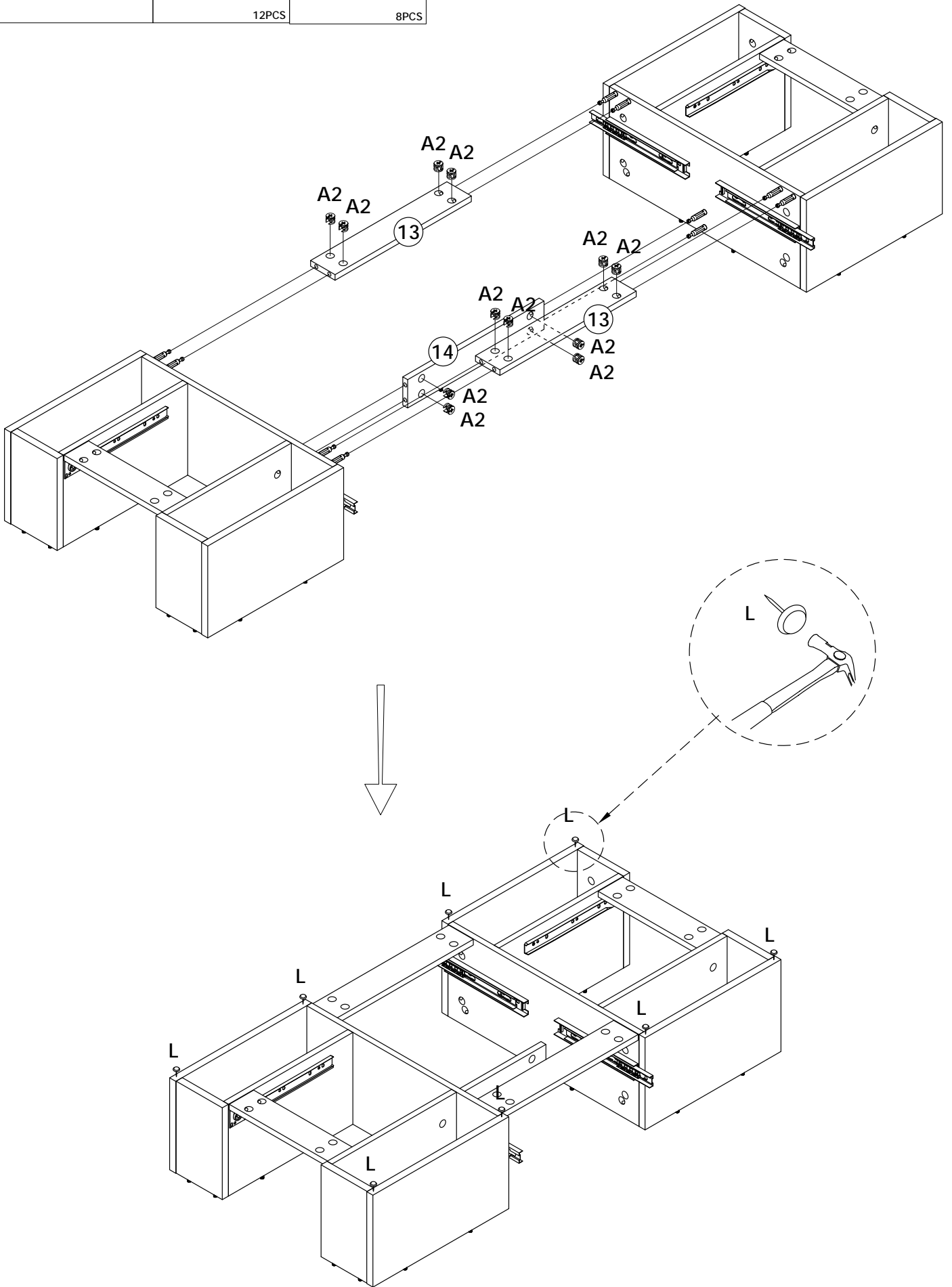

7

A1

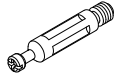

8PCS

B



6 x 30MM

12PCS

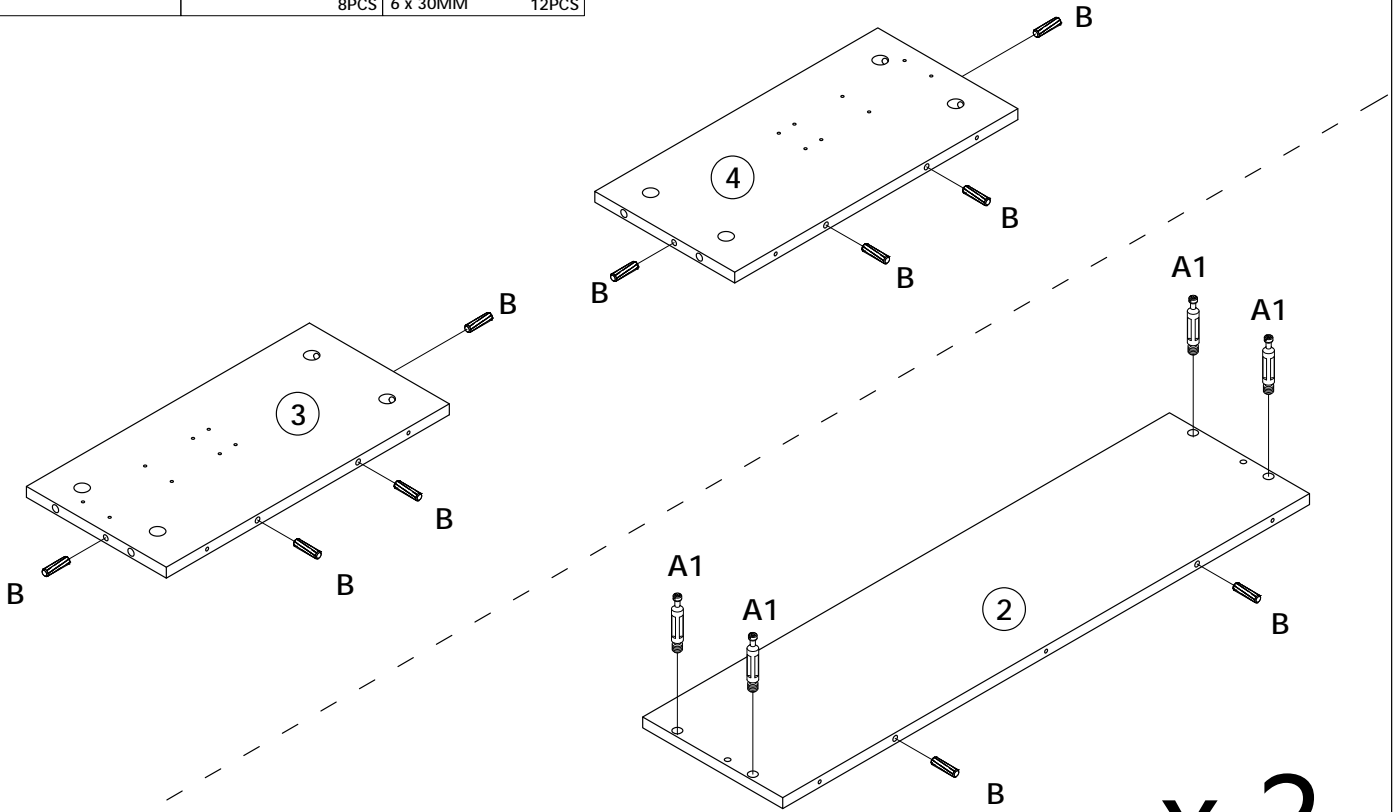

x 2

8

A2



8PCS

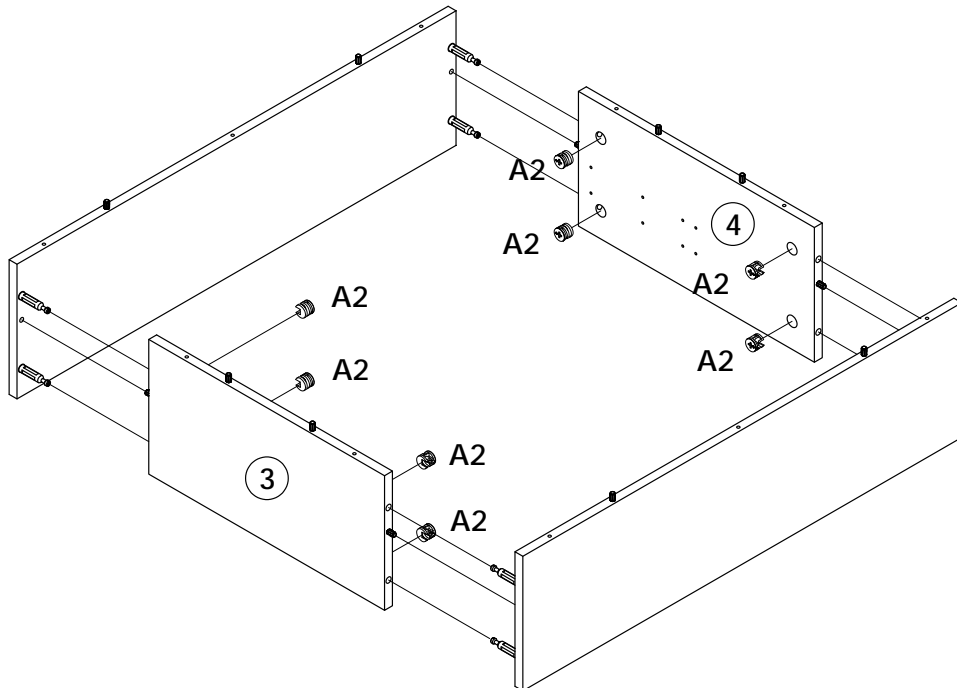

9

A1

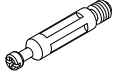

24PCS

G



5 x 40MM

C



3.5 x 12MM

8PCS

H

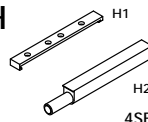

4SETS

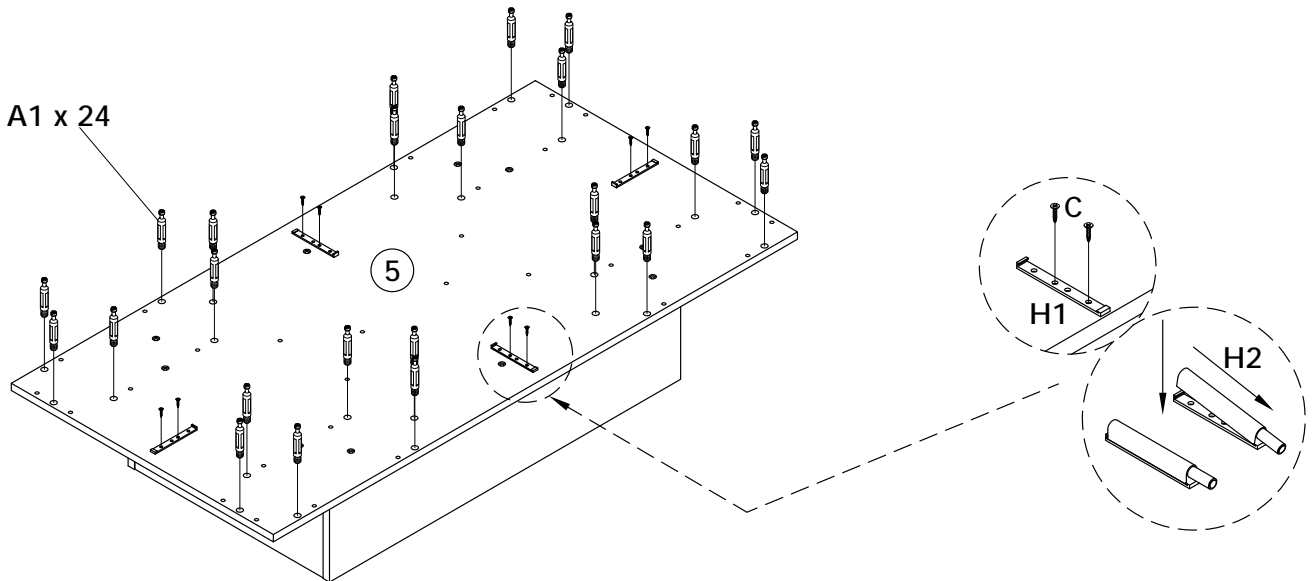
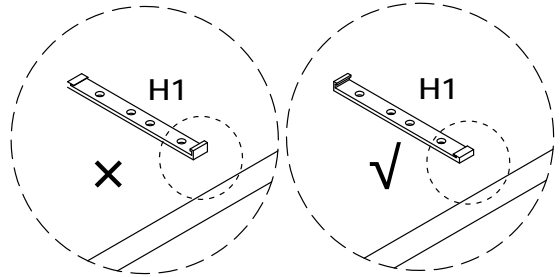
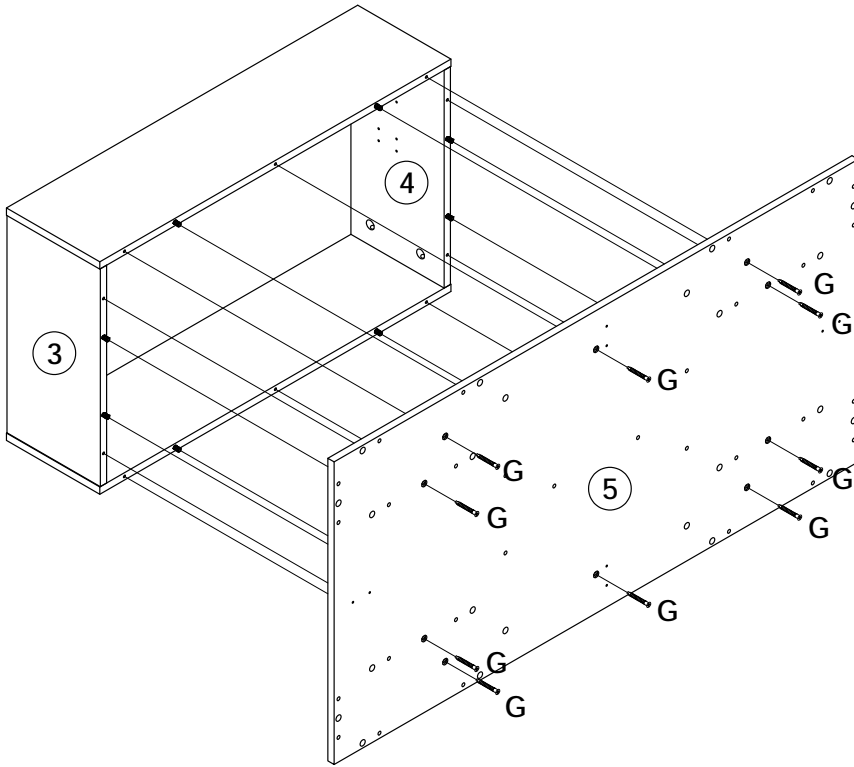

10

A2



24PCS

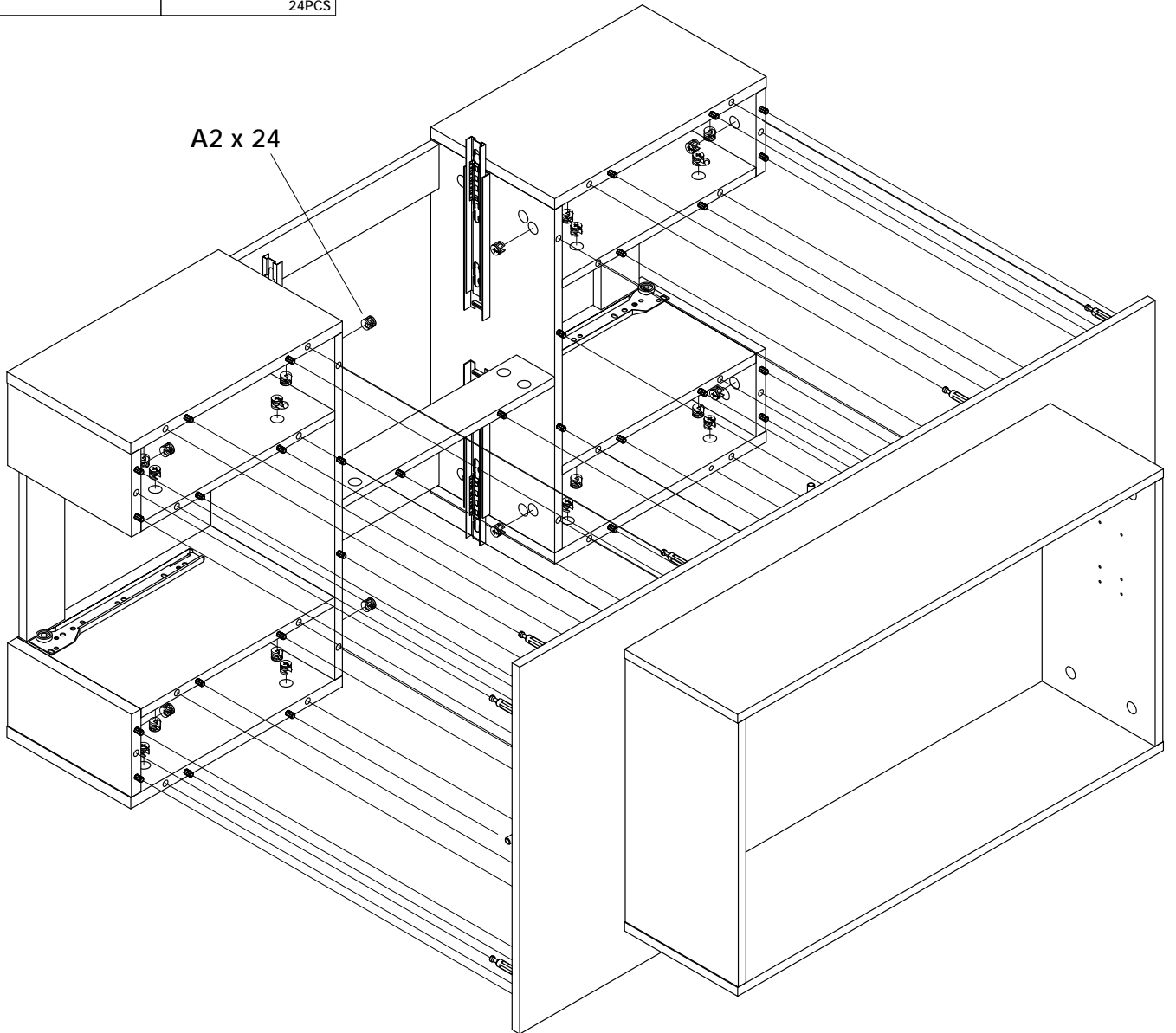

11

D



3.5 x 35MM

8PCS

x 2

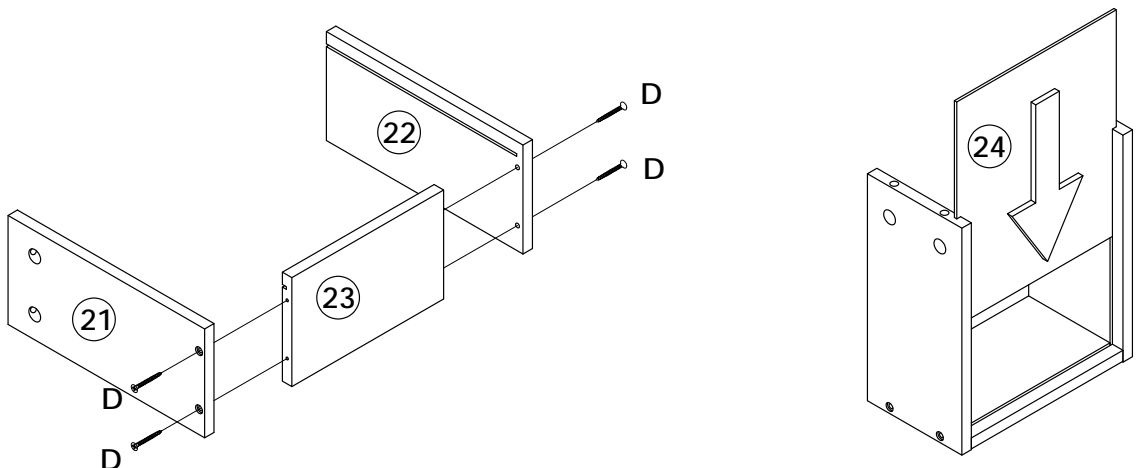

12

A1

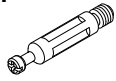

8PCS

A2



8PCS

x 2

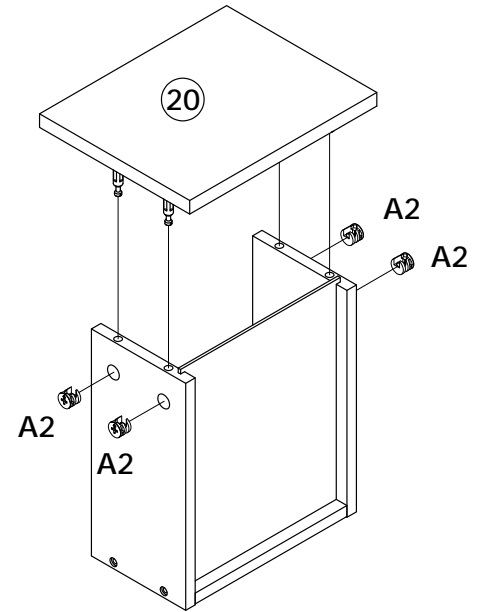
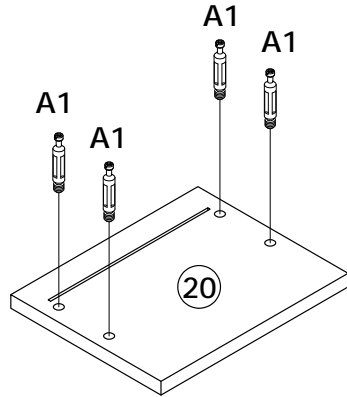

13

C



3.5 x 12MM

8PCS

E(DL)

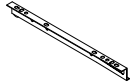

2PCS

E(DR)

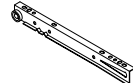

2PCS

x 2

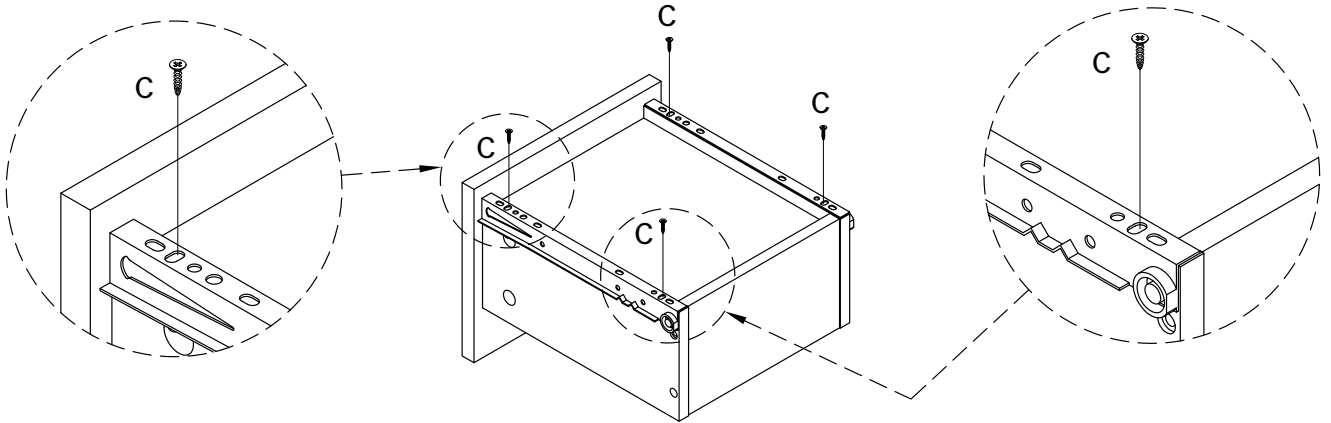

14

D

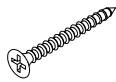

3.5 x 35MM

8PCS

x 2

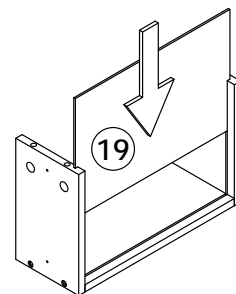
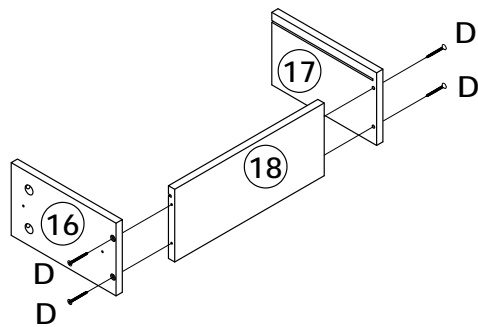

15

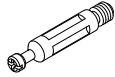
A1

8PCS

A2

8PCS

C

3.5 x 12MM

8PCS

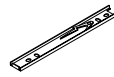
F2

4PCS

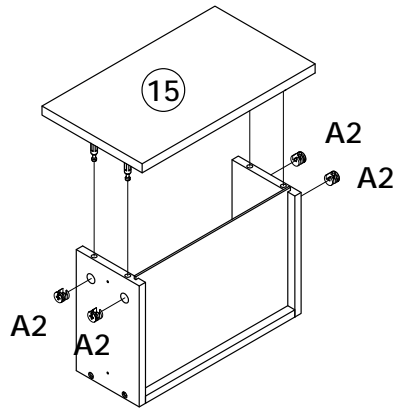
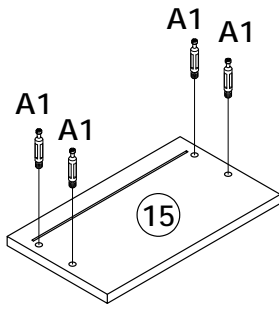

x 2

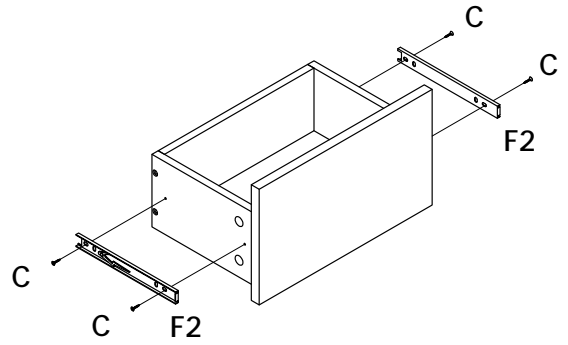
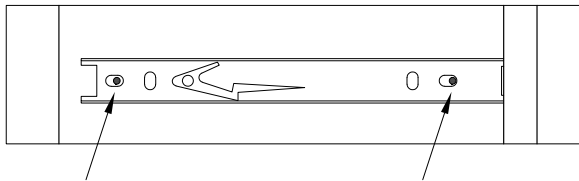

16

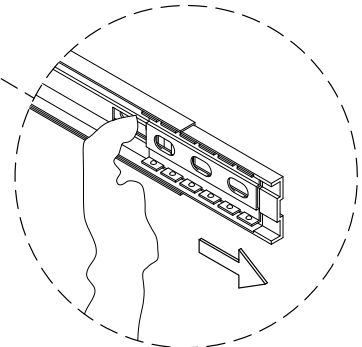
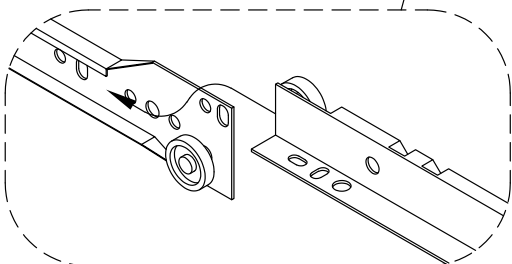
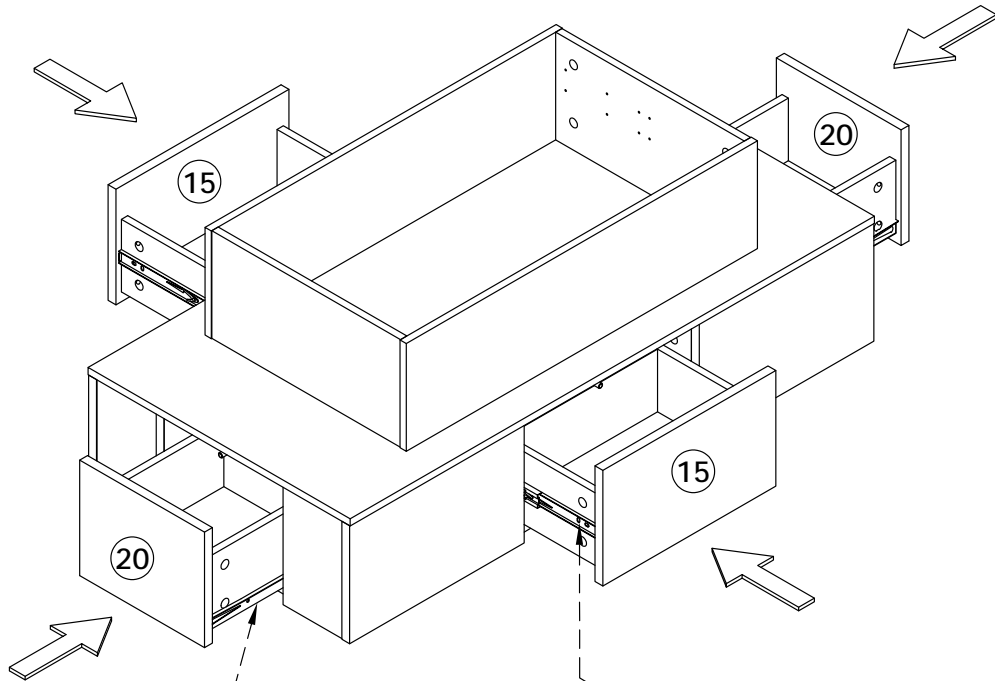

17

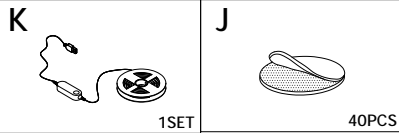

EN:Scan to download App control the Led light.

DE:Scannen, um die App zum Steuern des LED-Lichts herunterzuladen

FR:Scanner pour télécharger App contrôler la lumière Led.

ES:Analice para descargar la aplicación control de la luz Led.

IT:Scansiona per scaricare l' applicazione controlla la luce Led.

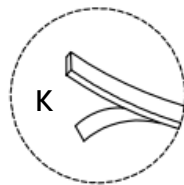
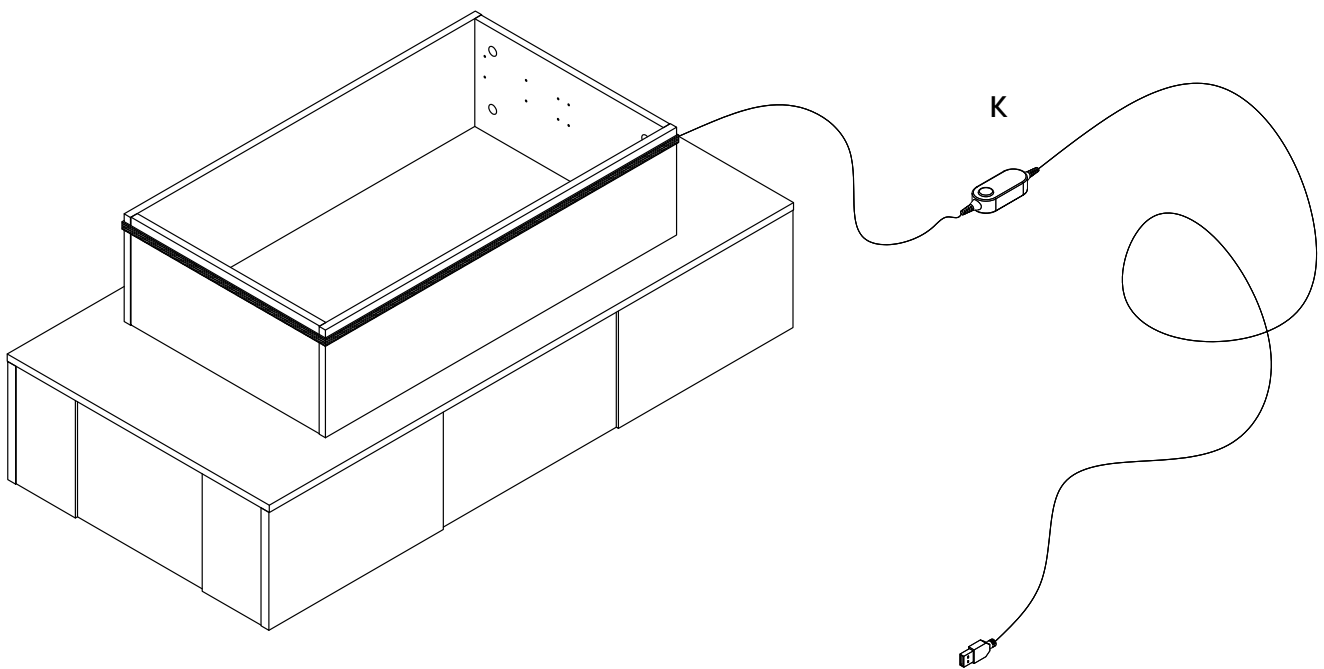

EN:Tear off the back tape

DE:Das Klebeband auf der

Rückseite abziehen FR:Retirez le

ruban adhésif arrière

ES:Quitar la cinta trasera

IT:Strappare il nastro posteriore

EN:In order to make the product more beautiful, please paste hardware J on the exposed holes.

DE:Um ein präzises produkt ästhetisieren zu können,

fügen sie hardware J in eine entblöbte öffnung ein

FR:Afin de rendre le produit plus beau, s' il vous plaît coller le matériel J sur les trous exposés.

IT:Per rendere il prodotto più bello, incollare l' hardware J sui fori esposti.

ES:Con el fin de hacer el producto más hermoso, por favor pega hardware J en los agujeros expuestos

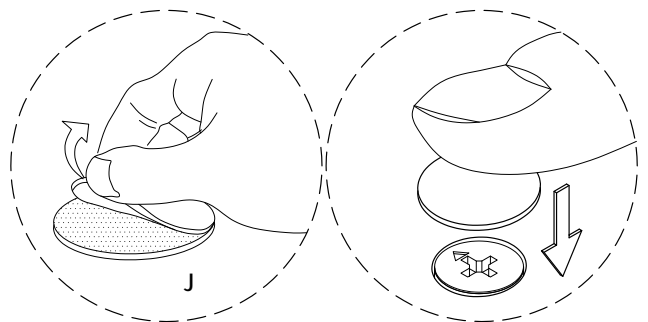

18

C

3.5 x 12MM

12PCS

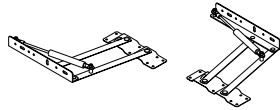
M

1SET

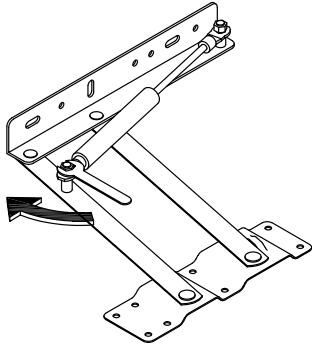
F

Loosen the screws here, as shown.
Lösen Sie die Schrauben hier, wie gezeigt.
Desserrez les vis ici, comme illustré.

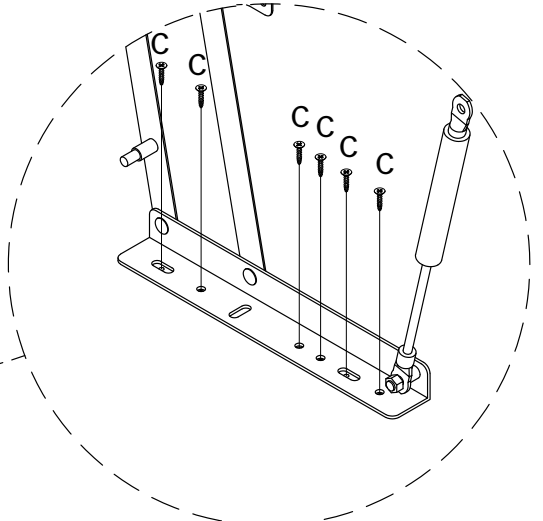

Fix the hardware M firmly on the plate 1 with the self-tapping thread C
Fixieren Sie die Hardware M fest auf der Platte 1 mit dem selbstschneidenden Gewinde C
Fixation ferme de la quincaillerie M sur la plaque 1 avec un filetage autotaraudeur C

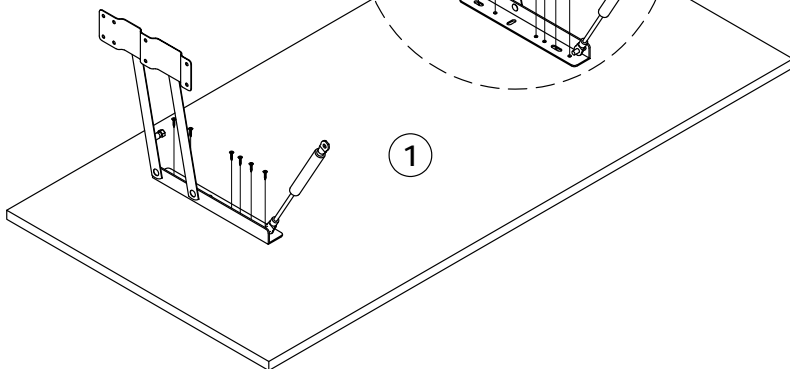
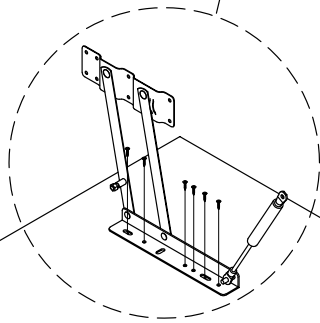
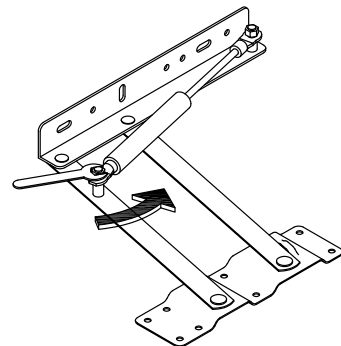
**F**

Tighten the screws on hardware M here.
Ziehe hier die Schrauben an Hardware M an.
Serrez les vis sur le Hardware M ici.

19

C



3.5 x 12MM

16PCS

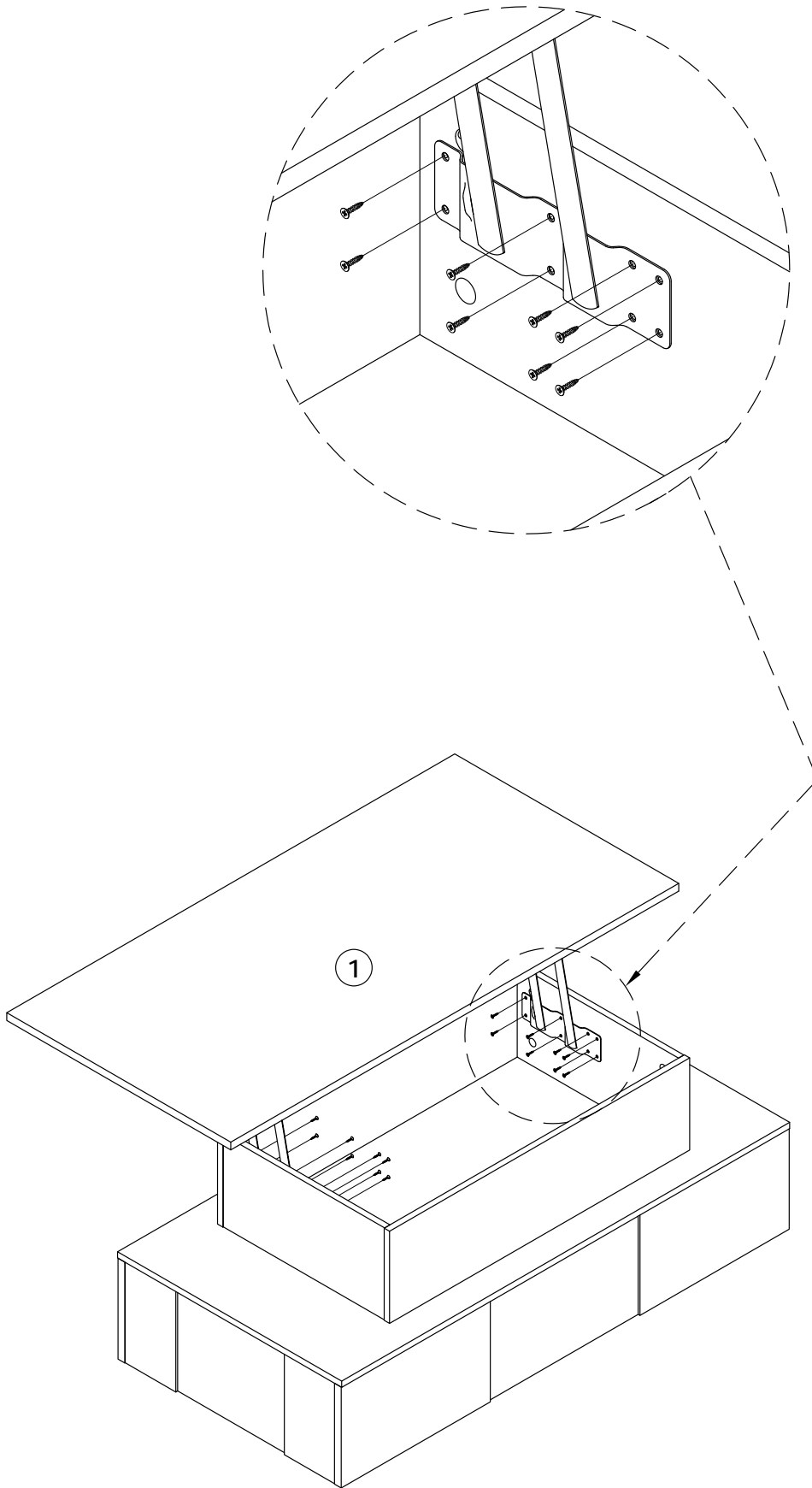

EN:PLEASE NOTE:Part number 1.6.7.8.15.20. is covered with a tight plastic protective film.If there are scratches on the product after disassembly,please don't worry,it's not product damage.Please slowly tear off the protective plastic film on the surface along the edge.After peeling off,the product becomes smooth and clean.

DE:Bitte beachten Sie:TeilNr.1.6.7.8.15.20. sind mit einer dichten Kunststoffschutzfolie abgedeckt. Wenn das Produkt nach der Demontage Kratzer aufweist,machen Sie sich bitte keine Sorgen,es handelt sich nicht um einen Produktschaden.Bitte ziehen Sie die schützende Kunststofffolie auf der Oberfläche entlang der Kante langsam ab.Nach dem Abziehen wird das Produkt glatt und sauber.

FR: Veuillez noter : piece n°1.6.7.8.15.20. sont recouverts d'un film protecteur en plastique dense. Si le produit presente des rayures apres le demontage, ne vous inquietez pas. Il ne s'agit pas d' un dommage au produit. Veuillez retirer lentement le film plastique protecteur sur la surface le long du bord. Apres le decollage, le produit sera lisse et propre.

IT:Nota: parten. 1.6.7.8.15.20. sono ricoperti da una densa pellicola protettiva in plastica. Se il prodotto presenta graffi dopo lo smontaggio, non preoccuparti Non si tratta di un danno al prodotto. Rimuovere lentamente la pellicola di plastica protettiva sulla superficie lungo il bordo. Dopo averla staccata, il prodotto sara liscio e pulito.

ES:Tenga en cuenta: Parte No.1.6.7.8.15.20. Estan cubiertos con una pelicula protectora de plastico densa. Si el producto tiene rayones despues del desmontaje, no se preocupe. Esto no es un dano al producto. Retire lentamente la pelicula protectora de plastico de la superficie a lo largo del borde. Despues de despegarlo, el producto quedara liso y limpio.

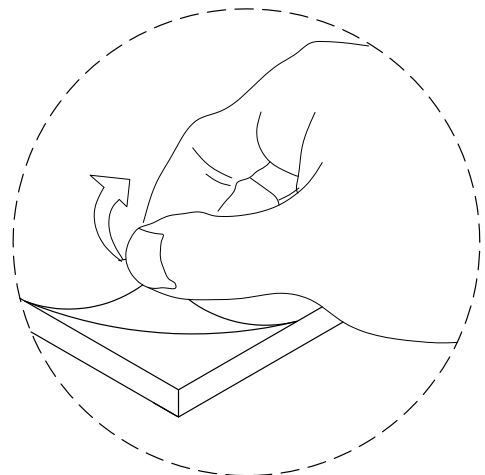
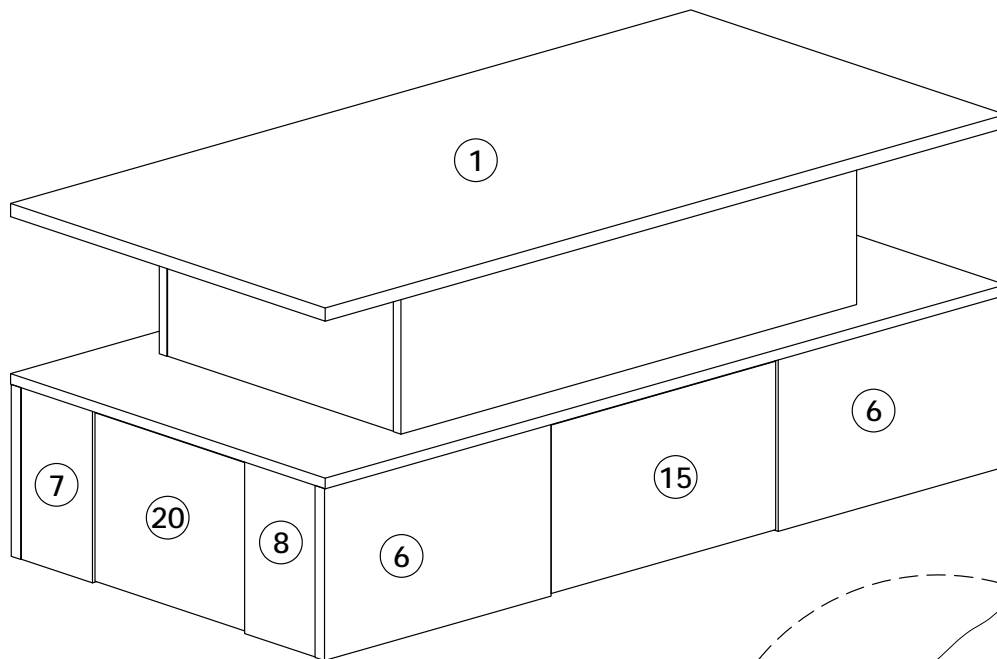

Verification of Compliance

Verification No.:	TMC210319126-E
Name and address of Applicant:	Shenzhen CWG Technology Co., Ltd 5 / F, No.264 Baoshi East Road, Shiyan street, Bao'an District, Shenzhen,China 518108
Name and address of Manufacturer:	Shenzhen CWG Technology Co., Ltd 5 / F, No.264 Baoshi East Road, Shiyan street, Bao'an District, Shenzhen,China 518108
Product name:	LED Strip
Rated:	DC12V
Product model(s):	CWG-5050RGB-60D-12V , additional models reference attachment
Product trademark:	创唯光

This verification confirms that the product meets the requirements of the following standard. The conformity was demonstrated based on following standard(s) listed by European Commission as harmonized with EMC Directive 2014/30/EU.

EN IEC 55015:2019+A11:2020
IEC 61547:2020

The verification has been carried out in accordance with individual rules and conditions agreed with the applicant. Evaluation has been carried out in accordance with:

Test report(s) No.:	TMC210319126-E
Test conducted by:	TMC Testing Services (Shenzhen) Co., Ltd.
Verification issue date:	March 26, 2021

Notes:

This verification refers to the above mentioned product and its conformity in regards of above mentioned standard(s) was proven on test sample.

This verification does not imply meeting all essential requirements, assessment of the series-production or any other restricted Notified Bodies conformity assessment procedure appropriate for the product.

This verification holder shall use this verification in connection to verification of conformity and technical data relevant for the product the verification was issued.

TMC Testing Services (Shenzhen) Co., Ltd.

t:86-755-86642861 cert@tmc-lab.com www.tmc-lab.com

1st Floor, Block A1, Zone A, Xinshidai Gongrong Industrial Park, No. 2, Shihuan Road, Shiyan Street, Baoan District, Shenzhen, China



Verification of Compliance

CWG-5050RGB-30D-12V, CWG-5050RGB-18D-12V, CWG-5050RGB-60D-24V,
CWG-5050RGB-60D-5V, CWG-5050RGB-30D-5V, CWG-5050RGB-18D-5V,
CWG-5050-60D-12V, CWG-5050-30D-12V, CWG-5050-60D-24V,
CWG-HC5050RGB-60D-12V, CWG-HC5050RGB-30D-12V,
CWG-HC5050RGB-60D-24V, CWG-HC5050-60D-12V, CWG-HC5050-30D-12V,
CWG-HC5050-60D-24V, CWG-HC5050RGB-30D-5V, CWG-HC5050RGB-60D-5V,
CWG-HC5050RGB-144D-5V, CWG-2835-60D-12V, CWG-2835-120D-12V,
CWG-2835-60D-24V, CWG-2835-120D-24V, CWG-2835-60D-5V, CWG-2835-120D-5V

Note:

This attachment only valided with Verification No.: TMC210319126-E