

# QUEEN BED



**Platform Bed**



Estimated Time for Assembly

**45:00 - 60:00**



Weight Limitation

**600 lbs**

Tools Needed

**All necessary tools are included in the package.**

(Phillips Screwdriver Not Included)

## **CAUTION:**

Do not attempt to move the bed when fully assembled. This could result in damage to the rails, headboard, or footboard.

When placing furniture on non-carpeted flooring, we recommend the use of floor protection such as an area rug or furniture pads. Area rugs and padding not included with purchase.

***PLEASE CONTACT US FOR QUESTIONS***

---

Bed Parts are shipped inside a compartment  
in the back of the headboard.

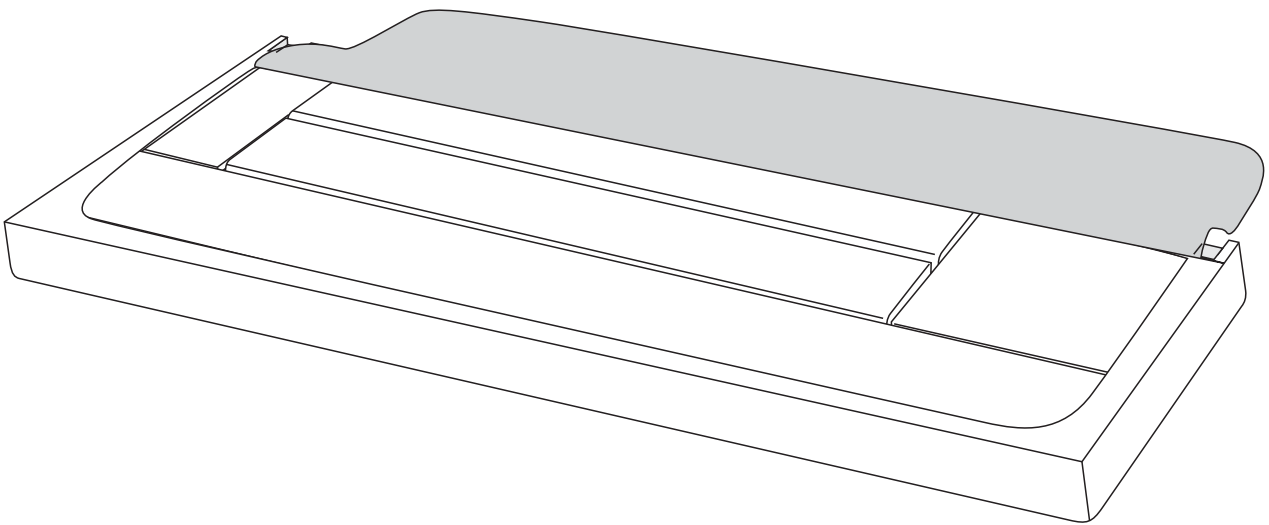

***PLEASE CONTACT US FOR QUESTIONS***

---

**Remove parts from headboard compartment**

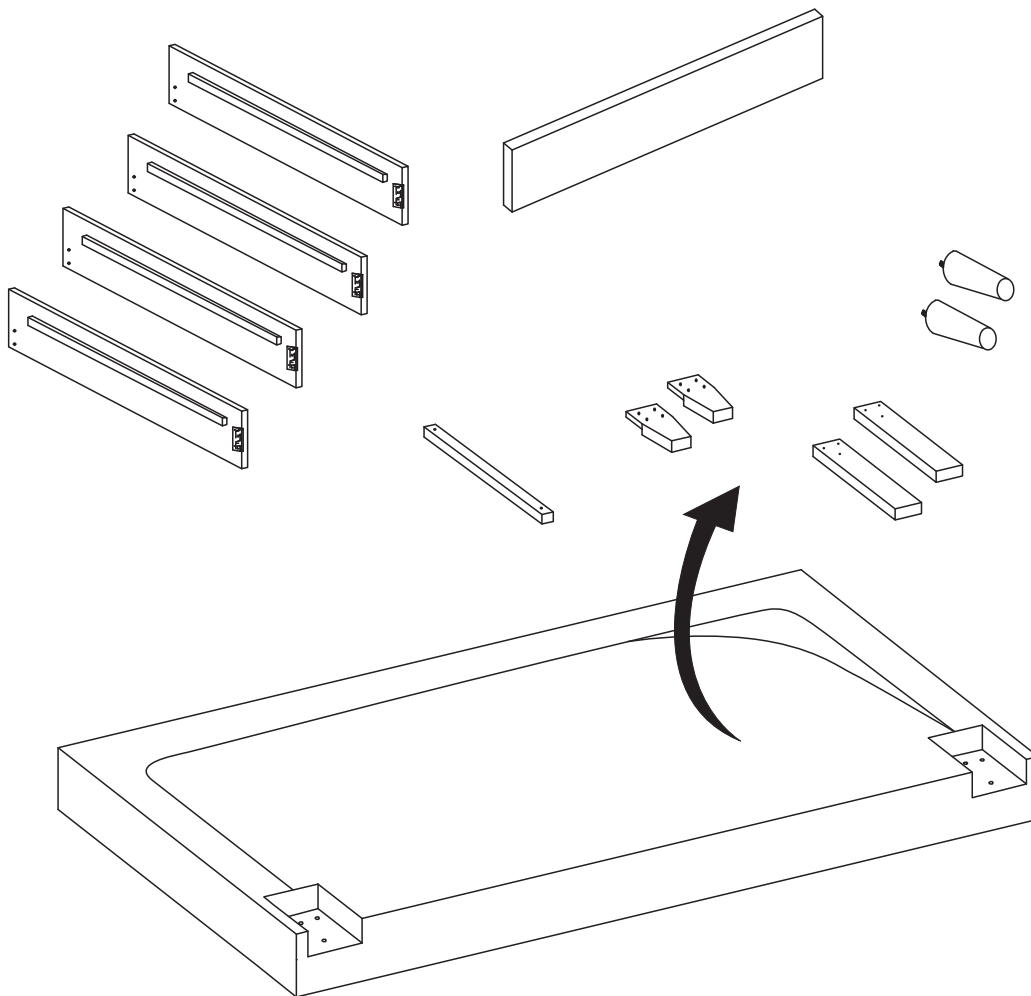

# PACKAGE CONTENT

**CAUTION:**  
DO NOT SLIDE BED AFTER  
ASSEMBLY. LIFT THE BED FRAME  
INTO ITS FINAL POSITION.

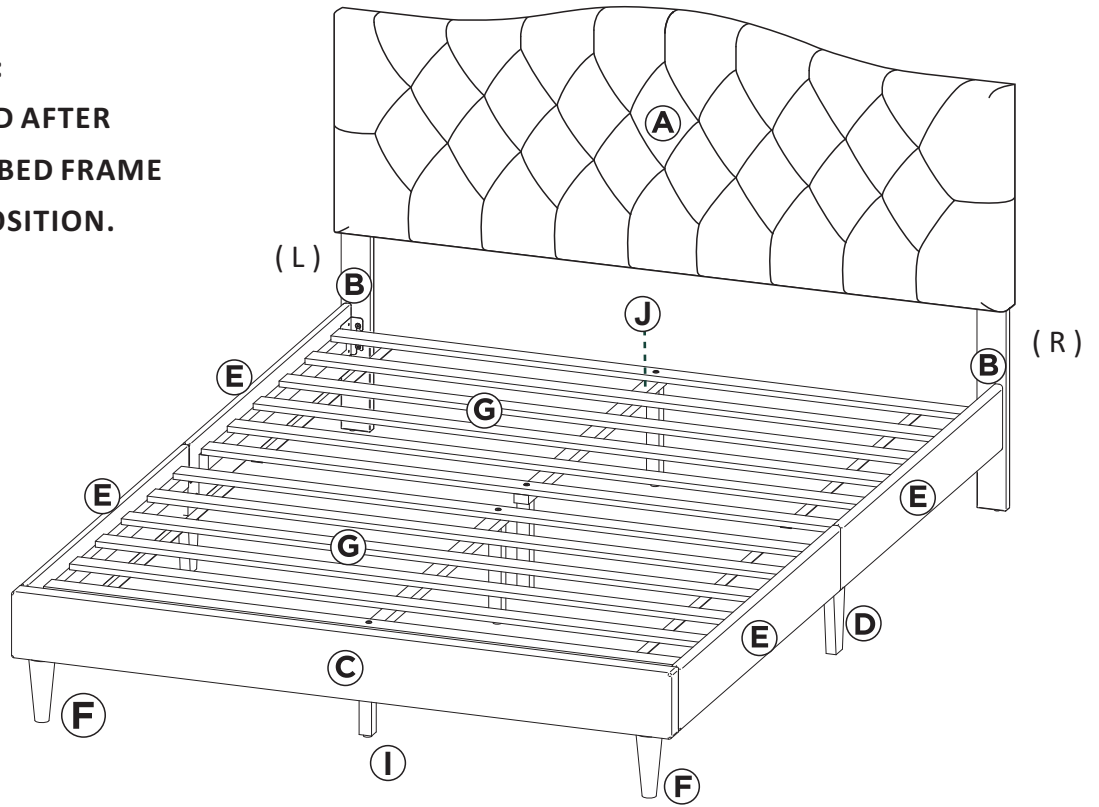

QUEEN BED

## Components

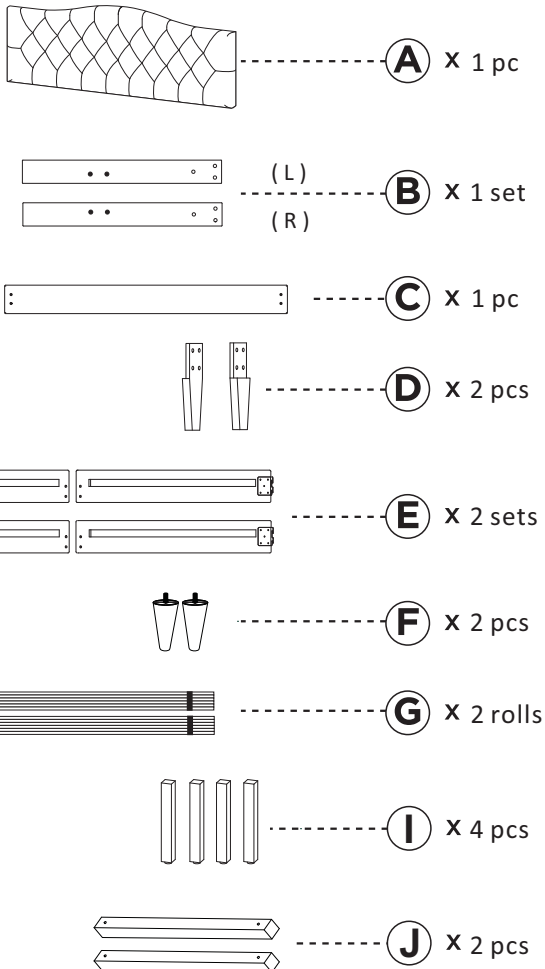

## Hardware

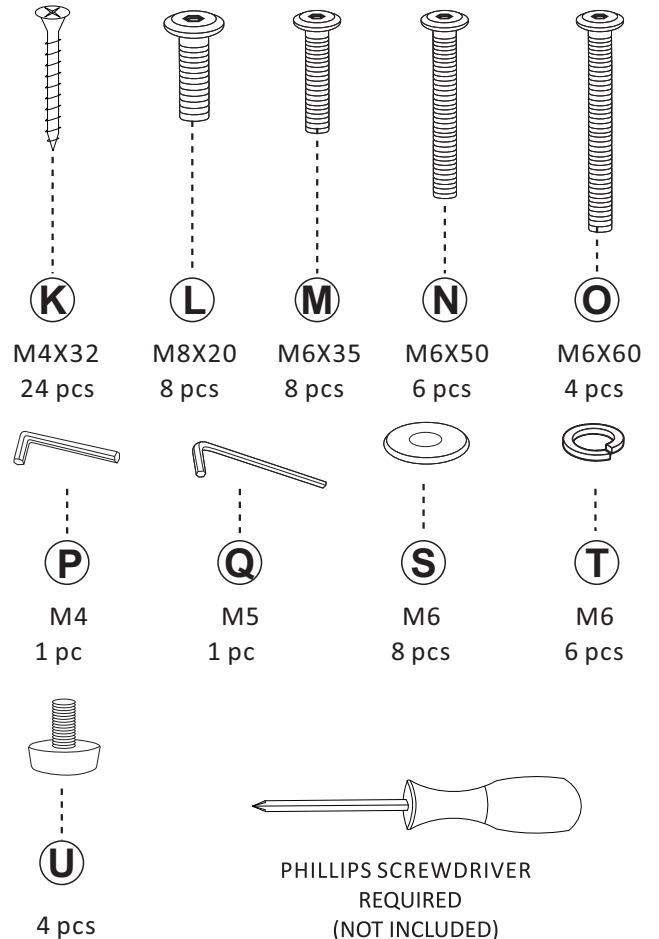

1.

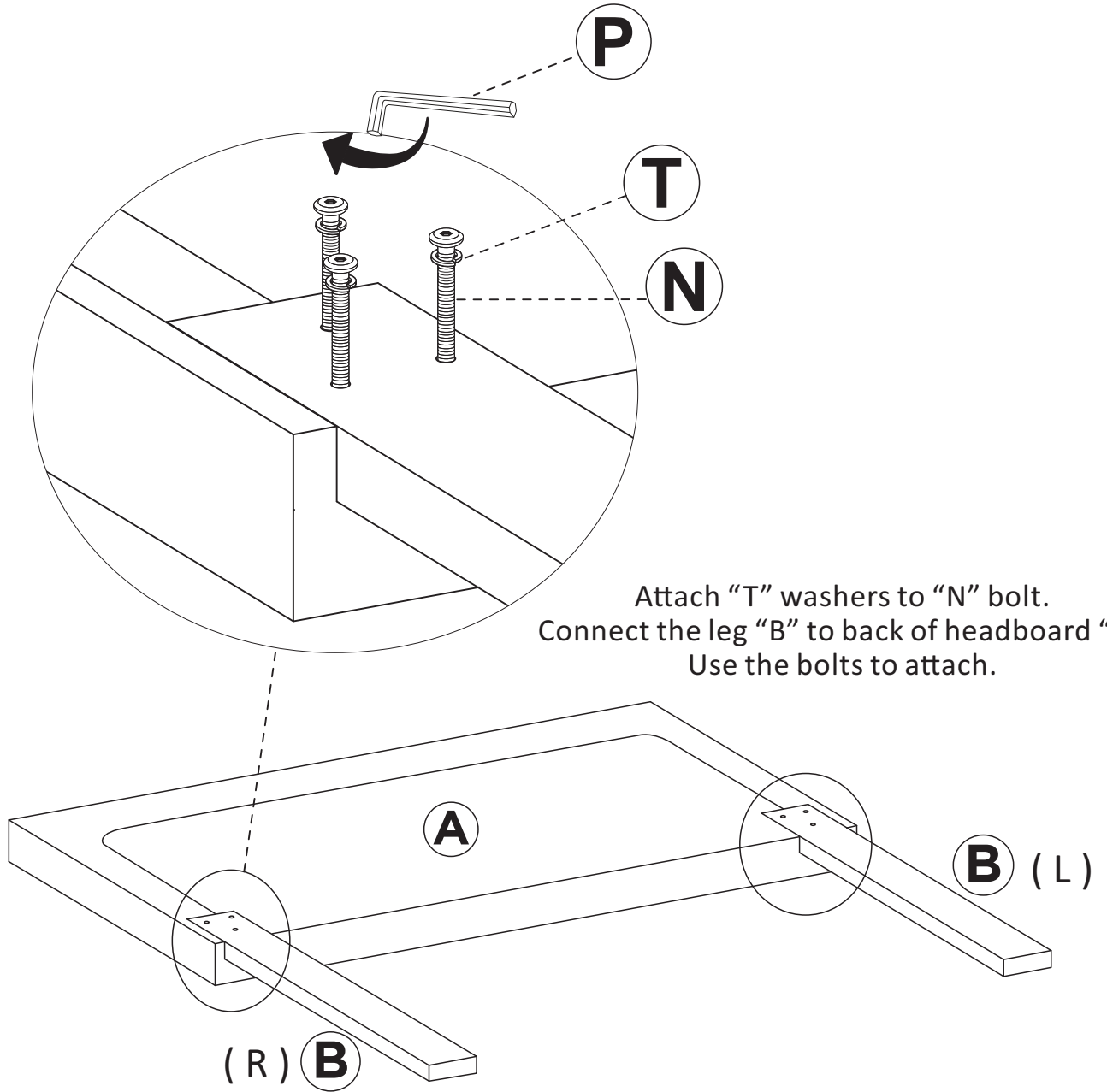
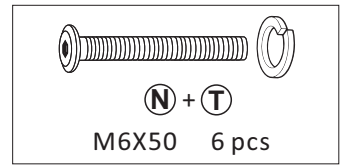

2.

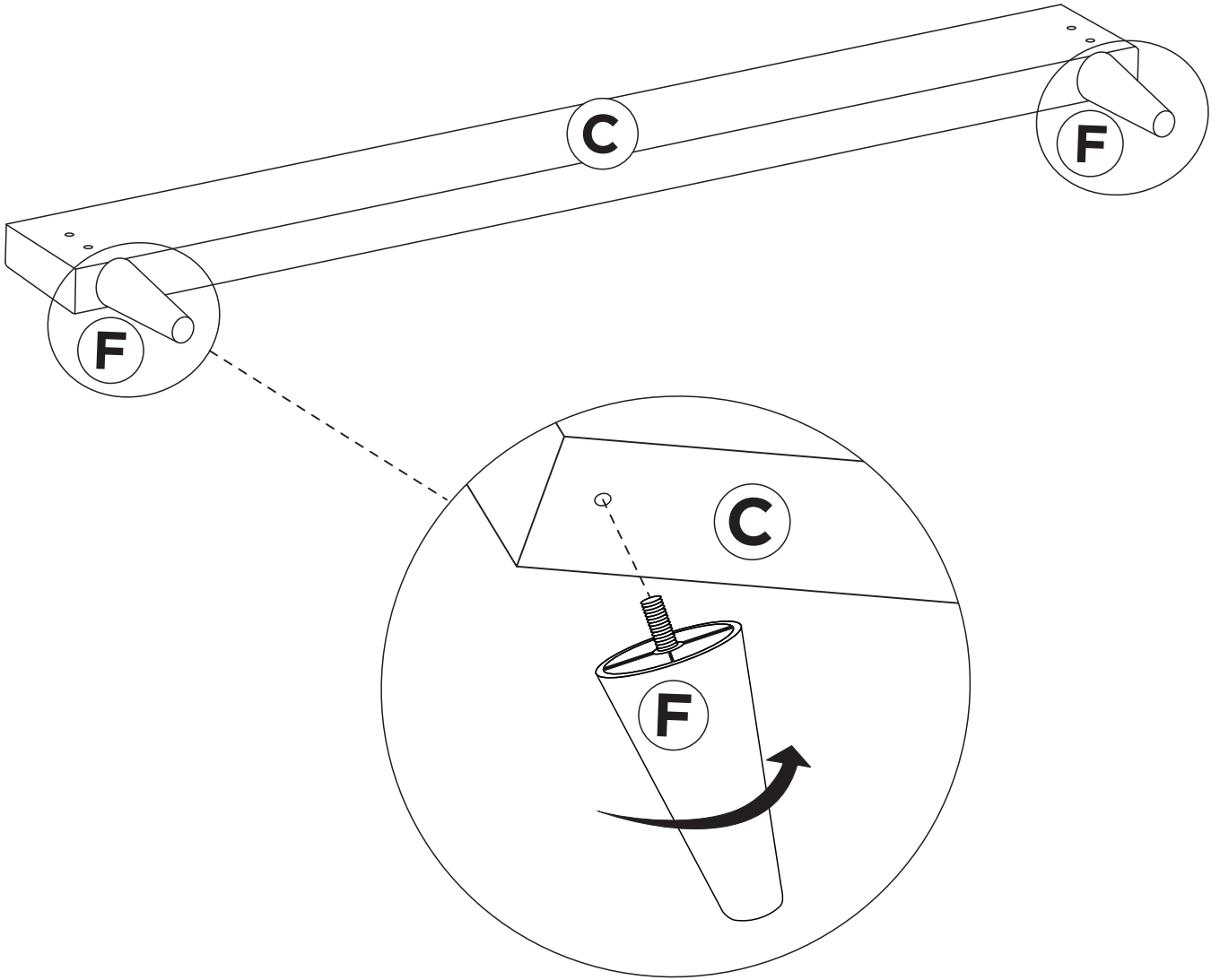

# 3.

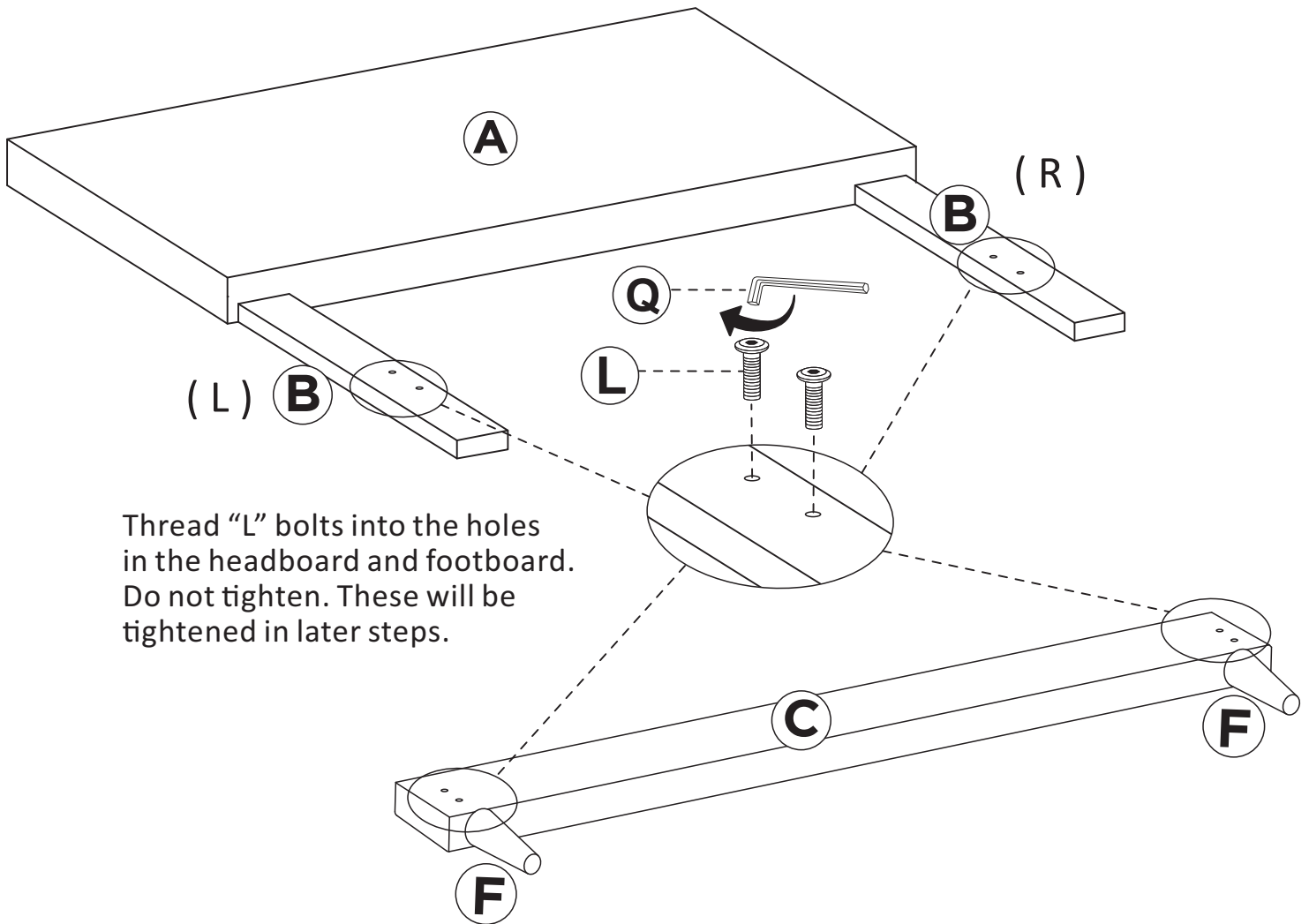
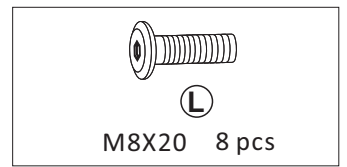

4.

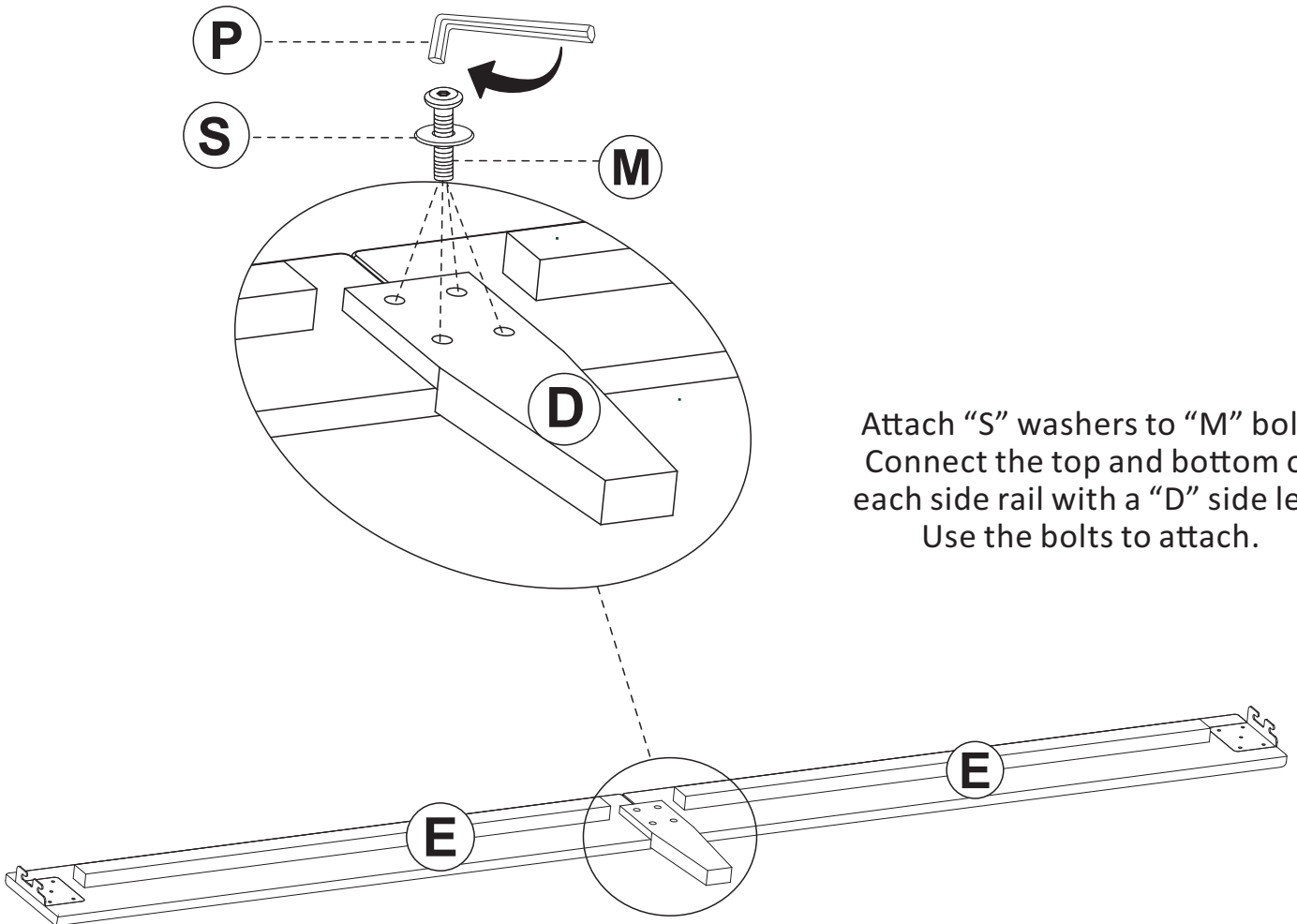
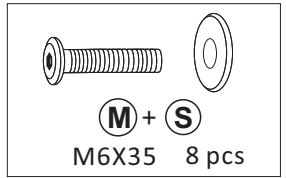

Attach "S" washers to "M" bolt.  
Connect the top and bottom of  
each side rail with a "D" side leg.  
Use the bolts to attach.

**Same assembly steps to the second set of side rail.**

# 5.

Hang the hooks at the ends of the side rails onto the "L" bolts in the headboard leg and the footboard. Do not fully tighten the "L" bolts. The bolts will be tightened in a later step.

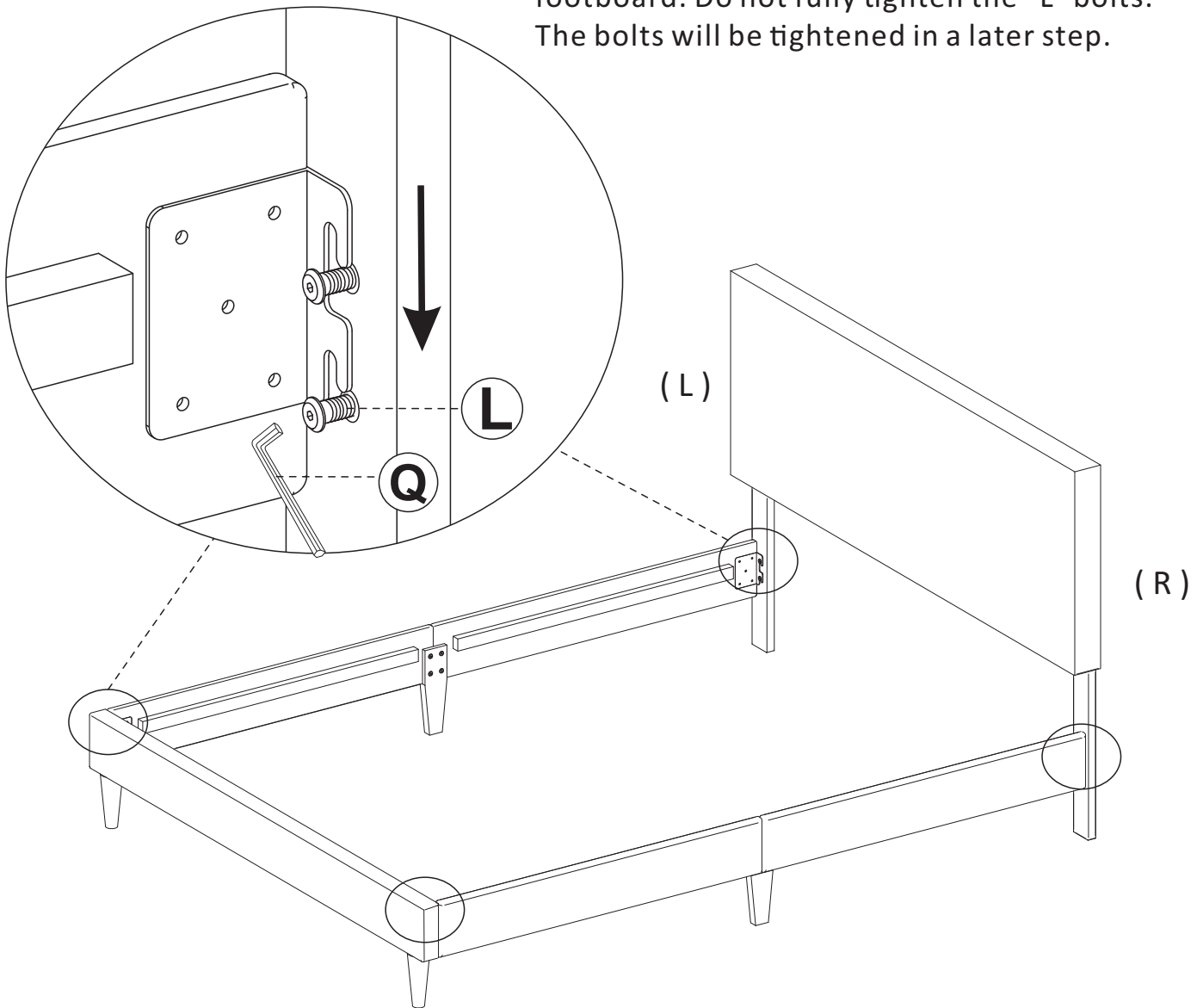

6.

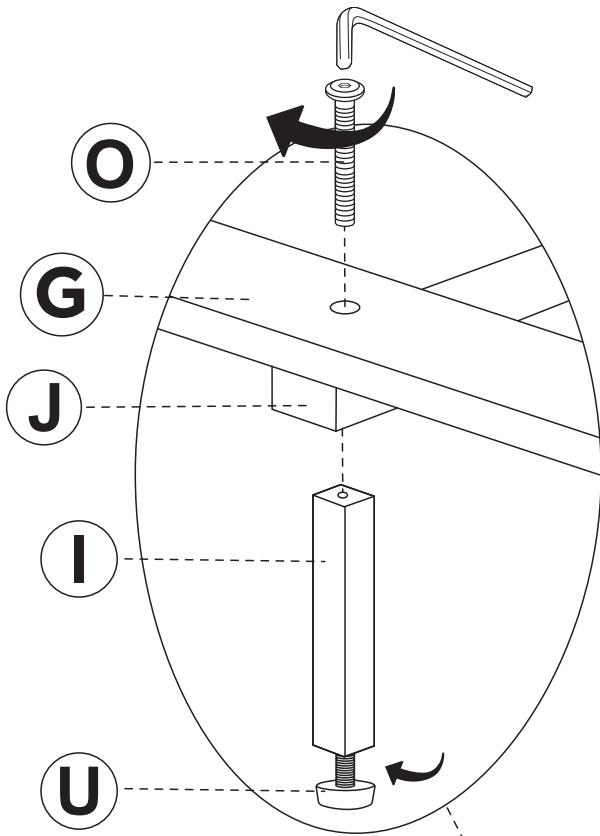
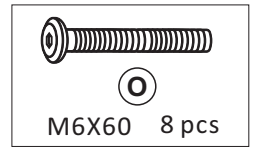

Attach adjustable leveling feet "U" to the bottom of leg "I". Then assemble the slat system by attaching the slats "G" to the "J" supports and "I" legs. First, extend the slats. Then, line up the holes in the slats with the holes in the "J" supports and the holes in the tops of the "I" legs. Use an "O" bolt through the holes to attach them together.

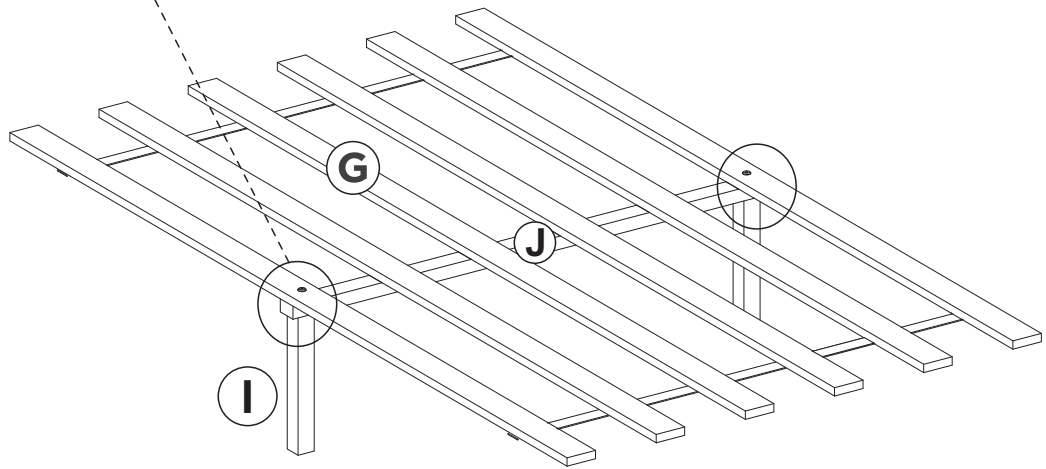

**Same assembly steps  
to the second roll slat**

After the slat system is assembled, place the slats into the frame of the bed as shown next page.

7.

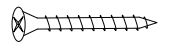

(K)

M4X32 24 pcs

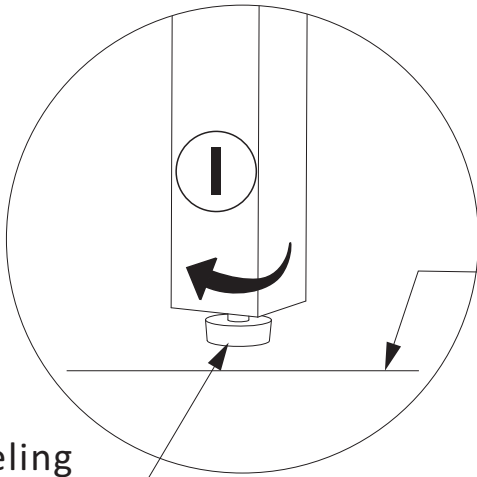

Then, adjust slat leveling feet on the bottom of leg "I" to a distance 1/2" above the floor.

Floor line

Leveling feet "U"

Then, use screwdriver to install "K" screws into side rail cleat

(K)

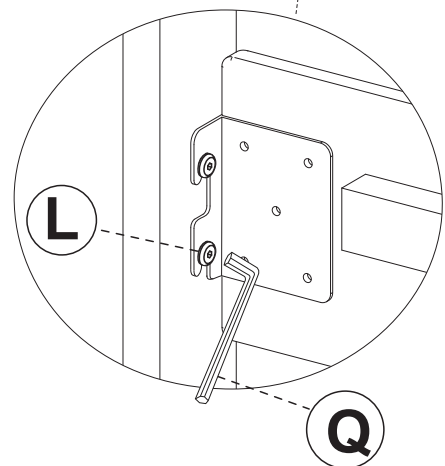
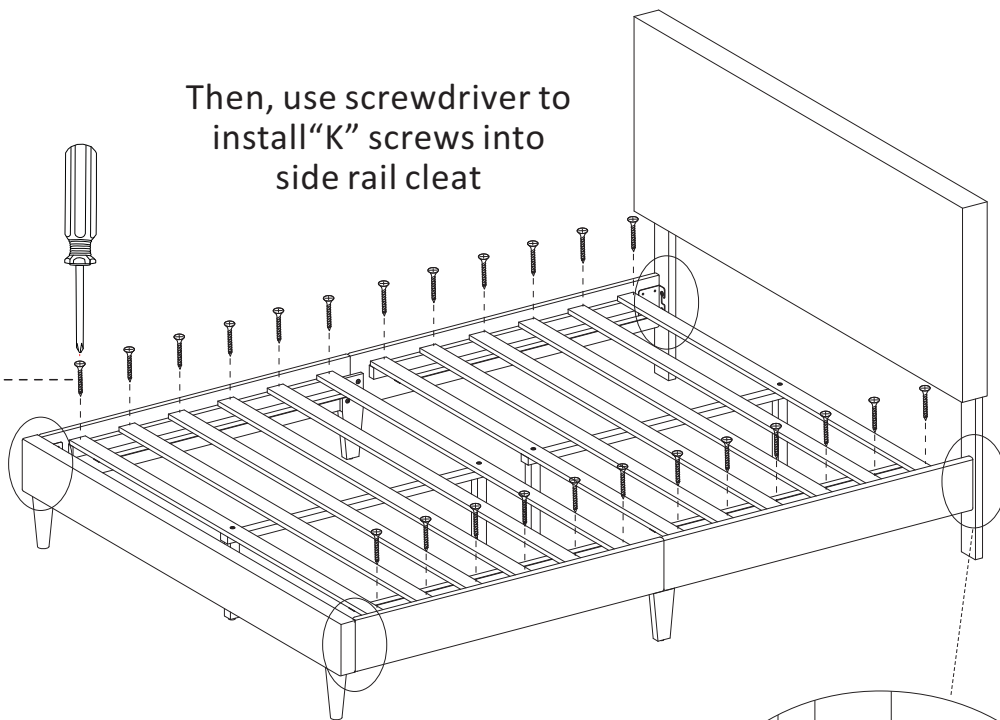

Finally, tighten all "L" bolts.

(Q)

**FINISH !**