

ASSEMBLY INSTRUCTIONS

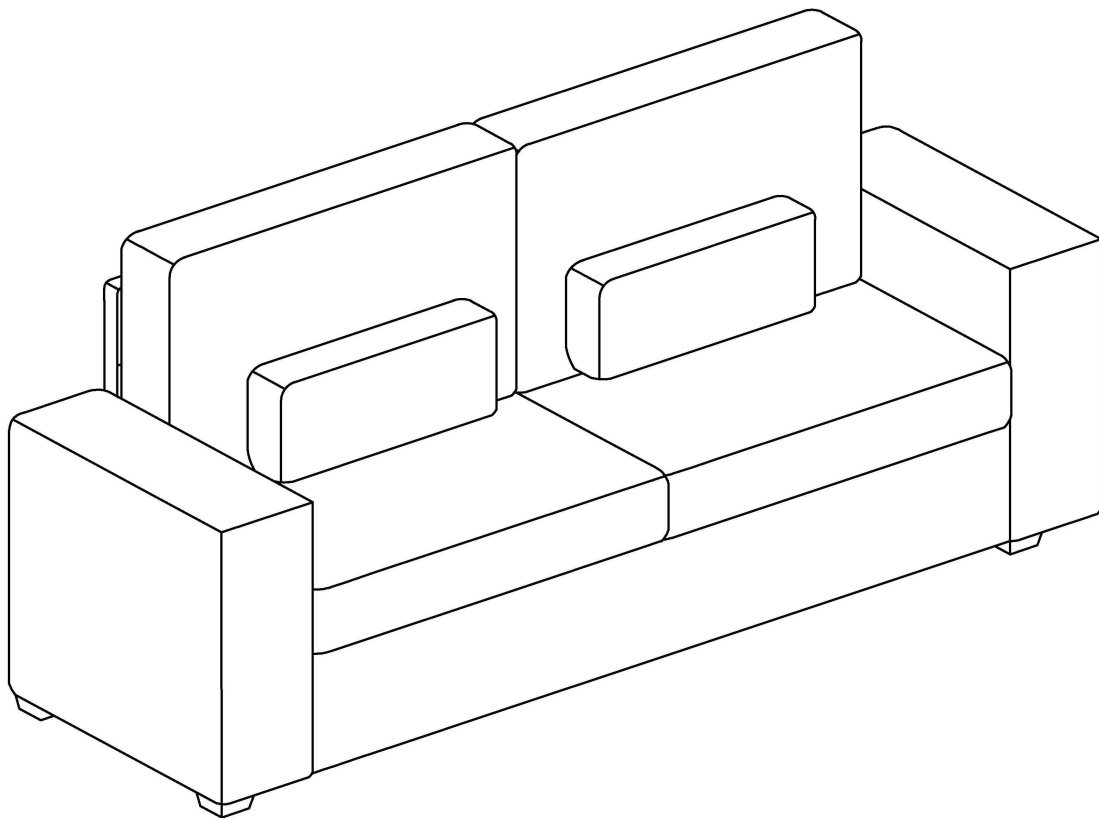

BOX 1

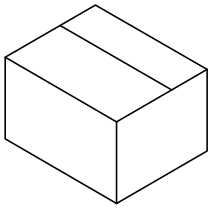

PARTS LIST





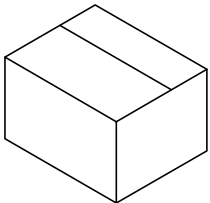





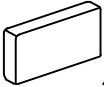

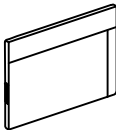
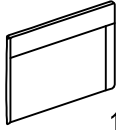
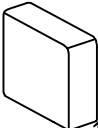
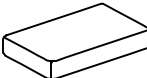
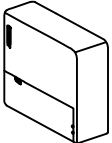



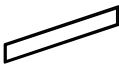

| | | | | | |
|---|--|----|---|--|----|
| Ⓒ | | x1 | Ⓘ | | x1 |
| Ⓓ | | x1 | ⓵ | | x1 |
| Ⓕ | | x2 | Ⓚ | | x1 |
| Ⓗ | | x1 | Ⓛ | | x1 |

BOX 2



PARTS LIST

| | | | | | | | | |
|---|--|----|---|--|-----|----|--|----|
| Ⓐ | | x2 | 1 | | x4 | 7 | | x4 |
| Ⓑ | | x2 | 2 | | x1 | 8 | | x4 |
| Ⓔ | | x1 | 3 | | x24 | 9 | | x1 |
| Ⓖ | | x1 | 4 | | x1 | 10 | | x1 |
| | | | 5 | | x1 | 11 | | x4 |
| | | | 6 | | x1 | 12 | | x4 |

| | | | | | | | | | | | |
|---|---|---|---|---|--|----|--|----|---|----|---|
| A |  2PCS | B |  2PCS | C |  1PC | D |  1PC | E |  1PC | F |  2PCS |
| G |  1PC | H |  1PC | I |  1PC | J |  1PC | K |  1PC | L |  1PC |
| 1 |  4PCS | 2 |  1PC | 3 |  24PCS | 4 |  1PC | 5 |  1PC | 6 |  1PC |
| 7 |  4PCS | 8 |  4PCS | 9 |  1PC | 10 |  1PC | 11 |  4PCS | 12 |  4PCS |

STEP 1

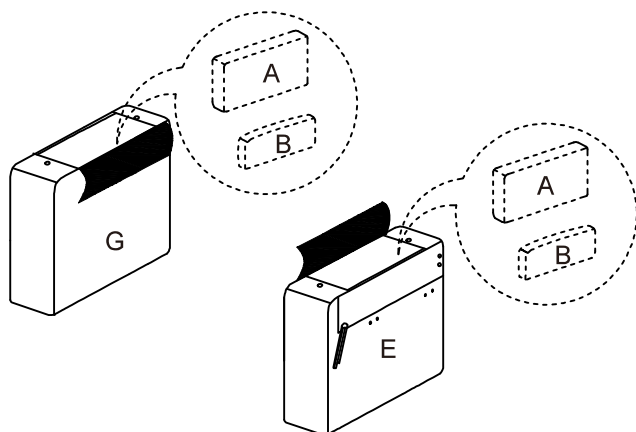

STEP 2

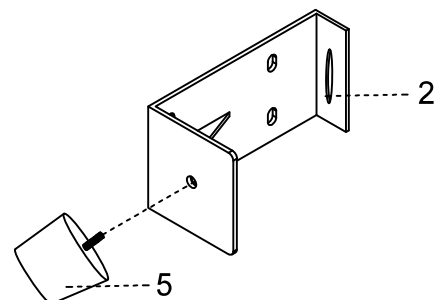

STEP 3

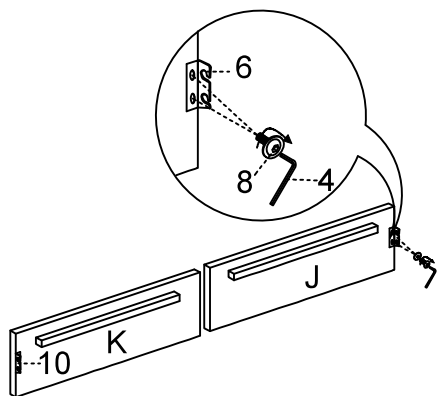

STEP 4

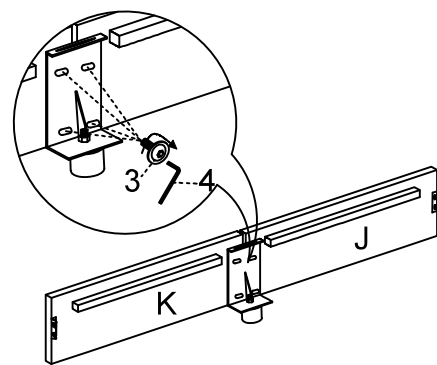

STEP 5

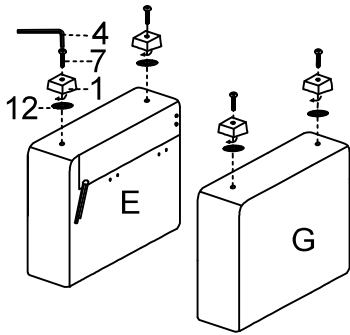

STEP 6

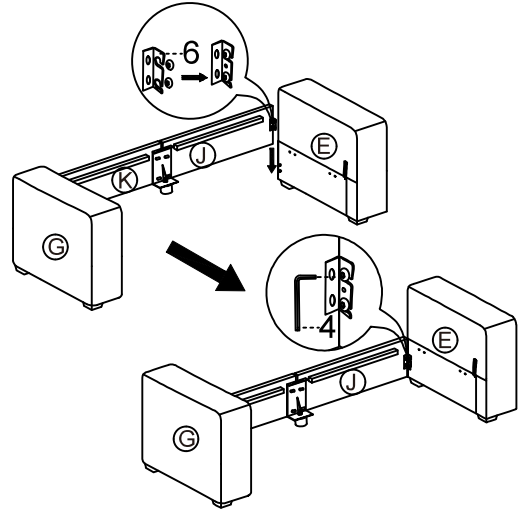

STEP 7

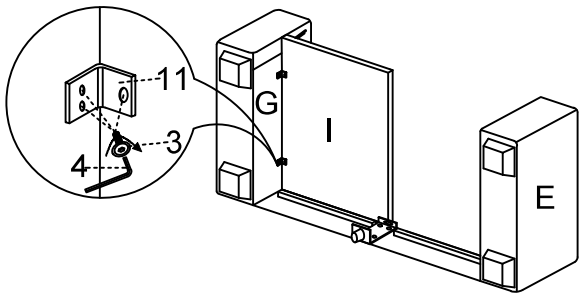

STEP 8

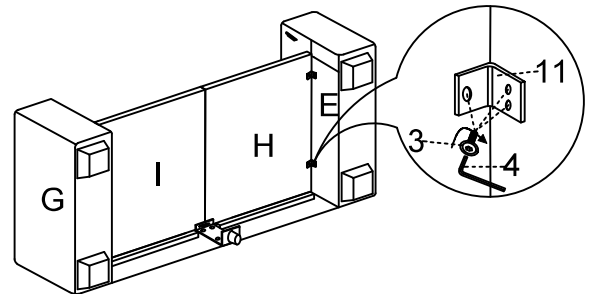

STEP 9

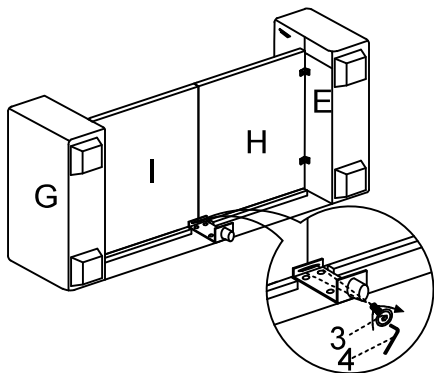

STEP 10

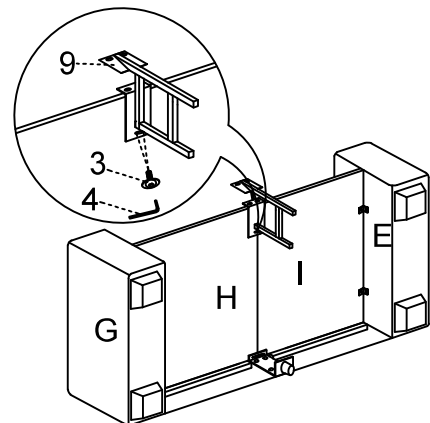

STEP 11

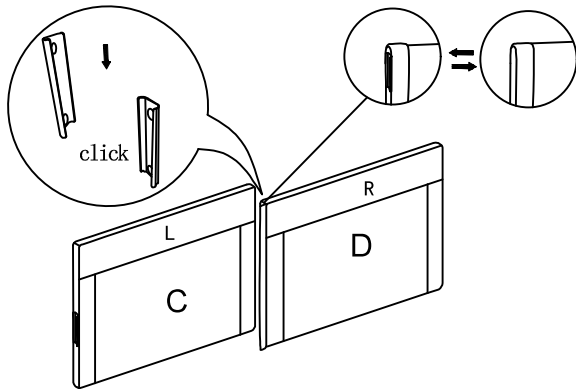

STEP 12

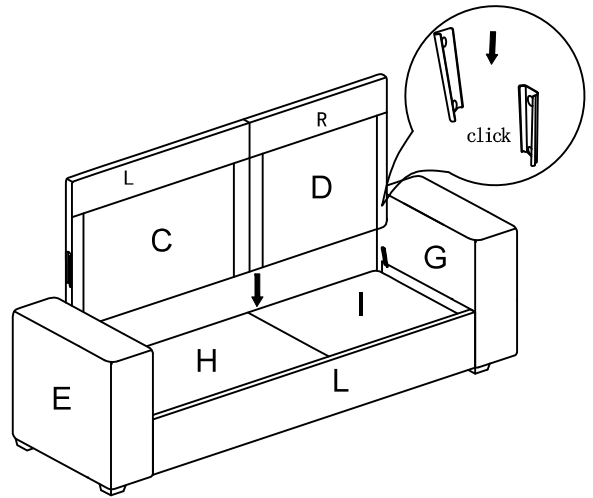

STEP 13

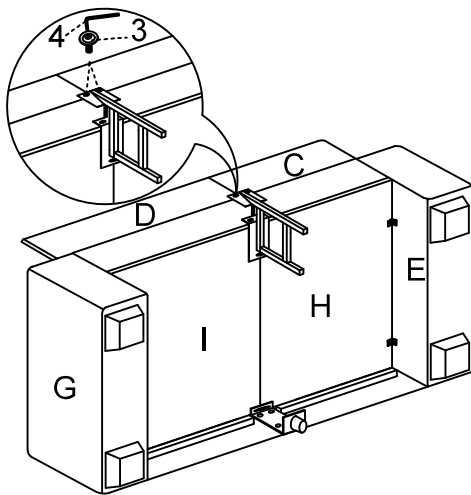

STEP 14

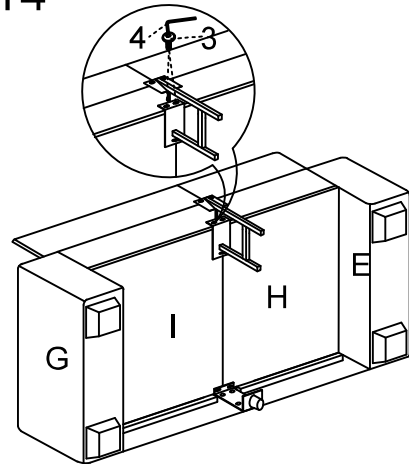

STEP 15

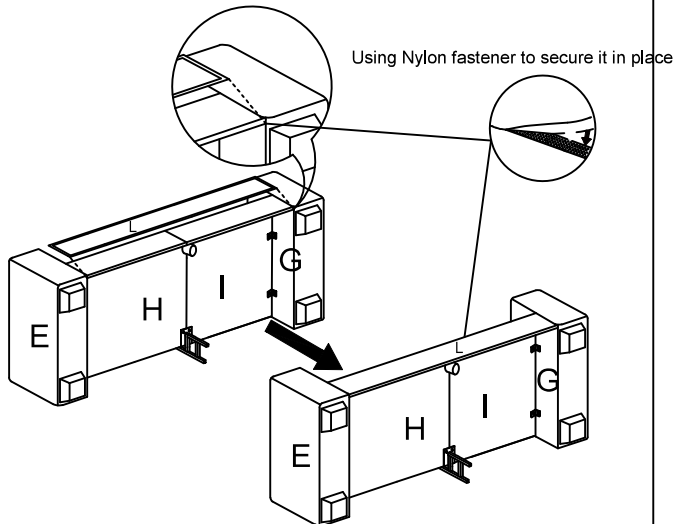

STEP 16

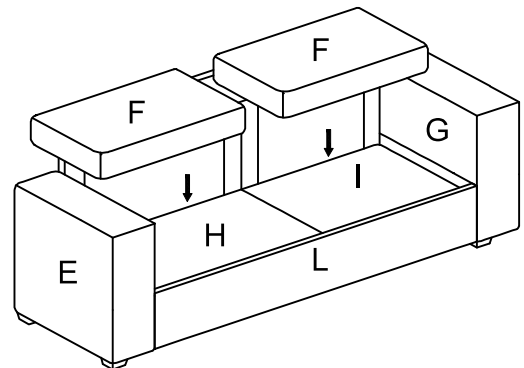

STEP 17

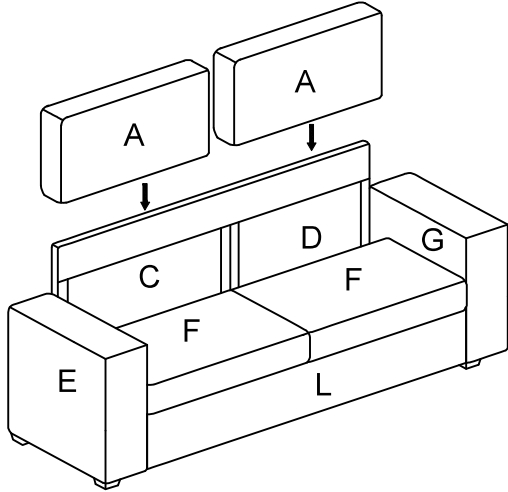

STEP 18

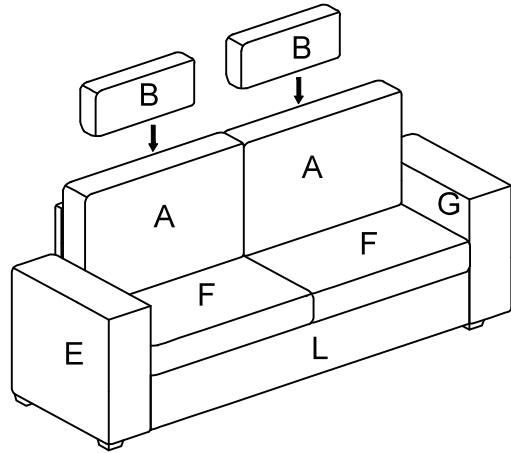

STEP 19

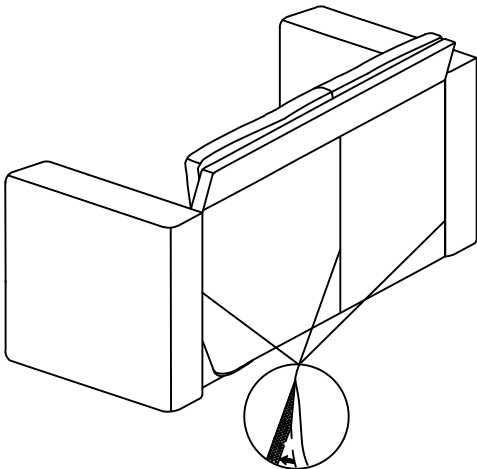

Using Nylon fastener to secure it in place

STEP 20

