

**METAL QUEEN SIZE BED**

**ASSEMBLY INSTRUCTION**



# Assembly Instruction







## ASSEMBLY TIPS:

1. Remove hardware from box and sort by size.
2. Please check to see that all hardware and parts are present prior to start of assembly.
3. Please follow attached instruction in the same sequence as numbered to assure fast & easy assembly.

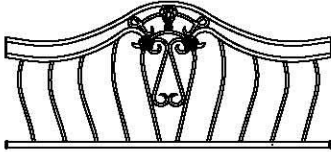







### ▲Warning!

1. Don't attempt to repair or modify parts that are broken or defective. Please contact the store immediately.
2. This product is for home use only and not intended for commercial establishment.

## PARTS LIST:

A. FRAME		2 PCS
B. POST FOR HEADBOARD (LEFT)		1 PC
C. POST FOR HEADBOARD (RIGHT)		1 PC
D. POST FOR FOOTBOARD (LEFT)		1 PC
E. POST FOR FOOTBOARD (RIGHT)		1 PC
F. BALL		8 PCS
G. FOOT PAD		4 PCS

## Z HARDWARE LIST:

NO.	DESCRIPTION	FIGURE	QTY	NO.	DESCRIPTION	FIGURE	QTY
1	1/4"x2-1/4" LARGE BOLT		16 PCS	5	ø30Xø6.5X3.5T FLAT WASHER		8 PCS
2	1/4"x3/4" SHORT BOLT		8 PCS	6	5/16" LOCK WASHER		4 PCS
3	ø10.5Xø6.5X1.5 SPRING WASHER		8 PCS	7	4.0mm ALLEN KEY		1 PC
4	ø16Xø6.5X1.0T FLAT WASHER		12 PCS	8	10.0mm WRENCH		1 PC

**STEP 1:** Connect the parts frame(A) & post for headboard (left&right) (B&C), and screw with large Bolts (1). The put the decorating ball (F) into the top of post for headboard left(B) and post for headboard right (C),

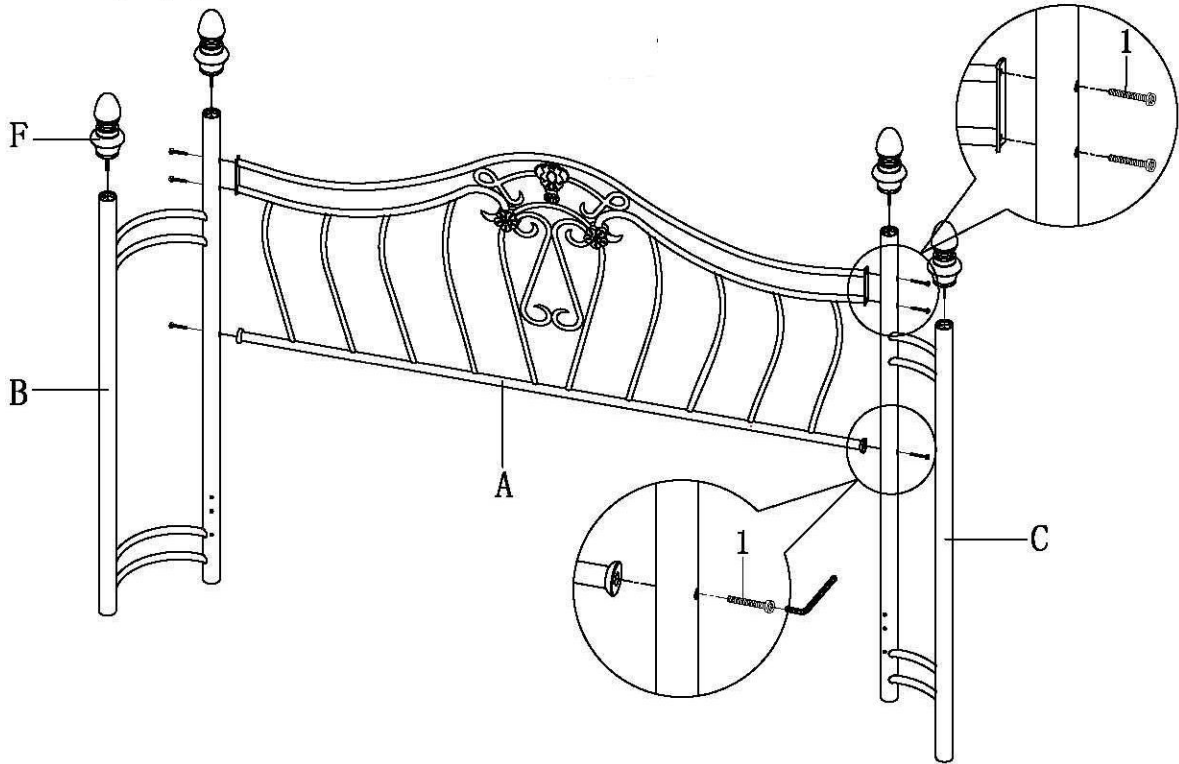

**STEP 2:** Put the foot pad (G) into post for footboard (left&right) (D&E), screw with short Bolts (2) flat washer (4) put the decorating ball (F) onto post for footboard(left& right) (D&E), then connect the parts post for footboard(left)(D), post for footboard(right) (E) to parts frame(A)

