

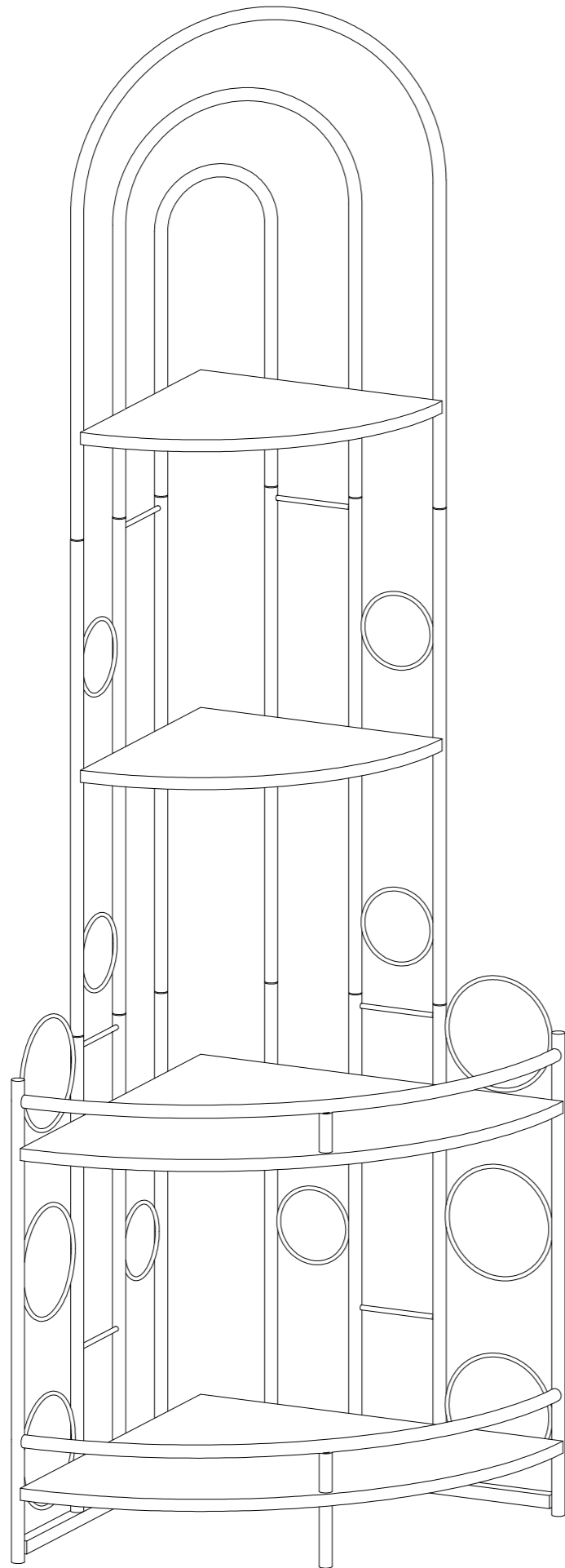







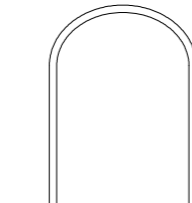
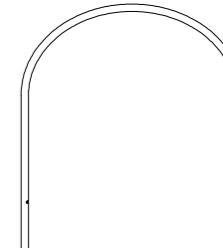
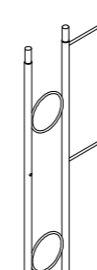
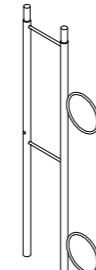
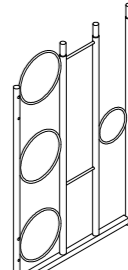

ASSEMBLY INSTRUCTIONS

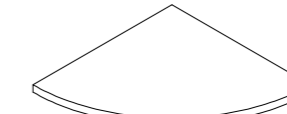
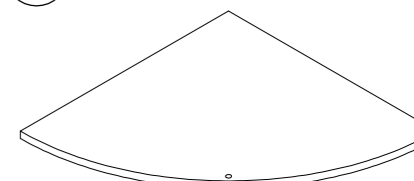

PARTS LIST

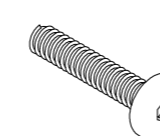
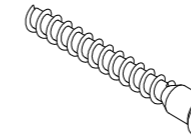
1 x1 	2 x1 	3 x1 
4 x1 	5 x1 	6 x1 
7 x1 	8 x2 	9 x2 
10 x1 	11 x2 	12 x2 

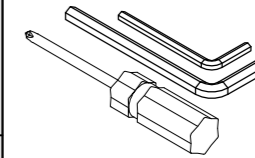
HARDWARE LIST

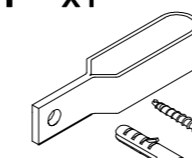
A x5 	B x16 	C x4 	D x1 	E x1 
1/4 X 1	5.0 X 40	M4 X 6		
F x1 				
4.0 X 35				

ASSEMBLY INSTRUCTIONS

When the process of product assembly, please do not lock the screws at one time, but wait until all the screws are assembled to the position, and then straighten and flatten the product, and then tighten the screws of the same height in turn, so as to avoid unsmooth assembly and product tilt.

STEP 1

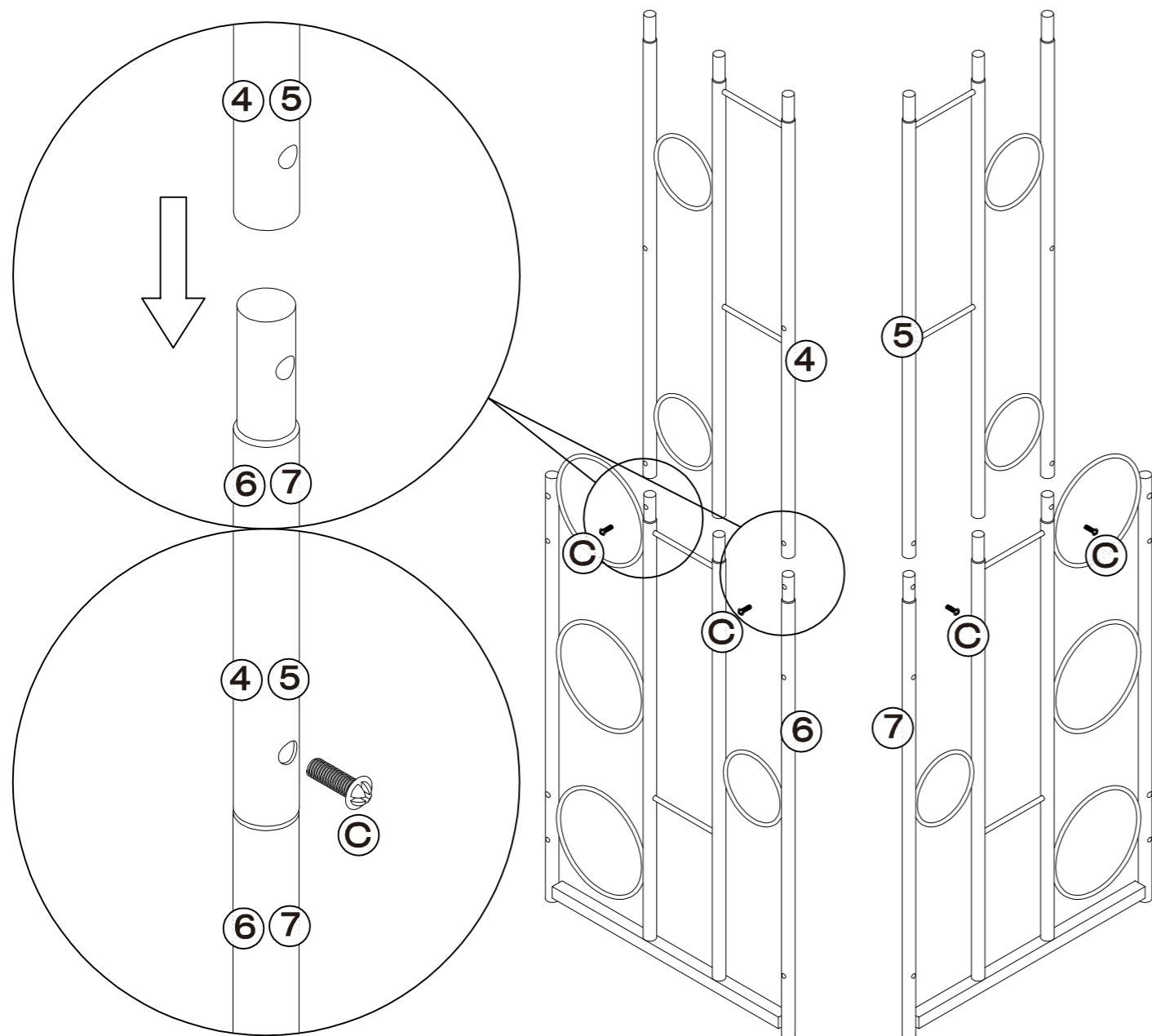

C x 4

STEP 2

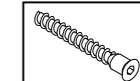
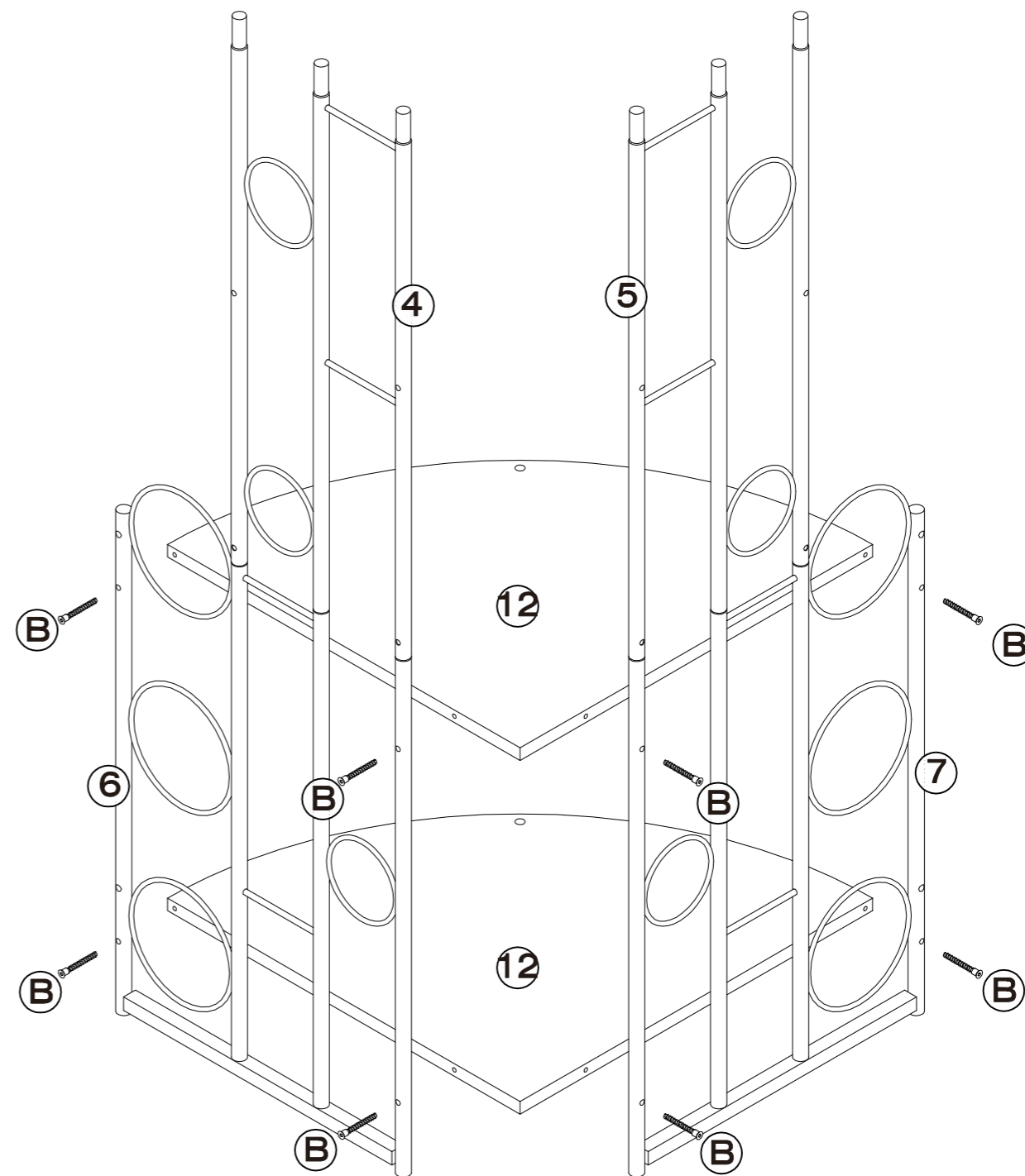

B x 8

ASSEMBLY INSTRUCTIONS

STEP 3

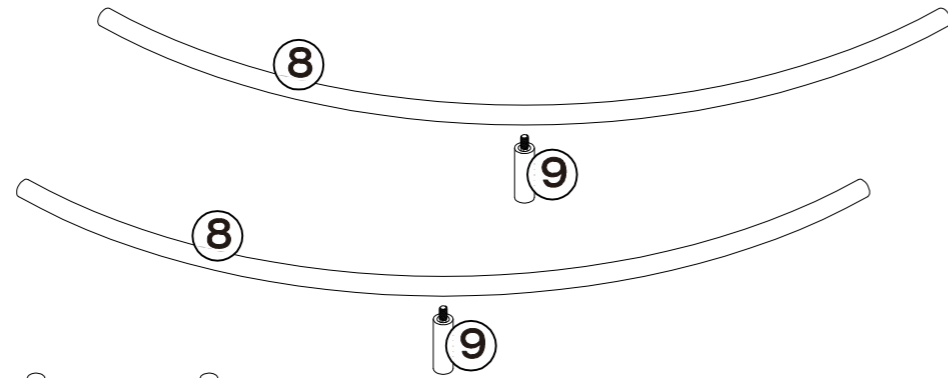

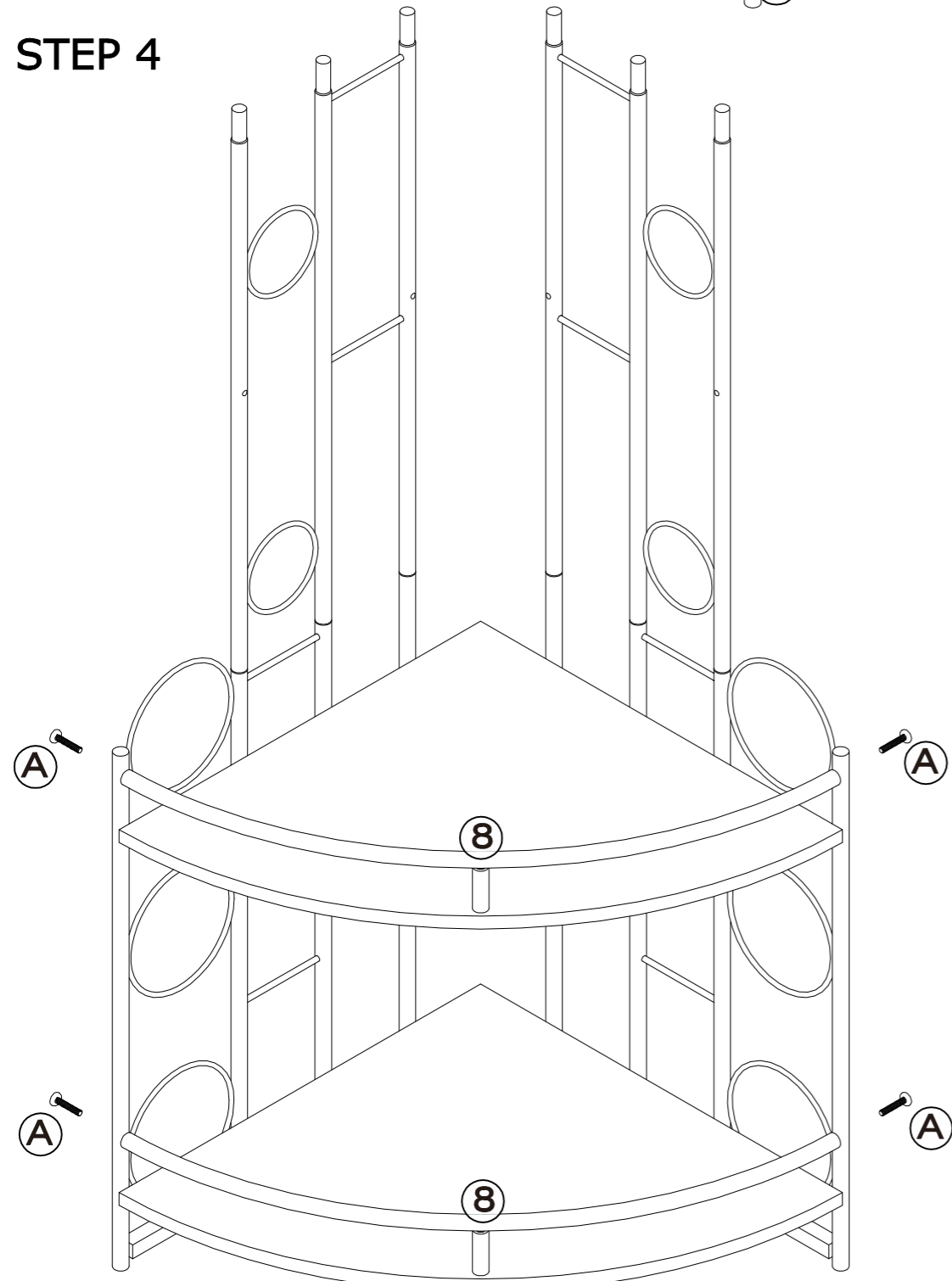

STEP 4

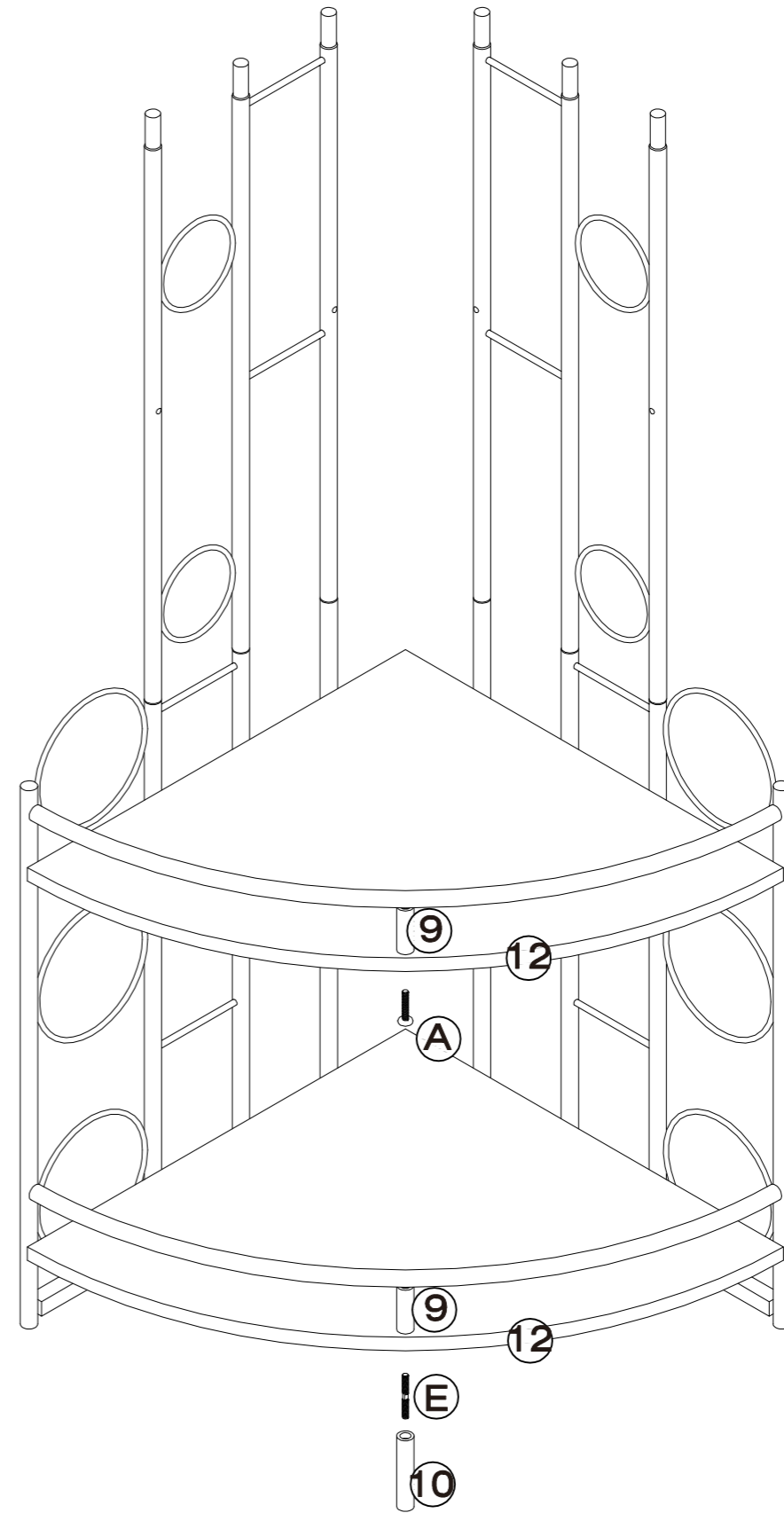

 A x 4

STEP 5



	A x 1
	E x 1

ASSEMBLY INSTRUCTIONS

STEP 6

Please note: the hole must be face back, If you find the hole is not in the right position, please turn the Part1 & Part3 over 180 degrees.

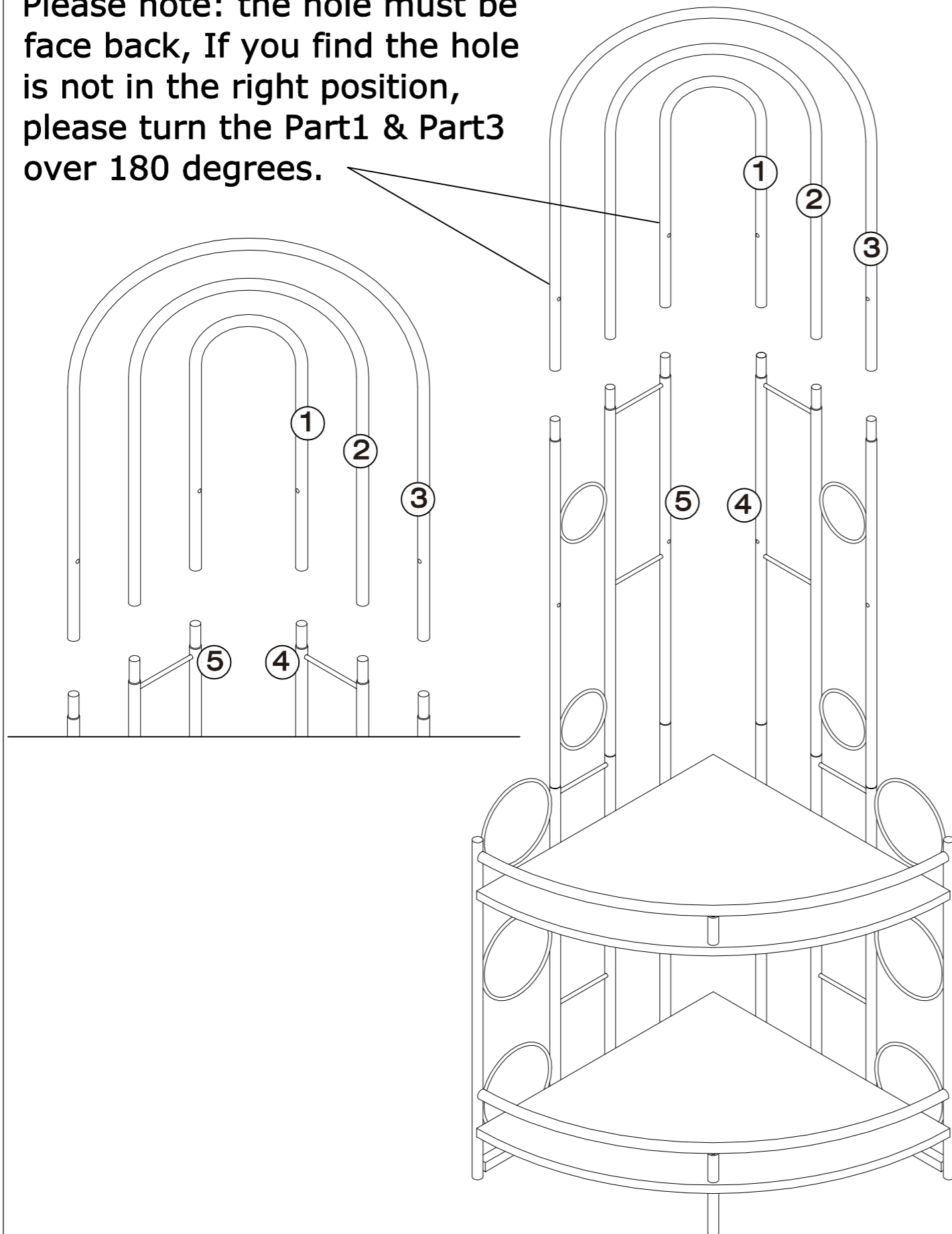

STEP 7

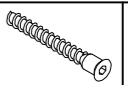
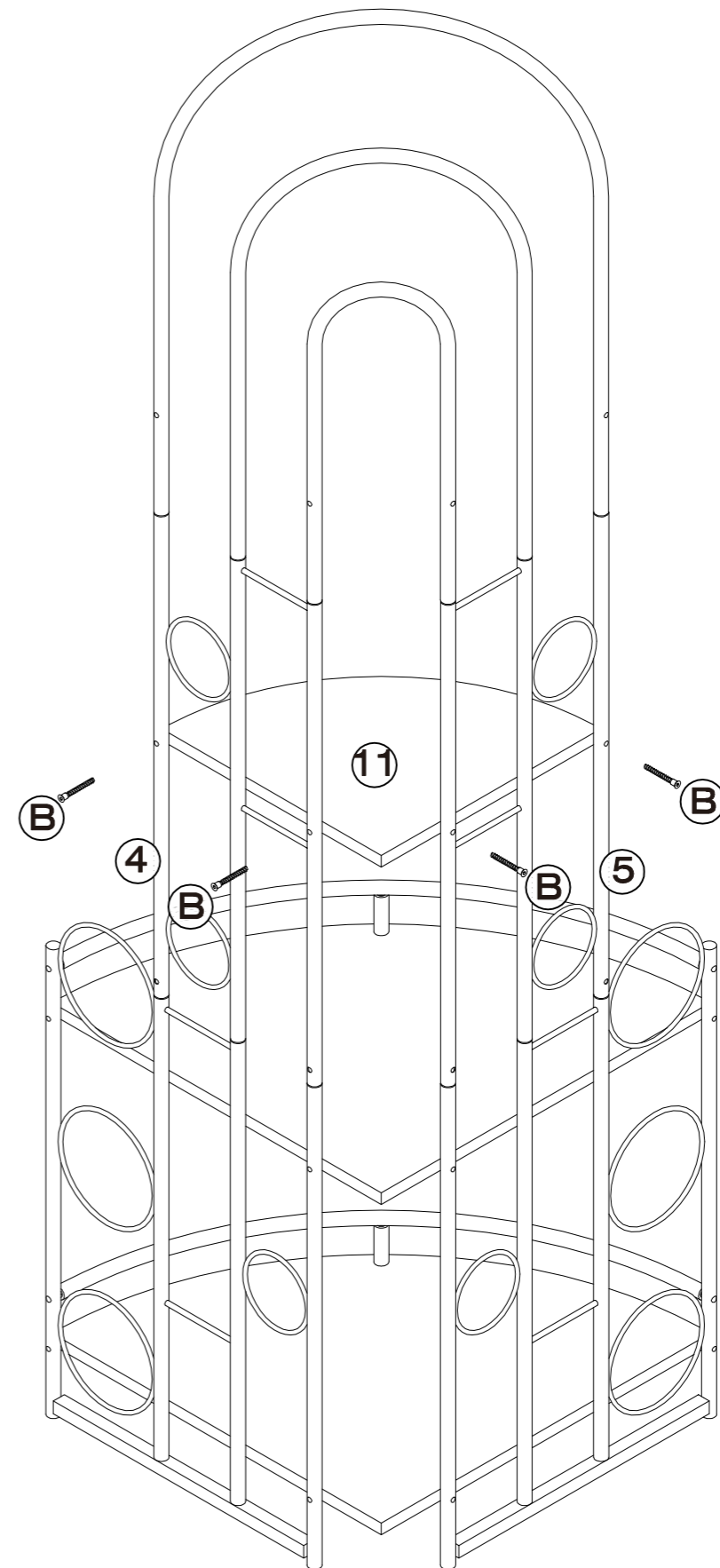

B x 4

ASSEMBLY INSTRUCTIONS

STEP 8

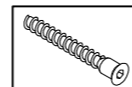
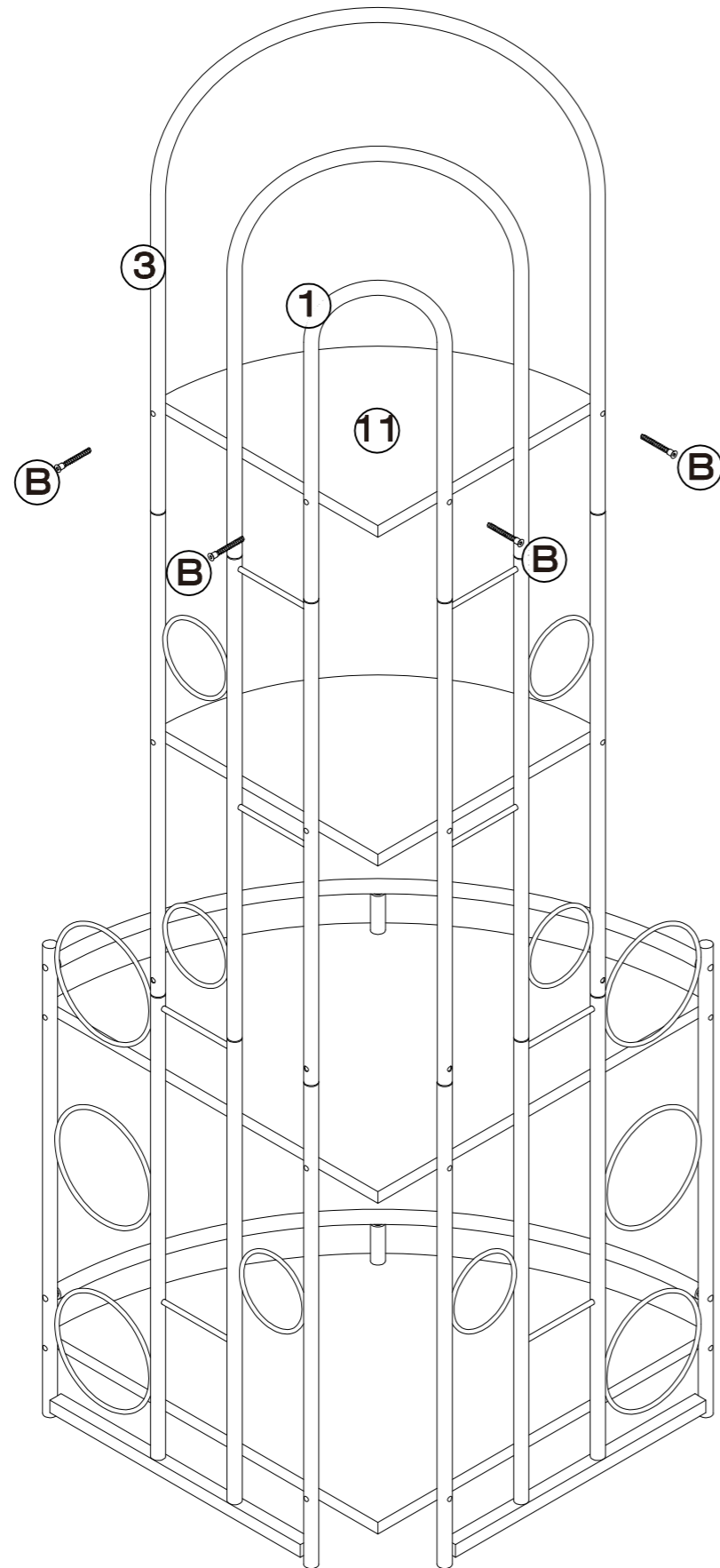

B x 4

STEP 9

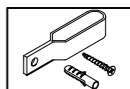
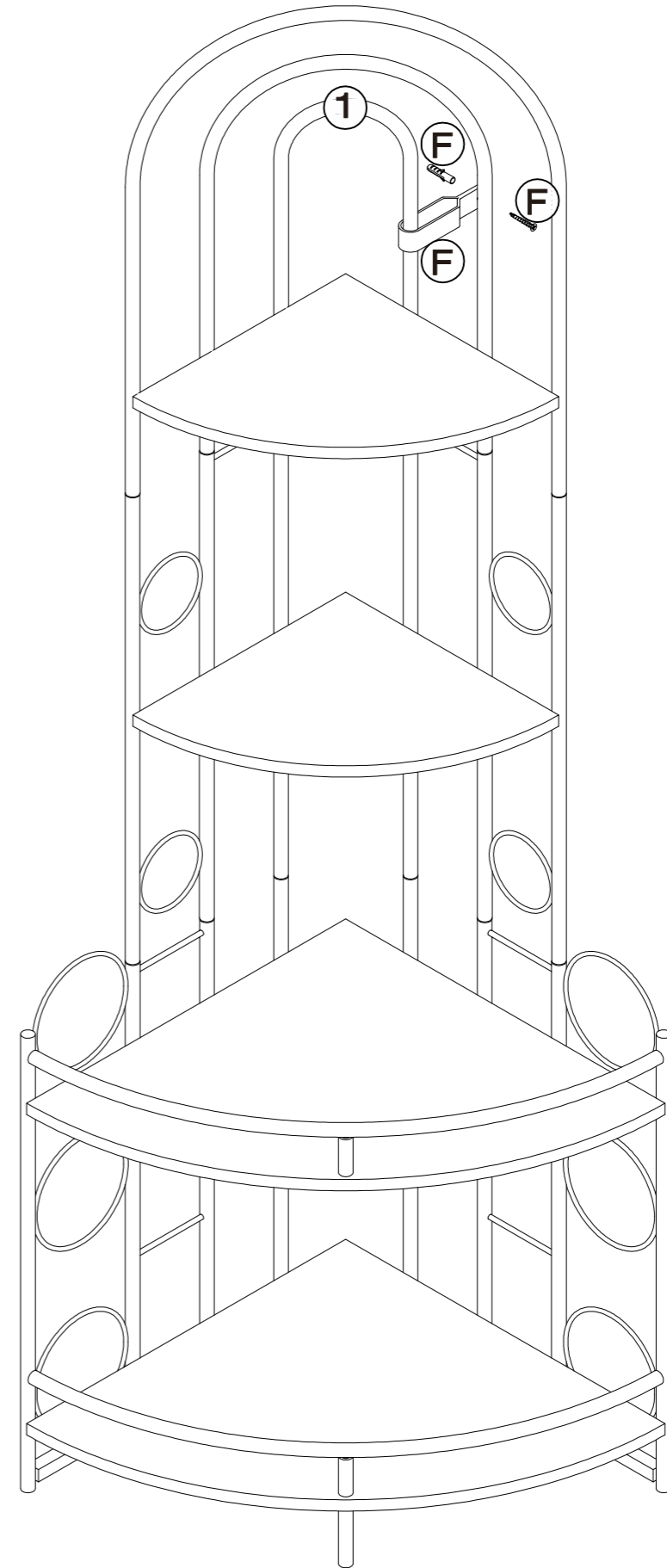

F x 1

Check and tighten all screws