

# ASSEMBLY INSRTRUCTION

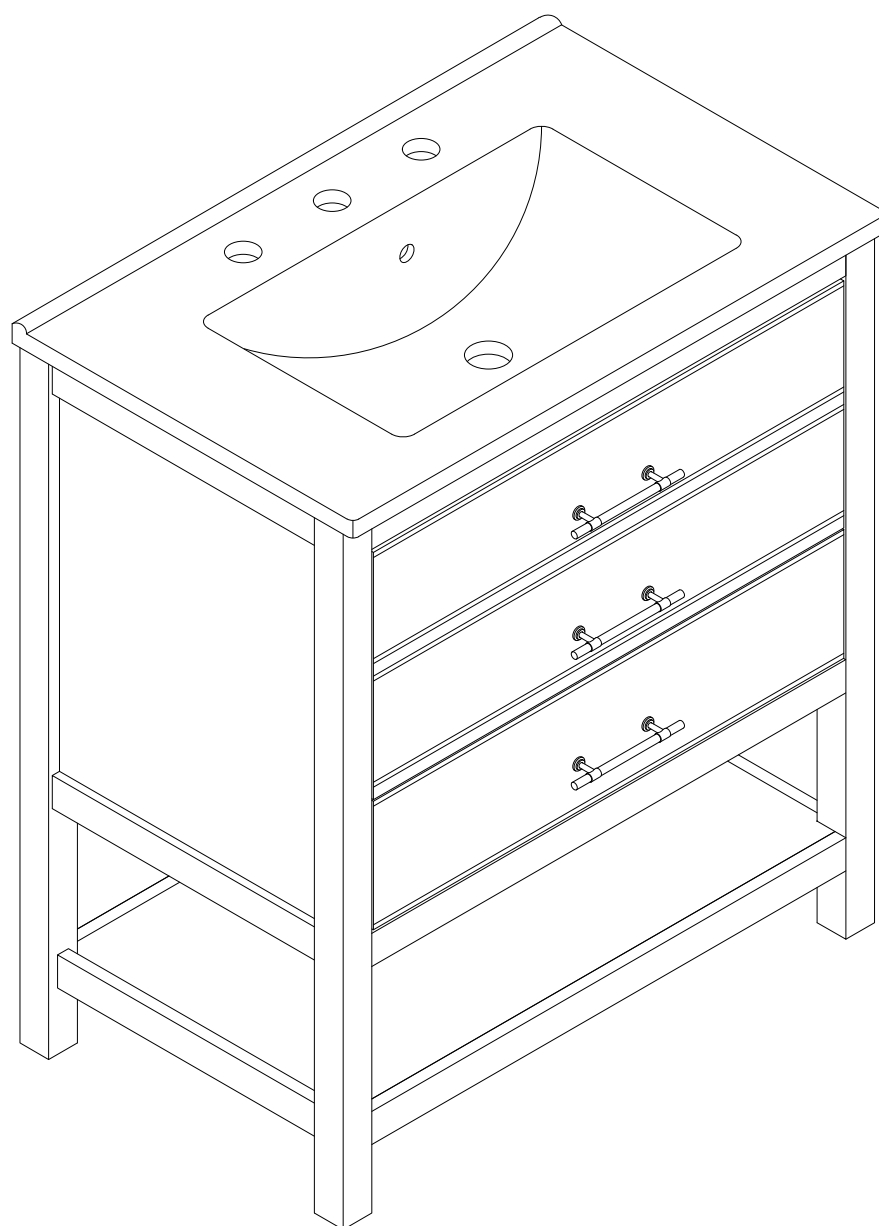

# Before Installation

**Important – Please read these instructions fully before starting assembly**

Thank you for purchasing this quality product. Be sure to check all packing materials carefully for small parts, which may have come loose inside the carton during shipment. Identify and count all items according to the PARTS LIST and/or HARDWARE LIST shown below. Check you have all the components and tools listed on the following pages.

- We recommend that you assemble this product with the assistance of another person; this will make the assembly easier, and will help eliminate damage to the product or injury to persons during assembly.
- Please do not over tighten screws or bolts until the assembly is completed.
- Keep children and animal away from the work area, small parts could choke if swallowed.
- Please put all parts on a non-abrasive floor before assembly, and follow the assembly steps to assemble your newly purchased product correctly and efficiently.

## Cam Lock Assembly Instructions

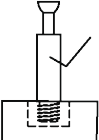
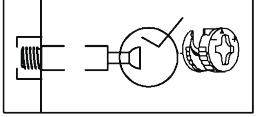
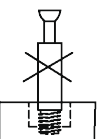
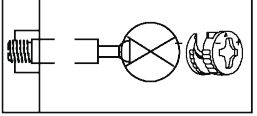
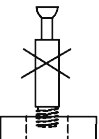
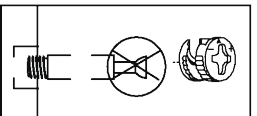
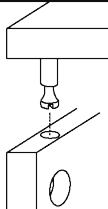
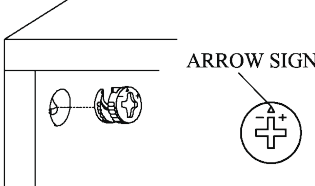
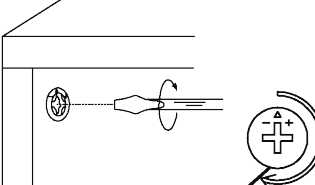
		Diagram A Insert Cam Bolt into hole as shown in diagram A.
		Diagram B Make sure not to insert the Cam Bolt: Too deep as shown in figure B as this will cause the Cam Lock to be misaligned and unable to interlock properly.
		Diagram C Also avoid inserting the Cam Bolt too close to the surface of the hole as shown in figure C, as this will cause the Cam Lock to be too loose, and not interlock properly.
		Connect the panels together.
	ARROW SIGN	Insert the Cam Lock so the side opening fits over the head of the Cam Bolt.
		To tighten the Cam Lock, turn it clockwise on half a turn with a flat screwdriver. <i>*Do not use an automatic screwdriver as it may bend or break if too much power is imposed.</i>

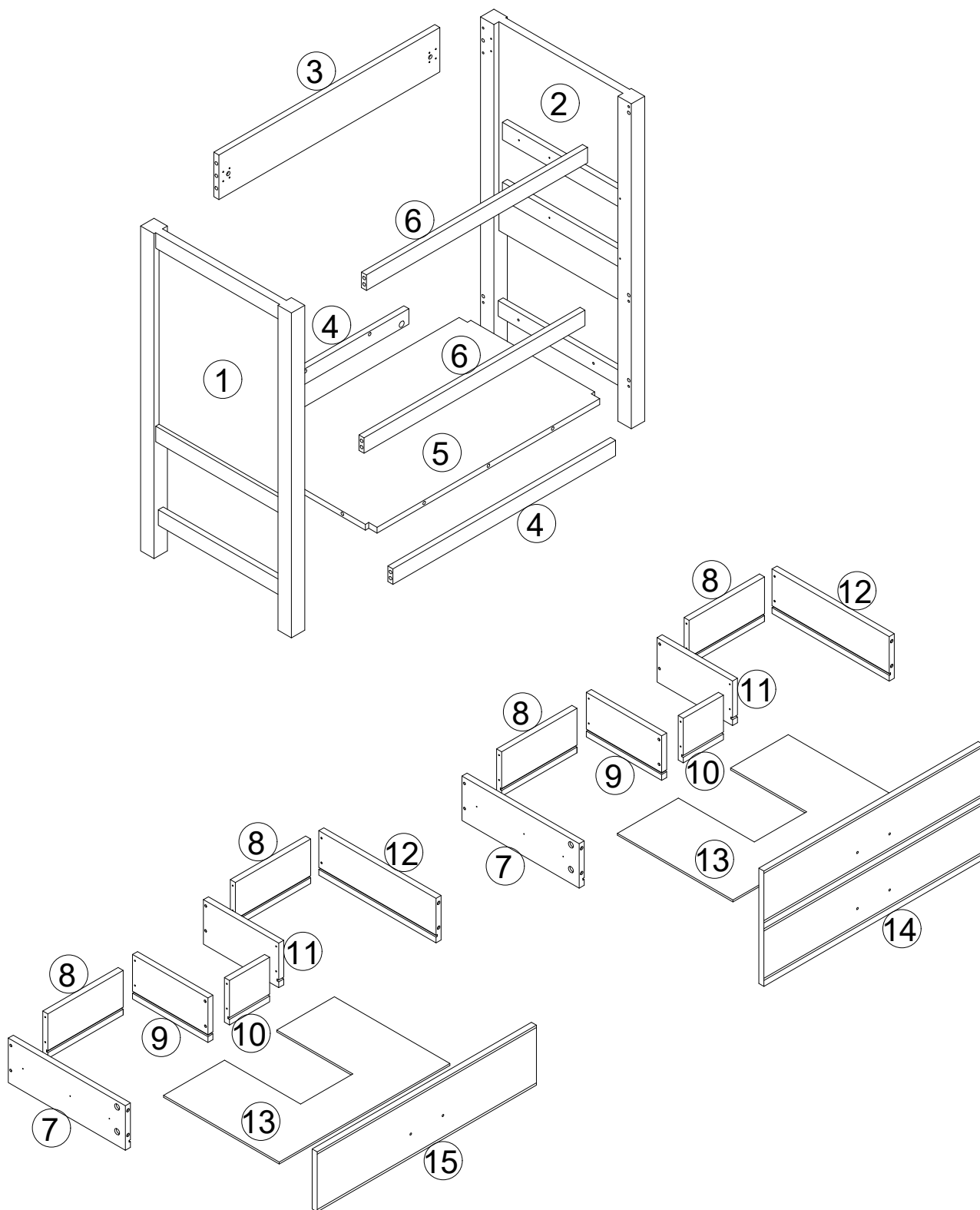

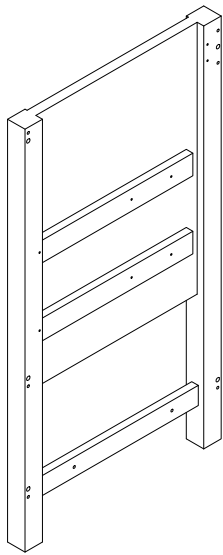

① x 1

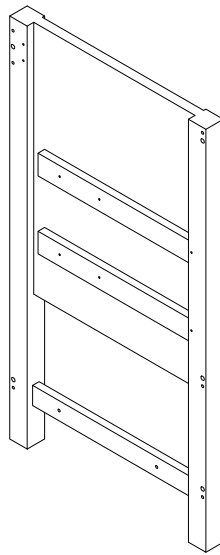

② x 1

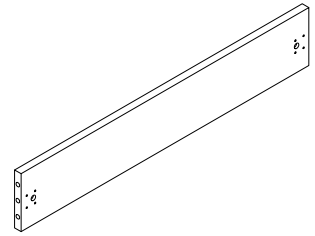

③ x 1

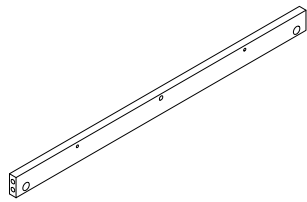

④ x 2

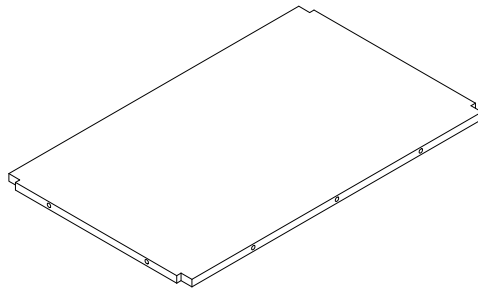

⑤ x 1

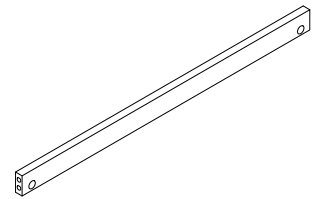

⑥ x 2

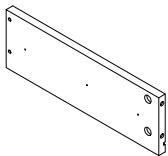

⑦ x 2

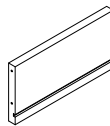



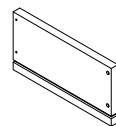



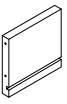
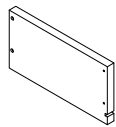
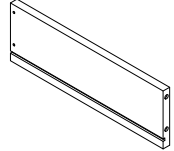
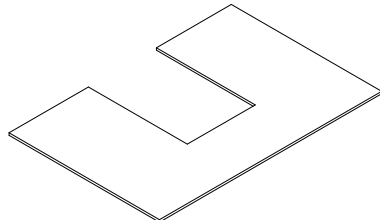
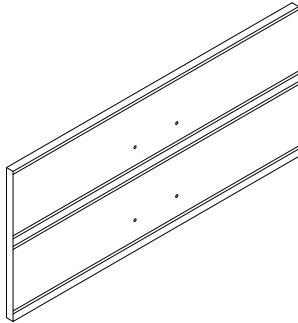
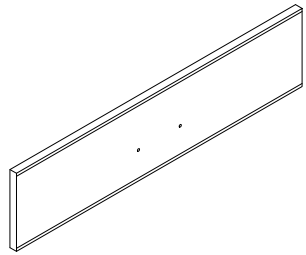

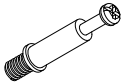

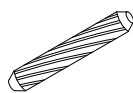
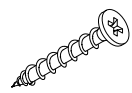
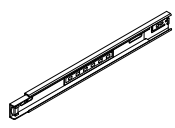
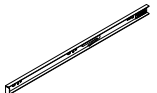
⑧ x 4

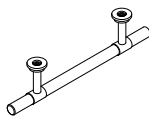

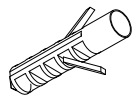
⑨ x 2

		
⑩ x 2	⑪ x 2	⑫ x 2
		
⑬ x 2	⑭ x 1	⑮ x 1

 Φ6x35mm A x 28+2	 Φ15x12mm B x 28+2	 Φ8x30mm C x 12+1	 Φ4x35mm D x 24+2	 E x 4	 F x 4
 Φ4x22mm G x 6	 H x 3	 Φ4x14mm I x 12+1	 J x 2	 Φ8x40mm K x 2	 Φ20 L x 2
 Φ6x60mm M x 2	 Φ4x14mm N x 24+2				

**Slides Must Be Separated Before Assembly.  
After Separated, Set Aside Until Needed for Assembly.**

Las diapositivas deben separarse antes del montaje.  
Después de la separación, déjelo a un lado hasta que sea necesario.

Les glissières doivent être séparées avant l'assemblage.  
Après la séparation, mettez de côté jusqu'au moment de l'assemblage.

**Pay attention when connecting !  
The sliding module must be at the front end.**

STEP 1 : Extend Slide  
Extender la diapositiva

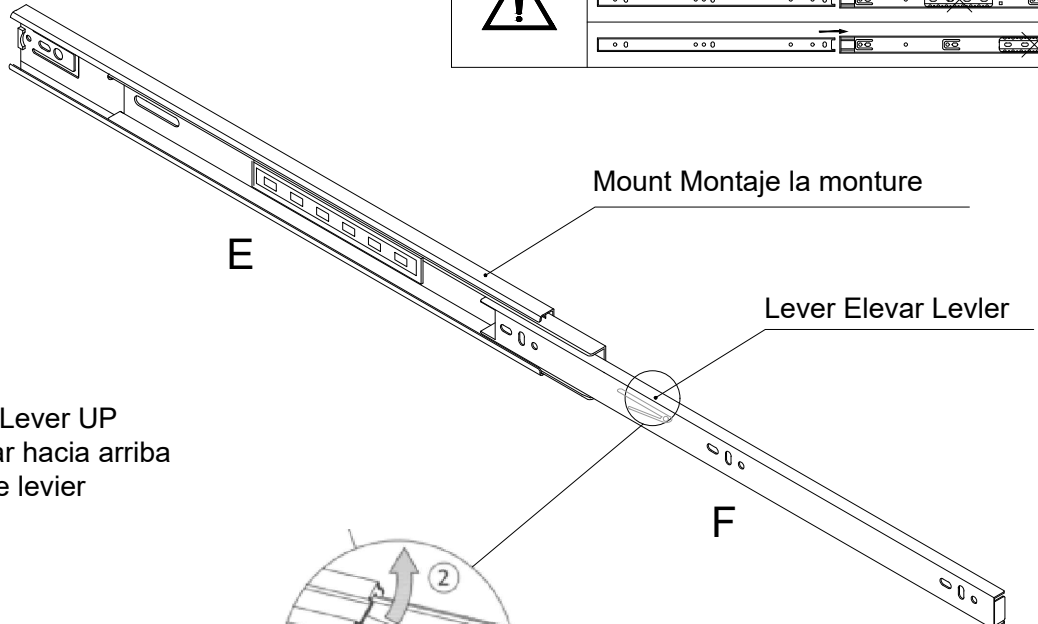
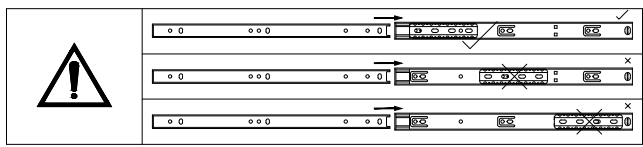

STEP 2: Push Lever UP  
Empujar hacia arriba  
Lever le levier

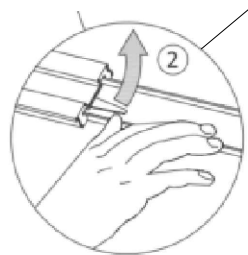

**Push lever for the left of drawer ,  
press the lever for the right of drawer.**

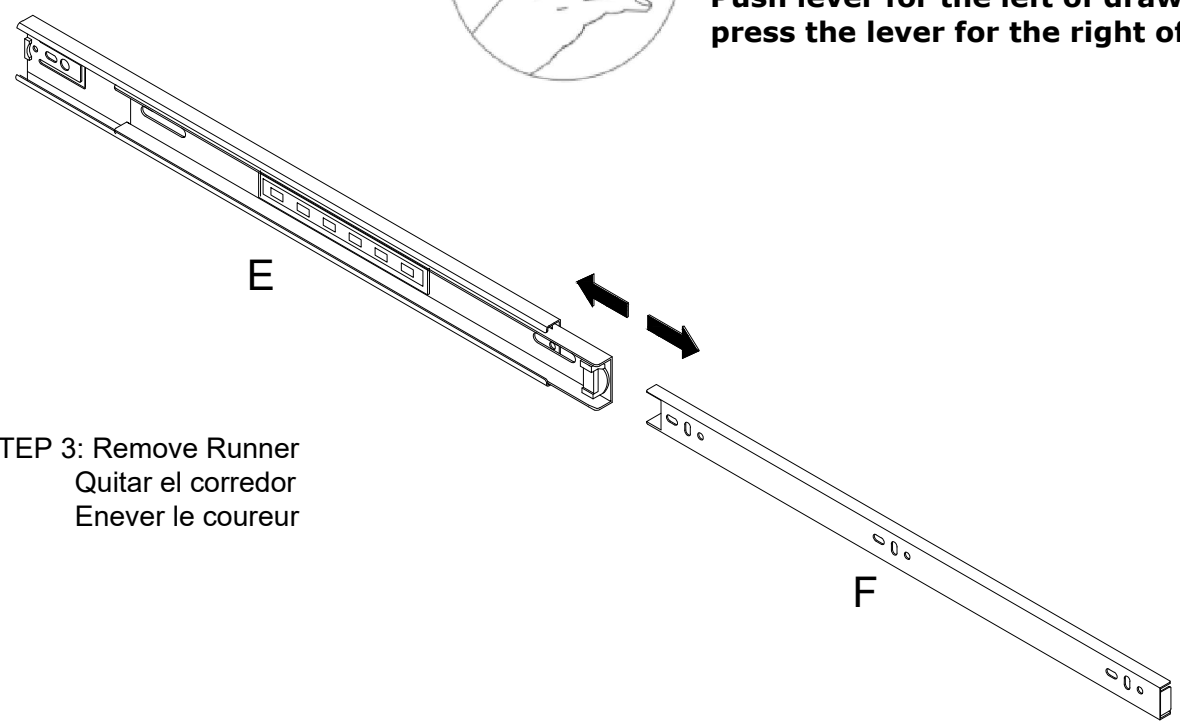

STEP 3: Remove Runner  
Quitar el corredor  
Enever le coureur

## Step 1

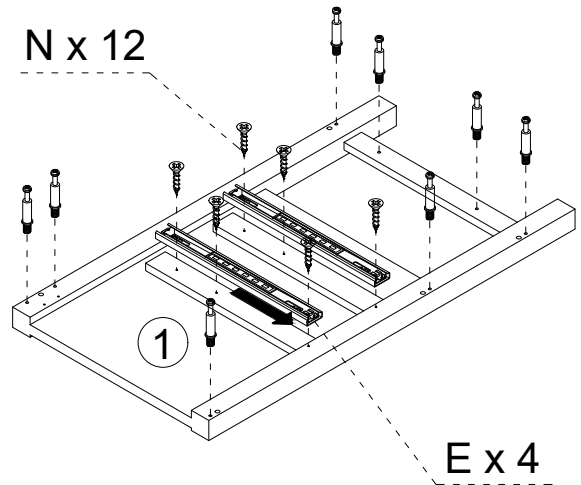
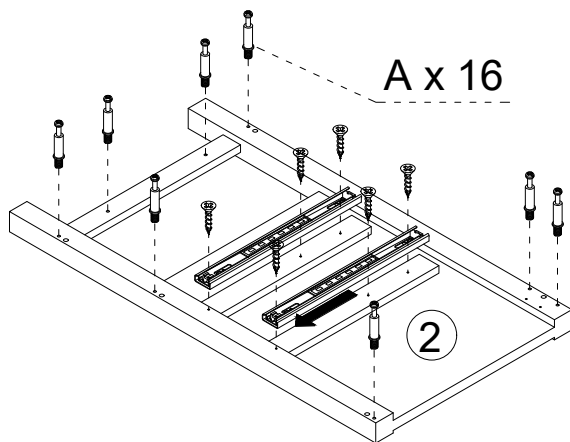

The slide rail can be pulled out in this direction

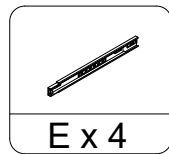
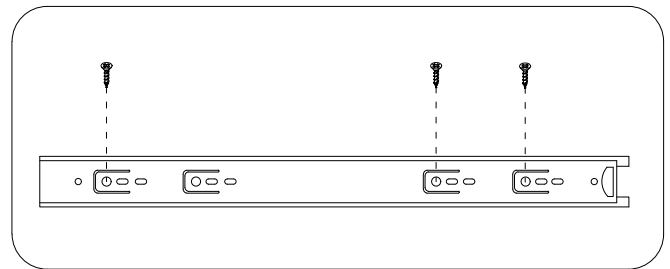

## Step 2

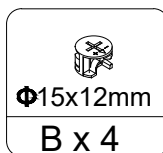
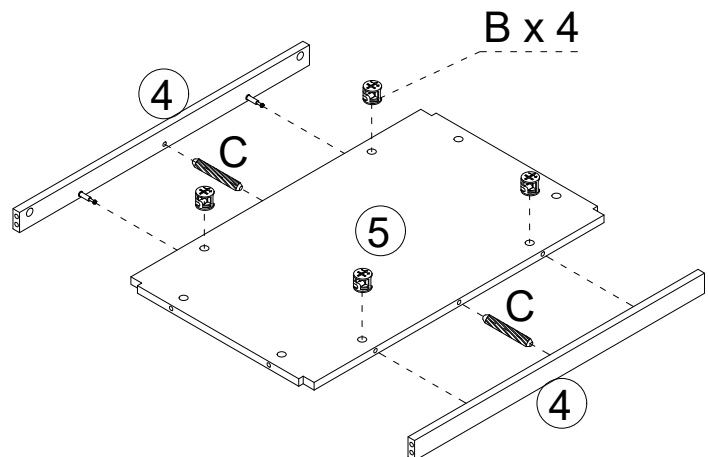
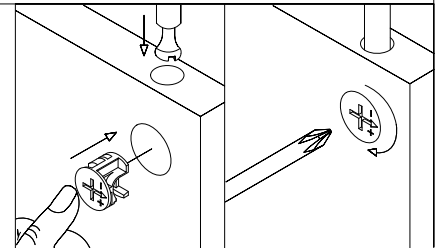
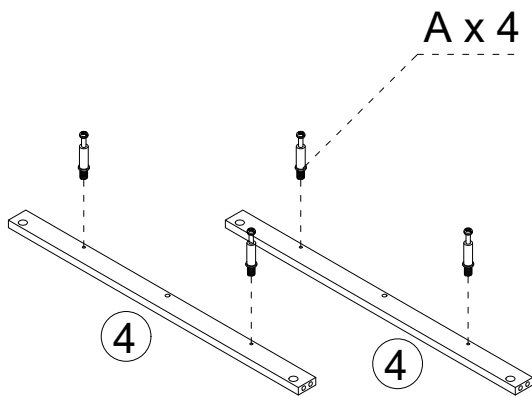

### Step 3

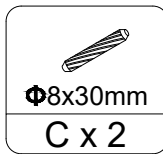
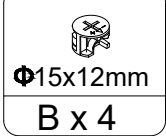
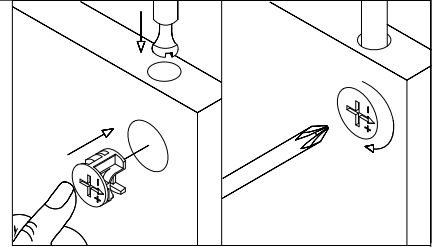
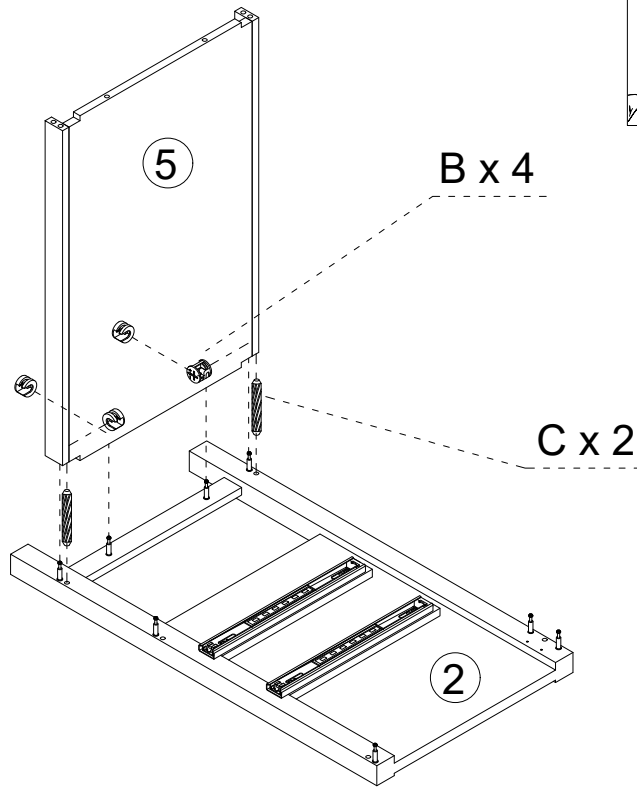

### Step 4

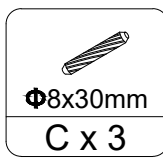
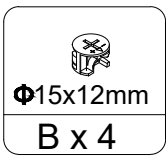
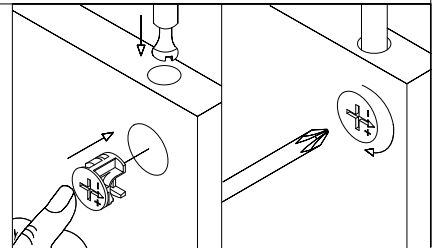
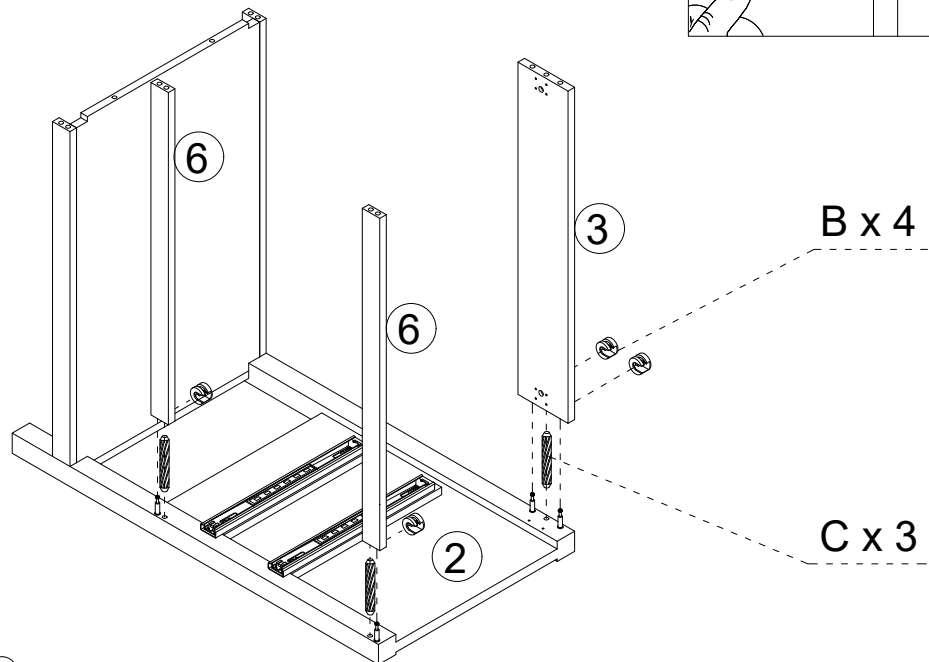

## Step 5

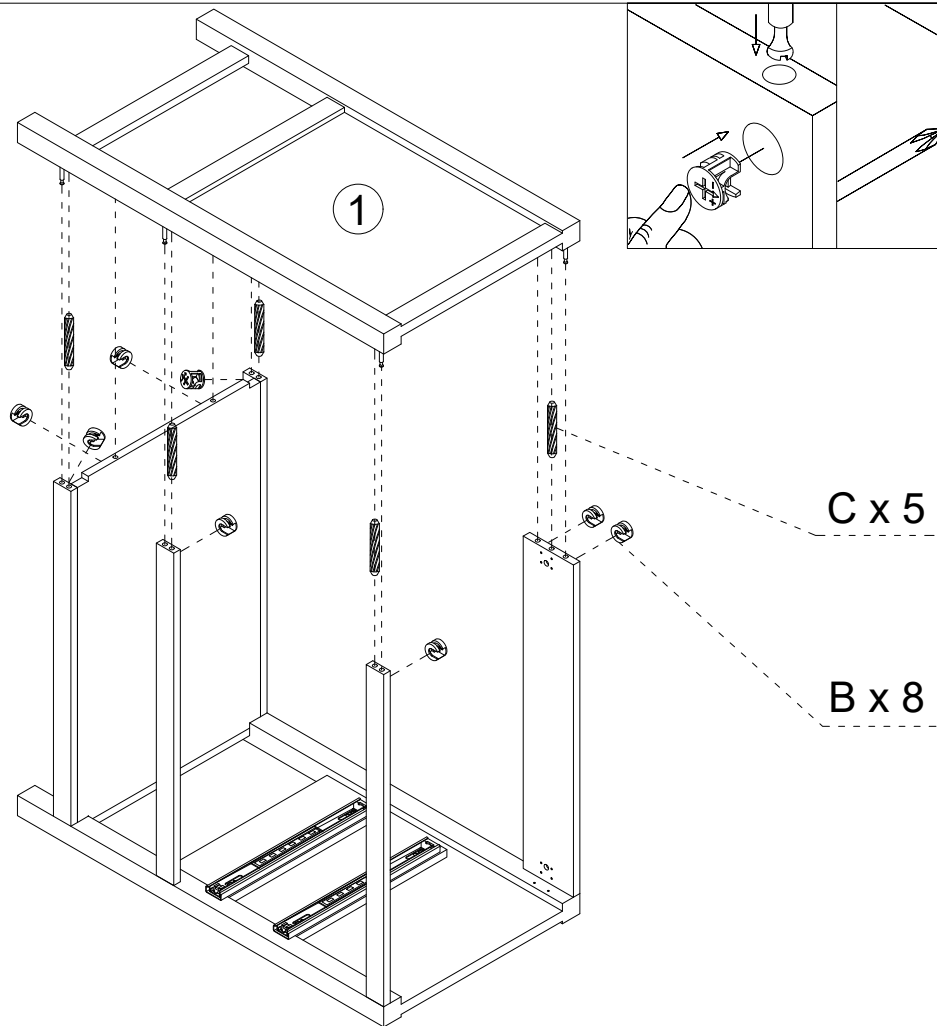

## Step 6

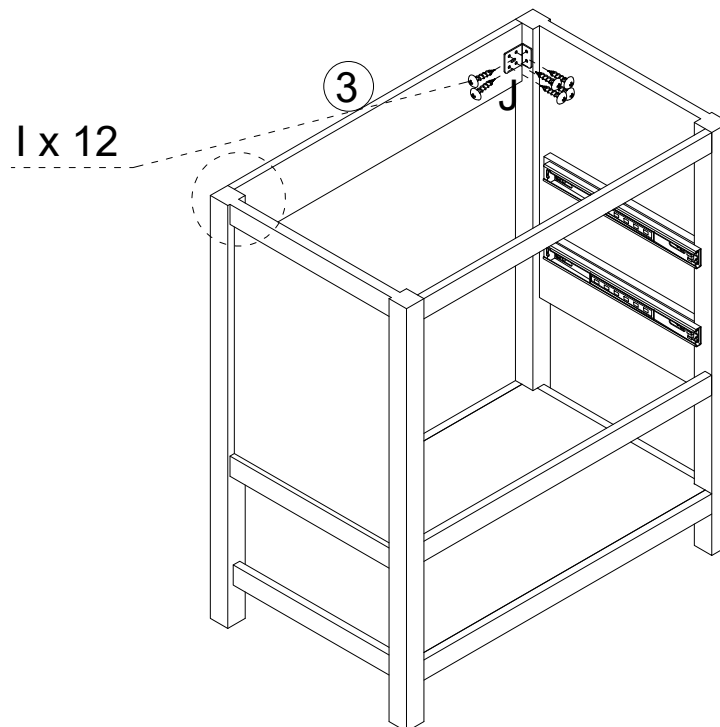

## Step 7

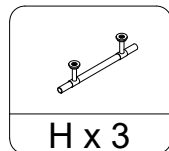
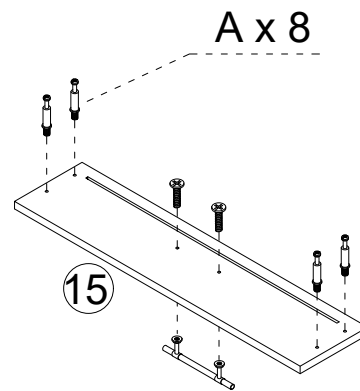
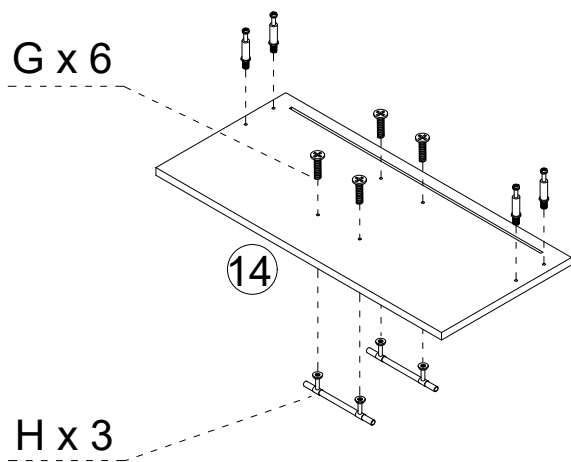

## Step 8

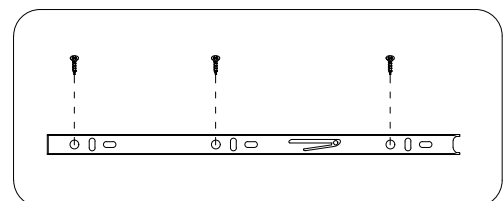
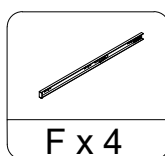
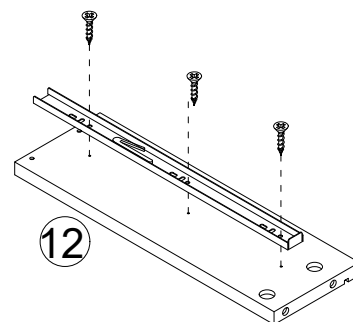
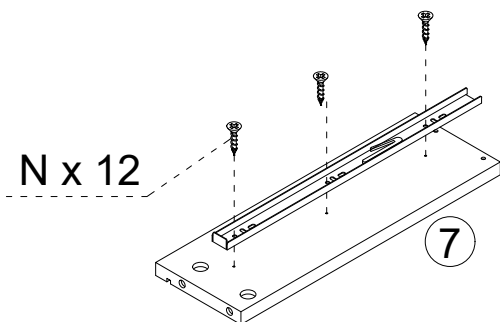
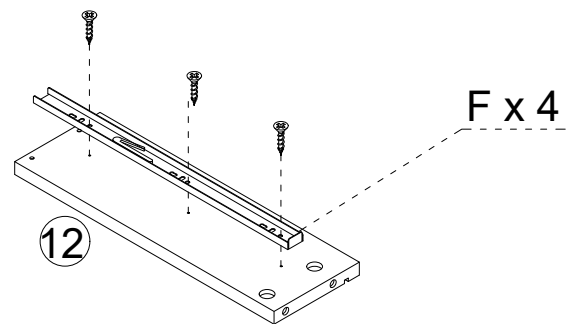
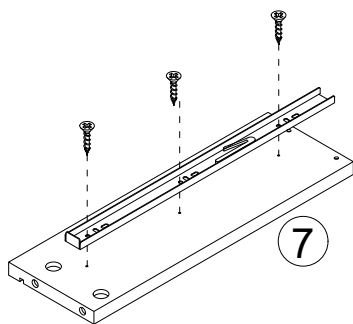

## Step 9

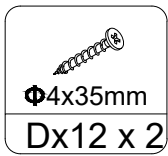
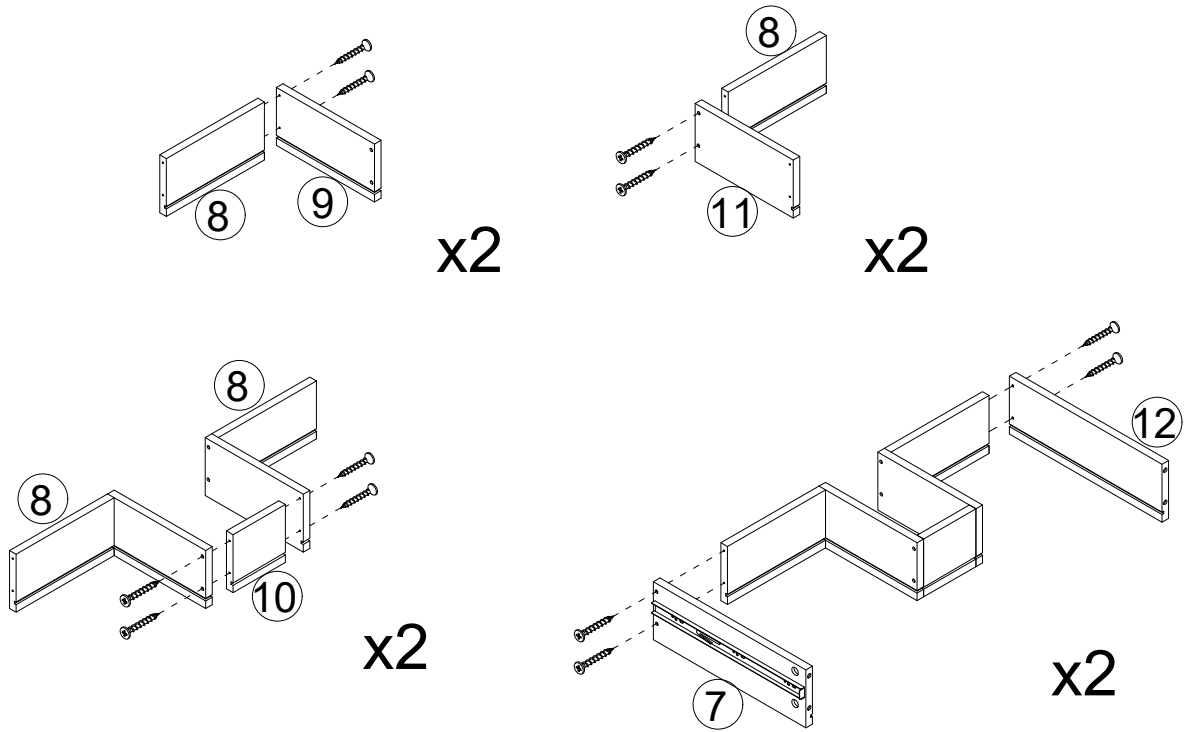

## Step 10

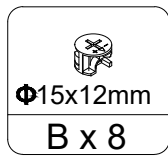
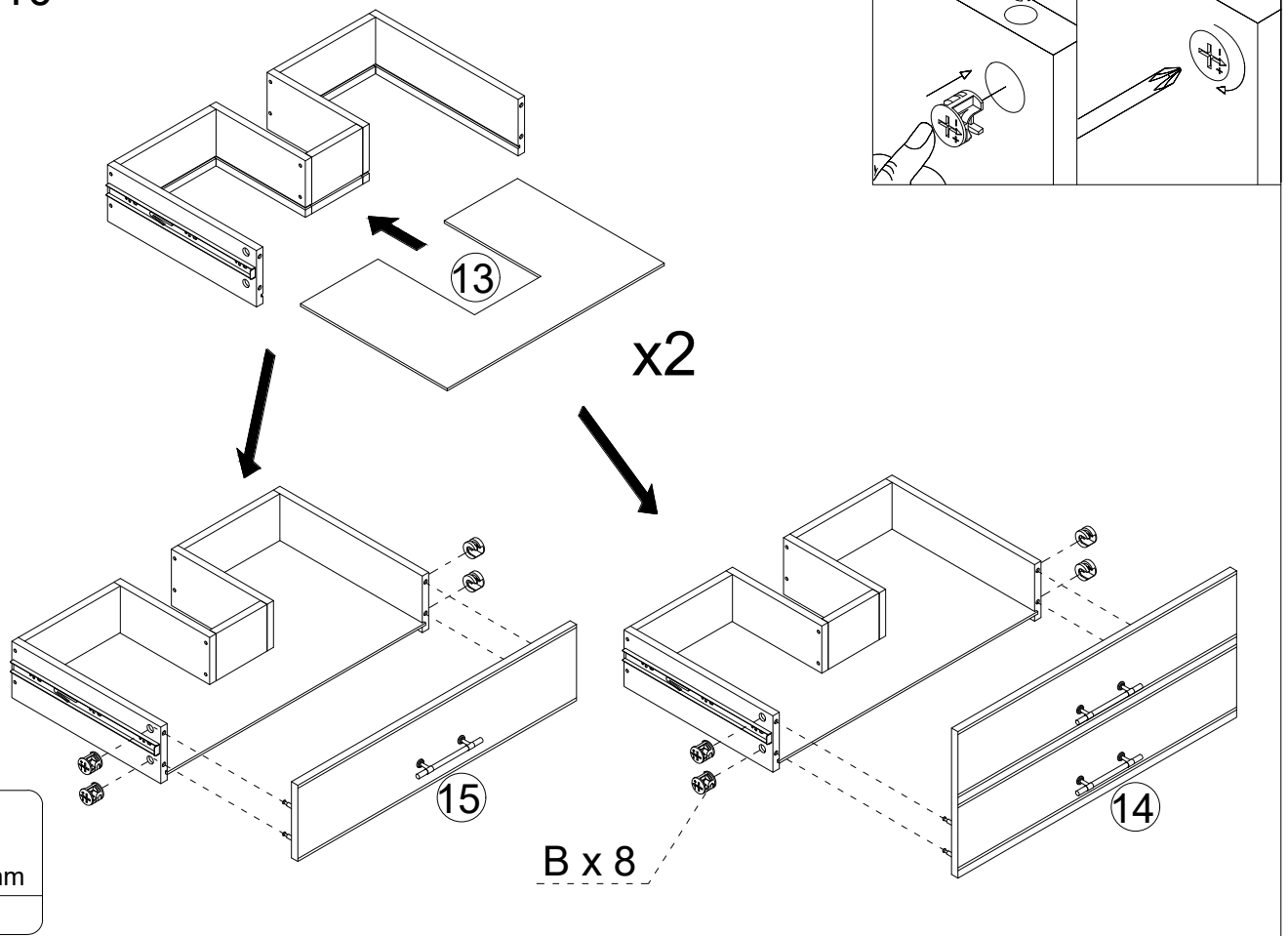

# Step 11

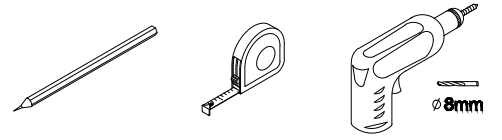

Wall

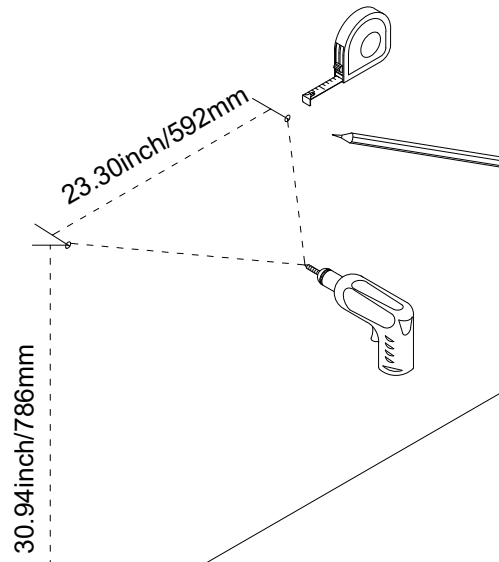

# Step 12

Wall

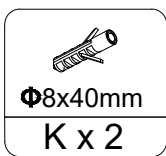
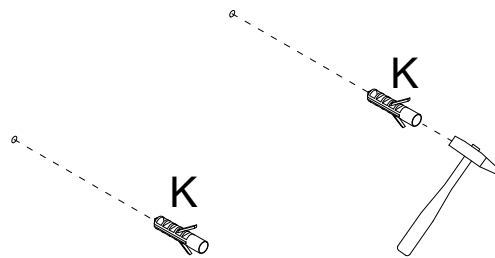

# Step 13

Wall

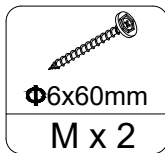
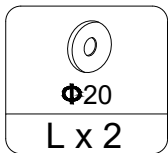
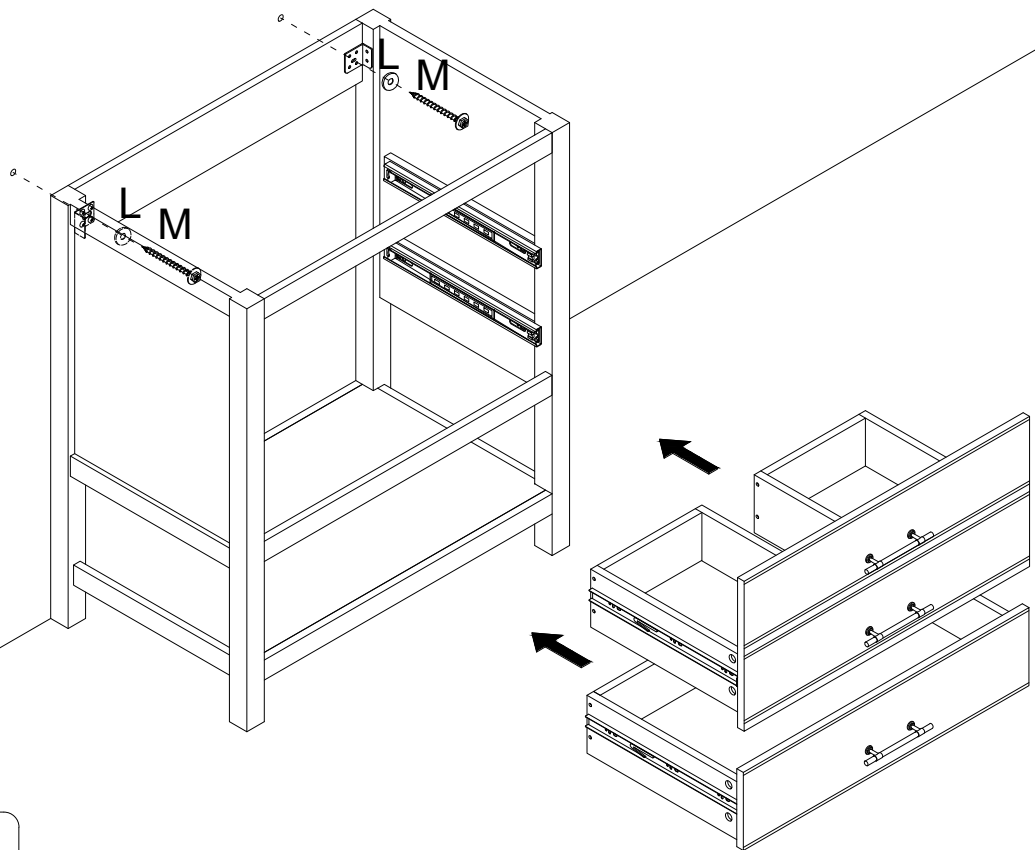

# Step 14

