







CARE AND MAINTENANCE

Always use felt pads under all articles to prevent discoloration or softening of the lacquer. Plastic and rubber bases on items can discolor wood. Wipe up spills immediately and avoid common hazards such as hot dishes, harsh solvents and abrasives. Cleaning should be done with a soft lint free cotton cloth dampened with water or furniture polish. On highly used surfaces we recommend applying a quality paste wax which should be used on a regular basis to provide additional protection from scratches and spills. How often you apply the wax depends on how much wear the furniture receives.

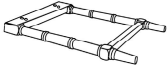
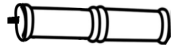
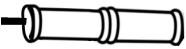
NOTICE



- * Please make sure that you have all parts indicated before you begin assembly of this item
- * This item should be assembled on a soft surface to prevent scratching the finish during assembly
- * This item may require periodic tightening
- * This item may require a pair of pliers to unscrew the screws to a suitable length during

Part List

PIECE	DESCRIPTION	PICTURE	QUANTITY
A	Desk Top		1X
B	Side panel		1X
C	Legs with short screws		4X
D	Legs with long screws		4X
E	Shelves		2X
F	Feet		4X
G	Allen Key Driver		1X
H	Allen Bot 8x1.41x35mm		4X
I	Flat Washers		4X

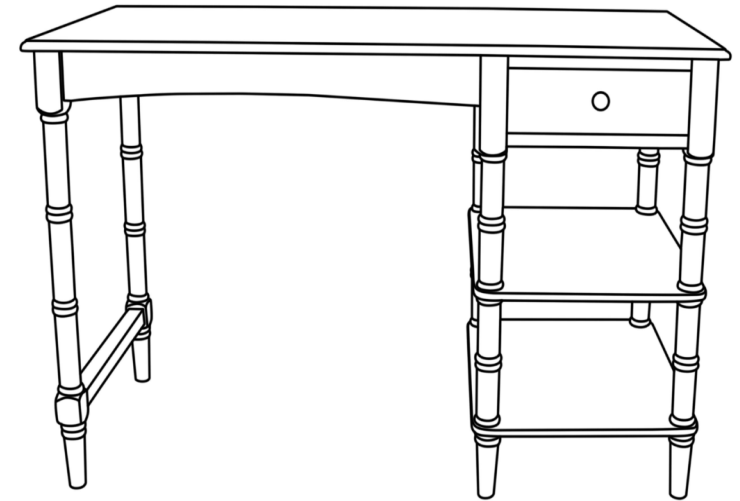
Product Dimensions: 45.5"W x 21.5"D x 29.5"H
Weight Capacity: 40LBS



 **WARNING** 

Warning: Do not stand on the Table
Warning: Do not over torque bolts.

PREPARATION

Before beginning assembly of product, make sure all parts are present. Compare parts with package contents list
If any part is missing or damaged, do not attempt to assemble the product.

Estimated Assembly Time: 5 minutes.

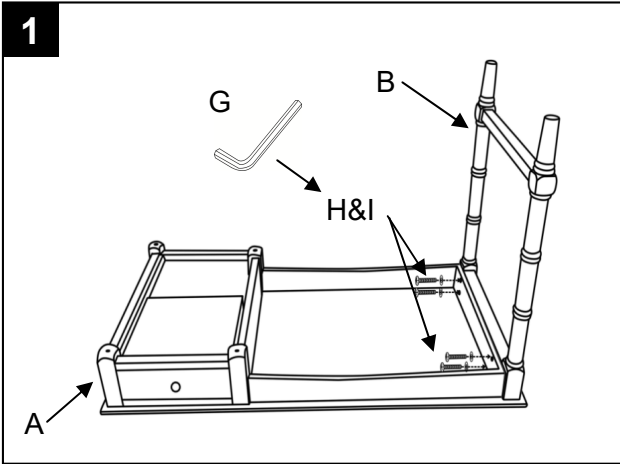

Step 1
Take all packaging off the desk.
Screw side panel B to desk top.
4pcs screws H&I and Allen key driver required.

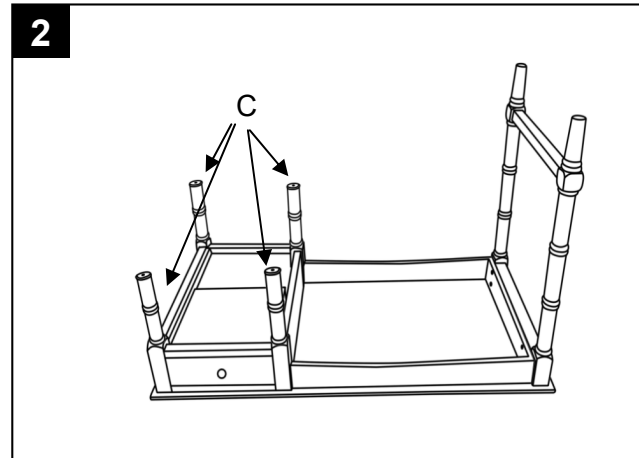

Step 2
Screw 4pcs leg with short screws C to desk top.

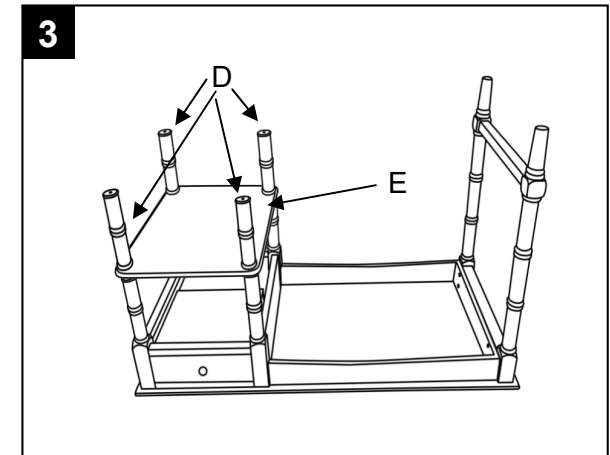

Step 3
Put 1pc shelf E over the legs with short screws C.
Screw 4pcs leg with long screws D to leg C

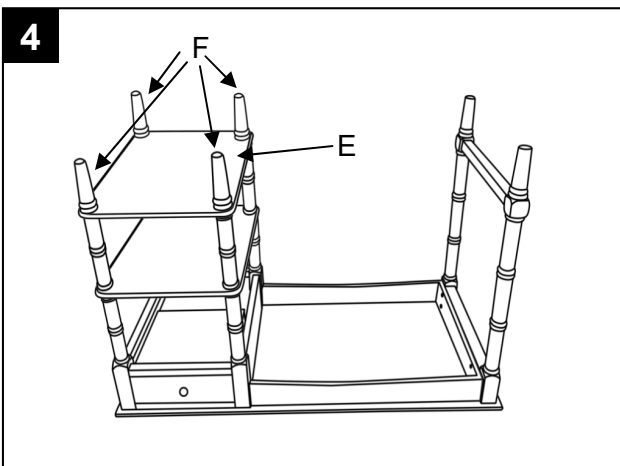

Step 4
Put the rest shelf E over the legs with long screws D.
Screw 4pcs feet F to leg D.

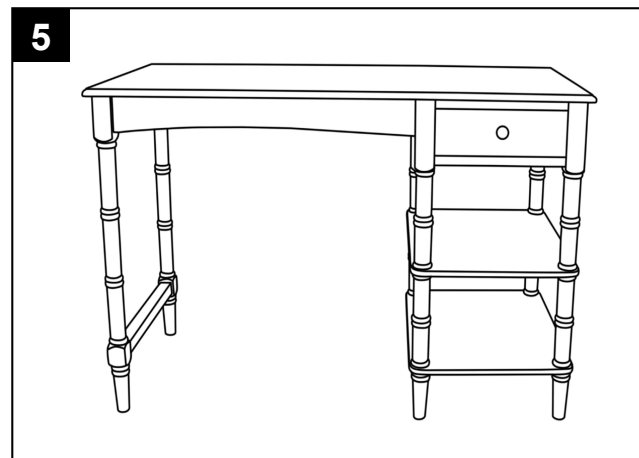

Step 5
Turn the desk up to the right side.
Assembling process done.