

ASSEMBLY INSTRUCTIONS

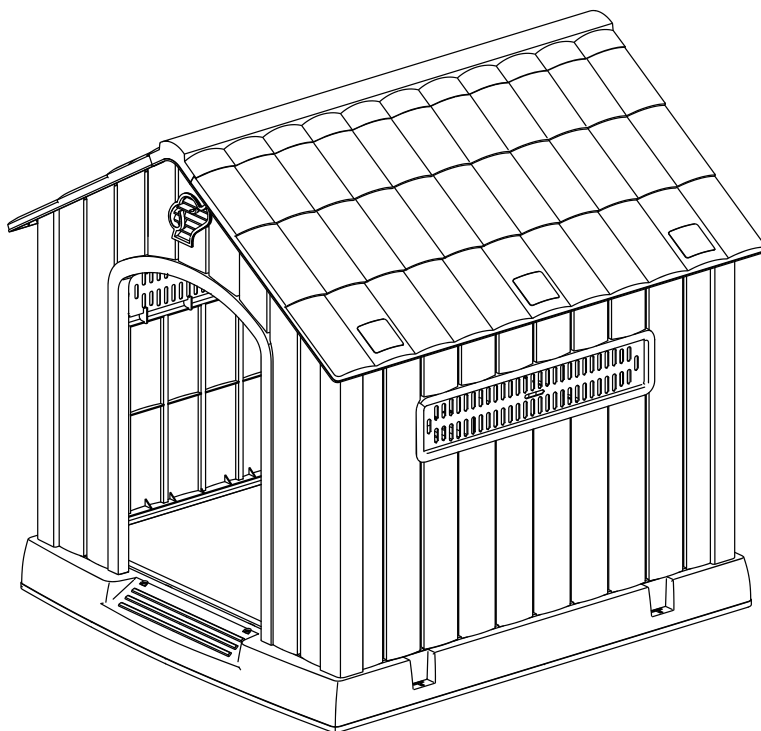

HOPE YOU HAVE A PERFECT SHOPPING EXPERIENCE!

Thank you for choosing our armless home office chair! Our products are designed to be both stylish and functional, with a focus on sustainability.

We use high-quality materials to ensure that our pieces are built last, so you can enjoy them for years. Whether you're looking for a cozy or stylish chair, we have something for everyone.

Our products are perfect for any home or office and we're confident that you'll love them as much as we do! If you any problems with the item, please feel free to contact our customer service team by email or text.



IMPORTANT SAFETY INSTRUCTIONS



Read these instructions carefully and retain them for future use.

When using the product, basic safety precautions always be followed to reduce the risk of injury, including the following:

- This product must be assembled by an adult.
- Keep children and pets away while assembling the product.
- Remove all the packing materials and review all components before assembly.
- Do not over-tighten the fasteners.
- To avoid scratching the floor, assemble the product on a soft surface, such as a carpet.
- Do not use this product if any parts are missing, damaged, or worn.
- Always use the product on a firm, level ground.
- Do not let the children climb on or play with the product.
- Do not stand on the seat.
- Keep all sharp objects away from the upholstery.
- Regularly examine the product for wear and tear. Stop using the product at the first sign of damage or if the parts detached.

Assembly

- If you need to refer to the installation video, you can scan the QR code on the first page.

PARTS LIST

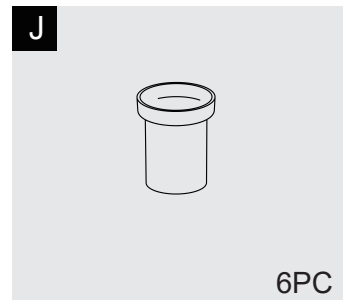
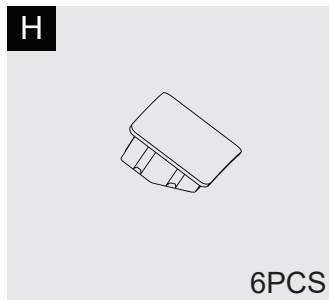
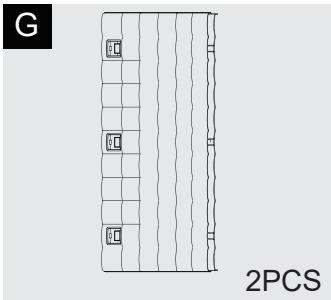
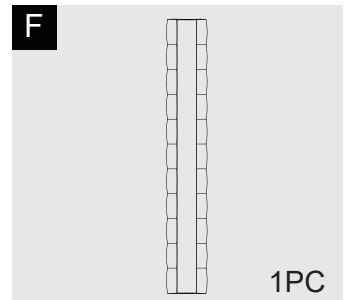
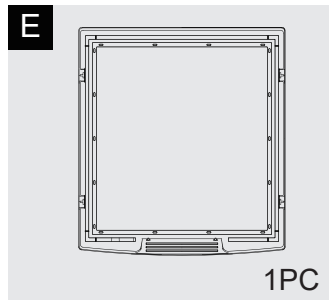
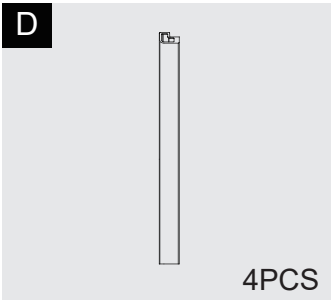
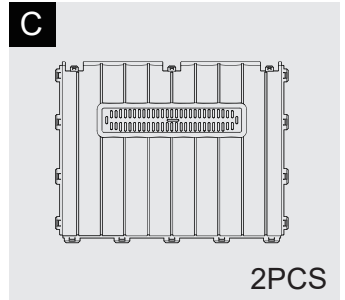
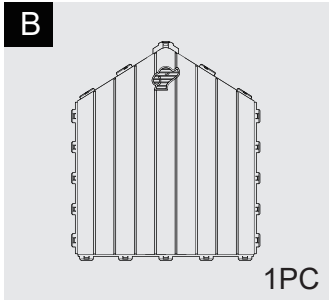
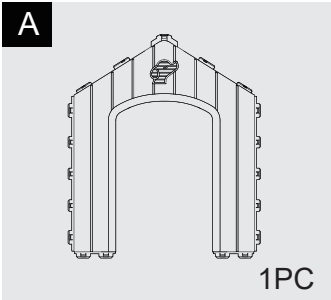

PARTS LIST

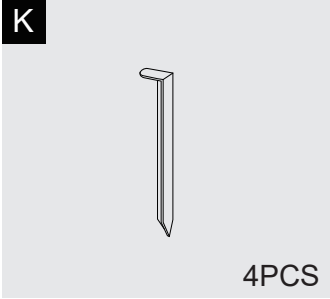

INSTALLATION STEPS

STEP 1

The door panels have matching buckles and slots. During installation, you can gently tap the panel to ensure the buckles and slots fit together securely.

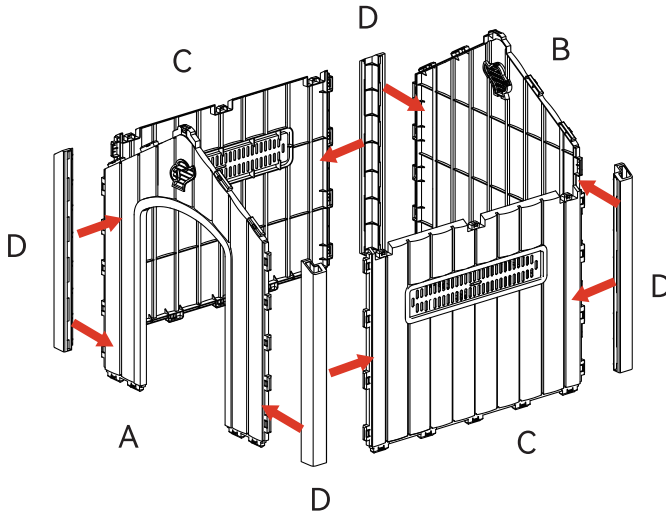

INSTALLATION STEPS

STEP 2

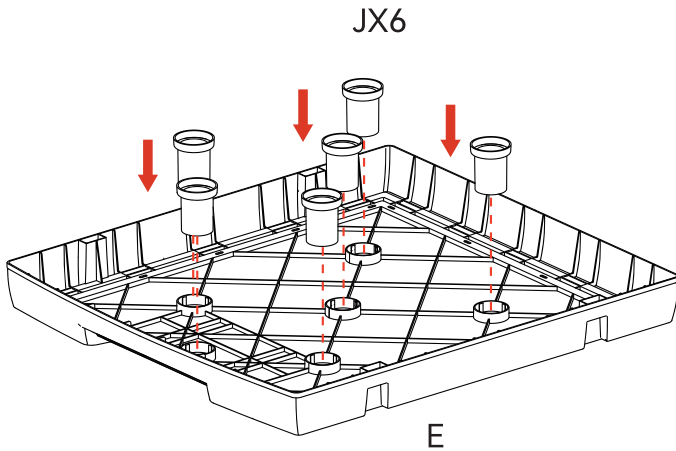

STEP 3

Start by aligning one side of the door panel with the base, then gently tap the top of the panel to engage the buckles with the corresponding slots on the base.

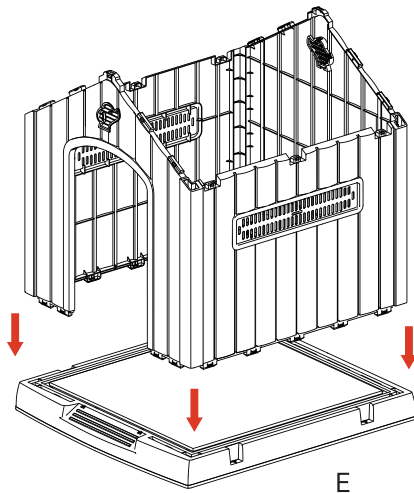

INSTALLATION STEPS

STEP 4

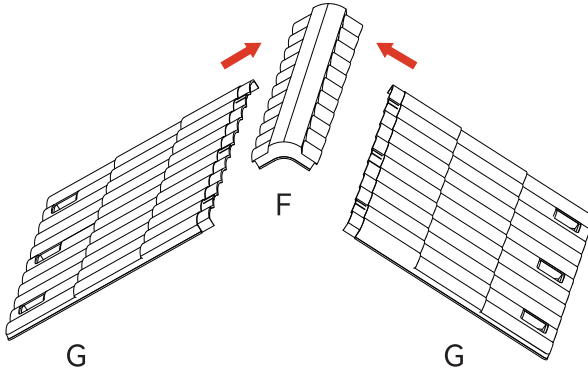

STEP 5

First align the buckles between the ridge and one side of the roof, then gently push the ridge to engage the buckles with their corresponding slots.

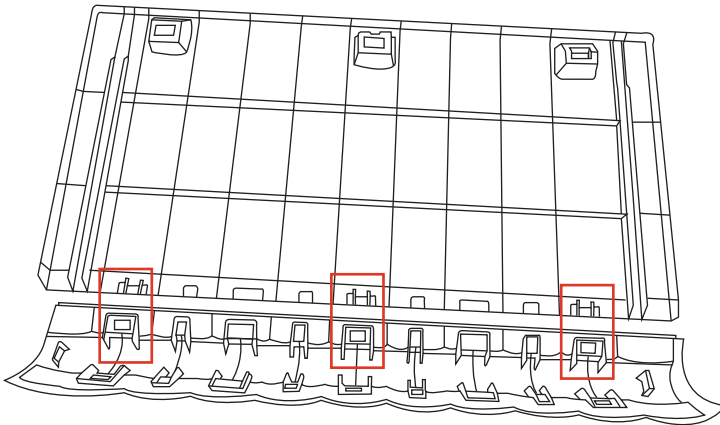

INSTALLATION STEPS

STEP 6

Lay the other roof section flat on the ground, then gently push the already installed half to align both sides. Finally, press firmly to engage the buckles.

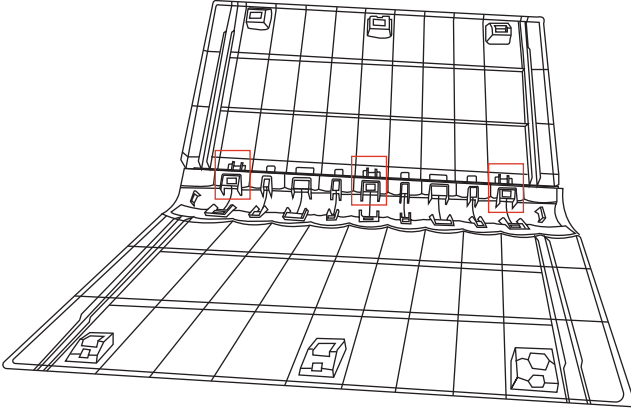

STEP 7

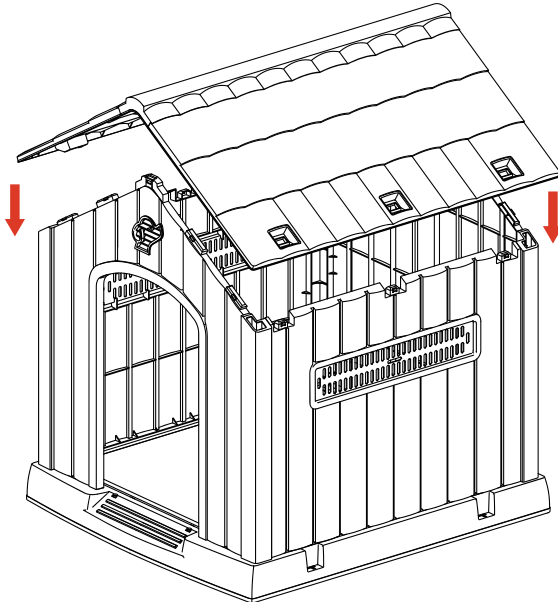

INSTALLATION STEPS

STEP 8

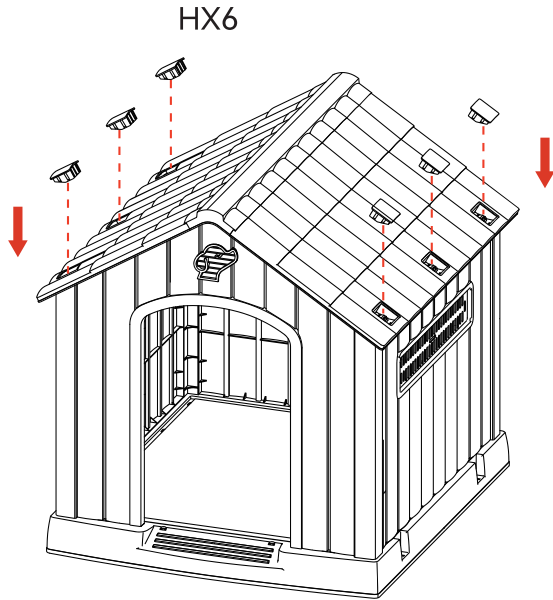

STEP 9

If placing the product on outdoor grass, install the ground stakes.

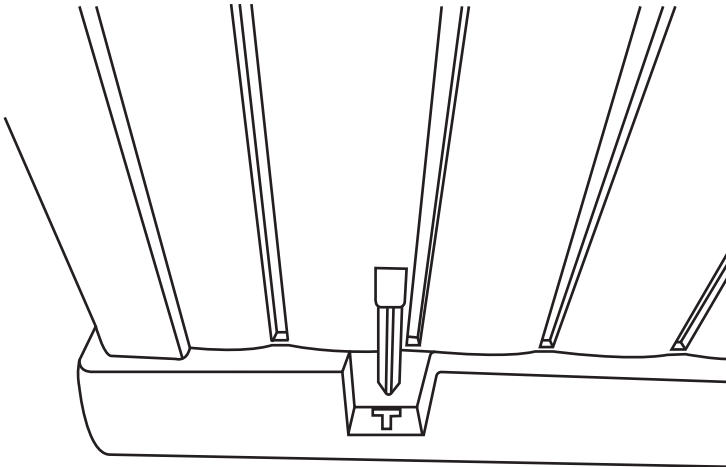

HELP CENTER

WE STAND BEHIND THE QUALITY OF OUR PRODUCT

1. If you have any other issues with your item(s), please feel free to contact us! We will always do our best to come up with a solution that you will be happy with.
2. Please get in touch with our customer service team before returning the item(s).
3. Please do not throw away the original box(es) if you have not finished assembling and confirmed no quality issues.

RETURN POLICY

Length of return period:

You can return the item(s) within 30 days of purchase.

In the meanwhile, everything you purchased from us comes with a one-year warranty.

Who is responsible for the return shipping fee:

We will cover the return shipping fees if:

1. Your item has a manufacturing defect in materials or workmanship. For example, material cracking or screw hole misalignment. We will send you a prepaid shipping label after you send us photos or videos of the defects.
2. Your item has been damaged in transit. For example, metal part is broken or product is damaged. We will send you a prepaid shipping label after you send us photos of the damage.
3. You receive the wrong box(es) due to a warehouse error, We will send you a prepaid shipping label after you send us photos of the item(s), shipping label(s) and words(SKU) on the outer box(es).

* However, we still hope to work with you for a better solution instead of a return. Please don't hesitate to contact our customer service team.

Customer will cover the return shipping fees if:

1. You don't like the item(s) after receiving the box(es).
2. You no longer need the item(s) but have received the box(es).
3. You buy the item(s) by mistake but have received the box(es).
4. Order/shipment cancellation failed, and you have received the box(es).

Return Request

In order to get a full refund as described in this return policy, all items must be:

1. In a brand new/unused condition. Please provide photos before and after packaging.
2. All accessories and parts must be firmly packed in all original packaging before returning. If your return does not meet these requirements, you may not receive a full refund.

When can I receive a refund?

After you return it using the prepaid shipping label we provided and inform us, the refund will be issued once the package(s) have been returned to our warehouse.

What can I do if the product is damaged after warranty?

We want you to be a happy customer. Please reach out to us via email or text, and we will work on a solution to ensure your satisfaction.