

# Assembly Instructions

**Caution : You must read this before you proceed**

## CHAIR

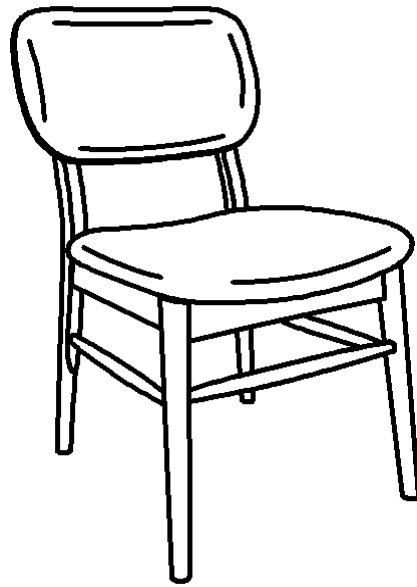



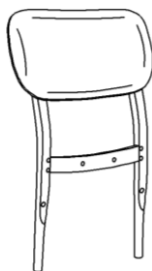
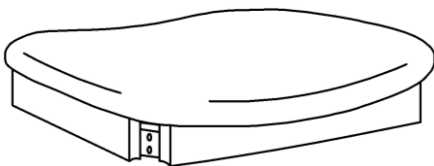

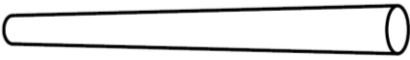
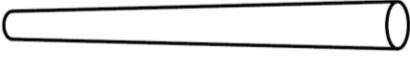
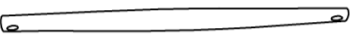
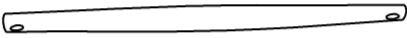

### Parts List

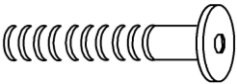
Label	Picture	Description	QTY
A		Back Rest	1
B		Chair Seat	1

C		Front Leg (L)	1
D		Front Leg (R)	1
E		Front Rail	1
F		Stretcher	2

## Hardware

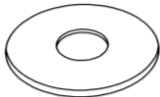
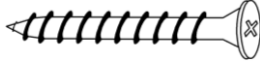
Label	Picture	Description	QTY
①		Bolt (M6 x 35mm)	3
②		Bolt (M6 x 60mm)	5
③		Bolt (M6 x 90mm)	5
④		Spring Washer (M6)	11

⑤		Washer (M6 x 19mm)	11
⑥		Screw (M4 x 35mm)	7
⑦		Allen Key	1
⑧		Screwdriver	not provide

## Assembly Preparation

Before Beginning Assembly:

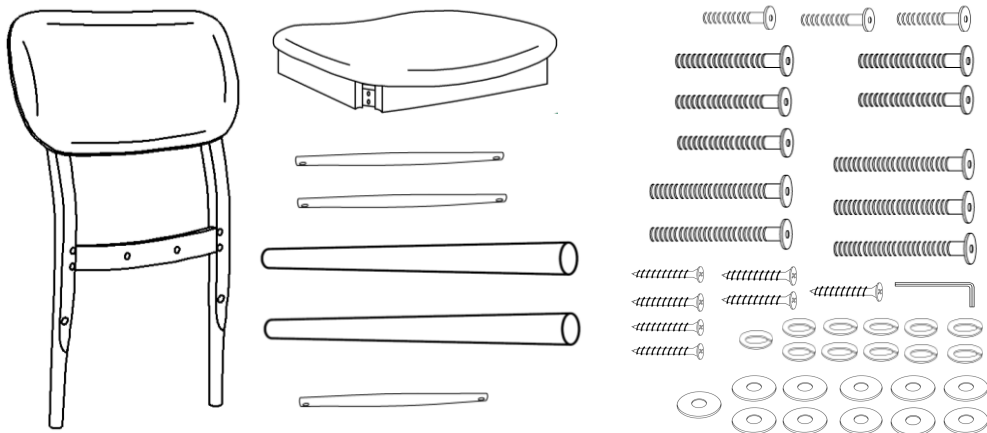

- Read instructions, cover to cover-



- Have 2 adults on hand for assembly-



- Do not assemble on flooring or carpet-



- Assemble on a clean non-marring surface (packing foam)-



- Save all packaging until finished-

## Assembly Steps

### Overview

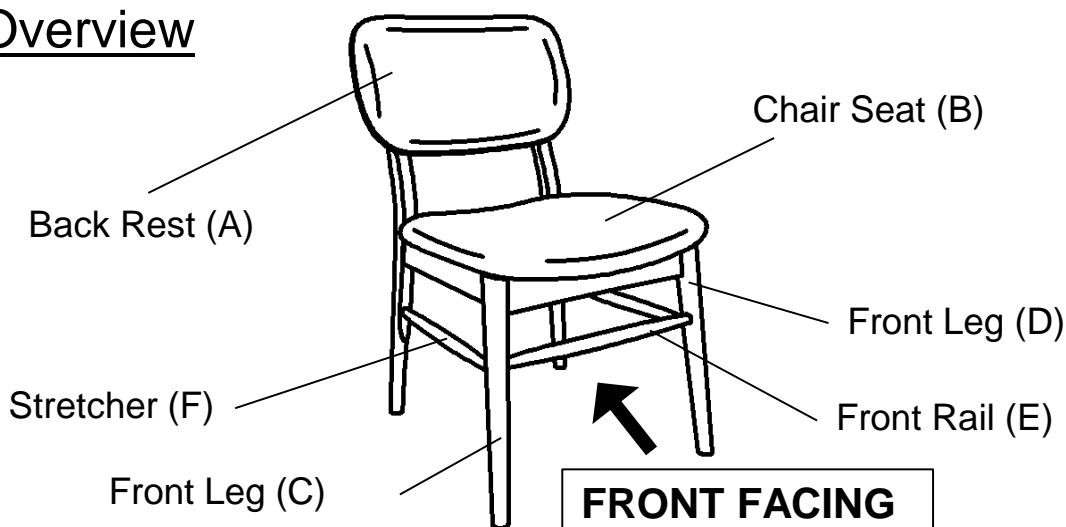

This Chair has multiple parts and may require up to 30 minutes to assemble. To give you an overview of the Chair parts, the above picture is to help you put the various parts into perspective. Please read through the instructions below to familiarise yourself with the parts and steps before assembly.

## Step 1

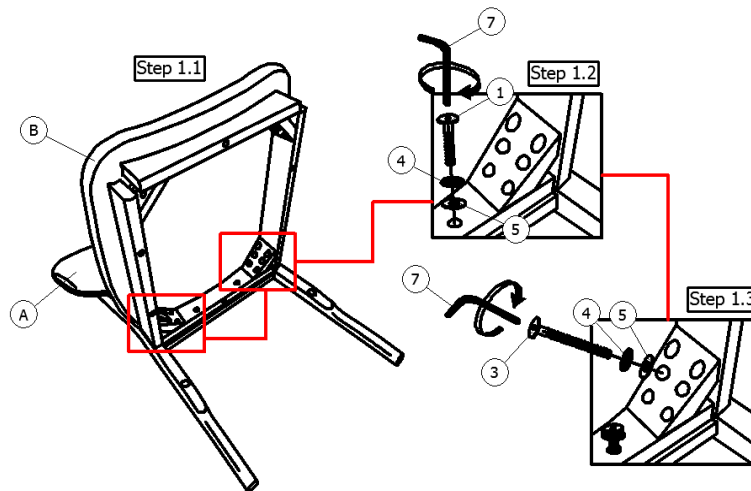

**1.1)** Align Chair Seat(B) to Back Rest(A).

**1.2)** Attach Chair Seat(B) to Back Rest(A) using Bolts(①), Spring Washers(④), and Washers(⑤) with Allen Key(⑦) as pictured.

**1.3)** Attach Chair Seat(B) to Back Rest(A) using Bolts(③), Spring Washers(④), and Washers(⑤) with Allen Key(⑦) as shown in the picture.

**Do not fully tighten the Bolts.**

## Step 2

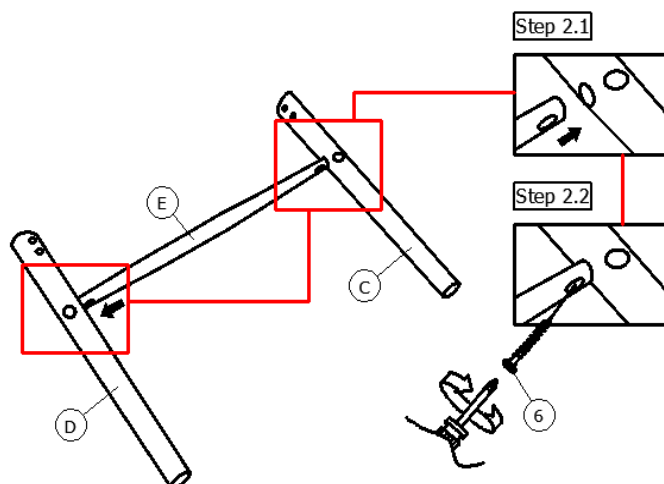

**2.1)** Insert the Front Rail(E) into the oval housings of Front Leg(C) and Front Leg(D) as shown above.

**2.2)** Attach Front Rail(E) to Front Leg(C) and Front Leg(D) using Screws(⑥) with Screwdriver(⑧).

**Do not fully tighten the Screws.**

### Step 3

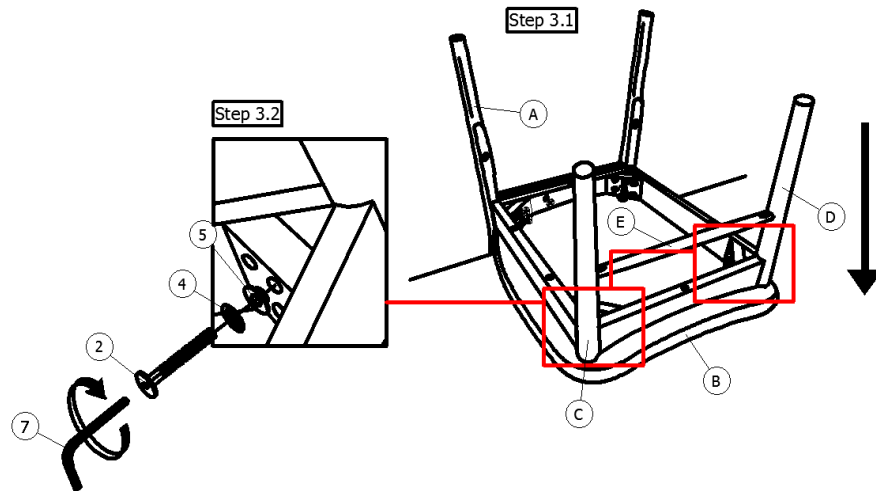

**3.1)** Place the Chair on the edge of a table, as shown. Then insert the Front Legs(C&D) into the bottom of the Chair Seat(B).

**3.2)** Attach using Bolts(②), Spring Washers(④), and Washers(⑤) with Allen Key(⑦).

**Do not fully tighten the Bolts.**

### Step 4

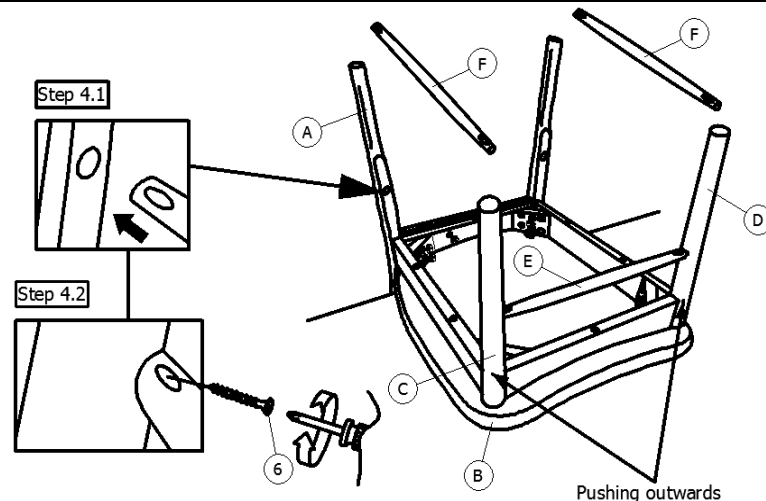

**4.1)** Place Stretchers(F) into housings between the hind legs of the Back Rest(A) and Front Leg(C) and Front Leg(D).

**4.2)** Attach Stretchers to Back Rest(A), Front Leg(C) and Front Leg(D) using Screws(⑥) with Screwdriver(⑧).

**Do not fully tighten the Screws.**

## Step 5

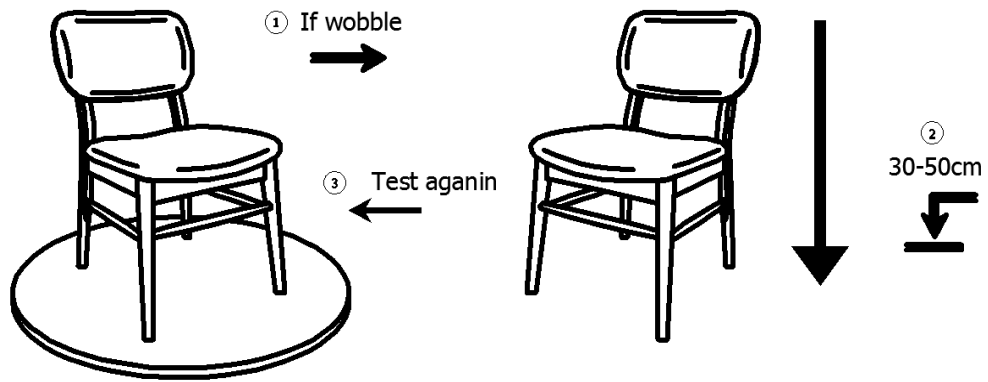

Place the Chair on a Level Surface to check for wobbles.

If there are wobbles, lift the Chair some 30cm to 50cm high from the ground, keep your feet and toes away from the drop zone, and drop the Chair vertically with all four legs, hitting the ground at the same time. The Drop Test will help to ensure that all Screws, Bolts and gaps reach full alignment. Test again for evenness on a Level Surface.

If no wobbles are found, proceed to tighten all Bolts and Screws.

**When tightening the Bolts and Screws, tighten sequentially. Do not tighten any Bolt or Screw fully and then move on towards the next one, this would cause the frame to warp.**

**If it still wobbles, loosen the Bolts and execute this same drop test.**

**If the Chair is not Stable it could lead to damage to the product.**

## Step 6

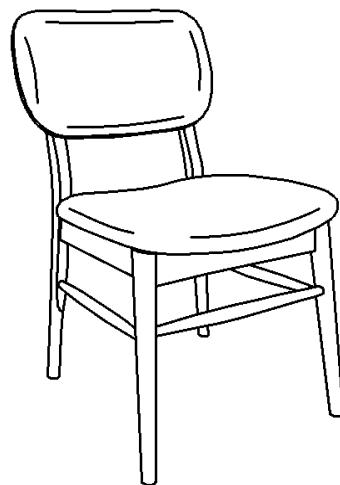

Your Chair is ready for use.

**This Chair can only be used on a flat, level surface.**

# Care & Maintenance

## Care & Maintenance

-   ● Do not put hot items directly on furniture surface
  -   ● Do not clean furniture with harsh cleansers or polish.
  -   ● Do not place furniture under direct sunlight.
  -   ● Do not place furniture near heating or cooling vents.
  -   ● Do not write on furniture without a padded barrier to protect the surface.
  -   ● Do not place furniture outside . For indoor use only .
  -   ● Not for commercial use. For residential use only .
  -   ● Stains may be removed with mild soap solution and damp cloth.
  -   ● Children should not climb or jump on the furniture.
- 
-   ● Dust and pick-up spills using a clean, non-colored, lint-free cloth .

### What is Proposition 65?

Proposition 65 is a California law that requires warning labels on products that may contain one of more than 800-plus chemicals or ingredients that the California Office of Environmental Health Hazard Assessment (OEHHA) has deemed to cause cancer or other reproductive toxicity. Chemicals and elements on this list include wood dust, brass, and other everyday substances, which can be found in very common household items, such as: lamps, tableware, jewelry, crystal glasses, electric cords, beauty products, automobiles, and furniture.

### Why Did I Find a Proposition 65 Warning on My Home Goods Product?

We include Proposition 65 warnings on all of our products because there is always a chance that one of the 800-plus common chemicals and ingredients listed under this law could potentially be on our furniture or packing materials. We risk large fines under this law, if we don't include this warning.

### Should I worry?

We realize you may be worried finding this warning on our products, but we want to reassure you that the hazardous exposure limits for any of these chemicals have never been found on furniture products that we've shipped to our customers. Additionally, this warning label is very common and can be found on almost every piece of furniture sold in the state of California.

### Just How Common Are Proposition 65 Warnings?

Proposition 65 warnings have become so common in California that it is hard to take a trip to a local bank, grocery store, or restaurant without finding at least one warning. In fact, even the Disney Land Resort has a Proposition 65 warning:

