











Assembly Instruction

①*1pc		A*4+1EXT	 M6*30MM
②*1pc		B*2+1EXT	 M6*20MM
③*1pc		C*6+1EXT	 M6*16MM
④*1pc		D*2	
⑤*1pc		G*1	 M4

STEP1

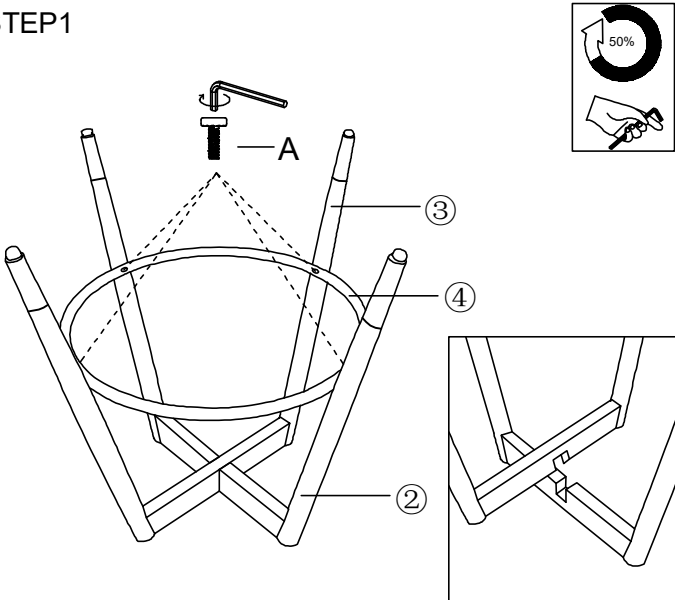

50%

STEP2

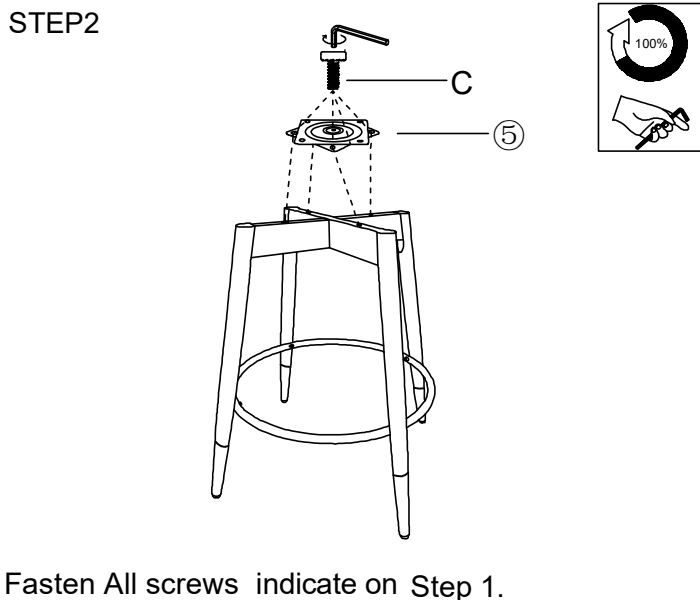

100%

Fasten All screws indicate on Step 1.

STEP3

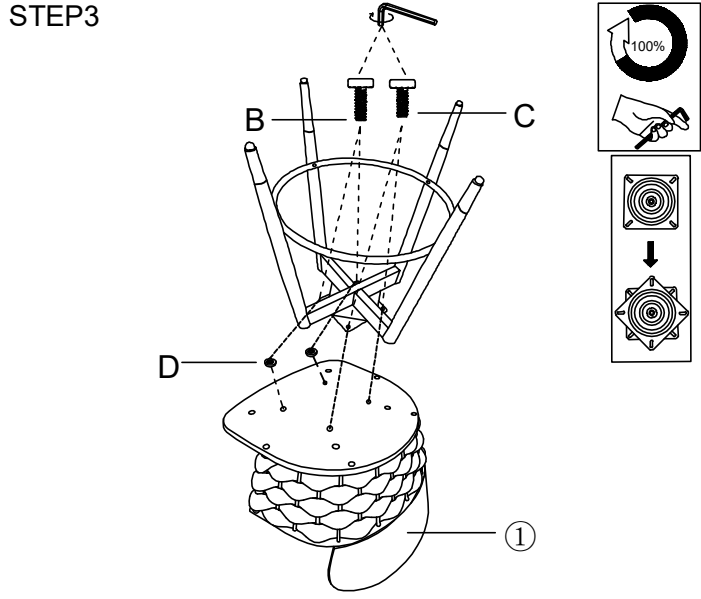

100%

STEP4

