

ASSEMBLY INSTRUCTIONS

CHAIR

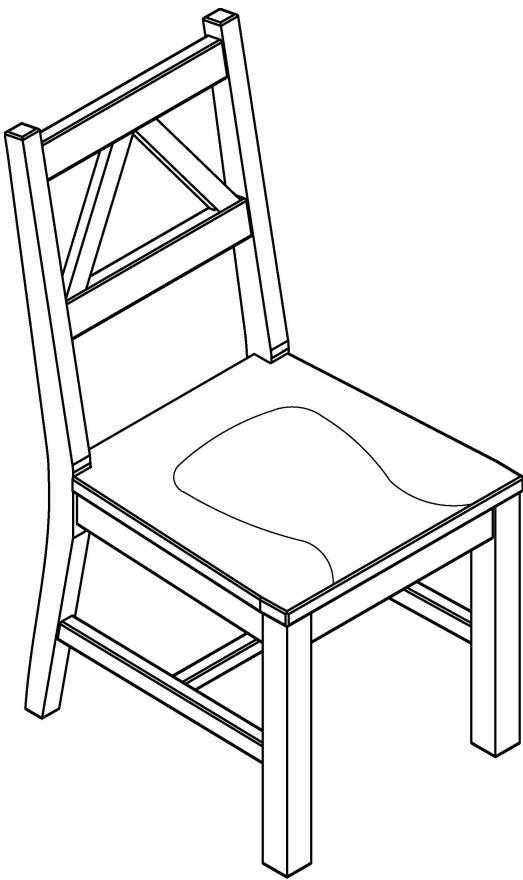

Front view

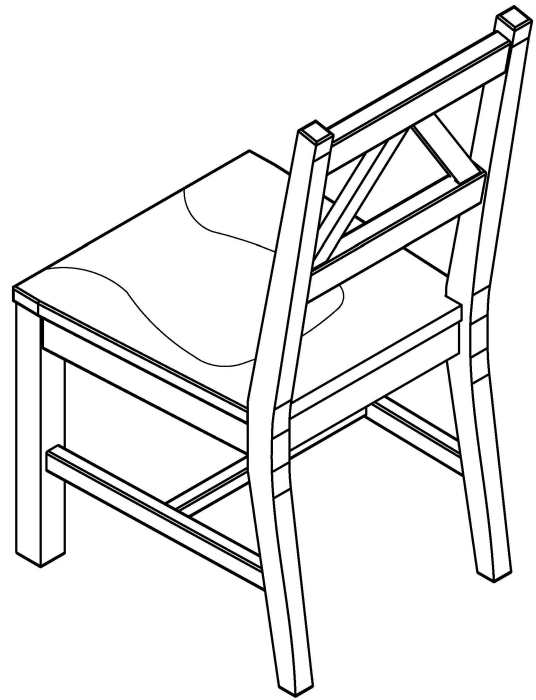

Back view

PARTS IDENTIFICATION



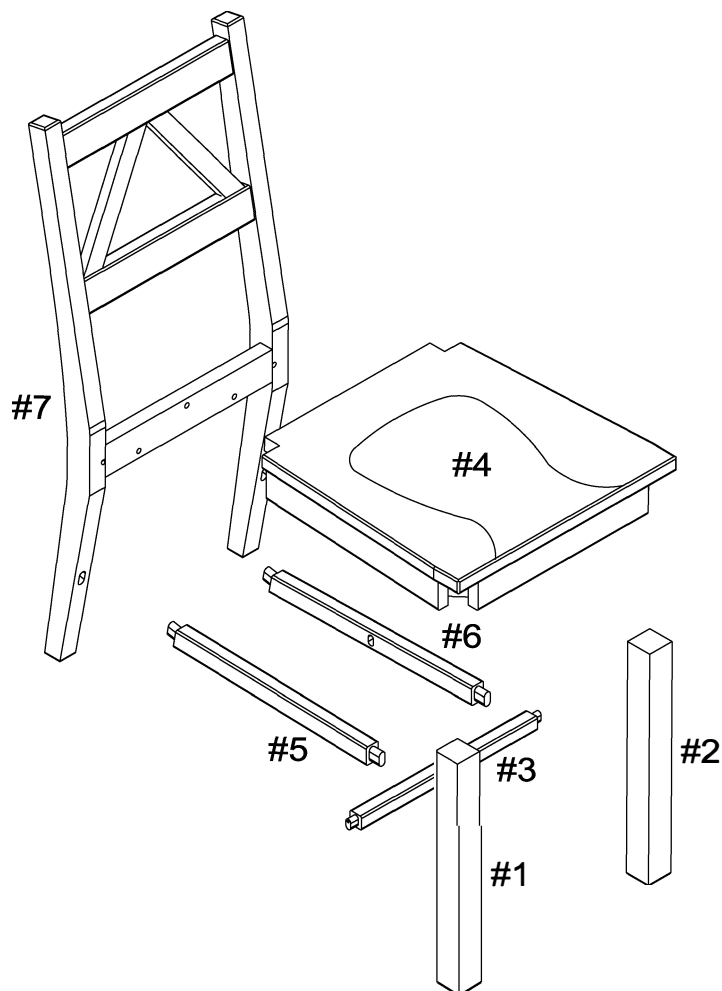

ITEM	DESCRIPTION	QTY
#1	LEFT LEG	01
#2	RIGHT LEG	01
#3	FRONT RAIL	01
#4	SEAT	01
#5	LEFT RAIL	01
#6	RIGHT RAIL	01
#7	BACKREST	01

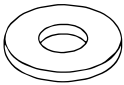

For ease of identification all parts are labeled to correspond to the Step number in which the part is used.

HARDWARE IDENTIFICATION

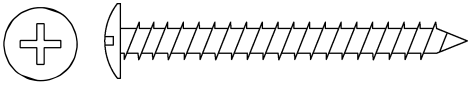
Please line up the hardware with the correct full size image to make sure you are installing the hardware correctly.

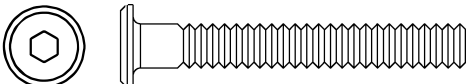
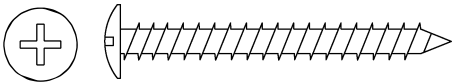
ITEM	PICTURE	DESCRIPTION	QTY
A	 (Ø6x60mm) Not to Scale	LARGE BOLT	06
B	 (Ø20mm) Not to Scale	FLAT WASHER	09
C	 (Ø10mm) Not to Scale	SPRING WASHER	09
D	 (Ø6x40mm) Full Size	SMALL BOLT	03
E	 (Ø4x45mm) Full Size	LONG SCREW	04
F	 Not to Scale	ALLEN KEY	01
G	 (Ø6x70mm) Not to Scale	BOLT	02
H	 (Ø4x40mm) Full Size	SCREW	02

Tools required



STEP 1.

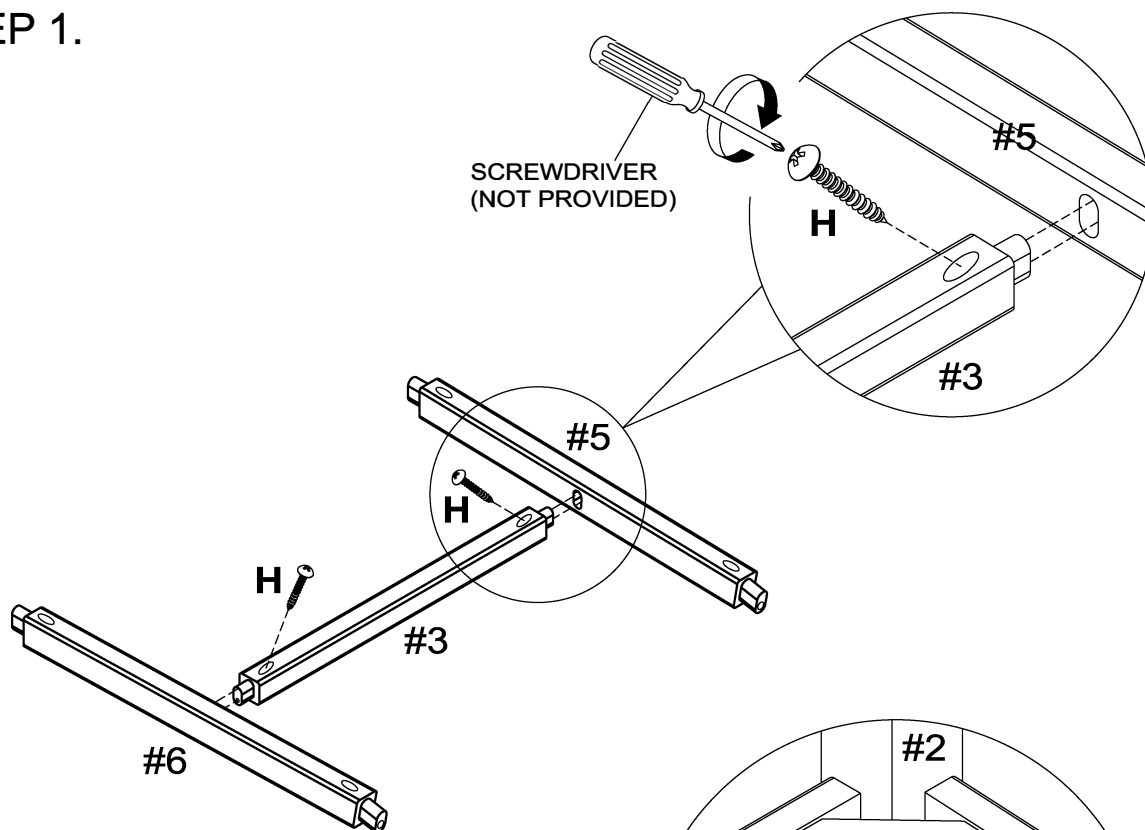

STEP 2.

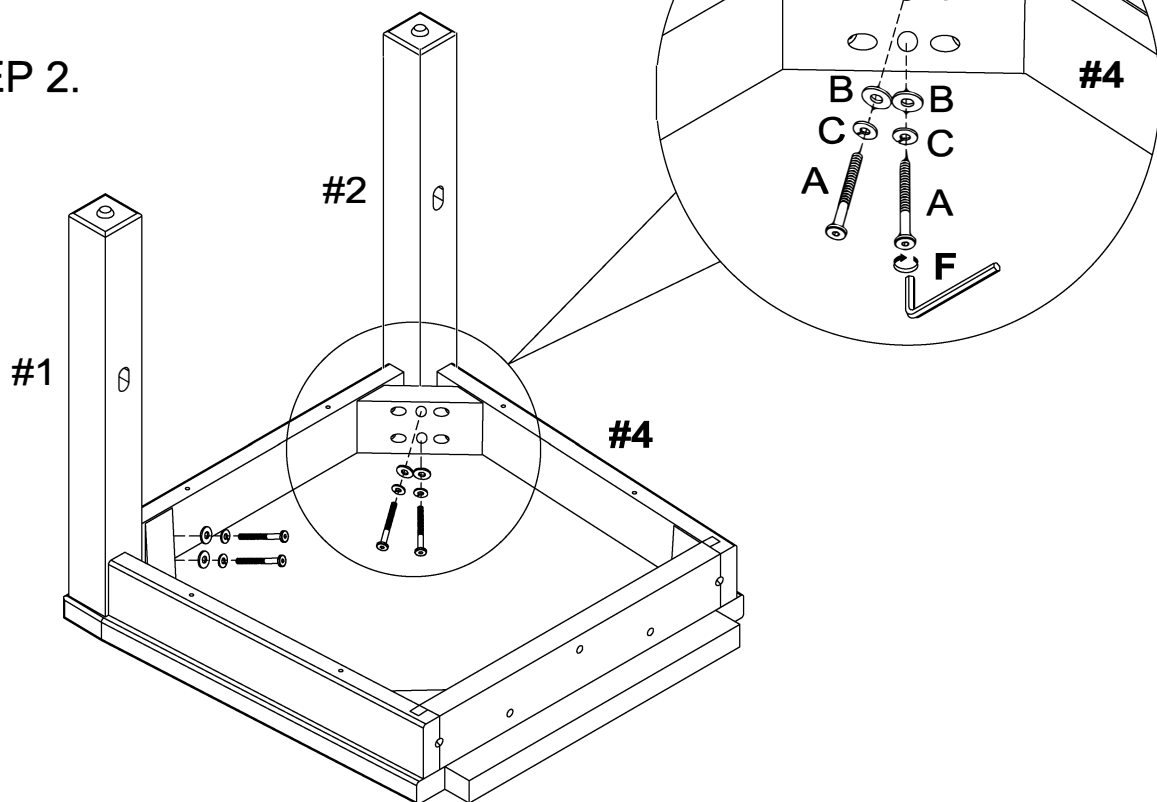

IMPORTANT:

1. DO NOT TIGHTEN BOLTS COMPLETELY UNTIL ALL BOLTS ARE COMPLETELY LINED UP AND INSERTED INTO HOLES / NUTS.
2. DO NOT OVER TIGHTEN SCREWS AND BOLTS TO AVOID STRIPPING.

STEP 3.

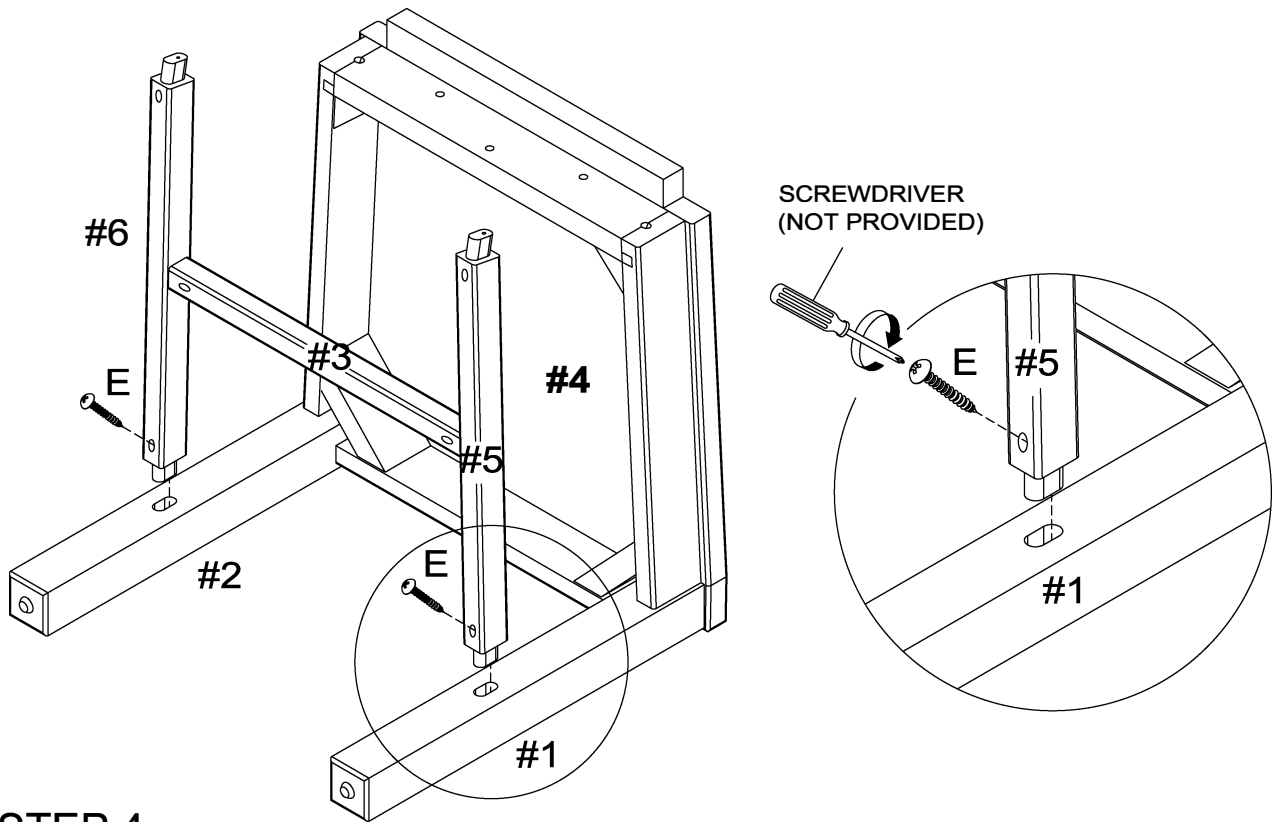

STEP 4.

